

Bulletin 154



New Mexico Bureau of Mines & Mineral Resources

A DIVISION OF  
NEW MEXICO INSTITUTE OF MINING & TECHNOLOGY

# **Proceedings of the 31st Forum on the Geology of Industrial Minerals— The Borderland Forum**

Edited by George S. Austin, Gretchen K. Hoffman, James M. Barker,  
Jiri Zidek, and Nancy Gilson

*New Mexico Bureau of Mines and Mineral Resources, Socorro, New Mexico 87801*

NEW MEXICO INSTITUTE OF MINING & TECHNOLOGY  
Daniel H. Lopez, *President*

NEW MEXICO BUREAU OF MINES & MINERAL RESOURCES  
Charles E. Chapin, *Director and State Geologist*

**BOARD OF REGENTS**

Ex Officio

Gary Johnson, *Governor of New Mexico*  
Alan Morgan, *Superintendent of Public Instruction*

Appointed

Steve Torres, *President, 1991-1997, Albuquerque*  
Delilah A. Vega, *Student Member, Secretary/Treasurer, 1995-1997, Socorro*  
Diane D. Denish, *1992-1997, Albuquerque*  
J. Michael Kelly, *1992-1997, Roswell*  
Charles Zimmerly, *1991-1997, Socorro*

**BUREAU STAFF**

BARRY ALLRED, *Hydrogeologist*  
ORIN J. ANDERSON, *Senior Geologist*  
RUBEN ARCHULETA, *Metallurgical Lab. Tech.*  
GEORGE S. AUSTIN, *Senior Industrial Minerals Geologist*  
ALBERT BACA, *Maintenance Carpenter II*  
JAMES M. BARKER, *Assistant Director,  
Senior Industrial Minerals Geologist,  
Supervisor, Cartography Section*  
PAUL W. BAUER, *Field Economic Geologist*  
LYNN A. BRANDVOLD, *Senior Chemist*  
RON BROADHEAD, *Assistant Director,  
Senior Petroleum Geologist,  
Head, Petroleum Section*  
RITA CASE, *Administrative Secretary (Alb. Office)*  
STEVEN M. CATHER, *Field Economic Geologist*  
RICHARD CHAMBERLIN, *Field Economic Geologist*  
RICHARD R. CHAVEZ, *Assistant Head, Petroleum Section*  
SEAN CONNELL, *Field Geologist*  
RUBEN A. CRESPIN, *Garage Supervisor*  
NELIA DUNBAR, *Geochemist*  
RICHARD ESSER, *Lab Technician*  
ROBERT W. EVLETH, *Senior Mining Engineer*

NANCY S. GILSON, *Assistant Editor*  
KATHRYN G. GLESENER, *Manager, Cartography Section*  
DEBBIE GOERING, *Staff Secretary*  
IBRAHIM GUNDILER, *Senior Metallurgist*  
WILLIAM C. HANEBERG, *Assistant Director,  
Engineering Geologist*  
BRUCE HART, *Petroleum Geologist*  
JOHN W. HAWLEY, *Senior Environmental Geologist,  
Manager, Albuquerque Office*  
LYNN HEIZLER, *Assistant Curator*  
MAU HEIZLER, *Geochronologist*  
LYNNE HEMENWAY, *Computer Pub./Graphics Spec.*  
CAROL A. HJELLMING, *Associate Editor*  
GRETCHEN K. HOFFMAN, *Senior Coal Geologist*  
PEGGY JOHNSON, *Hydrogeologist*  
GLEN JONES, *Manager, Digital Cartography Laboratory*  
PHILIP KYLE, *Geochemist/Petrologist*  
ANN LANNING, *Executive Secretary*  
ANNABELLE LOPEZ, *Petroleum Records Clerk*  
THERESA L. LOPEZ, *Receptionist/Staff Secretary*  
DAVID W. LOVE, *Senior Environmental Geologist*

JANE A. CALVERT LOVE, *Editor*  
VIRGIL LUETH, *Mineralogist/Economic Geologist*  
FANG LUO, *Petroleum Engineer*  
MARK MANSELL, *GIS Technician*  
DAVID McCRAW, *Cartographer II*  
WILLIAM MCINTOSH, *Volcanologist/Geochronologist*  
CHRISTOPHER G. MCKIM, *X-ray Facility Manager*  
VIRGINIA T. MCLEMORE, *Senior Economic Geologist*  
NORMA J. MEEKS, *Director of Publications Office*  
LISA PETERS, *Lab Technician*  
BARBARA R. POPP, *Biotechnologist*  
MARSHALL A. REITER, *Senior Geophysicist*  
SANDRA SWARTZ, *Chemist, QA/QC Manager*  
TERRY TELLES, *Technical Secretary*  
REBECCA J. TITUS, *Senior Cartographer*  
JUDY M. VAIZA, *Business Sera. Coordinator*  
Manuel J. VASQUEZ, *Mechanic II*  
SUSAN J. WELCH, *Manager, Geologic Extension Service*  
MICHAEL WHITWORTH, *Chemical Hydrogeologist*  
MAUREEN WILKS, *Bibliographer*  
Jiri ZIDEK, *Chief Editor/Senior Geologist*

ROBERT A. BIEBERMAN, *Emeritus Sr. Petroleum Geologist*  
FRANK E. KOTLOWSKI, *Emeritus Director/State Geologist*  
JACQUES R. RENAULT, *Emeritus Senior Geologist*

SAMUEL THOMPSON III, *Emeritus Sr. Petroleum Geologist*  
ROBERT H. WEBER, *Emeritus Senior Geologist*

**Research Associates**

WILLIAM L. CHENOWETH, *Grand Junction, CO*  
CHARLES A. FERGUSON, *Univ. Alberta, CAN*  
JOHN W. GEISSMAN, *UNM*  
LELAND H. GILE, *Las Cruces*  
CAROL A. HILL, *Albuquerque*  
BOB JULYAN, *Albuquerque*  
SHARI A. KELLEY, *NMT (adjunct faculty)*  
WILLIAM E. KING, *NMSU*

BARRY S. KUES, *UNM*  
MICHAEL J. KUNK, *USGS*  
TIMOTHY F. LAWTON, *NMSU*  
DAVID V. LEMONE, *UTEP*  
SPENCER G. LUCAS, *NMMNH&S*  
GREG H. MACK, *NMSU*  
NANCY J. McMILLAN, *NMSU*  
HOWARD B. NICKELSON, *Carlsbad*

GLENN R. OSBURN, *Washington Univ.*  
ALLAN R. SANFORD, *NMT*  
JOHN H. SCHILLING, *Reno, NV*  
WILLIAM R. SEAGER, *NMSU*  
EDWARD W. SMITH, *Tesque*  
John F. Sutter, *USGS*  
RICHARD H. TEDFORD, *Amer. Mus. Nat. Hist.*  
TOMMY B. THOMPSON, *CSU*

**Graduate Students**

ROBERT APPELT  
GINA DEROSA  
DAVID ENNIS  
MICHAEL HEYNEKAMP

NATALIE LATYSH  
His Lm  
DAVID J. SIVILS  
JOE STROUD

JINGLAN WANG  
JASON WISE

Plus about 30 undergraduate assistants

*Original Printing*

Published by Authority of State of New Mexico, NMSA 1953 Sec. 63-1-4  
Printed by University of New Mexico Printing Services, July 1996

Available from New Mexico Bureau of Mines & Mineral Resources, Socorro, NM 87801  
Published as public domain, therefore reproducible without permission. Source credit requested.



## CONTENTS

	PAGE
<b>PREFACE</b> .....	iii
<b>ACKNOWLEDGMENTS</b> .....	vi
<b>KEYNOTE ARTICLE</b>	
Industrial minerals and rocks of the tri-state border region—West Texas, southern New Mexico, and northern Chihuahua .....	K. F. Clark 7
<b>MEXICO</b>	
Overview of celestite deposits of south-central Coahuila, Mexico—Geology and exploitation.....	A. Rodriguez Garza and W. N. McAnulty, Jr. 27
Economic exploitation of the Cretaceous Lagrimas Formation for production of portland cement, Ciudad Juarez, Chihuahua, Mexico .....	G. Garcia 33
<b>TEXAS</b>	
Brucite deposit in Marble Canyon, Culberson County, Texas .....	T. E. Newman and G. K. Hoffman 37
Texas—Industrial minerals, imports, and exports .....	P. C. Sweet 43
<b>NEW MEXICO</b>	
Overview of the Carlsbad potash district, New Mexico .....	J. M. Barker and G. S. Austin 49
Modern New Mexico adobe—A response to some environmental concerns G. S. Austin and M. R. Goolsby .....	63
Travertine in New Mexico—Commercial deposits and otherwise J. M. Barker, G. S. Austin, and D. J. Sivils .....	75
Limestones of New Mexico and adjoining areas suitable for sulfur removal in coal-fired power plants* ... ..	F. E. Kottowski and A. K. Armstrong 93
Geology and chemistry of humate deposits in the southern San Juan Basin, New Mexico* .....	G. K. Hoffman, J. Verploegh, and J. M. Barker 105
Economic geology of the St. Cloud Mining Company (Cuchillo Negro) clinoptilolite deposit, Sierra County, New Mexico .....	J. L. White, W. X. Chavez, Jr., and J. M. Barker 113
Industrial specifications of the Wind Mountain nepheline-syenite deposit, Cornudas Mountains, Otero County, New Mexico* .....	V. T. McLemore and J. R. Guilinger 121
Geology, mineral resources, and marketing of the Wind Mountain nepheline-syenite porphyry, Cornudas Mountains, New Mexico and Texas .....	V. T. McLemore, V. W. Lueth, J. R. Guilinger, and T. C. Pease 127
Garnet resource potential in southern New Mexico .....	V. W. Lueth 137
Recovery of garnet from Hanover mine tailings, Grant County, New Mexico, USA .....	U. Cetin, I. F. Walder, V. W. Lueth, and I. H. Gundiler 147
Franklin Industrial Minerals—Mica plant operations in New Mexico* .....	G. L. Nelson 159
Economic geology of perlite in New Mexico* ... J. M. Barker, R. M. Chamberlin, G. S. Austin, and D. A. Jenkins .....	165
Genetic aspects of commercial perlite deposits in New Mexico .....	R. M. Chamberlin and J. M. Barker 171
<b>OTHER STATES</b>	
Natural clinker—The red dog of aggregates in the Southwest .....	G. K. Hoffman 187
Advances in the understanding of the industrial mineral resources of the state of Georgia .....	M. D. Cocker and B. J. O'Connor 197
Background stream-sediment geochemistry and hydrochemistry of a major river basin in Georgia—Use in industrial-mineral-resource and environmental studies .....	M. D. Cocker 207
Heavy minerals in fine-grained waste materials from sand and gravel plants of Indiana .....	N. R. Shaffer 215
Geology of resources for crushed-stone aggregate in Arkansas .....	S. W. Kline 223
<b>INTERNATIONAL</b>	
Industrial minerals south of the Mexican border .....	P. W. Harben 231
Hydrothermal and residual kaolin deposits of Chile .....	A. Gajardo 245
Economic geology of Cretaceous deposits in Nova Scotia .....	K. A. MacLeod 253
The Mount Gelai hectorite deposit, Arusha District, Tanzania, East Africa .....	T. H. Eyde 257
<b>GENERAL TOPICS</b>	
Cat litter—A growing market for industrial minerals .....	G. S. Austin and C. Mojtabai 267
Domestic pumice and garment wet-processing .....	J. M. Hoffer 275
Brick tunnel-kiln thermal-energy inputs .....	G. F. Cudahy and G. S. Austin 283
Value added—Refractory dolomite, a case study .....	D. A. Hopkins 291
Industrial minerals operations—Tying ISO 9000 to geology and reserve management .....	D. A. Holmes 293
Spreading the word about geology through teacher workshops .....	C. M. Simard 301

\*Article presented at 1994 Annual Meeting of SME in Albuquerque, N.M.

**APPENDIX 1: Presentations as abstract only**

Geology and industrial minerals of northeastern Mexico .....	<i>A. E. Alatorre, A. Colin, and K. Santini</i>	305
Industrial-mineral ore analysis using laser-induced breakdown spectroscopy .....	<i>J. Blacic, D. Petit, D. Cremers, W. Laughlin, and L. Fluk</i>	307
Application of real-time field mapping systems to enhance data gathering and productivity in the mining industry .....	<i>G. S. Dymesich and B. A. Hillman</i>	309
The 32nd Annual Forum on the Geology of Industrial Minerals—Laramie, Wyoming, May 1996 .....	<i>R. E. Harris</i>	311
Quantitative XRD—The minerals make the difference .....	<i>R. E. Hughes and D. M. Moore</i>	313
The Amarillo Texas silica deposit, Texas .....	<i>L. W. Krumrey, Jr.</i>	314
A comparison of geology and industrial uses of pumice deposits in the Jemez Mountains, New Mexico ..	<i>M. A. Linden and D. N. Tafoya</i>	316
Alerces: An economic development opportunity—Exploitation of high-quality industrial minerals .....	<i>R. Martinez, J. Perez, and M. Martinez</i>	318
Source of diamonds in Ghana, West Africa .....	<i>D. I. Norman, S. McKittrick, and H. Appiah</i>	319
Some observations on the origin of bentonites .....	<i>I. E. Odom</i>	321
The industrial minerals of the Sultanate of Oman .....	<i>R. F. Riordan and J. F. Pasquet</i>	322
High-calcium-limestone occurrences and industry in Utah .....	<i>B. T. Tripp</i>	323

<b>APPENDIX 2: List of registrants (professional)</b> .....		325
---	--	-----

### **Acknowledgments**

The effort for the Forum and the publication of this proceedings was fully supported by the New Mexico Bureau of Mines and Mineral Resources and by Director Dr. Charles E. Chapin. We are grateful that the Bureau appreciates industrial minerals and their importance in the Borderland region. Additional financial support from ECC International, St. Cloud Mining Company, and New Mexico Travertine is gratefully acknowledged. Special thanks are due to the team of Tina T. Ortiz and Drs. William X. Chavez and Geraldo W. Gross for their efforts on the Spanish-language program with abstracts made available at the meeting and to Dr. Gross for his Spanish translations of abstracts for this proceedings.

# Industrial minerals and rocks of the tri-state border region— West Texas, southern New Mexico, and northern Chihuahua

Kenneth F. Clark

*Department of Geological Sciences, University of Texas at El Paso, El Paso, Texas 79968, USA*

**Abstract**—Industrial minerals and rocks in the tri-state border region are located in a variety of geologic environments and vary in age from Precambrian through Recent. Their impact on combined population centers comprising approximately two million people in the cities of El Paso, Texas; Ciudad Juarez and Chihuahua, Chihuahua; and nearby Las Cruces, New Mexico, has been of utmost importance, as thirty one commodities are used. These locales were first populated by Indian settlements, and subsequently during the last four centuries by Spanish pioneers and by Mexican and United States citizens.

Rhyolite and granite from Proterozoic lithologic units of the Franklin Mountains that bisect El Paso, together with Paleozoic and Mesozoic limestones, are widely used in wall construction that characterizes the city. Other construction materials include brick manufacture on both sides of the international line, derived from Cretaceous clay beds surrounding the Cerro de Cristo Rey laccolithic intrusion located in the Paso del Norte. High-quality tile is produced in Chihuahua City, the clay being derived from a nearby shale of Permo-Pennsylvanian age. Of increasing commercial importance is the burgeoning cement industry in the environs of Ciudad Juarez, whose market stretches throughout the region and beyond. Other construction materials include aggregate derived from valley-fill deposits of the Rio Grande and adjacent basins, used in concrete and block manufacture. Historically and persisting for several centuries, adobe preceded fired-brick production. Adobe buildings are still common throughout the region, in contrast to the soft, Tertiary volcanic tuff (cantera) that was used in Spanish colonial buildings, best noted

- locally in Chihuahua City but less so in the Ciudad Juarez cathedral.

The chemical minerals of the Permian Delaware Basin are produced on a scale of national importance. Included here is potash of the Carlsbad district of southeastern New Mexico and Frasch sulfur production in adjacent Culberson County, west Texas. Halite, gypsum, and barite have also been produced from this basin.

Pegmatite minerals, fluor spar, and rhyolite, the latter for road metal use, have been produced from magmatic-hydrothermal deposits in west Texas in previous years. Scoria continues to be produced in the Las Cruces area. The potential for nepheline syenite production from the Cornudas Mountains in southernmost New Mexico has recently been investigated.

Architectural stone is produced from an underground mine in the thermally metamorphosed aureole of Permian age limestone and dolomite at Marble Canyon, west Texas. In the Van Horn area regionally metamorphosed Proterozoic units supply ceramic-grade talc. Finally, two eolian basin-fill deposits are or soon may be excluded from commercial exploitation. In southern New Mexico White Sands National Monument occupies a part of a basin that contains gypsum dune sands, and in northern Chihuahua the quartz dune sands of Samalayuca have been modestly exploited for metallurgical purposes.

## Minerales y rocas industriales de la region fronteriza triestatal del oeste de Texas, sur de Nuevo Mexico y norte de Chihuahua

**Resumen**—Los minerales y rocas industriales en la región fronteriza triestatal se encuentran en una diversidad de ambientes geológicos y varían en edad desde el Precámbrico hasta el Reciente. Su impacto sobre los centros combinados de población que comprenden más de dos millones de personas en las ciudades de El Paso (Texas); Juarez y Chihuahua (Chihuahua); y la cercana Las Cruces (Nuevo Mexico), ha sido de la más grande importancia, ya que se aprovechan 31 tipos de recursos minerales. Estas localidades fueron primeramente pobladas por indígenas y posteriormente, durante los últimos cuatro siglos, por los colonizadores españoles y por ciudadanos de Mexico y de los Estados Unidos.

La riolita y el granito de las unidades litológicas del Proterozoico de las Montañas Franklin que separan a la ciudad de El Paso en dos partes, junto con calizas del Paleozoico y Mesozoico, son ampliamente usados en la construcción de muros que caracterizan a la ciudad. Otro material de construcción es el ladrillo que se fabrica en ambos lados de la frontera internacional. La materia prima viene de capas de arcilla del Cretácico que rodean el lacolito Cerro de Cristo Rey ubicado en el Paso del Norte. En la ciudad de Chihuahua se produce mosaico de alta calidad de una lutita cercana de edad Pensilvánico-Permiana. De creciente importancia comercial es la floreciente industria del cemento en los alrededores de Ciudad Juarez, cuyo mercado se extiende por toda

la región y más allá. Otros materiales de construcción incluyen agregados derivados de los depósitos de relleno de los valles del Río Grande y cuencas adyacentes, utilizados en la fabricación de concreto y bloque. Históricamente y persistiendo por varios siglos, el adobe precedió a la producción del ladrillo cocido. Las edificaciones de adobe son todavía muy comunes en toda la región, en contraste con la toba volcánica suave del Terciario (*antera*) que fue utilizada en los edificios coloniales españoles, con los mejores ejemplos en la Ciudad de Chihuahua y un poco menos en la catedral de Ciudad Juárez.

La producción de minerales químicos de la cuenca Delaware del Pérmico es de importancia nacional. Incluidos aquí está la potasa del Distrito de Carlsbad del sureste de Nuevo México y el azufre Frasch en el vecino condado de Culberson, oeste de Texas. Halita, yeso y barita también son productos de esta cuenca.

Minerales pegmatíticos, fluorita y riolita, esta última para use como balasto en vías férreas, han sido producidos de depósitos magmático-hidrotermales en el oeste de Texas en años anteriores. Escoria continua produciéndose en el área de Las Cruces; y se ha investigado recientemente el potencial para producir sienita nefelínica de las Montañas Cornudas en el extremo sur de Nuevo México.

Se produce piedra ornamental de una mina sub terranea en la aureola metamorfizada térmicamente en caliza y dolomita del Pérmico en *Marble Canyon*, en el oeste de Texas. En el área de Van Horn unidades del Proterozoico metamorfizadas regionalmente aportan talco de grado cerámico. Finalmente, dos depósitos de relleno de cuenca ya están o pronto serán excluidos de la explotación comercial. El Monumento Nacional *White Sands* en el sur de Nuevo México ocupa parte de una cuenca que contiene dunas de arena de yeso y en el norte de Chihuahua las dunas de arena de cuarzo de Samalayuca han sido explotadas moderadamente para propósitos industriales.

### Introduction

Industrial minerals and rocks in the tri-state border region have been a major factor in sustaining population growth and activity for over four centuries. Previously there had been more limited use of stone, clay, and gemstones by the indigenous peoples. Since the time of the first Spanish pioneers in 1542 and subsequent settlements, there has been a steady increase in demand and use for locally derived building stone and other materials to sustain the activities of local inhabitants whose population has steadily grown over the years. Presently the principal population centers of El Paso, Texas; Ciudad Juárez, Chihuahua; and Las Cruces, New Mexico (Fig. 1), have a combined population of over two million including farms and ranches within the Río Grande valley. Smaller towns of Silver City, Lordsburg, Deming, and Alamogordo, New Mexico; Villa Ahumada and Ascension, Chihuahua; and Fort Hancock, Sierra Blanca and Van Horn, Texas; are also within the region under consideration (Figs. 1 and 2). The southern part of this region includes the capital of Chihuahua state, a city of approximately 600,000 population (Fig. 3). Smaller towns include Cuauhtemoc, Delicias, Meoqui, Nuevo Casas Grandes, Ojinaga, and Villa Aldama. With population growth and industrialization, use of nonmetallic commodities has grown and also diversified, the latter largely due to technological developments in the United States, leading to uses that were hitherto unknown.

While the demands of the local population have spurred exploitation of resources, potash and sulfur are now produced and exported from the border region because of their chemical or physical characteristics. These two commodities have become nationally important to both the United States and Mexico. In a few instances other commodities are imported to yield the desired product through manufacturing processes, most notably fluorspar for the production of hydrofluoric acid in Ciudad Juárez.

The great diversity of geologic environments in the border region spans Precambrian through Recent time. Thus, in time and space, commodities have their origin not only in sedimentary and igneous processes, but also in their metamorphic equivalents. These commodities

reflect the various geologic processes that have taken place as a geologic interval of approximately more than 1.327 Ga evolved.

Traditionally, the El Paso-Ciudad Juárez area has been a transportation hub and is destined to retain this characteristic as the North American Free Trade Agreement (NAFTA) develops. The principal north-south route is from Chihuahua City northward to the international line to Las Cruces and beyond. The principal east-west route is through to El Paso, Las Cruces, Lordsburg, and beyond. These routes are characterized by four-lane highways and railroads. Chihuahua City also has a significant east-west route from Presidio, Texas, to the west coast. The principal cities are also serviced by national and international airlines.

Finally, the area covered in this paper is partly dictated by the six field excursions that were organized by the writer and held in conjunction with the 31st Forum on the Geology of Industrial Minerals. These excursions were designed to cover the major industrial mineral deposits of the region, although necessary time constraints prohibited visits to most of the smaller and less well-known deposits in the region. Three excursions were held in west Texas and southern New Mexico and three in Chihuahua. For geologic details and references to corresponding literature, only a small part of which will be summarized here, the reader should refer to Clark (1995 a-e), and Clark and Holguin (1995).

### Physiographic and tectonic provinces

Figures 1, 2, and 3 show the major physiographic and tectonic features of the border region and include the Datil-Mogollon section of the Colorado Plateau province in the far northwest part of the region. This predominantly Tertiary volcanic rock area is bounded to the south and east by part of the Basin and Range province. The major population centers of Ciudad Juárez, El Paso, and Las Cruces are located in the north-trending Río Grande rift.

The Basin and Range province continues southward into adjacent parts of northern Chihuahua, locally referred to as Cuencas y Sierras (Fig. 3). The increasing lower and wider basins near the Río Grande (Bravo) are known as the Bolson Section (Sección de Bolsones).

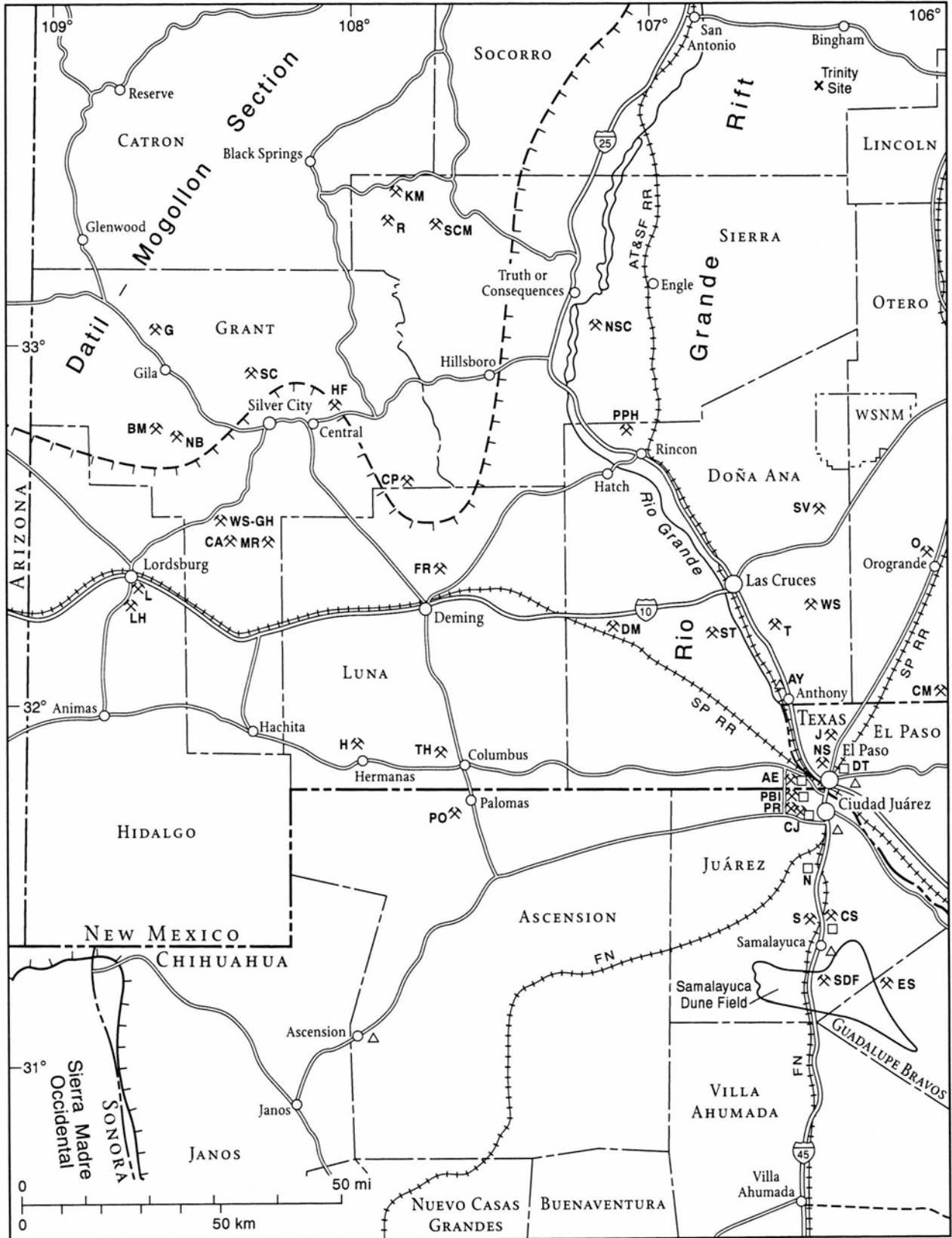

FIGURE 1—Sketch map of the northwestern part of the tri-state border region, showing principal towns, physiographic and tectonic features. Also shown are industrial mineral and rock locations. See Table 1 for abbreviations. ✕ mine, □ plant.

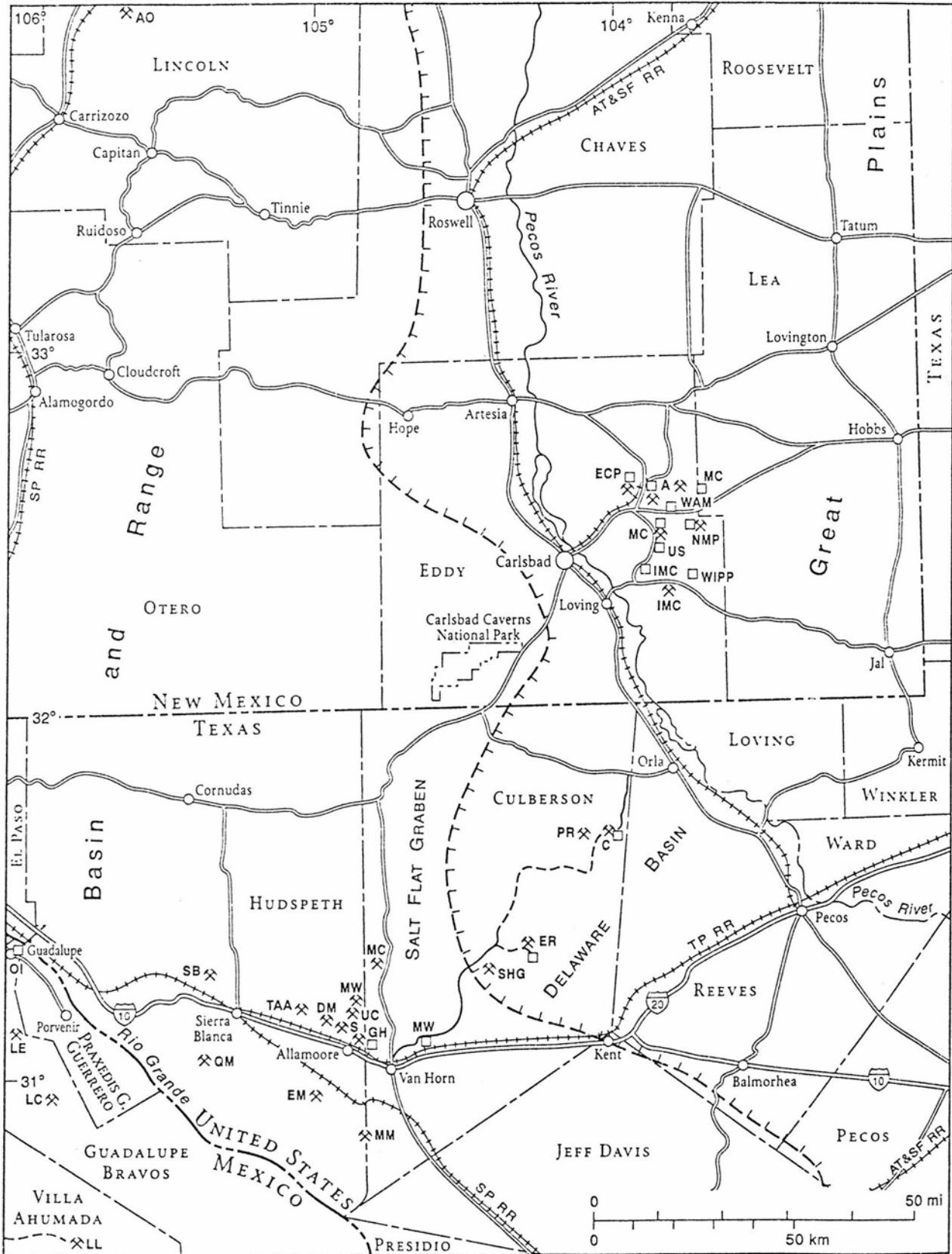

FIGURE 2—Sketch map of the northeastern part of the tri-state border region, showing principal towns, physiographic and tectonic features. Also shown are industrial mineral and rock locations. See Table 1 for abbreviations. ✕ mine, □ plant.

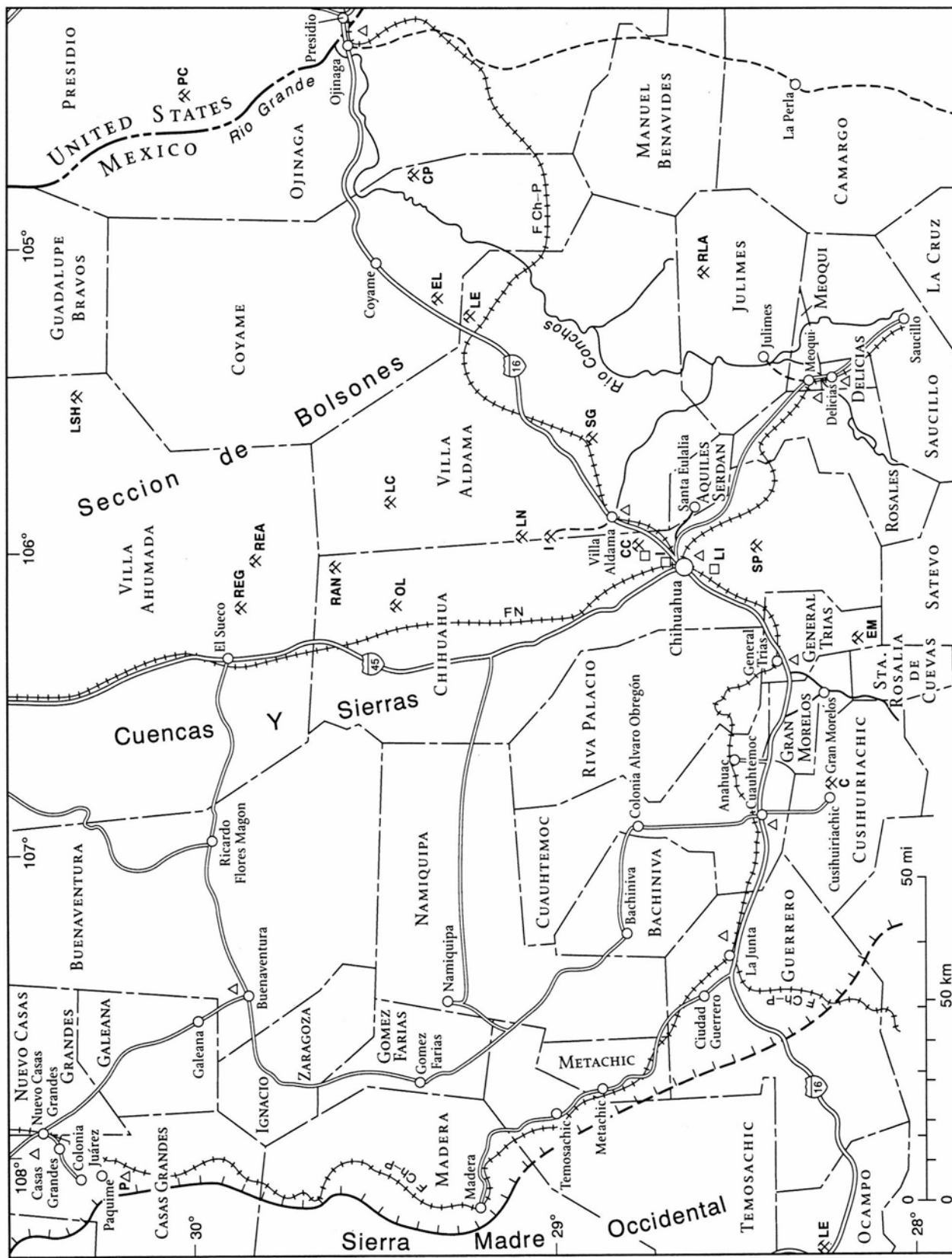

FIGURE 3—Sketch map of the southern part of the tri-state border region, showing principal towns, physiographic and tectonic features. Also shown are industrial mineral and rock locations. See Table 1 for abbreviations. ♂ mine, □ plant.



Southeastern New Mexico is part of the Great Plains province (Fig. 2), that extends into the easternmost part of west (Trans-Pecos) Texas, and includes the Delaware Basin, where a variety of valuable mineral resources are exploited. Immediately to the west the Basin and Range province extends southeastward towards Big Bend National Park area and flanks the Rio Grande on its north-east side. It is conspicuously represented by the Sall Basin graben in which the community of Van Horn, Texas, is located (Fig. 2).

### Lithologic constitution

Although a brief commentary on the regional lithologies is made here, the reader is referred to a variety of state-wide publications for greater detail. Among these references are the Geologic Map of New Mexico (scale 1:500,000) by Dane and Bachman (1965), Geologic Atlas of Texas, Van Horn—El Paso sheet (scale 1:250,000), reprinted in 1975 by the Texas Bureau of Economic Geology (V. E. Barnes, Project Director), and Plano Geologic Minero, Chihuahua, (scale 1:500,000), printed in 1985 by Sociedad Geologica Mexicana. The latest geologic map of Chihuahua has been released by Consejo de Recursos Minerales (Cardenas Vargas, 1994, scale 1:500,000). As indicated previously, the Border Region is represented by all the time-stratigraphic systems, varying in age from Proterozoic through Recent (Fig. 4).

### Precambrian

In New Mexico Precambrian rocks are extensively exposed in the Burro Mountains of southwestern New Mexico and southwest of Silver City and in the Caballo Mountains east of Truth and Consequences. Precambrian rocks are also found in the Florida Mountains and in the eastern flank of the San Andres Mountains. Pegmatites were sporadically exploited in Precambrian rocks of the Burro Mountains. In Texas various units are well exposed in the Franklin Mountains of El Paso and in the Van Horn area and provide aggregate. Mica production has been recorded at the Mica mine in the Van Horn Mountains (King and Flawn, 1953). The ceramic-grade talc deposits of the Allamoore district formed in the unit of the same name by dynamic metamorphism along the Streeruwitz thrust in late Proterozoic time (King and Flawn, 1953; Soegaard and Callahan, 1994).

### Paleozoic

The succeeding Paleozoic strata (Fig. 4) are dominated by carbonate units with lesser amounts of shale and other clastic rocks. In El Paso and Ciudad Juarez they support the cement/concrete industry. Elsewhere these strata are well exposed in the Big Hatchet, Caballo, and San Andres uplifts in the western part of the region and cover or underlie much of the surface between Alamogordo and Carlsbad in southeastern New Mexico. Permian sedimentary rocks host Frasch sulfur mining in Culberson County, Texas (Fig. 2), and the evaporitic facies in the Carlsbad area supports the local potash industry. Further south and 40 km north-northeast of Chihuahua City, the weakly metamorphosed, clastic Rara Formation of Permo-Pennsylvanian age provides the principle material of the local tile industry.

### Mesozoic

The Mesozoic lithologies are variable in their lithologic characteristics, and several facies provide raw mineral materials for the nonmetallic mining and fabrication in

dustries. Triassic and early Jurassic strata are absent in several areas of the border region because of non-deposition or erosion (Fig. 4), but Cretaceous strata are widespread. Chihuahua-trough deposition and accumulation of carbonate strata with subsequent uplift during the Laramide orogeny and/or Basin-and-Range block-faulting events are common in northern Chihuahua. Early Cretaceous limestone is used at two plants in the Ciudad Juarez area (Fig. 1) that are currently supplying the bulk of the cement production in the border region (editors' note: see Garcia, this volume). Cement is also produced from Lower Cretaceous limestone in Chihuahua City (Fig. 3), and gypsum and argillaceous components are located in Cretaceous strata. One plant each in Ciudad Juarez and El Paso produce brick from Cretaceous shales exposed on the eastern flank of Cerro de Cristo Rey formed by laccolithic intrusion of andesite in mid-Tertiary time (editors' note: see Cudahy and Austin, this volume).

### Cenozoic

The Tertiary is well represented by volcanic flows in the Datil—Mogollon section of the Colorado Plateau province (Fig. 1) and intermediate and siliceous varieties commonly cap ranges in southwestern New Mexico and northwestern Chihuahua. Soft, ash-flow tuffs of Oligocene age are the traditional building stones for colonial buildings in Chihuahua City, less so in Ciudad Juarez and smaller communities in Mexico. Zeolites are recovered from the Tertiary tuff of Little Mineral Creek at the southern end of the Winston graben in southern New Mexico (editors' note: see White, Barker, and Chavez, this volume).

Previously, there has been fluor spar production in the Van Horn area of west Texas and at several localities in southern New Mexico and northern Chihuahua (Fig. 1). Nepheline syenite intrusions of the Cornudas Mountains, dated at 35-32 Ma (Barker, 1977) have potential for ceramic flux and/or glass production (editors' note: see McLemore and Guilinger, this volume; McLemore, Lueth, Guilinger, and Pease, this volume). The contact metamorphic aureole developed around a Tertiary syeno-monzonite intrusion in contact with the dolomitic Hueco Limestone, has produced brucite-rich architectural stone at Marble Canyon in the Van Horn area (Fig. 2), located in the western flank of the Salt Flat graben (editors' note: see Newman and Hoffman, this volume). In southern New Mexico, scoria production comes from Late Tertiary—Quaternary cinder cones in the Las Cruces area.

The geologic column is completed by including the traditional use of alluvium in river valleys and other surficial environments for adobe brick production. Pediment and, or terrace gravel, possibly equivalent of the Camp Rice Formation (Strain, 1966), have been exploited for aggregate use, in Ciudad Juarez, El Paso, and elsewhere. Cinder block is produced at the Bermudez quarry and plant in western Ciudad Juarez, from sand and gravel deposits that overlie Fort Hancock clay lake beds (Clark and Melendez, 1989). Lastly, the eolian deposits of the White Sands National monument are preserved as a recreational area and hopefully, the Samalayuca, Chihuahua, quartz-dune field may be preserved in the same manner.

### Construction materials

#### Natural stone and aggregate

In El Paso there has been widespread use of the Red Bluff granite and to a lesser extent the Thunderbird rhyolite, both of Proterozoic age and part of the crystalline

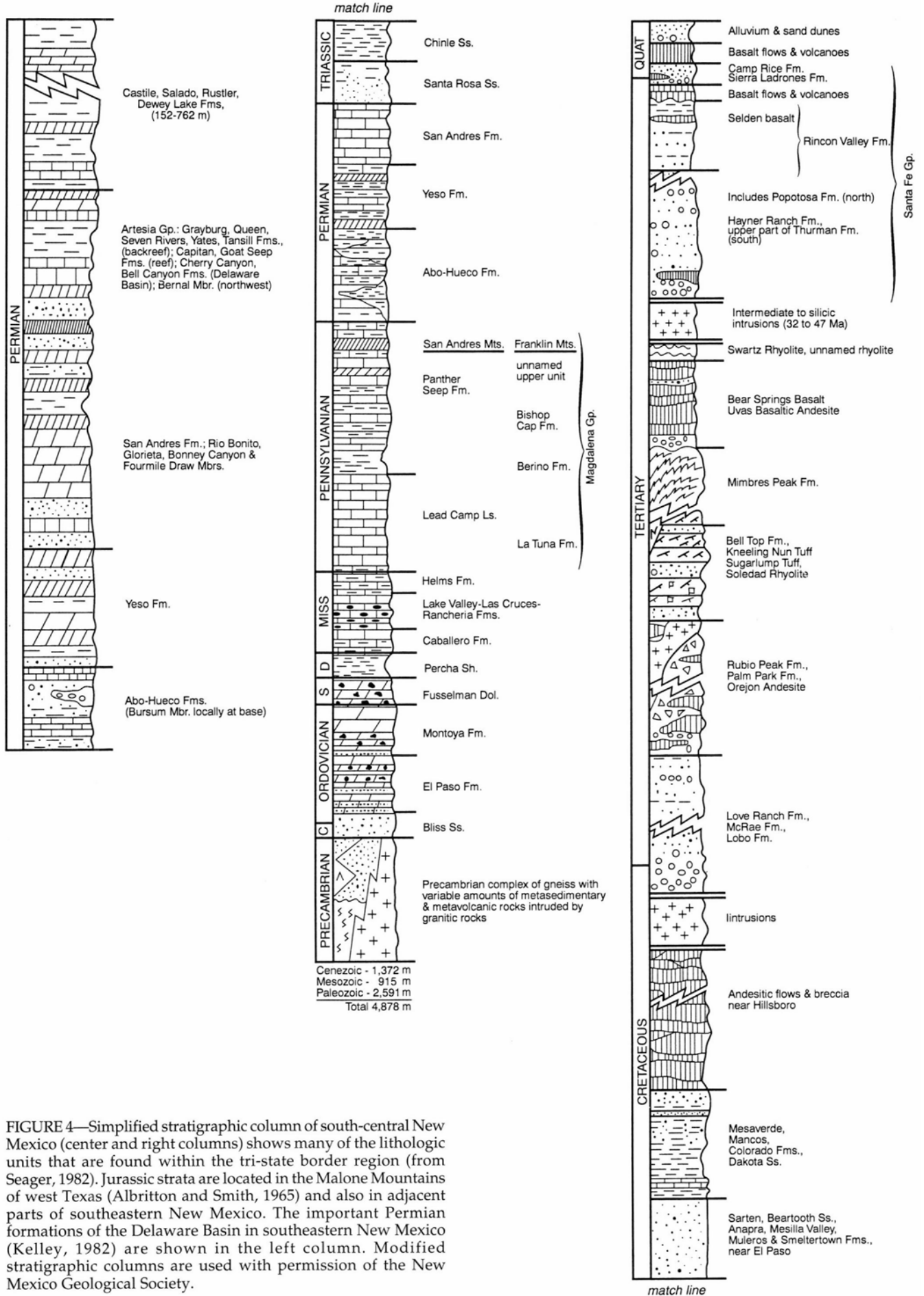

FIGURE 4—Simplified stratigraphic column of south-central New Mexico (center and right columns) shows many of the lithologic units that are found within the tri-state border region (from Seager, 1982). Jurassic strata are located in the Malone Mountains of west Texas (Albritton and Smith, 1965) and also in adjacent parts of southeastern New Mexico. The important Permian formations of the Delaware Basin in southeastern New Mexico (Kelley, 1982) are shown in the left column. Modified stratigraphic columns are used with permission of the New Mexico Geological Society.

basement of the Franklin Mountains (Deen, 1976). Examination of the stone walls that characterize the city and are still utilized because of relatively cheap labor costs, shows these two rock types along with Paleozoic limestone, dolomite, or sandstone that have been derived from adjacent overlying strata. The crystalline rocks are also used in part as aggregate for the flourishing concrete industry. The remainder of the aggregate is derived from carbonate units and also sand and gravel pits located in pediment and intermontane basins throughout the whole region.

In the Van Horn area metarhyolite from the Proterozoic Carrizo Mountain group has been used as road metal at the Gifford-Hill operation (Table 1, Fig. 2). Production commenced in 1926 and continued until about the early 1980s. Annual production was about 224,680 metric tons (mt) (McAnulty and Hoffer, 1980b) but declined in later years. The crushed stone was largely used for railroad ballast and asphalt mix.

### Architectural stone

Brucitic marble was produced by contact metamorphism of Permian (Bone Springs and Hueco) limestone and dolomite units respectively. This zone has yielded a white marble at the Texas Architectural Aggregates underground mine at Marble Canyon located 56 km north of Van Horn (Fig. 2). Operations began at this location in 1963. The brucite zone is approximately 120 m wide and up to 300 m thick, and grades from 60 wt.% brucite near the igneous contact to 20 wt.% near the unaltered dolomite (Newman, 1995; editors' note: *see* Newman and

Hoffman, this volume). Brucite is an effective TiO<sub>2</sub> extender and performance enhancer for opacity and adhesiveness in paints. It also offers flame retardant and smoke suppressant properties in polymer compounds, and so the deposit is being reevaluated (Newman, 1995; editors' note: *see* Newman and Hoffman, this volume). Another color-banded stone of Precambrian age is being exploited in open cuts by Texas Architectural Aggregates at the west end of the Alamoore talc district (Fig. 2, Table 1). This stone is being used for interior decorative purposes (Gerry Scott, pers. comm., 1995).

In Chihuahua City and to a lesser extent in Ciudad Juárez, the relatively soft ash-flow tuffs, primarily of Oligocene age, were the choice for building materials in important government and other buildings, cathedrals, and churches of the Spanish colonial period. Ornamental facades are invariably produced from these relatively soft, volcanic rocks, and ornate fountains and statues are also carved from this material. Finer-grained more-dense varieties are used on occasion as paving stones.

### Cement and concrete

These related industries primarily rely on Lower Cretaceous limestones, shale, and gypsum. Cementos de Chihuahua operates plants in Chihuahua City and Ciudad Juárez, Chihuahua, and Albuquerque, New Mexico, the latter being outside of the immediate border region. The older plant in Ciudad Juárez produces portland cement from the Cretaceous Lagrimas Formation, and is situated on the southeastern flank of the Sierra de Juárez uplift. Quarrying has been extensive since 1972. Presently, this

TABLE 1—Industrial Minerals and Rocks Located in West Texas, Southern New Mexico and Northern Chihuahua

COMMODITY, LOCALITY	MAP SYMBOL	COUNTY/MUNICIPIO	COMPANY
<i>Construction materials</i>			
Natural stone			
El Paso, TX	NS	El Paso	Various
Gifford-Hill, TX	GH	Hudspeth	Idle
Aggregate			
Numerous		Various	Various
Architectural stone			
Marble Canyon, TX	MC	Culberson	Texas Architectural Aggregates
Allamore District, TX	TAA	Hudspeth	Texas Architectural Aggregates
Cement and concrete			
Chihuahua, CHIH	CC	Chihuahua	Cementos de Chihuahua
Ciudad Juárez, CHIH	CJ	Ciudad Juárez	Cementos de Chihuahua
Jobe, TX	J	El Paso	Jobe Concrete Products
Samalayuca, CHIH	CS	Ciudad Juárez	Cementos de Chihuahua
Concrete block			
Ciudad Juárez, CHIH	PR	Ciudad Juárez	Probesa
Chihuahua, CHIH	LI	Chihuahua	Ladrillera Industrial
Ceramics			
Ancho, NM	AO	Lincoln	Idle
Sunland Park, NM (El Paso area)	AE	Doña Ana	American Eagle Brick
El Paso, TX	DT	El Paso	Dal Tile
Ciudad Juárez, CHIH	PDI	Ciudad Juárez	Productos de Barro Industrializado
Kline Mountain, NM	KM	Sierra	Idle
Labor de Terrazas (white brick)	LT	Chihuahua	Idle
Chihuahua, CHIH	I	Chihuahua	Interceramica
Ramsey, NM	R	Sierra	Idle
Sierra de Gómez, CHIH	SG	Villa Aldama	Production
Ceramic-grade talc			
Alamoore District, TX	DM	Hudspeth	Dal-Minerals (formerly Texas Talc)
Alamoore District, TX	MW	Hudspeth	MilWhite
Alamoore District, TX	S	Hudspeth	Suzrite (formerly Pioneer)
Alamoore District, TX	UC	Hudspeth	United Clays (formerly Southern Clay)
Adobe (A) Numerous			
Paquime, CHIH	P	Casas Grandes	Various
Anthony, NM	AY	Doña Ana	DeLaO Brick

TABLE 1—continued

COMMODITY, LOCALITY	MAP SYMBOL	COUNTY/MUNICIPIO	COMPANY
<i>Chemical Minerals</i>			
Potash			
Carlsbad District, NM	A	Eddy	AMAX (Horizon Potash), abandoned
Carlsbad District, NM	ECP	Eddy	Eddy County Potash
Carlsbad District, NM	IMC	Eddy	IMC Fertilizer
Carlsbad District, NM	MC	Eddy	Mississippi Chemical
Carlsbad District, NM	NMP	Eddy	New Mexico Potash
Carlsbad District, NM	WAM	Eddy	Western Ag-Minerals
Common salt			
Carlsbad District, NM	US	Eddy	United Salt
Gypsum			
Elcor Ranch, TX	ER	Culberson	"Elcor" (abandoned)
Evaporite deposits			
El Leon, CHIH	EL	Coyame	Cementos de Chihuahua
El Sabinoso, CHIH	ES	Guadalupe Bravos	Production
Cuchillo Parado, CHIH	CP	Coyame	Idle
Guadalupe, CHIH	OI	Guadalupe Bravos	Omega Industrial
Samalayuca, CHIH	S	Ciudad Juárez	Idle
Los Charcos, CHIH	LC	Guadalupe Bravos	Idle (?)
La Napolera, CHIH	LN	Villa Aldama	Idle
La Encantada, CHIH	LE	Villa Aldama	Cementos de Chihuahua
Laguna Salada del Hueso, CHIH	LSH	Villa Alumada	Idle
Barite			
Seven Heart Gap, TX	SHG	Culberson	Idle
Palm Park, Stevens, NM	PPS	Doña Ana	Idle (?)
Stevens, NM	S	Doña Ana	Idle
White Spar, NM	WS	Doña Ana	Idle
Roque y La Amargosa, CHIH	RLA	Julimes	Idle
Sulfur			
Culberson, TX	C	Culberson	Freeport McMoran
Phillips Ranch, TX	PR	Culberson	Idle
Fluorspar			
Burro Mtns., NM	BM	Grant	Idle
Cooks Peak, NM	CP	Grant	Idle
Eagle Mtns, TX	EM	Hudspeth	Idle
Fluorite Ridge, NM	FR	Luna	Idle
Gila, NM	G	Grant	Idle
Northern Sierra Caballo, NM	NSC	Sierra	Idle
Quitman Mountains, TX	QM	Hudspeth	Idle
Sierra Blanca, TX	SB	Hudspeth	Idle
Silver City area, NM	SC	Grant	Idle
Tortugas, NM	T	Doña Ana	Idle
White Signal-Gold Hill, NM	WS-GH	Grant	Idle
Hydrofluoric Acid			
Ciudad Juárez, CHIH	N	Ciudad Juárez	Norfluor
Nepheline syenite			
Cornudas Mtns. NM	CM	Otero	Addwest Minerals
Pegmatite minerals			
Northern Big Burro Mtns. - Continental Amer., NM	NBBM, CA	Grant	Idle (?)
Mica mine area, TX	MM	Hudspeth/Culberson	Idle
<i>Lightweight aggregates</i>			
Perlite			
Hermanas, NM	H	Luna	Idle
McDonald Ranch, NM	MR	Grant	Idle (?)
La Estrella, CHIH	LE	Ocampo	Minor production
Leitendorf Hills, NM	LH	Hidalgo	Idle
Pinto Canyon, TX	PC	Presidio	Idle
Pumice			
Lordsburg, NM	L	Hidalgo	Idle
Pinto Canyon, TX	PC	Presidio	Idle
Labor de Terrazas, CHIH	LT	Chihuahua	Idle
Palomas, CHIH	PO	Chihuahua	Idle (?)
Sierra de Pastorias, CHIH	SP	Chihuahua	Idle (?)
Scoria			
Santo Tomás, NM	ST	Doña Ana	Big Chief Stone
Doña Mountain, NM	DM	Doña Ana	Big Chief Stone

TABLE 1—continued

COMMODITY, LOCALITY	MAP SYMBOL	COUNTY/MUNICIPIO	COMPANY
<i>Metallurgical minerals</i>			
Ciudad Juárez, CHIH	PBI	Ciudad Juárez	Productors de Barro Industrializado
Cusihuiachi, CHIH	C	Cusihuiachi	Idle
El Magistral, CHIH	EM	General Trias	In Production
Samalayuca, CHIH	S	Ciudad Juárez	Production (?)
Sunland Park, NM (El Paso area)	AE	Doña Ana	American Eagle Brick
<i>Abrasive, filtration materials</i>			
Garnet			
Hanover-Fierro district, NM	HF	Grant	Idle
Orogrande, NM	O	Otero	Idle
Zeolites			
Winston, NM	SCM	Sierra	St. Cloud Mining
<i>Miscellaneous</i>			
Agate			
Ojo Laguna, CHIH	OL	Chihuahua	Minor production
Rancho Aqua Nueva, CHIH	RAN	Chihuahua	Minor production
Rancho El Agate, CHIH	REA	Villa Ahumada	Minor production
Rancho El Gallego, CHIH	REG	Villa Ahumada	Minor production
Beryllium minerals			
Sierra Blanca, TX	SB	Hudspeth	Idle
Geodes			
Las Choyas	LC	Villa Aldama	Minor production
Mexican onyx			
Tres Hermanos Mtns., NM	TH	Luna	Minor production
Ochre			
Los Lamentos, CHIH	LL	Villa Ahumada	Idle
Smelter slag			
El Paso, TX	EP	El Paso	ASARCO
Trinitite			
Trinity Site, NM	TS	Socorro	"Idle"
Turquoise			
Burro Mtns., NM	NB	Grant	Minor production
<i>Restricted occurrences</i>			
Carlsbad Caverns National Park, NM	CCNP	Eddy	National Park Service
Samalayuca Dune Field, CHIH	SDF	Ciudad Juárez/ Guadalupe Bravos	Unstructured
White Sands National Monument, NM	WS	Doña Ana/Otero	National Park Service

plant produces 600 metric tons (mt) of cement daily (García, 1995; editors' note: *see* García, this volume) for the domestic market. The new Samalayuca plant, scheduled to begin operations August 1995 is located on Mexico Highway 45, 30 km south of Ciudad Juárez, and 5 km north of the village of Samalayuca (Fig. 1). Construction costs will amount to \$145 M. The water supply for this facility is from wells located in the adjacent basin. Limestone and shale are obtained from the Cuchillo and Benign formations of Early Cretaceous age in the immediately adjacent Sierra del Presidio (Fig. 5). Gypsum is obtained locally from the vicinity of Los Charcos deposit (Clark, 1984), situated 40 km to the southeast, and is probably of Early Cretaceous age. Production is planned for 800,000 mt per year (mtpy), part of which will be exported to the United States.

The Chihuahua City Cementos de Chihuahua facility obtains limestone from Lower Cretaceous units in the immediately adjacent Sierra Nombre de Dios, on the eastern flank of the town. Installed plant capacity was 400,000 mtpy (de la Fuente, 1983), with an expansion project to 580,000 mtpy. Ladrillera Industrial, also located in the Chihuahua City area, has a plant capacity of 70,000 mtpy for the manufacture of cement block of export quality (de la Fuente, 1983).

During the early-to-mid 1980s the El Toro Southwestern Cement plant in El Paso closed because of limited raw material reserves and plant capacity, environmental considerations, and increased competition. Of the four ready-mixed concrete suppliers in El Paso, the Jobe



FIGURE 5—View northwards to cement plant at Samalayuca, Chihuahua, with Sierra del Presidio on skyline. Northern part of the dune field is in the foreground.

company's quarries and plant at the south entrance to McKelligon Canyon, is the largest. Their principal competitor is El Paso Redi-Mix. At the Jobe quarries the limestone is taken from Ordovician El Paso Group strata that are well exposed on the eastern flank of the Franklin Mountains. The limestone is down-faulted against Precambrian granite along the McMillan fault. Production began in 1983 and is rated at 1,800 mt per hour. The cement is imported from Chihuahua.

In the mid-1980s some 135,000 mt of crushed Cretaceous limestone was produced on American Eagle Brick property by the El Paso Sand for use as aggregate. When El Paso Sand was acquired by Jobe Concrete Products, the lease changed hands and there has been no subsequent production.

### Ceramics

The American Eagle Brick plant (formerly El Paso Brick) near El Paso has been in operation since 1897 (editors' note: *see* Cudahy and Austin, this volume). It is in Sunland Park, New Mexico, on the west bank of the Rio Grande and near the eastern flank of the Cerro de Cristo Rey laccolithic intrusion (Lovejoy, 1976). Raw materials are derived from the Mesilla Valley and Anapra Formations, both of Early Cretaceous age. These strata are upturned around the periphery of the intrusion and are exploited in several quarries. After quarrying, the shale is crushed, screened, extruded, and fired at temperatures in the 900-1,100°C range (Ntsimanyana, 1990). Bricks are distributed locally and to other population centers in west Texas, southern New Mexico, and adjacent parts of Arizona. In the last few years the operation has become more efficient and natural gas used in the tunnel kiln has been reduced from 2,790 kJ/kg to today's 1,860 kJ/kg (Cudahy, 1995; editors' note: *see* Cudahy and Austin, this volume). However, tile manufacture was discontinued because of technical and economic considerations.

A few hundreds of meters to the south on the Mexican side of the international line is the competing plant in Ciudad Juarez. Productos de Barro Industrializado, uses the same shale formations as the American company. Elsewhere in Ciudad Juarez, there are numerous small brick-making facilities. Fuel for these primitive kilns include tires, used car oil, and plastics, thereby creating significant pollution (Mendoza, 1995). Presently, engineers at Los Alamos National Laboratory are designing relatively cheap gas-burning kilns for local use in Mexico.

High-quality tile is produced in Chihuahua City by the Interceramic Company that operates several fabricating plants. The material for the tiles is quarried from the Permo-Pennsylvanian age Rara Formation (Handschy and Dyer, 1987) exposed in the eastern flank of Sierra del Cuervo (Fig. 3, Table 1). This formation represents a distal sequence of turbidities, in which shale is the most common rock type and is composed of varying proportions of clay, carbonate, and quartz. The sandstones vary in composition from quartzarenite to wackes. The unit also includes bedded chert and bentonite. The Rara Formation is intruded by rhyolitic to basaltic dikes that have locally metamorphosed the host rocks, resulting in mineralogical transformations (Clark and Holguin, 1995).

Using Italian technology, Interceramic produces floor and wall tiles at several plants in Chihuahua City. The clay and additional bentonite pass through primary and secondary crushers that process about 8,000 mt/day (mtpd). After further grinding the mixture is transformed

into a slurry that is sized, and dried before the powder is pressed into standard size tile forms. Glaze coatings are sprayed on and consist of wollastonite (derived from Zacatecas state), feldspar, calcium carbonate, and a lithium compound. Decoration is applied with colored glaze. Finally, the tiles are transferred to kilns and fired at 1,180°C until reaching a hardness of 500 kg/cm<sup>2</sup>. The resulting products are for domestic and export markets, although it should be noted the company has constructed an additional plant in the Dallas area that is scheduled to begin operation during 1995. The source of all the raw material is not known, but apparently some ball clay is transported from Kentucky (M. Madrano, pers. comm. 1995).

Dal-Tile has constructed a natural gas-burning plant in northeast El Paso that began production in October, with a capacity of 2.0 million m<sup>2</sup> (22M ft<sup>2</sup>) of wall tile per year (R. Williams, pers. comm., 1995). Equipment used in the plant is of Italian origin. The raw materials include clay from the Troup Operations in east Texas, limestone from the Austin area, and ceramic-grade talc from the Dal-Minerals mine in the Allamore district of west Texas. The raw materials are ground up in a continuous ball mill with silica pebbles used as the grinding media. The slip from the continuous mill is passed through a spray dryer that reduces the water from 35% to 5%. This powder is then pressed into 11.4 x 11.4 cm (4 1/4 x 4 1/4 inch) tiles, dried to less than 1% moisture, passed through a roller hearth kiln, and fired at about 1,150°C. The glaze is applied and then fired again to about 1,120°C.

**Kline Mountain kaolin deposit**—This deposit is situated on the northwestern flank of Kline Mountain in the Black Range uplift, Sierra County, New Mexico (Fig. 1). The deposit was discovered by F. L. Schneider in 1958. Samples were examined in 1962 and 1980 in some detail by the private sector for use as paper coater. However, fine-grained silica (cristobalite and/or tridymite) within the kaolin has been reported as a major drawback for use in the paper industry. The stratigraphy in the Kline Mountain clay deposit area is composed of mid-Tertiary bimodal volcanic and volcanoclastic deposits that consists of basaltic andesite lavas, high-silica rhyolite lavas, and pyroclastic material (Isik et al., 1994). The kaolin deposit occurs as a result of hydrothermal alteration within the advanced argillic zone of Kline Mountain tuff. Clay minerals, silicification, volcanogenic materials, and textures indicate a hydrothermal origin.

The entire Kline Mountain deposit reportedly has 180 million mt reserve with 38-39% Al<sub>2</sub>O<sub>3</sub> and a very high standard brightness of 94%. The production of kaolin is by open-pit-mining methods. About 815 mt of rock were sold in 1969 for use as an oil absorbent by Union Oil. After screening crushed kaolin ore was shipped by trucks to Truth or Consequences, New Mexico, for transshipment and final use in the Santa Barbara Channel oil spill.

Clay from the Kline Mountain deposit was used experimentally to make ceramic tile, using admixtures of #1 and #3 clay from the American Eagle Brick plant near El Paso and other additives. The fired-brick specimens produced at American Eagle Brick demonstrated excellent white color properties. The bright whiteness of the fired specimen can give more market flexibility by producing various shades of light-colored brick from Kline Mountain kaolin. By adding from 15 to 50 wt.% #3 and/or #1 clay from the Sunland Park deposit (Fig. 1; Table 1), in the El Paso area, with nepheline syenite to the kaolin, a com-

plete range of white-to-gray brick can be produced. This mixture has the additional advantage of lowering the cost of producing white brick, because the #3 and #1 clays have negligible transportation cost to the firing plant.

An economic evaluation by Isik (1993) shows that on the average, the available clay is composed of kaolinite (40.7 wt.%), alunite (16.4 wt.%), silica (37.9 wt.%) and accessories (1.12 wt.%). The amount of clay available, for which there are chemical and mineralogical controls, is probably 3,160,000 mt. On the basis of this evaluation and by manufacturing white brick in the existing plant near El Paso, the Kline Mountain deposit is found to be economically viable under the projected conditions.

### Ceramic-grade talc

The geology of the Allamore district and its mineral resources have been described by King and Flawn (1953), McAnulty and Hoffer (1980a), Bourbon (1981, 1982), Rudnick (1983), Edwards (1980, 1984), Kyle and Clark, (1990), Soegaard and Callahan (1994), and Clark (1995d). Talc is located in the Allamoore Formation that stratigraphically overlies the 5,800 m thick Carrizo Mountain Group. This group exhibits metasediments interbedded with metarhyolite and felsic tuffs dated at 1.27 Ga (Rudnick, 1983). The Allamoore Formation is 490 m thick at Tumbledown Mountain (King, 1980) and consists of mafic volcanic flows, carbonate units, and talcose phyllite. It is unconformably overlain by the Hazel Formation and the Van Horn sandstone both of Proterozoic age.

Tectonic events include folding and faulting of the Allamoore and Hazel Formations about 1.0 Ga ago when rocks of the Carrizo Mountain Group were thrust northward along the Streeruwitz thrust. The resultant pressure-temperature conditions produced greenschist-grade metamorphism, locally to biotite-grade (Edwards, 1984), and talc was formed from magnesium-rich carbonate rock protoliths in the Allamoore Formation. The talcose phyllite occurs in discontinuous lenses, usually less than 150 m thick and 1.6 km in length and are generally enclosed within carbonate units. Later, erosion followed by folding took place in Late Pennsylvanian time so that the Lower Permian Hueco Limestone rests unconformably on Proterozoic units.

Talc production began in 1952 and by 1988 had reached 237,000 mtpy (Virta, 1988). The active talc producers are Milwhite at Tumbledown Mountain, Suzrite (formerly Pioneer), Dal Minerals (Texas Talc), and United Clays (Southern Clay) (Fig. 2, Table 1). Production is by open-pit methods, and the rock is sent to primary crushers. Dolostone and chert are then removed by hand sorting (Kyle and Clark, 1990). Secondary crushers reduce particle size to minus 2.5 cm, and the material is fed into gas-fired rotary kilns for calcining. The resultant hard, white-to-light gray material is an artificial diopside used in the ceramic industry. Milwhite and Suzrite operate beneficiation plants in the Van Horn area.

### Adobe

The last of the construction materials considered in the border region has been used for the greatest period of time. Adobe is used because of the abundance of the clay materials and low costs of manufacture. While a small number of modern buildings are made from this material (Austin and Goolsby, 1995; editors' note: see Austin and Goolsby, this volume), adobe bricks are widely used in relatively low income communities, and the structures,

many of which are homes, are completed when time permits. Alluvium is a common source of the clay and inspection of these bricks shows a significant fraction of quartz grains and small rock particles as well as straw. Sun-dried bricks are commonly made in wooden molds, eliminating fuel costs that are a major consideration in fired-brick kilns. Hydraulically pressed mudblocks and rammed-earth walls, the latter in which layers of moistened mud are placed between forms and tamped, are less frequently employed (Austin and Goolsby, 1995; editors' note: see Austin and Goolsby, this volume). Adobe bricks are commonly covered with a plaster that provides a smooth finish to the building and prevents weathering of the brick. In many modern urban areas, plaster walls cover buildings made from concrete block, and consequently the structure is not authentic.

The oldest recorded use of adobe in the region under consideration is at Paquime, inhabited from the 12th through early 14th centuries, 5.5 km to the southwest of Nuevo Casas Grandes in northwestern Chihuahua (Fig. 3). Today Paquime is a large complex of ruined, multi-storied, adobe apartment buildings, pyramids, Meso-American ballcourts, and plazas (DiPeso et al., 1974; Gerald, 1983). The Spanish created several missions at Socorro, Texas; Mesilla, New Mexico; and elsewhere, where unfired adobe bricks were the primary building materials used. Many are preserved to the present.

## Chemical minerals

### Potash

The Carlsbad potash district is of national and international importance because it serves a significant part of the American fertilizer industry that derived its raw material from Europe before World War I. Today the Carlsbad potash production is in competition with Canadian producers, principally in Saskatchewan. The following summary is largely drawn from Walls (1985), Austin and Barker (1990), Williams-Stroud (1995), and Barker and Austin, 1995 (editors' note: see Barker and Austin, this volume).

The U.S. potash district was developed because of the World War I embargo on German potash, the only large source at that time, but with prices over \$550 /mt (Walls, 1985). As a result, wartime potash (for saltpeter) was produced at over 100 small plants, mainly in Nebraska and California. In New Mexico, potash was discovered in 1925 in Eddy County, in the Snowden and McSweeney Oil Company well No. 1 on a V. H. McNutt permit near the center of what is now called the Known Potash Leasing Area (KPLA). Potash was cored in April 1926 and the Federal Potash Exploration Act was passed in June. By 1934, at least 11 companies were exploring for potash in southeastern New Mexico (Austin and Barker, 1990).

Potash production in the Carlsbad district comes from evaporite sequences in the McNutt Member of the Upper Permian (Ochoan Series) Salado Formation (Fig. 4). The Salado Formation is a halite dominated sequence with 200-400 m of halite in the KPLA (Lowenstein, 1988). The McNutt Member is approximately 120 m thick and contains 11 actual or potential potash zones that are 1-3 m thick.

The principle potassium-bearing minerals are carnalite ( $\text{KCl} \cdot \text{MgCl}_2 \cdot 6\text{H}_2\text{O}$ ), langbeinite ( $\text{K}_2\text{SO}_4 \cdot 2\text{MgSO}_4$ ), polyhalite ( $\text{K}_2\text{SO}_4 \cdot \text{MgSO}_4 \cdot 2\text{CaSO}_4 \cdot 2\text{H}_2\text{O}$ ), sylvite (KCl), and sylvinite (KCl+NaCl). Potassium products from New Mexico are sylvite or muriate of potash (MOP), langbein-



ite or sulfate of potash-magnesia (SOPM), and an artificial potash product ( $K_2SO_4$ ). MOP comprises 70% of Carlsbad production, whereas SOPM accounts for 30% (Austin and Barker, 1990).

Potash mining is by underground shaft mines that employ room-and-pillar methods. Continuous mining equipment as well as drill-and-blast techniques are used, and beds as thin as 1.2 m are mined with boring equipment. Room-and-pillar mining allows 60-65% ore recovery, and subsequent removal of pillars allows extraction to exceed 90% (Sullivan and Michael, 1986). Beneficiation includes grinding, separation, flotation, centrifuging, drying, and screening; vacuum recrystallization is used on clay-rich or fine-grained ores (Austin and Barker, 1990).

At the close of 1993 five companies operated underground mines in the Carlsbad potash district (Fig. 2, Table 1); Eddy County Potash, IMC Global, Mississippi Chemical, New Mexico Potash, and Western Ag-Minerals (Searls, 1994). Horizon Potash shut down permanently on April 23, 1993, citing the low price of potash as the reason (Searls, 1994). These New Mexico producers account for 82% of the total domestic marketable potash production. Ore production in New Mexico was 1.23 million mt in 1993 (Barker and Austin, 1995; editors' note: *see* Barker and Austin, this volume). The average  $K_2O$  content of the ore is 12.5 equiv. wt.%. The current price of potash as muriate is \$100-110/mt (Industrial Minerals, June, 1995).

Since 1993, AMAX (later Horizon Potash) has ceased operations. IMC Fertilizer has become IMC Global. Potash close to the Waste Isolation Pilot Project (WIPP) that is included in the KPLA (Austin and Barker, 1990), is excluded from mining.

### Common salt

A historical marker 120 km south of Carlsbad on U.S. Highway 62-180 on the west side of the Salt Lake graben reads "Resentment over private control of the Salt Lakes in this region, often called Guadalupe Lakes, led to the El Paso Salt War, 1877, which entailed the loss of many lives and much property." The Salt Flat graben contains a series of fine-grained gray carbonate and sulfate muds interbedded with thin gypsum and algal beds, that reflect salinity and fluid-level changes. Near the deflation surface sulfate is being reduced by bacteria, and small amounts of native sulfur occur. Inflowing groundwater is dominated by Ca—Mg— $SO_4$  compositions, and brines are seldom modified by surface water percolation (Boyd and Kreidler, 1987).

A large part of Delaware Basin evaporite deposits, particularly the Salado Formation, contains halite. Today the United Salt plant, adjacent the IMC mill and beneficiation plant, produces sodium chloride brine for various uses including well-drilling fluids. The Salt Lake, situated approximately 16 km to the south, is one of several brine lakes. Although Salt Lake predates potash mining, it is now maintained principally from potash processing discharge.

### Gypsum

Some 400 m of Castile Formation gypsum and anhydrite were deposited on the immediate basin side of the Capitan Reef south and east of the Capitan reef escarpment. This formation is exposed at the surface as a Gypsum Plain. Anhydrite with thin, intercalated, organic-rich calcite laminae creates the finely-banded nature of the Castile Formation. Kirkland and Anderson (1970) con-

cluded that zones of anhydrite/carbonate couplets extend for tens of kilometers, based on core examinations, and that microfolding is attributable to Cenozoic tectonic events. However, Borns (1987) suggested that while deformation from tectonic events may have occurred at several different times, including the Cenozoic, associated soft-sediment deformation and volume changes induced by the anhydrite—gypsum transformation are also important.

At the abandoned Elcor plant in the southern Delaware Basin, a railroad spur to the plant extended from the main line at Kent (Fig. 2). In 1980 gypsum was being shipped to an Odessa—Midland cement plant for use in the production of portland cement (Hills et al., 1980). The Elcor plant was designed to produce sulfur from gypsum mined at the adjacent Rock House quarry. Construction of the plant started in 1968, and small quantities of sulfur were produced and sold in 1969 and 1970. The operation was shut down in 1970 because of a sharp decline in the price of sulfur (Hills et al., 1980).

### Sodium sulfate

A small salt flat (300 x 100 m) situated 5 km north of Samalayuca, Chihuahua, and on the west side of Mexico Highway 45 (Fig. 1, Table 1) contains several sulfate minerals. These include thenardite, epsomite, and mirabilite (Garcia, 1974). Apparently they were leached by groundwater and redeposited at or near the surface as efflorescent crusts in a closed basin, of which there are several examples in northern Chihuahua. The provenance of the sulfate is not clear but dolomite or volcanic rocks are possible sources. A mineral water was produced and bottled bearing the name *Agua de Samalayuca*; several bottles were found in and near the empty shell of the plant. The plant, which was operated for an unknown period of time, consisted of two buildings, one equipped for refrigeration of the brine, the other was used for bottling the water. Refrigeration was employed to separate sodium sulfate from sodium chloride in the brine. The cellulose plant at Anahuac, Chihuahua (Fig. 3), was mentioned as a possible potential purchaser of the sodium sulfate product.

Geophysical studies were made at the Samalayuca deposit by Flores (1956) employing electrical potential and resistivity surveys to determine different salt concentration values at varying depths in the deposit. The results of these measurements indicate there are three well-defined zones in the deposit. The uppermost includes the surface to a depth of 1.2 m of crystallized thenardite; the second is a richer zone of sulfates from 1.2 m to an average depth of 34 m. The third, lowermost zone, from 34 m to an average depth of 46 m contains evaporite minerals that have been diluted by a bentonitic mud layer and also contains an increased amount of gypsum. The average concentration of salts is 36.7 wt.%, and, using a specific gravity of 1.24, the amount of evaporite salts were calculated at 2.6 million mt.

Several other evaporite deposits are known in northern Chihuahua (F. E. de la Fuente, pers. comm. 1995) and are shown on Figure 1 and in Table 1. La Encantada deposit is the sole producing locality at the present.

### Barite

The Seven Heart Gap barite deposit (Fig. 2, Table 1) is near the topographic gap between the Delaware Mountains and the Apache Mountains. This deposit is near the



intersection of WNW structures of the Apache Mountains and the NNW-trending structures of the western flank of the Delaware Mountains. Most of the barite is located in a NNW-trending graben but some deposits are displaced by faults (McAnulty, 1980). Barite was discovered prior to 1930, and there are brief descriptions by Evans (1946) and Wood (1968). Continental Minerals mined a few thousand metric tons from the deposits in the late 1950s and early 1960s. Later, Murray (1978) and McAnulty (1980) provided more information including limited geophysical and shallow drilling data, respectively. According to Kyle (1990), Coastal Oil and Gas accomplished more drilling in the early 1980s but the results are unknown, except for the lack of further mining activity.

Barite deposits occur in the Castile Formation, overlying the transition zone from Capitan off-reef talus to basal deposits of the Bell Canyon Formation (McAnulty, 1980). The deposit is characterized by local deformational features, including collapse zones, contorted bedding, and steeply dipping beds. Two open pits were developed and the major barite concentrations appear to be confined to the basal 12 m of the Castile Formation. Barite occurs as white, intergrown crystals within dark brown limestone beds or breccias. Several previous investigations have suggested that barite formed by replacement of selected Castile strata. Some ore is stratabound and the largest deposit averaged 27 wt.% (McAnulty, 1980). The barite content in collapse breccias is similar to the bedded deposits. Barite also occurs in the lower part of the Castile Formation. On occasion the two types of deposit grade into one another.

Kyle (1990) measured homogenization temperatures in primary inclusions in blue barite crystals which indicated less than 75°C. His measured sulfur isotope characteristic shows that the Seven Heart Gap barite deposits are slightly to moderately heavy with  $S^{34}$  ranging from 17.8 to 37.2%. This characteristic coupled with low temperatures of the mineralizing fluid is suggestive of bacterial fractionation. Also, calcites from this deposit averaged  $\delta C$  of -2.5‰, and  $^{18}O$  for the Seven Heart Gap limestones fall in the range of -10 to -13‰. By comparing these isotope data with modern and ancient environments, Kyle (1990) concludes that barite concentrations at Seven Heart Gap appear to be the result of older mineralization processes, perhaps as old as Permian, whereas barite found in the Rustler Springs sulfur district (Culberson mine area) is middle Miocene or younger. The presence of laminated barite blocks within the overlying Rustler solution breccia is also evidence of relatively early mineralization. Thus, low-temperature, low-salinity, barium-bearing formation waters from the basal clastic units were introduced into the basal sulfate-rich Castile along the basin/ shelf margin where barite precipitated.

Barite deposits in New Mexico occur in a belt that is approximately parallel to the Rio Grande rift valley. Numerous occurrences are known in the southern and central part of the state. In the border region, the Palm Park, Stevens, and White Spar mines are the most important and have produced barite (Williams, 1965).

The Palm Park and adjacent Horseshoe deposits (Fig. 1) of the southern Caballo Mountains occur in saddle reefs at or just below the Silurian Fusselman Dolomite-Devonian Percha Shale (Fig. 4) contact along northwest-trending asymmetrical anticlines. The deposits are predominantly composed of jasperoid with veins containing barite-fluorite-quartz-calcite mineralization and pervasive

iron and manganese oxides and gypsum (Filsinger, 1988). The main ore zone is underlain by unaltered to silicified Fusselman Dolomite that is locally transected by northeast-trending veins of subhedral to anhedral barite, and usually northwest-trending jasperoid veins. Mineralization may be of Miocene age and barium-bearing. Rio Grande rift-related magmatic-hydrothermal solutions probably ascended rift fractures to the base of the Percha Shale where they were trapped.

Mining at the Palm Park mine was by open-cut methods, and a shallow drilling program conducted for Callahan Mining Corporation allowed estimates of ore grade and reserves. The Palm Park deposit contains 1.36 million mt of ore averaging 27 wt.% barite and 1-3 wt.% fluorspar. The Horseshoe deposit contains an estimated 45,000 mt of 5-20 wt.% barite and 1-2 wt.% fluorspar (Filsinger, 1988).

### Sulfur

Sulfur occurrences have been known in the Delaware Basin since 1854 (Skeats et al., 1902), and by the early part of the century small surface prospects and mines were producing sulfur from the eastern Gypsum Plain and Rustler Hills (Culberson mine) areas (Hentz, 1990). After a long hiatus, sulfur exploitation resumed in Trans-Pecos Texas during 1964 and large deposits were found in Culberson and northern Pecos Counties during the late 1960s (Fig. 2). The Culberson mine is the largest deposit, and geologic reserves were originally calculated at 82.8 million mt. Cumulative production from 1969, when mining began, through late 1995 amounted to 43.6 million mt using the Frasch process (J. Crawford, pers. comm. October 1995). Past daily production of 6,100-7,100 mt made the Culberson mine the largest sulfur-producing mine in the western hemisphere, although daily production has since been reduced to about 2,845 mt because of depressed prices.

The Culberson ore body is a stratabound bioepigenetic deposit (Ruckmick et al., 1979). The Salado and Castile Formations are the most economically important. Present Culberson production is from the Salado, whereas the inactive Phillips Ranch deposit produced from the lower Castile Formation. Mineralization is localized by faults and fractures developed in post-Ochoan time (Smith, 1978; Hentz and Henry, 1989). Faults acted as conduits along which ground water rich in hydrocarbons and bacteria migrated vertically and became trapped in contact with sulfate-bearing evaporites. The bacteria oxidize hydrocarbons as a source of energy by using sulfate ions (Kirkland and Evans, 1976). The resulting products are secondary calcite and hydrogen sulfide as follows:  $CaSO_4 + CH_4 (+ bacteria) \rightarrow H_2S + CaCO_3 + H_2O$ . The hydrogen sulfide then becomes oxidized and results in deposition of elemental sulfur. At the Culberson mine, alteration and sulfur mineralization in the Castile Formation continue upward into the much larger Salado orebody (Crawford, 1990). The orebody lies in the upper half of the Salado Formation and within the Rustler Hills graben. This fault-bounded structure is enhanced by dissolution of sulfate and halite-bearing strata.

Elemental sulfur occurs as (1) mineralization disseminations in gray secondary limestone or cave-fill breccias, (2) crystals lining voids in limestone, and (3) coarsely crystalline crusts that nearly fill all voids in the limestone (Crawford, 1990). Calcite, aragonite, barite, and celestite are associated with native sulfur. Finally, the age of sul-

## PREFACE

The Proceedings Volume for the 31st Forum on the Geology of Industrial Minerals is dedicated to the memories of Bob Bates and Pat Clark. Bob, the founder of the Forum, died on June 21, 1994, before he could attend the 31st annual meeting. Bob had attended all 30 previous Forums and we miss his wisdom and wit. Pat Clark, wife of Ken Clark, our field trip leader, died on June 29, 1995. Pat fully expected to attend the Forum's many functions, but a long and arduous illness prevented it. All of the Forum's participants benefited from Ken's work on the field trips and his keynote address. Through it all, Pat's encouragement kept Ken going.

Five articles in this volume were not presented in El Paso, but came from a session on industrial minerals in New Mexico at the 1994 Annual Meeting of the Society for Mining, Metallurgy, and Exploration (SME) in Albuquerque, New Mexico. These updated articles (on mica, nepheline syenite, humates, perlite, and limestone) add information about several industrial minerals and that were not covered in the Forum.

The 31st Forum on the Geology of Industrial Minerals was held at the Marriott Hotel in El Paso Texas, from April 23 through April 28, 1995. The meeting was co-hosted by the New Mexico Bureau of Mines and Mineral Resources and the El Paso Geological Society. Although held in Texas, the meeting was designed to focus on the industrial minerals of the borderland region of Mexico and the United States, specifically the border states of Chihuahua, Texas, and New Mexico. Supplemental financial support came from the Society of Economic Geologists, ECC International, New Mexico Travertine, and St. Cloud Mining Company. Their help is gratefully acknowledged.

The 31st Forum was attended by 132 participants from 25 U.S. states, 2 Mexican states, 6 Canadian provinces, and 2 other countries. The Forum is not only the premier North American industrial mineral group, but it has influence on an international scale as evidenced by some of the papers given at the meeting. The two-and-one-half days of technical sessions focused on the industrial minerals of the Borderland region, and included presentations on industrial minerals in other parts of the world. As is true of most Forums, field trips were a big part of the meeting. This meeting had both pre- and post-meeting trips, one trip as a break during the technical sessions, and three trips after the technical sessions near the end of the Forum week.

The field trip leader, Ken Clark of the University of Texas at El Paso, had an ambitious schedule of trips beginning with a pre-meeting trip on Saturday and Sunday to visit an Interceramica clay factory in Ciudad Chihuahua, about 200 mi south of El Paso. On Tuesday after a day and a half of oral presentations, participants enjoyed an afternoon field trip into Chihuahua to the new Cementos de Chihuahua cement plant nearing completion and the Norfluor fluorine production facilities, both near Samalayuca. A Mexican fiesta at the Campestre Country Club in Juarez capped off the day. Of the two field trips that left Thursday morning, the one-day trip was to the American Eagle brick plant, Ft. Selden (an adobe fort from the 19th century), White Sands National Monument, the Space Hall of Fame in Alamogordo, and

a garnet occurrence, all in New Mexico. After a delay due to bus problems, the two-day trip left for the Culberson frash sulfur mine near Orla, Texas, IMC Global potash mine east of Carlsbad, New Mexico, and Carlsbad Caverns National Monument on the way back to El Paso. On Friday a one-day west Texas trip left for the Allamoore Talc district and the Texas Architectural Aggregate mine of white brucitic marble. Finally, the post-meeting trip left El Paso on Saturday by van-to-bus-to-train for a four-day trip to Copper Canyon (Barrancas de Cobre) in Mexico's Sierra Madre Occidental. The cooperation and generosity of the companies and park and monument personnel that helped make these trips possible was especially appreciated.

Guest trips have become increasingly important as more Forum members bring their wives, husbands, and children to visit the interesting places where these meetings are held. The 31st Forum had three guest trips. On Monday a local guide helped guests tour various businesses in El Paso. On Tuesday guests toured Juarez with guide ending up at the Campestre Country Club for the fiesta with other Forum participants. On Wednesday guests took a van to the reconstructed and picturesque New Mexico village of Mesilla where Billy the Kid was tried in the 1880s.

The host state organization for this Forum was the New Mexico Bureau of Mines and Mineral Resources. Although this was the first Forum for which the host state geological survey was not the survey for the state where the meeting was held, several of the field trips and many of the presentations were concerned with New Mexico. Tasks connected with putting on a Forum were borne by members of the New Mexico Bureau of Mines and Mineral Resources. Registration was ably handled by Gretchen Hoffman, Judy Vaiza and Norma Meeks. Field trips leaders included Ken Clark, Greg Garcia, Gretchen Hoffman, Jim Barker, Virgil Lueth, and George Austin. Editing of the Proceedings Volume was by the team of George Austin, Gretchen Hoffman, Jim Barker, Jiri Zidek, and Nancy Gilson. Typing and re-typing of manuscripts was by Terry Telles and Lynne Hemenway. Drafting at the Bureau was by Kathy Glesener, Becky Titus, and David McCraw. Charles Chapin, Director of the New Mexico Bureau of Mines and Mineral Resources, supported the 31st Forum from the beginning when he was asked whether or not the Bureau could host a meeting that was to be held in El Paso. In addition, he allowed fees not used in the course of the meeting or for the proceedings to be contributed to the Robert L. Bates Scholarship Fund, a fund established to bring students interested in industrial minerals annually to the Forum.

Finally, a special thanks is extended to all of the Forum speakers and authors who took the time and effort to prepare the articles presented in the Proceedings Volume. All at the New Mexico Bureau of Mines and Mineral Resources hope that you are satisfied with our efforts.

George S. Austin  
New Mexico Bureau of Mines  
and Mineral Resources and  
31st General Chair

fur formation is regarded by Crawford (1990) as post-Cretaceous, a relatively recent event related to karst development, formation of discordant breccias, and the infiltration of hydrocarbons into the western Delaware Basin.

### Fluorspar

Several localities in the tri-state border region produced fluorspar in the past, but none are currently active. In west Texas one of the best known deposits is in the Eagle Mountains (Evans, 1943) southwest of Van Horn (Fig. 2; Table 1). More than 30 fluorspar occurrences are known in fissure veins along faults that cut a variety of igneous and sedimentary rocks. Fissure veins in east-west and northeast-trending normal faults appear to offer the greatest potential for commercial deposits, although bedding replacement deposits along bedding-plane faults have yielded most of the fluorspar in the district. Most of the 10,900+ mt of fluorspar shipped from deposits in the Eagle Mountains came from the Spar Valley area (McAnulty and Hoffer, 1980b). Other deposits in west Texas and Brewster County include those at Mariscal Mountain in Big Bend National Park, Christmas Mountains, and in the Terlingua mercury district (McAnulty, 1967) but are beyond the region under consideration. Further to the northwest other localities (Fig. 2) include the Quitman Mountains and Sierra Blanca (McAnulty, 1980; Rubin et al., 1990).

In southwestern New Mexico numerous localities have produced fluorspar in the past. Production began in the early 1880s and reached a peak in 1944 (Davis and Greenspoon, 1946). Shipments were mainly metallurgical- and acid-grade concentrates. However, as noted by Van Alstine (1965), New Mexico production essentially ceased in 1954, largely because of depressed prices and inability to meet foreign competition, mostly from Mexico. Figure 1 shows the location of deposits with greater than 18,100 mt of crude fluorspar production. In the northern Sierra Caballo, Burro Mountains, Cooks Peak, Fluorite Ridge, and Tortugas deposits, fluorspar is closely associated spatially and possibly genetically with intrusive or extrusive igneous rocks of Late Cretaceous or Tertiary age (Van Alstine, 1965). Other deposits of note include the Gila district, Silver City area, and White Signal-Gold Hill district. In southwestern New Mexico several other deposits have had minor production (less than 4,500 mt crude fluorspar). The area also has fluorite occurrences, principally associated with other mineral deposits of value.

**Hydrofluoric acid**—The Norfluor acid plant is on the west side of Mexico Highway 45, from Ciudad Juarez to Chihuahua City, south of Ciudad Juarez (Fig. 1). The Norfluor operation is a subsidiary of LCI, Jacksonville, Florida. The plant was first constructed in 1979 and rebuilt in 1989 to take advantage of a new process of HF manufacture. There are 185 employees, including office staff, medical clinic, and on-site pollution monitoring equipment.

The principal raw material is acid-grade fluorspar (97.5%  $\text{CaF}_2$ ) that is shipped by rail from Las Cuevas mine, San Luis Potosi, a distance of 1,200 km (Clark, 1995a). Some 45,000 mt of ore are consumed by the plant per year, and 2.2 mt of fluorspar are needed to produce one metric ton of HF acid. The wet-cake fluorspar is dried and passes through four refining steps of distillation and condensation after reaction with sulfuric acid and oleum at 400°C

in a horizontal cylindrical reactor. The sulfuric acid used is from a byproduct of Mexico's two largest porphyry copper deposits at Cananea and La Caridad, Sonora. The computer-controlled plant is operated under vacuum, to reduce hazards, and the resulting product is 99.99% pure anhydrous HF acid. The anhydrous product, 100% of which is bound for USA, is used in manufacture of high-grade gasolines and aluminum among other applications. The HF acid is distributed in specially constructed rail and road tankers.

A 70% acid solution product is produced by dilution with water. Another product is made by reaction with ammonia to produce ammonia bifluoride (ABF) that is used in glass finishing, and the electronic and oil well industries. It is one of only three plants in the world that produces ABF, and the only producer in North America. The ABF flake is sold in solid form in 22.7 kg (50**lb**) units, and bagged at the plant. A byproduct is potassium fluoride (KF). In Mexico and many developing countries, KF is added to table salt, which substitutes for fluorinated water, common in other parts of North America and European countries. Silica is another byproduct from the Norfluor plant. The raw fluorspar contains 1.5 wt.% finely divided silica that combines with the HF acid to produce silica tetrafluoride ( $\text{SiF}_4$ ). Following absorption in water, hydrofluoric silicic acid (HFS) is produced, and this is then neutralized with ammonia to produce ammonium fluoride, which is also distributed in rail tank cars. The silica is separated, washed, dried and sold for use in computer chips. Finally, an obvious, mostly unused byproduct from the plant is the ever-increasing mound of anhydrite, which Ciudad Juarez uses in pavements.

### Nepheline syenite

Within the Cornudas Mountains in the northern Trans-Pecos alkalic province and adjacent areas of southern New Mexico, the Wind Mountain nepheline syenite is one of ten laccoliths and stocks (editors' note: see McLemore et al., this volume). Recently, Adwest Minerals began exploration and development of the Wind Mountain nepheline-syenite porphyry for use in dark-colored glass, flat-glass, and ceramics (McLemore and Guilinger, 1993). Nepheline syenite, produced in Arkansas has been used as an additive to depress required kiln temperatures at the American Eagle Brick plant (Ntsimanyana, 1990). Thus, the potential local use of this rock is enhanced by the proximity of the Wind Mountain deposit to the ceramic industries in El Paso. Other potential uses include silica-free abrasives, roofing granules, and dimension stone (McLemore et al., 1995; editors' note: see McLemore et al., this volume).

### Pegmatite minerals

Pegmatites are found in granites and metamorphic terranes of New Mexico, and several localities exhibit these coarsely crystalline rocks within the tri-state border region. In Grant County six localities are known, stretching from the northern Big Burro Mountains to the Continental American areas (Lesure, 1965). Pegmatites have also been identified in the northern Cooks Range, Caballo Mountains, San Andreas Mountains, and the Organ Mountains. Apparently the production of mica, feldspar, and other minerals from these deposits has been scant.

The Mica mine in the Van Horn area (Fig. 2) is the only area in west Texas where pegmatites have been exploited (Flawn, 1951; Garner et al., 1979). Mica and feldspar were

discovered in the early 1890s, but there was limited production of these minerals in subsequent years. The Carrizo Mountain group of Proterozoic age is the host rock.

### Lightweight aggregates

#### Perlite

New Mexico has been a leading producer of perlite in the past (Weber, 1965), and commercial production reportedly began in 1947. Perlite distribution is tied to the occurrence of volcanic fields of Tertiary or Quaternary age where the silica glass can be expanded because of the small percentages of contained water. The principal deposits lie west of the Rio Grande, and many of the large commercial deposits are located in the northern and central parts of the state.

Several localities occur in southwestern New Mexico, but production has been very small. There are some localities in Grant County (Weber, 1965), and mining along Burro Cienega took place in 1953 on the McDonald Ranch and surrounding area (Fig. 1), followed by expansion at Gage, Luna County. A small deposit occurs near Hermanas, but no production is recorded. In the Leitendorf Hills 13 km south-southwest of Lordsburg, small intermittent production occurred during 1950-53 (Flege, 1959).

In Presidio County, west Texas, there is an abandoned perlite mine in the Pinto Canyon area (Amsbury, 1958; Cofer, 1980). In westernmost Chihuahua, perlite is known at La Estrella deposit (Fig. 3) near the newly paved road that crosses Sierra Madre Occidental, connecting Chihuahua City with Hermosillo, Sonora.

#### Pumice

New Mexico has been a leading producer of pumice for several years, and there are several deposits in the western part of the state. However, the major producing areas around the Valles Caldera are north of and outside the border region. The only deposit within this region is south of Lordsburg (Fig. 1), where only a small amount of pumice aggregate was mined in 1950 (Weber, 1965). In Chihuahua, pumice is found in volcanic rocks of Oligocene age at Palomas and at Sierra de Pastorias, both located a few kilometers west of Chihuahua City. The Labor de Terrazas rhyolitic tuff deposit (Fig. 3) is in this area and was used in the past for the manufacture of white brick (F. de la Fuente, pers. comm. 1995).

#### Scoria

These basaltic-to-basaltic andesite volcanic cinders and flows are widely distributed in New Mexico. In the region under consideration, production is confined to Dona Ana County, New Mexico. Scoria deposits are commonly associated with cinder cones of Quaternary age (Anthony and Poths, 1992), primarily located on the western flank of the Rio Grande rift valley (Hoffer, 1969) and in the west Potrillo Mountains. Present production is from Santo Tomas and Dona Mountain (Fig. 1, Table 1). The scoria is used for landscape decoration and lightweight-block manufacture.

### Metallurgical materials and siliceous smelter flux

Both American Eagle Brick and Productos de Barro Industrializado have supplied the nearby ASARCO copper smelter with flux in recent years. The rock is obtained

from the Anapra Sandstone of Late Cretaceous age that crops out on the eastern flank of Cerro de Cristo Rey (Lovejoy, 1976; Ntsimanyana, 1990). Reduced haulage costs make this material attractive when compared to greater distances needed to bring siliceous, fissure-vein gangue from Lordsburg or other mining districts in southwestern New Mexico. However, the sandstone is devoid of any valuable metal content when compared to the other sources.

The quartz-sand dune field at Samalayuca (Fig. 1) has been sporadically exploited for its predominantly siliceous content and used in the copper smelter at Cananea, Sonora (F. de la Fuente, pers. comm. 1995), and by the InterCeramic Company for the production of tile (Cardenas Vargas, 1994). This scenic dune field may be classified as a national park by the Mexican Government and used for recreational purposes. At El Magistral south of General Trias, Chihuahua (Fig. 3), there is 25,000-30,000 mtpy production of silica sand from Las Vigas Formation of Early Cretaceous age. Some of this material is used in cement manufacture. Limited shipments of silver-bearing, siliceous tailings have been shipped from the Cusiuhiriachic district as flux at the ASARCO smelter in El Paso.

### Abrasive and/or filtration materials

#### Garnet

Andradite to grossular garnet may be recovered by remediation of the Hanover mill tailings, east of Silver City, New Mexico (Fig. 1). About 160,000 mt of tailings is present, of which the garnet content varies from 20 to 40 wt.% in different size fractions (Cetin et al., 1995; editors' note: *see* Cetin et al., this volume). Possible uses as abrasive or filtration media are envisioned. Tailings were derived from several varieties of skarn-type mineral deposits, originally mined for their metal content, primarily iron, zinc, cadmium, and lead. The host rocks are upper Paleozoic carbonates, that have been intruded by Cretaceous- to Oligocene-age granitoids (Lueth, 1995; editors' note: *see* Lueth, this volume). The largest deposits are associated with copper mineralization at the Chino and Cobre mines. The second largest deposit is associated with lead-zinc skarns, mainly in the Hanover—Fierro district, Grant County, New Mexico, whereas the smallest deposits are iron skarns located at in the Orogrande district, Otero County, New Mexico.

#### Zeolites

A portion of the Tertiary tuff of Little Mineral Creek, located in the southern part of the Winston graben, 6 km south of Winston, New Mexico, is mined for zeolites by the St. Cloud Mining Company. The ore is crushed, dried and screened to produce various product grades. Production was 20,000 mt in 1994 and is expected to reach 27,000 mt in 1995 (Chavez, 1995; editors' note: *see* White et al., this volume). About 60% is used in cat litter (Austin and Mojtabai, 1995; editors' note: *see* Austin and Mojtabai, this volume), 20% in animal feed, and 20% in environmental and water filtration.

In the ore, clinoptilolite is the most abundant mineral (50%) with minor to trace amounts of quartz and sanidine. The pre-alteration host rock was probably a Miocene(?) rhyolite airfall-tuff. Interbedded with the zeolite ore are laterally discontinuous, channel-fill deposits of varying composition volcanic materials (Chavez et al., 1995; editors' note: *see* White et al., this volume).

## Miscellaneous

### Agate

Four well-known agate localities are present in the Sierra del Gallego in north-central Chihuahua (Fig. 3, Table 1). Virtually all agate in this area occurs as amygdulifillings in the thin flows of the Rancho El Agate andesite of Late Eocene age (Keller, 1977). These agates are highly prized because of their vivid colors and exceedingly fine banding. Much of the resistant agate is loose on the surface as the enclosing andesite easily erodes.

### Beryllium

Beryllium ore is hosted by fluor spar deposits at the Round Top rhyolite laccolith near Sierra Blanca, west Texas (Fig. 2). The fluor spar deposits occur in Cretaceous limestone where intruded by rhyolite. A total of 771,000 mt averaging 1.5 wt.% BeO has been identified (Rubin et al., 1990). Bertrandite and phenacite are the most common minerals along the limestone-rhyolite contact.

### Geodes

Las Choyas geodes are actively mined at a locality that has difficult access by dirt roads in the rainy season (Fig. 3). The geodes occur as lithophysal cavity fillings in an intensely altered basal vitrophre of an ash-flow tuff of Eocene age (Keller, 1977). The altered glass weathers easily, freeing the geodes. Small underground mining operations began in 1962.

### Ochre

Los Lamentos ochre mine was well-known for its former production of lead and silver. The mine closed in 1930, but subsequently zinc oxides and hematite have been mined on a small scale. Wulfenite crystals from this locality are on display in collections world-wide (Alvarez and Giles, 1986).

### Mexican Onyx

An onyx marble deposit of commercial grade is located in the Tres Hermanas Mountains (Fig. 1) about 6 km west-northwest of Columbus, Luna County, New Mexico (Grisold, 1961). Cutting and polishing was done in nearby Columbus, and the finished stone was used for interior trim.

### Smelter Slag

There is a limited use for black smelter slag, produced from the El Paso smelter, as landscaping or ballast. The railroad bed of the former El Paso and Southwestern Railroad (Clark, 1992), which linked El Paso westward to Douglas, Arizona, and beyond, was constructed with waste from border smelters.

### Trinitite

For the sake of completeness, brief mention is made here of the Trinity Site (Szasz, 1984), locale of the first atomic bomb explosion on July 16, 1945. The site is located within White Sands Missile Range, established in 1942. The heat of the blast fused the desert sand to artificial glass known as Trinitite. The Trinity site is open to visitors twice a year.

### Turquoise

The most productive district in New Mexico is in the Burro Mountains (Northrap et al., 1973). Set in jewelry, this gemstone is popular throughout the Southwest.

## Restricted occurrences

### White Sands National Monument

The gypsum dunes of the National Monument are in the Tularosa Basin, a structural and topographic low between the San Andres Mountains to the west and the Sacramento Mountains to the east. Although the Rio Grande may once have flowed through the southern part of this basin, subsequent uplift of the basin margins excluded the river. Internal drainage was created, and during the Pleistocene, when rainfall was more plentiful than today, Lake Otero formed in the western part of the basin at the southwestern tip of the present dune field. Subsequently Lake Otero evaporated and today is only a few centimeters deep in the rainy season. What took its place is Alkali Flat, part of the northern Chihuahuan Desert climatic zone. Gypsum was initially brought into the basin by streams draining Paleozoic formations that contain this mineral, the most notable being the Yeso Formation of Lower Permian age (Fig. 4). In the San Andres Mountains, northwest of the monument, this formation is 480 m thick, of which 195 m are rich in gypsum (Houck and Collier, 1994). Precipitation of calcium sulfate as gypsum and selenite under the prevailing arid conditions was enhanced by drying up of Lake Otero. Strong southwesterly winds have piled the gypsum into dunes of the White Sands National Monument, although less than half of the total accumulation of gypsum dunes falls within the monument. The remainder is located in White Sands Missile Range. The total size of the gypsum dune field is 720 km<sup>2</sup> and contains 94.0-99.7 wt.% pure gypsum. The national monument was created by President Herbert Hoover in 1933, and exploitation is prohibited. Scientific and recreational pursuits are the major attractions of this area.

### Samalayuca dune field

Los Medanos de Samalayuca, approximately 50 km south of El Paso—Ciudad Juarez, is a dune field of about 145 km<sup>2</sup> extent (Fig. 1), with most of the sand occurring between 1,275 and 1,450 m above sea level. A large part of the sand dunes are in a desert basin between the Sierra de Presidio on the northeast and the Sierra de Samalayuca to the southwest.

The sand, composed primarily of quartz, was probably first deposited by the ancestral Rio Grande in a large pluvial lake during Pleistocene time. As the Rio Grande altered its course, the lake dried up, pluvial conditions ceased, and the present-day Bolson de los Muertos formed. West to southwest winds transported the sand towards the east and formed the dunes. The general shape and patterns of the dunes are unconventional (Schmidt and Marston, 1983); however, an aklé pattern, with sinuous dune ridges oriented transverse to the prevailing wind flow, is recognized.

### Carlsbad Caverns

These world-famous caverns are located in the Guadalupe Mountains of southeastern New Mexico 32 km southwest of Carlsbad (Fig. 2). The caverns are in the basin margin—Capitan reef area with Delaware Basin units to the southeast and the shelf area sediments to the northwest. All lithologic units are of Permian age (Fig. 4). In the reef area, the Capitan Limestone is subdivided into a massive (reef) member and a breccia (forereef) member that interfinger both vertically and laterally. As the reef grew upward, reef debris slumped into the basin, and later reef organisms grew over the debris toward the basin.

The caves of the Guadalupe Mountains formed by a combination of deep phreatic and water table hydrologic controls. The sequence of events leading to cavern formation has been documented in detail by Hill (1987), only a small part of which is reproduced here. Two periods of solution of reef limestone may have preceded the development of large caves in Plio-Pleistocene time and the main uplift of the Guadalupe Mountains (1-3 Ma). Tilting of the adjacent Bell Canyon Formation allowed hydrocarbon migration updip, and H<sub>2</sub>S was produced by reaction with the Castile anhydrite to form hydrogen sulfide, carbon dioxide, and secondary limestone of the Castiles buttes (Kirkland and Evans, 1976). Enrichment of <sup>32</sup>S in H<sub>2</sub>S and sulfur deposits was caused by bacteria-induced fractionation as previously indicated. Sulfuric acid formed where oxygen-rich meteoric water mixed with H<sub>2</sub>S gas and dissolved out the large cave passages in the Guadalupe Mountains. Thus, the traditionally held view of solution by carbonic acid is not believed to be responsible for cavern development.

Speleothems include stalagmites, stalagmites, columns, and domes. They began to decorate caves as soon as they became air-filled from about 600,000+ to 200,000 years before present (ybp) to the present. Several other deposits including spar (calcite), clay, gravel, chert, gypsum, sulfur, and guano from bats that entered the caves not less than 32,000 ybp. Animal bones date from approximately 112,000 ybp after entrances to the caverns became open. Since the 1920s people have been touring the Caverns. In 1923, President Coolidge proclaimed the area a national monument, and in 1930 it became a national park.

#### Acknowledgments

Sincere thanks are expressed to George S. Austin for his help and patience as the paper developed. Fernando E. de la Fuente L. and Robert H. Schmidt also helped by way of data input and critical reading, respectively. Palmira Hart prepared the text, and Rebecca Titus, Kathryn Glesener, and David McCraw made the line drawings.

#### References

- Albritton, C. C., Jr., and Smith, J. F., Jr., 1965, Geology of the Sierra Blanca area, Hudspeth County, Texas: U.S. Geological Survey, Professional Paper 479, 131 pp.
- Amsbury, D. L., 1958, Geology of the Pinto Canyon area, Presidio County, Texas: University of Texas (Austin), Bureau of Economic Geology, Geologic Quadrangle Map no. 22, scale 1:63,360.
- Anthony, E. Y., and Poths, J., 1992, <sup>3</sup>He surface exposure dating and its implications for magma evolution in the Potrillo volcano field, Rio Grande rift, New Mexico, U.S.A.: *Geochemica et Cosmochimica Acta*, v. 56, p. 4105-4108.
- Alvarez, A., and Giles, D. A., 1986, Los Lamentos lead-silver mine, Chihuahua: Society of Economic Geologists, Guidebook, pp. 305-310.
- Austin, G. S., and Barker, J. M., 1990, Economic geology of the Carlsbad potash district: Society of Economic Geologists, Guidebook Series, v. 8, pp. 97-114.
- Austin, G. S., and Goolsby, M. R., 1995, Modern New Mexico adobe: A response to some environmental concerns: 31st Forum on the Geology of Industrial Minerals, Program with Abstracts, p. 10.
- Austin, G. S., and Mojtabai, C., 1995, Cat litter: A growing market for industrial minerals: 31st Forum on the Geology of Industrial Minerals, Program with Abstracts, pp. 8-9.
- Barker, J. M., and Austin, G. S., 1995, Overview of the Carlsbad potash district, New Mexico: 31st Forum on the Geology of Industrial Minerals, Program with Abstracts, pp. 11-12.
- Barker, P. W., 1977, Northern Trans-Pecos magmatic province: Introduction and comparison with the Kenya rift: *Geological Society of America Bulletin*, v. 88, pp. 1421-1427.
- Barnes, V. E., 1975, Geologic atlas of Texas, Van Horn-El Paso sheet: University of Texas (Austin), Bureau of Economic Geology, Scale 1:250,000.
- Borns, D. J., 1987, Structural development of evaporites in the northern Delaware Basin: *El Paso Geological Society, Guidebook 18*, pp. 80-97.
- Bourbon, W. B., 1981, The origin and occurrences of talc in the Allamore district, Culberson and Hudspeth Counties, Texas: Unpublished MS thesis, West Texas State Univ., 65 pp.
- Bourbon, W. B., 1982, The origin of talc in the Allamore district, Texas; *in* *Industrial Minerals and Rocks of the Southwest: New Mexico Bureau of Mines and Mineral Resources, Circular 182*, pp. 77-84.
- Boyd, F. M., and Kreidler, C. W., 1987, Hydrology of a gypsum playa, northern Salt Basin, Texas: *El Paso Geological Society, Guidebook 18*, pp. 170-183.
- Cardenas Vargas, J. (coordinator), 1994, *Monografía geológico-minera del Estado de Chihuahua: Consejo de Recursos Minerales, Publicación M14e*, 297 pp. (published in Spanish and English; includes map with scale of 1:500,000).
- Cetin, U., Walder, I. F., Lueth, V. W., and Gundiler, I. H., 1995, Recovery of garnet from Hanover mill tailings, Grant County, New Mexico, U.S.A.: 31st Forum on the Geology of Industrial Minerals, Program with Abstracts, pp. 16-17.
- Chavez, W. X., Jr., White, J. L., and Barker, J. M., 1995, Economic geology of St. Cloud Mining's Cuchillo Negro zeolite deposit near Winston, Sierra County, New Mexico: 31st Forum on the Geology of Industrial Minerals, Program with Abstracts, pp. 17-18.
- Clark, K. F., 1984, Geological report on Los Charcos gypsum, Villa Ahumada Municipality, Chihuahua: [Unpublished report], 34 pp.
- Clark, K. F., 1995a, Norfluor S.A. de C.V. HF acid plant, Cementos de Chihuahua S.A. de C.V. Cement plant and mines: 31st Forum on the Geology of Industrial Minerals, Excursion No. 2 Guidebook, 14 pp.
- Clark, K. F., 1995b, American Eagle Brick Company plant and mine, Fort Selden, White Sands National Monument, International Space Hall of Fame, Orogrande mining district: 31st Forum on the Geology of Industrial Minerals, Excursion No. 3 Guidebook, 12 pp.
- Clark, K. F., 1995c, Freeport McMoran Culberson mine, IMC Fertilizer Inc. potash mine, Carlsbad Caverns National Park: 31st Forum on the Geology of Industrial Minerals, Excursion No. 4 Guidebook, 39 pp.
- Clark, K. F., 1995d, Milwhite Inc. Tumbledown Mountain Talc mine; Pioneer (Suzrite) Inc., Talc plant; and Texas Architectural Aggregates, Marble Canyon mine: 31st Forum on the Geology of Industrial Minerals, Excursion No. 5 Guidebook, 28 pp.
- Clark, K. F., 1995e, Road log from El Paso to Chihuahua, and Train log from Chihuahua to Copper Canyon, Mexico: 31st Forum on the Geology of Industrial Minerals, Excursion No. 6 Guidebook, 40 pp.
- Clark, K. F., and Holguin L. J., 1995, Road log from El Paso to Interceramic plant and clay deposit: 31st Forum on the Geology of Industrial Minerals, Excursion No. 1 Guidebook, 29 pp.
- Clark, K. F., and Melendez, L. R., 1989, The Probesa concrete block operation: [Unpublished report], 35 pp.
- Clark, P. M., 1992, El Paso and Southwestern Railroad: The Copper Road: *El Paso Geological Society, Guidebook 24*, pp. 471-476.
- Cofer, R. S., 1980, Geology of the Shely Cauldron Complex, Pinto Canyon area, Presidio County, Texas: Unpublished MS thesis, University of Texas (El Paso), 137 pp.
- Crawford, J. E., 1990, Geology and Frasch mining operations of Culberson sulfur mine, Culberson County, west Texas: *Society of Economic Geologists, Guidebook Series*, v. 8, pp. 141-162.

- Cudahy, G. F., 1995, Brick tunnel-kiln thermal-energy inputs: 31st Forum on the Geology of Industrial Minerals, Abstracts with Programs, p. 22.
- Dane, C. H., and Bachman, G. O., 1965, Geologic map of New Mexico: U.S. Geological Survey, scale 1:500,000.
- Davis, R. E., and Greenspoon, G. N., 1946, Fluorspar and cryolite; *in* Minerals Yearbook: U.S. Bureau of Mines, Minerals Yearbook, 1944, pp. 1399-1422.
- Deen, R. D., 1976, The mineralization in the Precambrian rocks of the northern Franklin Mountains: El Paso Geological Society, Guidebook 8, pp. 183-188.
- de la Fuente L., F. E., 1983, The mineral industry of the State of Chihuahua: El Paso Geological Society, Guidebook 15, pp. 295-302.
- DiPeso, C. C. Renaldo, J. B., and Fenner, G. J., 1974, Casas Grandes, a fallen trading center of the Gran Chichimec: The Amerind Foundation Inc., Dragoon, Arizona, 8 volumes, 3,563 pp.
- Edwards, G., 1980, Tumbledown Mountain deposit, Allamoore district, Culberson County, Texas: New Mexico Geological Society, Guidebook 31, pp. 245-250.
- Edwards, G., 1984, Petrography and geochemistry of the Allamoore Formation, Culberson and Hudspeth Counties, Texas: Unpublished PhD dissertation, University of Texas (El Paso), 287 pp.
- Evans, G. L., 1943, Fluorspar deposits in the Eagle Mountains of Hudspeth County, Texas: University of Texas (Austin), Bureau of Economic Geology, Mineral Resource Circular 26, 10 pp.
- Evans, G. L., 1946, Barite deposits of Texas: University of Texas (Austin), Bureau Economic Geology, Publication no. 4301, pp. 105-111.
- Filsinger, B., 1988, Geology and genesis of the Palm Park and Horseshoe barite deposits, southern Caballo Mountains, Doña Ana County, New Mexico: Unpublished MS thesis, University of Texas (El Paso), 250 pp.
- Flawn, P. T., 1951, Pegmatites of the Van Horn Mountains, Texas: University of Texas (Austin), Bureau of Economic Geology, Report of Investigation 9, 30 pp.
- Flege, R. F., 1959, Geology of the Lordsburg quadrangle, Hidalgo County, New Mexico: New Mexico Bureau of Mines and Mineral Resources, Bulletin 62, 36 pp.
- Flores, C. L., 1956, Estudio de las salinas de Samalayuca, Distrito Bravos, Chihuahua: [Unpublished report], 40 pp.
- Garcia, G., 1995, Economic exploration of the Cretaceous Lagrimas Formation for the production of Portland Cement, Ciudad Juarez, Chihuahua, Mexico: 31st Forum on the Geology of Industrial Minerals, Program with Abstracts, p. 25.
- Garcia G., L., 1974, Informe preliminar sobre las salinas de Samalayuca, Chihuahua: [Unpublished report], 9 pp.
- Garner, L. E., St. Clair, A. E., and Evans, T. J., 1979, Mineral Resources Map of Texas (reprinted 1987): University of Texas (Austin), Bureau of Economic Geology, scale 1:1,000,000.
- Gerald, R. E., 1983, Geological resources utilized by the prehistoric Society of Casas Grandes, northwestern Chihuahua: El Paso Geological Society, Guidebook 15, pp. 425-428.
- Griswold, G. B., 1961, Mineral deposits of Luna County, New Mexico: New Mexico Bureau of Mines and Mineral Resources, Bulletin 72, 157 pp.
- Handschy, J. W., and Dyer, R., 1987, Polyphase deformation in Sierra del Cuervo, Chihuahua, Mexico: Evidence for ancestral Rocky Mountains tectonics in the Ouachita foreland of northern Mexico: Geological Society of America Bulletin, v. 99, pp. 618-632.
- Hentz, T. F., 1990, Native sulfur deposits in the western Delaware Basin, Trans-Pecos Texas: Origin, distribution, and exploration strategy: Society of Economic Geologists Guidebook Series, v. 8, pp. 115-140.
- Hentz, T. F., and Henry, C. D., 1989, Evaporite-hosted native sulfur in Trans-Pecos Texas: Relation to late-phase Basin and Range deformation: Geology, v. 17, pp. 400-403.
- Hill, C. A., 1987, Geology of Carlsbad Cavern and other caves in the Guadalupe Mountains, New Mexico and Texas: New Mexico Bureau of Mines and Mineral Resources, Bulletin 117, 150 pp.
- Hills, J. M., McAnulty, W. N., Mussey, J., Cochran, D. E., and Dickerson, P. W., 1980, First day road log from Van Horn to Guadalupe Mountains, to the Duval Frasch sulfur operation in Culberson County to Seven Heart Gap and return to Van Horn: New Mexico Geological Society, Guidebook 31, pp. 1-18.
- Hoffer, J. M., 1969, Volcanic history of the Black Mountain-Santo Tomas basalts, Potrillo volcanics, Doña Ana County, New Mexico: New Mexico Geological Society, Guidebook 20, pp. 108-114.
- Houck, R., and Collier M., 1994, White Sands National Monument: Southwest Parks and Monuments Association, Tucson, Arizona, 64 pp.
- Industrial Minerals, 1995, Prices: Industrial Minerals, v. 333, pp. 82-83.
- Isik, I., 1993, White brick manufacture utilizing Kline Mountain, New Mexico clay: Unpublished PhD dissertation, University of Texas (El Paso), 231 pp.
- Isik, I., Clark, K. F., and Austin G. S., 1994, Geology and alteration of the Kline Mountain kaolin deposit, Sierra County, New Mexico: New Mexico Geological Society, Guidebook 45, pp. 311-314.
- Keller, P. C., 1977, Geology of the Sierra del Gallego area, Chihuahua, Mexico: Unpublished PhD dissertation, University of Texas (Austin), 124 pp.
- Kelley, V. C., 1982, Southeast New Mexico stratigraphic column; *in* Geologic highway map of New Mexico: New Mexico Geological Society, scale 1:1,000,000.
- King, P. B., 1980, Geology of Tumbledown Mountain: New Mexico Geological Society, Guidebook 31, pp. 59-62.
- King, P. B., and Flawn, P. T., 1953, Geology and mineral deposits of the Precambrian rocks of the Van Horn area, Texas: University of Texas, Publ. 5301, 248 pp.
- Kirkland, D. W., and Anderson, R. Y., 1970, Microfolding in the Castille and Todilto evaporites, Texas and New Mexico: Geological Society of America Bulletin, v. 81, pp. 3259-3282.
- Kirkland, D. W., and Evans, R., 1976, Origin of limestone buttes, Gypsum Plain, Culberson County, Texas: American Association of Petroleum Geologists Bulletin, v. 60, pp. 2005-2018.
- Kyle, J. R., 1990, Barite deposits of the Delaware Basin: Society of Economic Geologists, Guidebook Series, v. 8, pp. 163-180.
- Kyle, J. R., and Clark, K. F., 1990, Geology of the Allamoore talc district, west Texas: Society of Economic Geologists, Guidebook Series, v. 8, pp. 181-190.
- Lesure, F. G., 1965, Pegmatite minerals; *in* Mineral and water resources of New Mexico: New Mexico Bureau of Mines and Mineral Resources, Bulletin 87, pp. 278-290.
- Lovejoy, E. M. P., 1976, Geology of Cerro de Cristo Rey uplift, Chihuahua and New Mexico: New Mexico Bureau of Mines and Mineral Resources, Memoir 31, 84 pp.
- Lowenstein, T. K., 1988, Origin of depositional cycles in the Permian "saline giant": The Salado (McNutt zone) evaporites of New Mexico and Texas: Geological Society of America Bulletin, v. 100, pp. 592-608.
- Lueth, V. W., 1995, Garnet resource potential in southern New Mexico: 31st Forum on the Geology of Industrial Minerals, Program with Abstracts, pp. 39-41.
- McAnulty, W. N., 1967, Fluorspar in Brewster County, Texas: University of Texas (Austin), Bureau of Economic Geology, Circular 67-2, 16 p.
- McAnulty, W. N., 1980, Barite deposits at Seven Heart Gap, Apache Mountains, Culberson County, Texas: New Mexico Geological Society, Guidebook 31, pp. 259-261.
- McAnulty, W. N., and Hoffer, J. M., 1980a, Second day road log from Van Horn to Tumbledown Mountain, Hazel mine, Southern Wylie Mountains and return to Van Horn: New Mexico Geological Society, Guidebook 31, pp. 19-25.
- McAnulty, W. N., and Hoffer, J. M., 1980b, Third day road log from Van Horn to Allamoore to Eagle Mountains to Quitman Mountains: New Mexico Geological Society, Guidebook 31, pp. 27-40.



- McLemore, V. T., and Guilinger, J. R., 1993, Geology and mineral resources of the Cornudas Mountain, Otero County, New Mexico and Hudspeth County, Texas: New Mexico Geological Society, Guidebook 44, pp. 145-153.
- McLemore, V. T., Lueth, V. W., and Guilinger, J. R., 1995, Geology, mineral resources, and marketing of the Wind Mountain nepheline syenite porphyry, Cornudas Mountains, New Mexico and Texas: 31st Forum on the Geology of Industrial Minerals, Program with Abstracts, pp. 42-43.
- Mendoza, M., 1995, U.S. scientists building better kilns in Mexico: El Paso Inc., December 3, p. 3.
- Murray, D. L., 1978, Barite deposits in the Seven Heart Gap Area, Culberson County, Texas: Unpublished MS thesis, University of Texas (El Paso), 65 pp.
- Newman, T. E., 1995, Brucite deposit in Marble Canyon, Culberson County, Texas: 31st Forum on the Geology of Industrial Minerals, Program with Abstracts, p. 43.
- Northrup, S. A., Newman, R. L., and Snow, R. H., 1973, Turquoise: El Placio, v. 79, no. 1, pp. 3-51.
- Ntsimanyana, M., 1990, Mineralogy and exploitation of the Anapra and Mesilla Valley formations for the production of brick and tile, Anapra, Doña Ana, New Mexico: Unpublished MS thesis, University of Texas (El Paso), 186 pp.
- Rubin, J. N., Price, J. G., Henry, C. D., and Kyle, J. R., 1990, Geology of the beryllium-Rare earth element deposits at Sierra Blanca, West Texas: Society of Economic Geologists, Guidebook Series, v. 8, pp. 191-203.
- Ruckmick, J. C., Wimberly, B. H., and Edwards, A. F., 1979, Classification and genesis of biogenetic sulfur deposits: Economic Geology, v. 74, pp. 469-474.
- Rudnick, R. L., 1983, Geochemistry and tectonic affinities of a Proterozoic bimodal igneous suite, west Texas: Geology, v. 11, pp. 352-355.
- Schmidt, R. H., and Marston, R. A., 1983, The Samalayuca dune field: El Paso Geological Society, Guidebook 15, pp. 417-424.
- Seager, W. R., 1982, South-central New Mexico stratigraphic column; *in* Geologic highway map of New Mexico: New Mexico Geological Society, scale 1:1,000,000.
- Searls, J. P., 1994, Potash; *in* Mineral commodity summaries 1994: U.S. Bureau of Mines, pp. 132-133.
- Skeats, E. M., Smith, A. E., and Phillips, W. B., 1902, Sulfur, oil, and quicksilver in Trans-Pecos Texas: University of Texas, Mineral Survey Bulletin 2, 43 pp.
- Smith, A. R., 1978, Sulfur deposits in Ochoan rocks of southeast New Mexico and west Texas: New Mexico Bureau of Mines and Mineral Resources, Circular 159, pp. 71-77.
- Sociedad Geológica Mexicana, 1985, Plano geológico minero, Chihuahua: Delegación Chihuahua, escala 1:500,000
- Soegaard, K., and Callahan, D. M., 1994, Late-middle Proterozoic Hazel Formation near Van Horn, Trans-Pecos Texas: Evidence for transgressive deformation in Grenvillian basement: Geological Society of America Bulletin, v. 106, pp. 413-423.
- Szasz, F. M., 1994, The day the sun rose twice: University of New Mexico Press, Albuquerque, 233 pp.
- Strain, W. S., 1966, Blancan mammalian found and Pleistocene formations of Hudspeth County, Texas: Texas Memorial Museum, Bulletin 10, 55 pp.
- Sullivan, D. E., and Michael, N., 1986, Potash availability-Market economic countries-A minerals availability appraisal: U.S. Bureau of Mines, Information Circular 9084, 32 pp.
- Van Alstine, R. E., 1965, Fluorspar; *in* Mineral and water resources of New Mexico: New Mexico Bureau of Mines and Mineral Resources, Bulletin 87, pp. 260-267.
- Virta, R. L., 1988, Talc and pyrophyllite; *in* Minerals Yearbook: U.S. Bureau of Mines, 7 pp. (preprint).
- Walls, J. M., 1985, Overall view of Carlsbad potash: [Unpublished report], New Mexico Bureau of Mines and Mineral Resources, 9 pp.
- Weber, R. H., 1965, Lightweight aggregates; *in* Mineral and water resources of New Mexico: New Mexico Bureau of Mines and Mineral Resources, Bulletin 87, pp. 332-344.
- Williams, F. E., 1965, Barite; *in* Mineral and water resources of New Mexico: New Mexico Bureau of Mines and Mineral Resources, Bulletin 87, pp. 257-261.
- Williams-Stroud, S., 1995, Potash; *in* Mineral and energy resources of the Roswell resource area, east-central New Mexico: U.S. Geological Survey, Bulletin 2063, pp. 54-56.
- Wood, J. W., 1968, Geology of Apache Mountains, Trans-Pecos Texas: University of Texas (Austin), Bureau of Economic Geology, Geologic Quadrangle Map 35, 35 pp., scale 1:63,360.



# Overview of celestite deposits of south-central Coahuila, Mexico—Geology and exploitation

Abelardo Rodriguez Garza<sup>1</sup> and W. Noel McAnulty, Jr.<sup>2</sup>

<sup>1</sup>*Compania Minera La Roja, 301 F Paseo del la Rosita, Campestre la Rosita, Torreon, Coahuila 27250, Mexico;*  
<sup>2</sup>*Consulting Geologist, 6328 Monarch Drive, El Paso, Texas 79912, USA*

**Abstract**—Mexico is the world's largest producer of celestite ores, and almost all Mexican celestite production is from south-central Coahuila between Torreon and Saltillo. Coahuila celestite is mined from manto deposits in carbonate rocks and gypsum beds of the Acatita Formation deposited over the Coahuila Platform in Early Cretaceous time. Principal producing areas are Sierra La Paila, Rancho Cuates de Australia, Sierra San Lorenzo, and Sierra Tlahualilo.

The Mina La Ilusion deposit, typical of Coahuila celestite deposits, is a nearly horizontal replacement manto averaging 1.2 m thickness in nearly flat-lying, thick-bedded algal limestones. La Ilusion manto is 450 m in outcrop and has been mined 250 m downdip from its surface exposure. Limits of the manto have not been reached. The manto consists of 85-95% coarse-grained celestite, the remainder being mostly dark-colored limestone and coarsely crystalline calcite plus less than 1% barite.

Coahuila celestite manto deposits are mined via adit entry, underground by room-and-pillar methods. Some ores are shipped mine-run to sulfate-conversion plants; most ores are concentrated by jigs or shaking tables to remove limestone impurities. Celestite ores and concentrates are shipped in bulk to sulfate conversion plants in Mexico or exported.

## Una perspectiva general de los yacimientos de celestita en el centro sur de Coahuila, México-su geología y explotación

**Resumen**—México es el productor mundial más grande de celestita. Casi toda la producción proviene del centro sur del estado de Coahuila entre Torreón y Saltillo. Se trata de yacimientos tipo manto en estratos de carbonatos y yeso de la Formación Acatita depositados en la Plataforma de Coahuila durante el Cretácico inferior. Areas principales de producción son Sierra La Paila, Rancho Cuates de Australia, Sierra San Lorenzo y Sierra Tlahualilo.

Mina La Ilusión es típica de los yacimientos de Coahuila. Es un depósito metasomático de manto casi horizontal con un espesor medio de 1.2 metros de mena. Está compuesto entre estratos planos y gruesos de caliza alga. El manto de La Ilusión aflora sobre 450 m y se ha minado 250 m en dirección del buzamiento. Aun no se ha llegado a los bordes del manto. El manto consiste de 85-95% de celestita de grano grueso, el resto es mayormente caliza oscura y calcita cristalina de grano grueso y barita que no supera el 1%.

Estos depósitos de manto se explotan mediante socavones usando métodos subterráneos de cuarto-y-columna (*room-and-pillar*). Parte de la mena es transportada, tal como sale de la mina, a plantas de conversión de sulfato. Pero la mayor parte es triturada y concentrada por tamizado (*jig*) o mesa vibratoria para separar la caliza del sulfato. Mena y concentrado son trasportados en bulto a plantas de conversión de sulfato en Mexico, o exportados.

### Introduction

Mexico is the world's largest producer of celestite ores, which are the principal source of strontium. Mexico's rise to become the world's top celestite producer has been rapid; production increased from only a few thousand metric tons (mt) of crude ore shipped to distant processing plants in 1970 to about 150,000 mt per year today, most of which are processed in concentrating mills and sulfate conversion plants in northern Mexico. Almost all Mexican celestite production is from south-central Coahuila, mostly from the large, sparsely populated region between Torreon and Saltillo (Fig. 1). Little information has been published about the Coahuila celestite deposits because many of them have been discovered only recently and because competition for reserves and markets has caused reluctance to release information.

Topographic and geologic maps of the celestite region published by the Mexican government predate the celestite boom, so few of the celestite mines or roads to the

presently active mines are shown on the maps. Most of the celestite mines are remote, well away from the main roads, and gates on many of the mine roads are locked, all factors which make it difficult to acquire even general information about the deposits. This paper is an overview of the geology of celestite deposits in south-central Coahuila, including a detailed description of the La Ilusion, one of the principal producing mines, and a brief summary of mining methods, transportation, and processing of celestite ores.

### Mining history

The first significant mining of celestite in the Coahuila area began during World War II when strontium demand surged for use in flares and tracer bullets. Small tonnages of celestite were mined using crude methods from deposits near railroads, especially near Bermejillo, Durango



FIGURE 1—Location map of Mexico showing the south-central Coahuila celestite area (shaded).

(Fig. 2), about 40 km northwest of Torreon; near Escalon, Chihuahua; and in Sierra de Paila and near Ramos Arizpe, Coahuila. The 1940s boom in strontium markets encouraged prospecting and led to the discovery of many celestite occurrences which were not exploited at that time. Specifications for celestite ores during the war years were lax, and ores with 85% or less celestite and several percent barite were shipped.

Celestite mining in the Coahuila area slowed considerably after the war, but in the mid-1960s the demand for strontium began a prolonged, gradual increase related to its use in television tube glass and magnetic ceramics, which still are the principal end uses of strontium. Celestite ores from the San Agustin mine were sold to two strontium processors in the United States from the late 1960s until about 1980, but limited access to markets kept production from other celestite mines low.

In the early 1980s Minera Valenciana purchased one of the U.S. strontium-conversion plants in the United States and relocated the facility to Gomez Palacio, Durango (the Torreon area), to process ores from its San Agustin mine. Demand for strontium continued to increase, and as Mexican producers of both crude ores and strontium carbonate demonstrated their ability to meet strict quality requirements, production of Mexican celestite expanded. From the late 1980s to the present, a boom in the Mexican celestite industry has been underway. New strontium sulfate conversion plants have been constructed in Monterrey and Reynosa, and concentrating plants have been constructed at Estacion Madero and Cerro Pajonal.

Several new mines have opened, and prospecting for new deposits continues.

#### Regional geology

Most of northern Coahuila and northeastern Chihuahua are underlain by complex terranes of Paleozoic age considered to be part of the North American craton that stood as an emergent highland at the end of the Paleozoic. During the Mesozoic, marine waters gradually covered these older cratonic rocks, depositing carbonate and clastic rocks totaling many hundreds of meters in thickness. Marine transgression from the south and southeast, which began in the late Jurassic, was related to opening of the Gulf of Mexico. In western Coahuila a large, northerly trending highland area, the Coahuila Peninsula, remained above the advancing sea during Late Jurassic and Early Cretaceous (Kellum et al., 1936). The peninsula was bounded to the east by the Sabinas Basin and to the west and south by deep waters of the Mexican Sea (Mar Mexican; Fig. 3). The highland peninsula was gradually covered by advancing seas through the Early Cretaceous, leaving only scattered islands of which Coahuila Island was by far the largest and the last to submerge.

Coahuila Island, or the Coahuila Platform from a sedimentological standpoint, submerged in the middle Cretaceous (late Aptian), depositing a relatively thin blanket of clastic sediments comprising the Las Uvas Formation (Fig. 3). At about the same time a large reef complex developed along the margins of the platform, the Viesca Formation of Garza (1973). As sea level gradu-

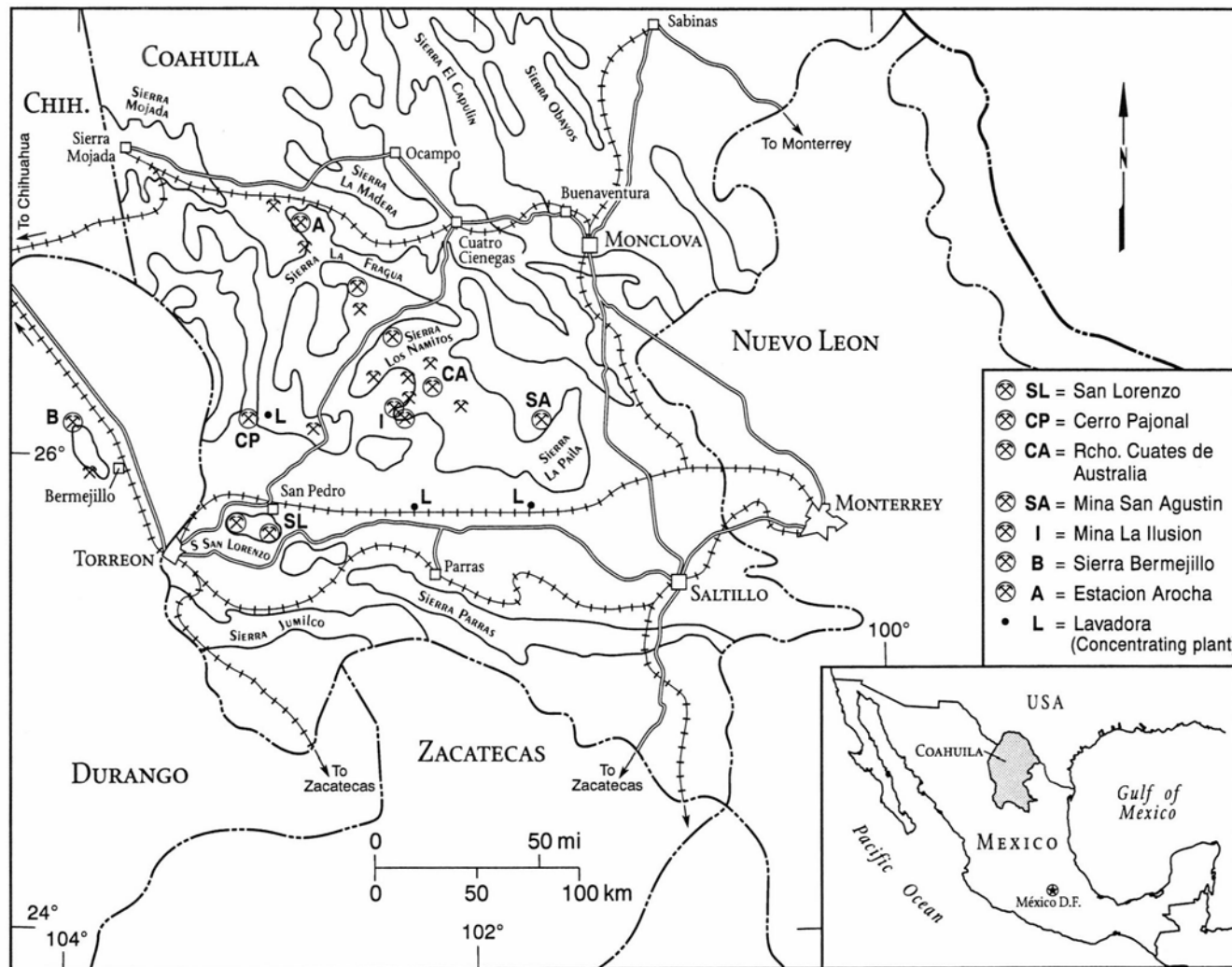

FIGURE 2—Location map of south-central Coahuila showing the principal celestite-producing areas and concentrating plants.

ally rose and the reefs grew, a large lagoon developed behind the reef, eventually covering all of the Coahuila Platform. A sequence of limestones, dolomitic limestones, and anhydrite (or gypsum), which comprises the

Acatita Formation, was deposited in the shallow lagoon during the middle Cretaceous (early to middle Albian). A gradual, steady rise of sea level led to a substantial accumulation of shallow-water sediments. Outcrops of

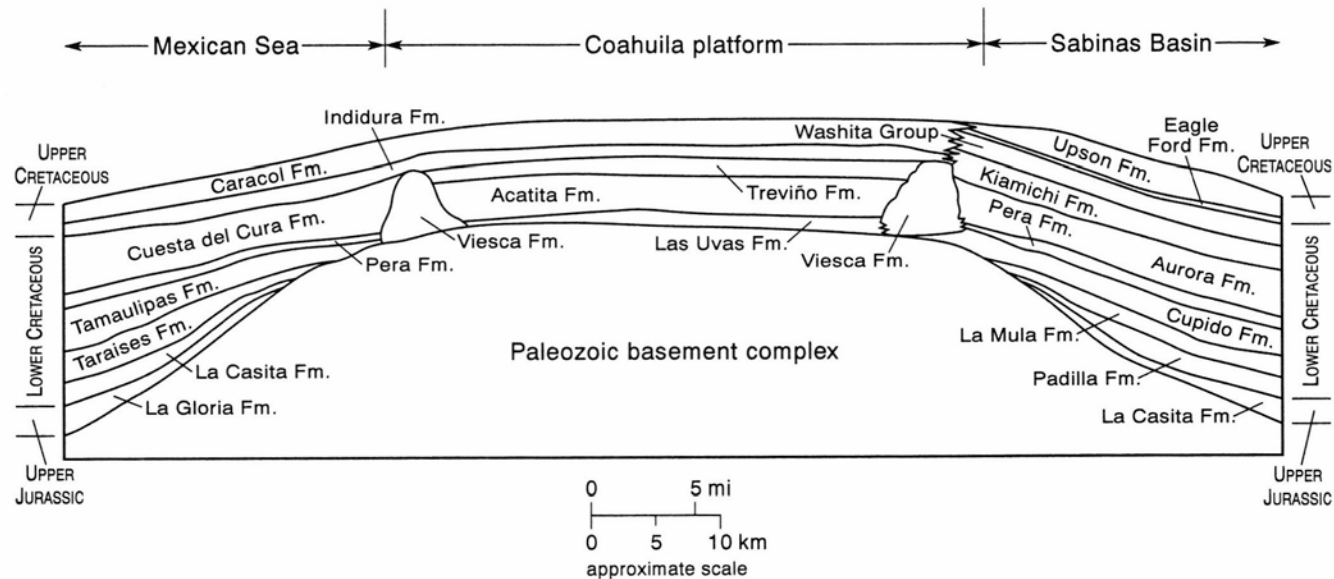

FIGURE 3—Diagrammatic cross section of the southern part of the Coahuila Platform showing relations of the Lower Cretaceous rocks.

the Acatita Formation are 300-400 m thick without the base of the formation exposed. Thickness of 800 m was reported for the formation from Pemex drilling (Equiluz and Campa, 1982, p. 11). Garza (1973) reported gypsum in the Acatita to be most common in areas of the platform where basement was topographically high, with dolomite interbedded with gypsum and limestone more common near the margins of the platform (Garza, 1973, p. 327).

The Aurora Formation is time-equivalent of the Acatita but is a pelagic-facies dark-colored lime-mud limestone deposited in comparatively deep water of the adjacent Sabinas Basin. Marine waters gradually became slightly deeper and more open over the Coahuila Platform, resulting in deposition of thick-bedded limestones of the Trevino Formation conformably over the Acatita Formation. Total thickness of 250 m is reported for the Trevino Formation. Garza (1973) described the Trevino as thick-to-massive beds of gray milliolid limestone with abundant fossil fragments and biostromes in scattered intervals. Some limestone beds in the lower part of the Trevino are dolomitized.

The Coahuila Platform remained submerged through the Late Cretaceous time, but the sedimentological regime was markedly different because of tectonic uplifts in western Mexico shedding increasing amounts of clastic sediments eastward and a slow regression of seas to the east. A thick sequence of argillaceous limestones comprises the Indidura Formation (Fig. 3), which is overlain by calcareous shales and sandstones of the Parras Formation and Difunta Group.

The Coahuila Platform was a buttress to compressional deformation during the Laramide orogeny at the end of the Cretaceous. Acatita Formation rocks near the margins of the platform were tightly folded in a few areas such as Sierra San Lorenzo, while rocks in the central part of the platform were only very gently, broadly folded with dips seldom exceeding 10-15°. Basinal rocks were thrust eastward over the platform. The thrust zone is structurally complex and poorly exposed, and details of the thrust geometry thus are only partially documented. Following the Laramide deformation, platform rocks were cut by widely spaced high-angle faults, most of them with small displacements. Interior-drainage basins accumulated thick sequences of continental sediments and widely scattered, small-volume basalt flows.

### Celestite deposits

Celestite deposits are known from a large area of the Coahuila Platform (Fig. 2). Mine symbols shown in Figure 2 represent either single producing mines or clusters of smaller prospects. For example, literally hundreds of small prospect workings are present in the Cuates de Australia area. The principal producing areas are Sierra de Paila (chiefly the San Agustin mine); a large area centered around Rancho Cuates de Australia in Sierra de Alamitos and Mesa de Barrancas that includes Mina La Ilusion; Sierra San Lorenzo; and the Cerro El Pajonal area of Sierra Tlahualilo. Deposits at Mina La Ilusion described below are considered typical of the Coahuila Platform celestite deposits.

### Mina La Ilusion

Mina La Ilusion is located 65 km north of Estacion Madero and 22 km south-southwest of Rancho Cuates de Australia at the southeast margin of Mesa Barrancas.

Topographic relief on the flank of the mesa in the mine area is approximately 120 m. Country rock is flat-lying to gently south-dipping limestones of the Acatita Formation. No igneous rocks are known in the vicinity. Celestite mantos at La Ilusion crop out midway up the mesa slopes and were found by surface prospecting.

The lithologic sequence at mina La Ilusion consists of carbonates (Fig. 4). At the base of the exposed section is a massive limestone unit approximately 20 m thick, probably an algal-bank deposit with very poorly developed stratification. Overlying this unit is a series of light gray, thick-bedded, sparry limestones and dolomitic limestones with scattered small, reddish chert nodules. Both the sparry and dolomitic limestones have a strong fetid smell when broken. Microfossils and fragments of larger fossils make up 40% or more of the rock fabric. Minor amounts of dolomitic limestones occur in the thicker-bedded units, but the top and bottom of thick-bedded sequence are limestone. Limestone is present immediately under the celestite manto. The main celestite manto, about 1 m thick, is overlain by 2 m of thick-bedded limestone. A dissolution zone 20-50 cm thick and characterized by subangular clasts of limestone in a porous, caliche-coated matrix is poorly exposed 2 m above the main celestite manto. Above the dissolution zone is a sequence of mostly thick-bedded, fetid, sparry limestone with narrow intervals of medium-bedded, very fossiliferous limestone and dolomitic limestone. A second celestite manto 30-50 cm thick is present in limestone approximately 8 m above the lower manto. Above the upper manto are more sparry limestones in thick-to-massive beds.

The lower celestite manto is being exploited at La Ilusion. It is well exposed for 450 m along strike in the immediate area of the mine workings and is traceable in poor exposures and widely separated prospect pits for 500 m to the northeast, generally following the topographic contour. The manto is exposed in mine workings for 250 m east and north from its surface exposure. Lim-

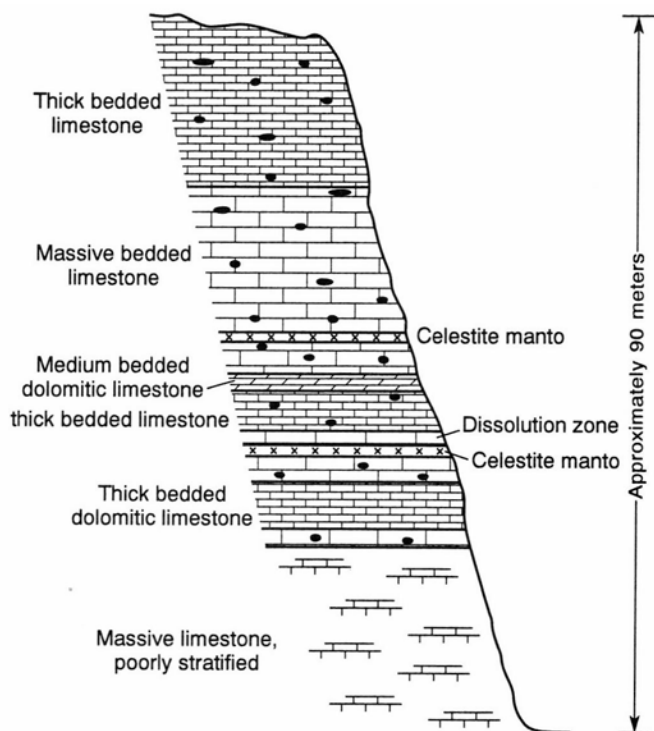

FIGURE 4—Generalized stratigraphic column, La Ilusion mine.

its of the manto have not been reached in mine workings. The manto is clearly strata-bound in the mine workings, maintaining a constant stratigraphic position throughout the area of its exposure. It is remarkably uniform in thickness, mineralogy, and texture. The manto thickness averages 1-1.2 m; only very localized areas of at most a few square meters have thicknesses of less than 1 m; other, larger areas reach thicknesses of 1.6 m. Both the footwall and the hanging wall of the manto show a sharp, planar contact with the enclosing limestone.

The manto consists of 85-95% celestite, with most of the remaining material being dark gray porous limestone, coarsely crystalline white calcite, and less than 1% barite. The celestite is relatively coarse-grained, its subhedral crystals ranging from 0.5 to 1.5 cm across. At the top and bottom the manto has a pronounced banded appearance and the grain sizes are locally smaller. Crystal-lined cavities in the manto range from 5 cm to 1 m across. Celestite crystals within the cavities are much larger than the normal grain size, reaching 10-15 cm across.

Only one fault is known to cut the La Ilusion manto. It trends N70°W and displaces the manto about 1.5 m down to the south. Adjacent to the fault is an irregular enriched zone of fine-grained barite and coarsely crystalline white calcite approximately 1 m wide. Very widely spaced, narrow, northeast-trending fracture zones are discernible, but do not appear to have displaced the manto. The upper celestite manto at La Ilusion has been neither mined nor explored by workings other than very shallow surficial pits, so few details about it are available. The upper manto is persistent in surface outcrops over essentially the same area as the lower manto.

#### Other celestite deposits of the Coahuila Platform

The Mina La Ilusion deposit is typical of celestite deposits on the Coahuila Platform. Most of the deposits are replacements in limestone and occur in stratigraphic sequences containing little if any gypsum. Exceptions are celestite deposits in Sierra San Lorenzo where mantos appear to replace gypsum beds (D. Croas, Chemical Products Corporation, pers. comm. 1995). Celestite deposits in the central part of the Coahuila Platform are flat-lying to very gently dipping, but in some places near the platform margins the mantos have been folded to steeply dipping or vertical attitudes, e.g. deposits in Sierra San Lorenzo and those south of Estacion Arocha (Fig. 2). Some miners on the Coahuila Platform refer to these steeply dipping deposits as "veins," but the celestite bodies are stratabound and appear to be mantos folded after their formation. Faulting of the mantos, especially of those near the center of the platform, is very minor, with fault displacements of only 1-2 m.

Thicknesses of most of the exploited manto deposits average slightly over 1 m. Manto thicknesses of up to 3 m are reported for some deposits north of Cuates de Australia (Fig. 2), but the thicker mantos tend to have more barite and calcite impurities (D. Croas, Chemical Products Corporation, pers. comm. 1995). Mines at Cerro Pajonal are exploiting high-purity celestite mantos averaging 1.5 m thickness. The same mantos near the surface where they were mined in previous years averaged only 80 cm. Grain size of celestite in the La Ilusion manto is larger than in other deposits. For example, celestite mantos at Cerro Pajonal are uniformly fine-grained (average grain size about 3 mm), distinctly banded, and without cavities containing larger crystals. Some celes

tite mantos contain several percent barite, and are not economical. Other mantos contain very little barite, many less than 2% barite. Calcite is a common contaminant of many celestite deposits, but can be removed by simple gravity methods.

Celestite does occur in veins that are discordant to bedding of the country rock on the Coahuila Platform, especially in the general vicinity of Mina San Agustin (Fig. 2) and on Mesa Albardienta. The veins are steeply dipping to vertical, from 50 cm to 2 m wide, and the celestite is mixed with relatively large volumes of barite (up to 10%), coarsely crystalline calcite, in most instances at least minor amounts of fluorite. Few of the known veins contain celestite pure enough to be economical. Some of the veins are being utilized as a source of white filler in paints.

#### Exploitation of celestite deposits

All celestite production in central Coahuila is from aditentry underground mines. In years past, mines were worked on a small scale in a rudimentary manner involving mostly hand labor. Celestite mining has become more systematic and mechanized in recent years. Mina La Ilusion is one of the more modern celestite mining operations in the Coahuila region.

The La Ilusion celestite manto is being mined by room-and-pillar methods. Haulage drifts spaced 100m apart are driven northeast into the manto with perpendicular drifts driven to the southeast across the manto and are extended as mining progresses. The haulage drifts are 2 m high by 3 m wide to accommodate 4.5 mt (5 st) capacity diesel, rubber-tired underground haul trucks and a 0.75 m<sup>3</sup> (1 yd<sup>3</sup>) scoop tram. Working stopes are maintained the height of the manto. Celestite ores are drilled using jackhammer and jackleg, and blasted, usually with little or no breakage of footwall or hanging wall limestones. Ores are hand-mucked and transported short distances by wheel barrow to loading points on the haulage drifts. There ore is picked up by scoop tram and moved short distances for transfer to underground trucks which haul it from the mine to outside loading bins. Pillars 1 m in diameter and 3 m apart are left in mined-out stopes, allowing recovery of 80-85% of the manto ores. Little selective mining is required because the grade and thickness of the manto are uniform. Some hand-sorting of ores in the stopes and at the loading bins is done to remove barren limestone inadvertently broken with the manto ores. La Ilusion ores are loaded from storage bins onto 20 mt capacity dump trucks or 10 mt capacity flat-bed trucks for transport over 65 km of privately maintained dirt roads to the railhead at Estacion Madero. Ores are stockpiled for processing at the concentrating plant. Other mines in the region also employ room-and-pillar stoping methods for gently dipping or flat-lying mantos, but mines of the independent producers still lack mechanized transport of ores from the stopes to the surface. Some celestite ores are shipped mine-run to sulfate-conversion plants.

All celestite concentrating plants in the Coahuila region are simple gravity concentrators. Crude ore is crushed using either jaw crushers or hammer mills, sized by screening and/or spiral classifiers, and fed to jigs or shaking tables. Celestite is upgraded by removal of calcite to yield product containing 95-97% celestite. At present gravity tails containing celestite and calcite are discarded. Barite cannot be separated from celestite by the employed simple gravity methods because of the small difference in specific gravities and intermixing of

**the** two minerals. Celestite concentrates are air-dried and stockpiled at the plant site.

Crude celestite ores and celestite concentrates are shipped in bulk to sulfate-conversion plants in Mexico and abroad. Most of the ores are shipped by rail, but some are trucked to the conversion plant at Gomez Palacio.

#### **Acknowledgments**

Sincere appreciation is extended to Ing. J. Abelardo Rodriguez and Leo Jackson of Compania Minera La Roja, and to Rosalio Lopez Orozco for permission to visit their celestite mining operations and for discussions of celestite mining in Coahuila. David Croas of Chemical Products Company provided helpful descriptions of several celestite deposits in the Coahuila region. Luis Grijalva kindly donated his time for drafting illustrations. Betsy

Julian and Claudio Bartolini of UTEP reviewed the manuscript and made many helpful suggestions. Muchas gracias to all these people.

#### **References**

- Eguiluz, S., y Campa, M. F., 1982, Problemas tectonicos del sector San Pedro del Gallo, en los estados de Chihuahua y Durango: Boletín, Asociación Mexicana de Geólogos Petroleros, v. 34, no. 2, pp. 5-41.
- Garza, G. R., 1973, Modelo sedimentario del Albiano—Cenomaniano en la porción sureste de la Plataforma de Coahuila: Asociación Mexicana de Geólogos Petroleros, Boletín, v. 25, no. 7-9, pp. 311-340.
- Kellum, L. B., Imlay, R. W., and Kane, W. G., 1936, Evolution of the Coahuila Peninsula, Mexico, Part I, Relation of structures, stratigraphy, and igneous activity to an early continental margin: Geological Society of America Bulletin, v.47, pp. 969-1008.

# Economic exploitation of the Cretaceous Lagrimas Formation for production of portland cement, Ciudad Juarez, Chihuahua, Mexico

Greg Garcia

*Department of Geological Sciences, University of Texas at El Paso, El Paso, Texas 79968, USA*

**Abstract**—Situating in the southeastern part of the Sierra de Juárez, the Cementos de Chihuahua, S.A. de C.V. plant quarries nearby Cretaceous limestone. Aptian-Albian (Lower Cretaceous) limestone, known locally as the Lagrimas Formation, has been quarried extensively since 1972 employing open pit (quarrying) methods. Through a rotary kiln process, the subsequent product is primarily portland cement. The average daily production is 400 metric tons (mt) of cement clinker, which produces 600 mt of cement with the addition of additives. Currently the portland cement production at the Sierra de Juárez plant is for domestic Mexican markets. However, with the pending completion of the much larger Samalayuca cement plant south of Ciudad Juárez, the market focus will be directed towards the United States.

## Explotación económica de la Formación Lágrimas del Cretácico para la producción de cemento Portland, Ciudad Juarez Chihuahua, Mexico

**Resumen**—En la parte sureste de la Sierra de Juárez, la compañía Cementos de Chihuahua S.A. de C.V. está explotando calizas Cretácicas. La caliza es del Aptiano/Albiano (Cretácico inferior), conocida localmente como la Formación Lágrimas y desde 1972 ha sido explotada extensamente a cielo abierto. Haciendo use de un horno rotatorio, el producto principal es cemento Portland. El promedio de producción diaria es de 400 toneladas métricas de *clinker*, el cual, con la adición de otros productos, rinde 600 toneladas de cemento. En la actualidad, la producción de cemento Portland en la planta de la Sierra de Juárez es para los mercados domésticos mexicanos. Sin embargo, con la próxima terminación de la planta de cemento mucho más grande de Samalayuca al sur de Ciudad Juárez, el mercado se enfocará a los Estados Unidos.

### Introduction

The Cementos de Chihuahua, S.A. de C.V. Juarez plant is located in the southeastern section of the Sierra de Juarez. Since 1972 the plant has supplied the cement needs of Ciudad Juarez, a city with a population of approximately 1.5 million and a vast manufacturing industrial base.

The Cretaceous limestone formations of the southeastern flank of the Sierra de Juarez have provided the bulk of the raw materials necessary for the production of port-land cement. Current production is approximately 160,000 mt of Type I portland cement. The production process utilizes a dry process of mixing the raw material, which is subsequently burned through a short-range/ length rotary kiln.

Construction on a new 800,000 mt annual-capacity plant located a few kilometers south of Ciudad Juarez is due for completion in the fall of 1995. The new \$150 million plant is on the western flank of the Sierra del Presidio near the small community of Samalayuca. The limestone supply will come from the same Chihuahua Group Cretaceous limestone unit found in the Sierra de Juarez. Production at this new plant will be primarily Type II cement of export quality.

There are numerous small-scale gravel and aggregate quarries in the area that produce construction material.

In addition, there are numerous pits where local prospectors dug for iron oxides.

### Stratigraphy

The rock formations of the Sierra de Juarez represent the northernmost large outcrop area of Cretaceous marine embayment deposits and the northernmost exposures of a fold and thrust belt (Fig. 1). The sierra is underlain by strongly folded and thrust-faulted Lower Cretaceous sedimentary rocks that have a northwest-trending structural grain (Cordoba, 1969; Drewes, 1992).

The geology of the Sierra de Juarez is characteristic of the Chihuahuan fold and thrust belt, a northwestern-trending zone more than 600 km long. The deformation of the sierra is probably of Paleocene or early Eocene age. Lower Cretaceous rocks are the youngest rocks known to be deformed (Drewes, 1992; Drewes and Dyer, 1993).

The Cretaceous sedimentary rocks in the sierra are largely or entirely of marine origin, consisting of a widespread Lower Cretaceous (Aptian—Albian) sequence of Cuchillo Formation through Finlay Limestone (Fig. 2). Overlying this dominantly carbonate sequence is the predominantly clastic sequence of the del Norte through the Boquillas Formations (Drewes, 1992). These clastic units are regionally restricted, ranging in age from uppermost

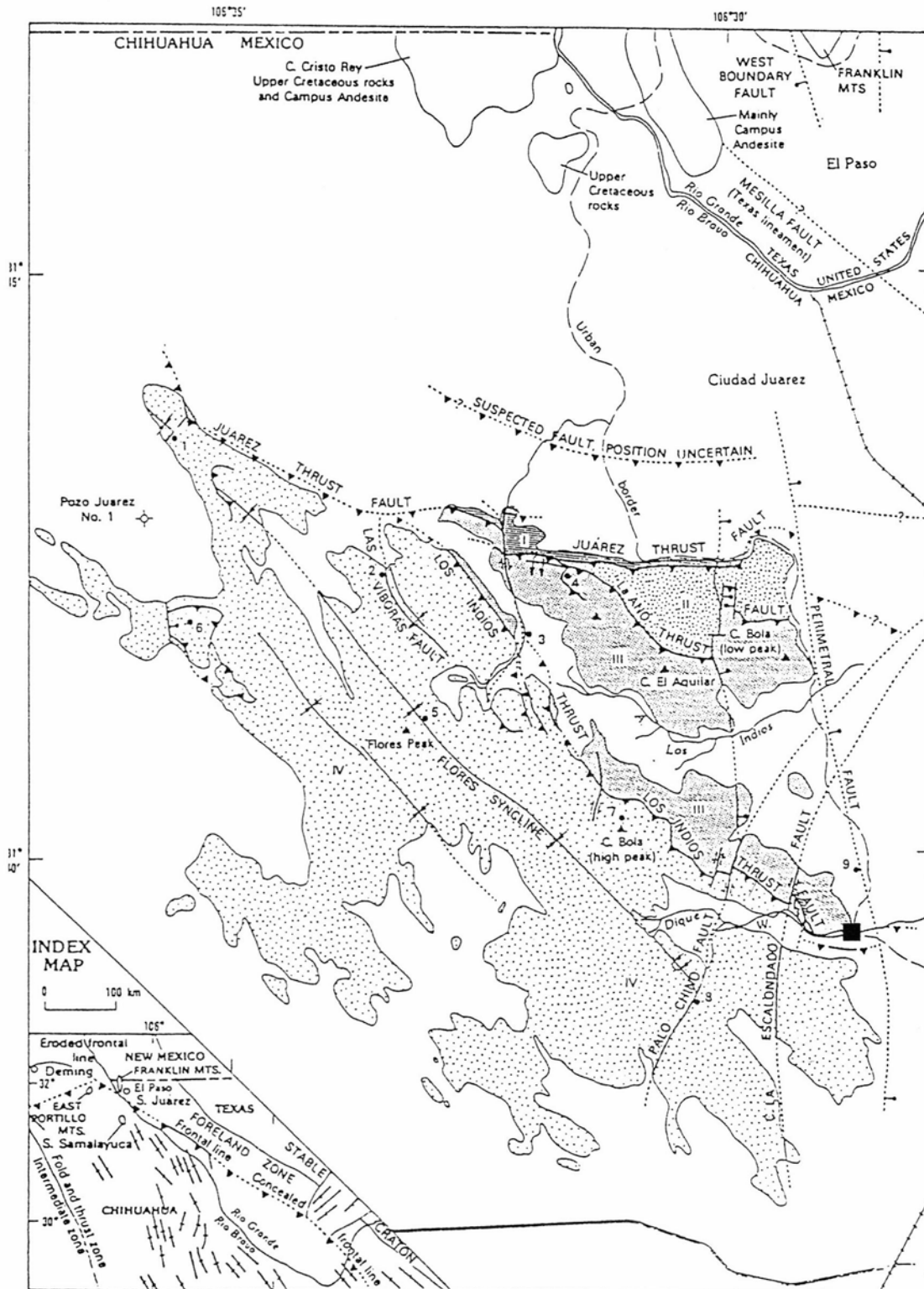

FIGURE 1—Geologic map of the Sierra de Juárez showing major structural features and its regional setting (from Drewes and Dyer, 1993). The opaque square marks the position of the Cementos de Chihuahua plant and quarry complex.

Lower Cretaceous to lowermost Upper Cretaceous (Albian—Turonian). The rocks in the lower sequence, the Cuchillo, Benigno, and Lagrimas Formations, underlie about 90% of the sierra. These three formations are well exposed in the cement quarry.

The Cuchillo Formation is very characteristic and easy to distinguish from other formations. It has a brownish-gray color and abundant clastic material. The lower mem-

ber of the formation is a black to gray siltstone, while the middle member is a major cliff former and browner. The upper member exhibits oolitic limestone and pebble conglomerates.

Overlying the Cuchillo Formation is the Benigno Formation. It is very light in color and consists of three members. The upper and lower members have interbedded mainly or shaly rocks with thin micritic limestone beds.



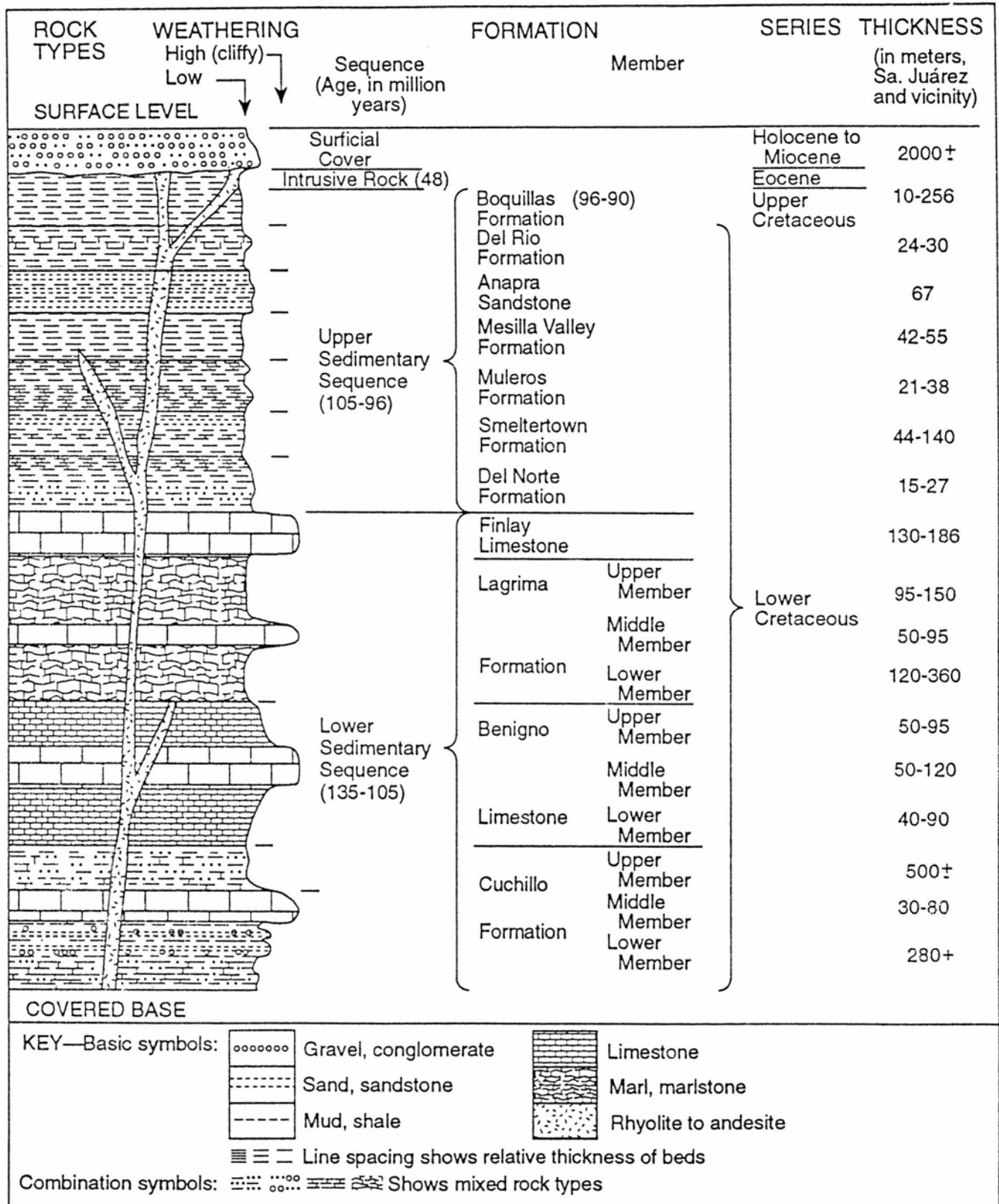

FIGURE 2—Stratigraphic column for the Sierra de Juárez (from Drewes, 1992).

The middle member forms massive cliffs of coral, rudist, and algal material in the sierra.

Above the Benigno is the Lagrimas Formation that is also a cliff-forming unit. Most of this formation is a marl-stone or an alternating shale and thin-bedded, fine-grained limestone. The formation is the most easily

eroded of the widespread units of the lower Cretaceous sequence in the sierra and thus commonly underlies broad longitudinal valleys in which gravels conceal the bedrock. The limestone is mainly micritic, very light gray, and in some beds, nodular.

The Finlay Limestone overlies the Lagrimas and is an-

other thick-bedded to massive, light-gray, reef limestone with sparse, thin, mainly interbeds. The limestones are commonly wackestones.

### Structure

The cement plant and quarry are situated at a relatively complex junction of various faults (Fig. 1). There is a north-south-trending strike-slip fault and two parallel northwest-southeast-trending thrust faults. In addition a right lateral strike-slip fault offsets both thrust faults.

Folding is extreme on the northwest side of the Cerro Escalonado upon which the plant/quarry site is situated. Overturned beds are common while other beds have average dips of 70-80° NNE. Bench cuts at the quarry site expose almost vertical beds. However folding toward the southeast of the strike-slip fault is very slight. The beds exposed on this side dip approximately 20-35° NNE.

### Corporate structure

Cementos de Chihuahua was privately incorporated in 1941 in Chihuahua City where most of their cement production was concentrated until 1972 with the completion of the Juarez cement plant and quarry. The initial production rate was 70,000 mt of cement in 1972, with an annual production capacity of approximately 250,000 mt.

Presently the Monterrey-based Cementos Mexicanos (CEMEX) has 49% ownership in Cementos de Chihuahua. Common stock is openly traded on the Mexican stock exchange or Bolsa de Valores. The present corporate structure is divided into nine wholly owned subsidiaries that are interdependent for the production and distribution of cement products. Generally the corporate structure has three divisions: acquisition of raw materials, production, and marketing. Operating under the corporate acronym Camsa (Control Administrativo Mexican, S.A.) the nine companies are:

Cementos de Chihuahua—Actual production of cement  
Materiales Industriales—Mining and quarry operations  
Minera Raramuri—Exploration and raw materials acquisition

Talleres y Equipos—Equipment maintenance

Calhira y Mortero—Concrete marketing and distribution

Distribuidora El Jurado—Cement-product marketing in Chihuahua City

Coprechisa—Cement-product marketing in Chihuahua City

Construcentro—Prefabricated concrete wall slabs

Mexcement—Cement-product marketing in the United States

### Mining

Bulk open-pit (quarry) mining is employed to remove the limestone in the sierra. The entire mining and production operations are conducted on the Cerro Escalonado area of the sierra. The mining on the property is conducted by their subsidiary Empresa Materiales Industriales de Chihuahua, S.A. An older quarry site on the property, dating back to 1972, is currently being used as a storage site for shale used in cement manufacture. Gypsum for cement production is quarried and transported from another company property in the Mexican state of Chihuahua. Hematite, another raw material, is purchased and transported from Durango, Mexico.

The present quarry has three main benches (Garcia, 1993). The benches are cut at 10 m intervals starting at a 1,300 m marker. Explosives are used for blasting. Currently some of the Benigno Formation is quarried but the Lagrimas Formation is the principal source of limestone. Lagrimas limestone presently exposed consists of a medium- to light-gray biostrome reef unit with a 90% CaCO<sub>3</sub> content. The middle member of the Lagrimas Formation is a thick limestone unit with some gray shales with 80-90% CaCO<sub>3</sub> content. At the quarry site the lower member is composed of light gray shales, thin mudstones, and marls.

### Production

Combined capacity for both the Chihuahua City and Ciudad Juarez plants is approximately 1,100,000 mt per year. In recent years the annual production at the Juarez plant has been approximately 160,000 mt. The average daily production rate at the Juarez plant is 400 mt of cement clinker. With additives it produces 600 mt of cement per day. The Chihuahua City plant is averaging 900,000 mt of cement annually.

Storage capacities for raw materials are: 4,000 mt of shale, 6,000 mt of limestone, 3,000 mt of gypsum, 3,500 mt of crude mix, 13,000 mt of clinker, and 3,500 mt of special clinker. The blended dry mix consists of approximately 80 wt.% limestone, 19 wt.% shale, and 1 wt.% hematite. This mix is pre-heated at 60-70°C. Subsequently it enters the rotary kiln, which has a temperature of approximately 1,450°C. After cooling, the newly formed clinker is mixed with 5 wt.% gypsum added before final grinding.

### Acknowledgements

The author would like to thank the Juarez plant director Lic. Oscar Del Valle for permission to access the plant and quarry site during an initial and subsequent visits starting in 1993. Special thanks go to Ing. Alberto Flores, plant engineer, for the comprehensive information on company history, corporate structure, and plant operations. In addition, Ing. Guillermo Delgado and Ing. Pedro Dour, both of Materiales Industriales de Chihuahua, provided background information on the quarry operations. Drs. Kenneth F. Clark and George S. Austin critically reviewed the manuscript.

### References

- Campuzano, J., 1973, The structure of the Cretaceous rocks in the southeastern part of the Sierra de Juárez, Mexico: Unpublished MS thesis, University of Texas (El Paso), pp. 7-10, 16-33, 54, 73.
- Cordoba, D. A., 1969, Mesozoic stratigraphy of northeastern Chihuahua, Mexico: Guidebook of the Border Region, New Mexico Geological Society, Guidebook 20, pp. 91-97.
- Drewes, H., 1992, Geological overview of the Sierra de Juárez, Chihuahua, Mexico: El Paso Geological Society, Guidebook for the 1992 Field Conference, pp. 67-72.
- Drewes, H., and Dyer, R., 1993, Geologic map and structure sections of the Sierra de Juárez, Chihuahua, Mexico: U.S. Geological Survey, Miscellaneous Investigations Series, Map 1-2287, scale 1:12,500.
- Garcia, G., 1993, Mineralogy and economic exploitation of the Lagrimas Formation for the production of portland cement by Cementos de Chihuahua: [Unpublished Report], University of Texas (El Paso), 64 pp.

# Brucite deposit in Marble Canyon, Culberson County, Texas

Tom Newman' and Gretchen K. Hoffman'

J.M. Huber Corporation, P. O. Box 4005, Quincy, Illinois 62305, USA;

<sup>2</sup>New Mexico Bureau of Mines & Mineral Resources, New Mexico Tech, 801 Leroy Place, Socorro, New Mexico 87801-4796, USA

**Abstract**—A large brucite deposit is located in the eastern escarpment of the Sierra Diablo in Culberson County, Texas, 30 mi of north of Van Horn, Texas, and 3.1 mi west of Texas Highway 54. Brucite (Mg(OH)<sub>2</sub>) is regaining interest in industrial minerals as a flame-retardant filler and a titanium dioxide extender. Economic brucite deposits, at the volume levels and with purity characteristics existing in Marble Canyon, are extremely rare. Marble Canyon brucitic marble has been mined since 1963 by Texas Architectural Aggregates Inc.

The Marble Canyon brucite deposit results from alteration of the Bone Spring and Hueco Formations of Permian age. The Bone Spring dolomitic limestone and Hueco dolomitic limestones are metamorphosed to brucitic marble forming a circular aureole adjacent to a unique igneous intrusive stock of the Trans-Pecos magmatic province. Brucite was formed by contact metamorphism with the intrusion. The brucite ore zone is approximately 380 ft wide and approximately 1,000 ft thick and grades from 60 wt.% brucite near the igneous contact to 20 wt.% near the unaltered dolomitic limestones; overall average is 40 wt.% brucite. Brucite was formed as a product of dedolomitization by thermal metamorphism and enrichment by magnesium from the intrusive mass. The reaction is:

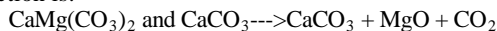

followed by rehydration:

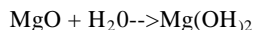

The economic value of brucite is being reevaluated. Brucite is a very effective TiO<sub>2</sub> extender and performance enhancer for opacity and adhesiveness in paints. Brucite offers flame-retardant/smoke-suppressant properties in polymer compounds by releasing 31% of its weight as water at a high processing temperature (330°C).

## Depósito de brucita en Marble Canyon, Condado de Culberson, Texas

**Resumen**—Un extenso depósito de brucita aflora en la escarpa oriental de la Sierra Diablo en el Condado de Culberson, Texas, 30 millas al norte de Van Horn, Texas, y tres millas al oeste de la Carretera Estatal de Texas 54. Brucita (Mg(OH)<sub>2</sub>) está atrayendo renovado interés industrial como material de carga retardador de llamas y extendedor de dióxido de titanio. Son sumamente escasos los depósitos económicos de brucita que pueden compararse con el yacimiento de Marble Canyon en cuanto a reservas y pureza del mineral. El mármol brucítico de Marble Canyon ha sido explotado desde 1963 por la empresa *Texas Architectural Aggregates Inc.*

Este depósito es el resultado de alteración de las formaciones pérmicas *Bone Spring* y *Hueco*. Las calizas dolomíticas de estas formaciones han sido metamorfizadas a mármol brucítico en una aureola circular adyacente a un stock igneo intrusivo de la Provincia Magmática de Trans-Pecos. La brucita se forma por metamorfismo de contacto con la intrusión. La zona mineralizada tiene un ancho de aproximadamente 380 pies con un espesor de unos 1,000 pies. La ley de brucita disminuye de 60% por peso cerca del contacto igneo a 20% cerca de las calizas dolomíticas sin alterar. La ley media en brucita es del 40%. La brucita es producto de la dedolomitización por metamorfismo termal y enriquecimiento de magnesio procedente de la masa intrusiva. La reacción es como sigue:

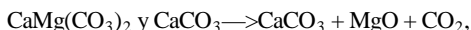

seguida por rehidratación:

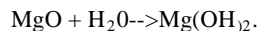

Estamos en el proceso de nuevamente estimar el valor de la brucita. Este mineral es un extendedor efectivo de TiO<sub>2</sub>. Incrementa la opacidad y adhesividad de pinturas. En los compuestos de polímeros actúa de retardador de llamas y supresor de humo. Brucita comienza a descomponerse a la temperatura de 330°C desprendiendo agua equivalente al 31% de su peso.

### Introduction

The Sierra Diablo Plateau in Culberson County, west Texas, contains exposed laccoliths, stocks, dikes, and sills mapped as Tertiary intrusions. One igneous complex, in Marble Canyon, was emplaced with little deformation of the overlying, calcareous Permian strata. The igneous complex is surrounded by a zone of white brucitic marble and calc-silicates that include the contact metamorphic

aureole produced by the emplacement of igneous rock into calcareous sediments. This affords the opportunity to study the origin of the brucitic marble of Marble Canyon (Fig. 1).

Marble Canyon lies within the frontal scarp of the Sierra Diablo at an elevation of about 4,600 ft and is located on the Two Ranch and Apache Peak 71/2 minute topographic quadrangles. From 30 mi north of Van Horn

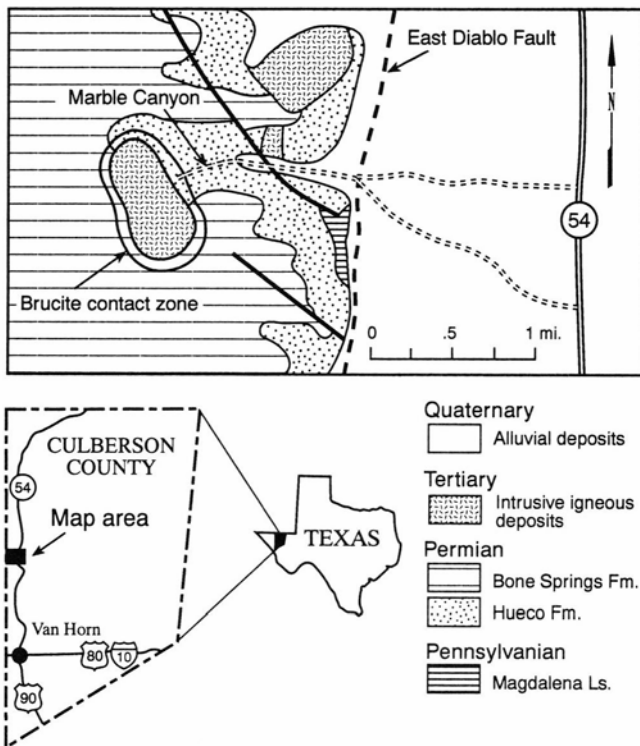

FIGURE 1—Location map of Marble Canyon, Culberson County, Texas.

on Texas Highway 54, a graded haul road trends westerly 3.1 mi to the Texas Architectural Aggregates Inc. (TAA) underground brucite mine.

Two characteristics make the Marble Canyon deposit unique. First the marble contains an unusually high percentage of brucite. Second there is a very small percentage of other minerals present. The uniformly white, fine-grained marble product is used as terrazzo, landscaping, exposed-aggregate material, paint filler, and as flame retardant in plastics.

### Geologic setting

Marble Canyon is one of several deep re-entrants eroded into the eastern escarpment of the Sierra Diablo Plateau. This dissected eastern rim is underlain by slight east-dipping dolomitic limestone and dolomite of the Permian Hueco and Bone Springs Formations that unconformably overlie older Paleozoic and Precambrian rocks. Headward erosion has cut the canyon back into the towering cliffs that have been upthrown by faulting. The canyon entrance is a narrow gorge but unlike other canyons, in less than 1.6 mi it widens into a large, north-south-oriented, 0.9 mi long, oval-shaped amphitheater, 0.6 mi wide (Fig. 1). Marble Canyon was formed by the erosion of the Tertiary intrusive igneous complex, its contact aureole, and the overlying strata. Small intermittent streams drain the canyon at the northeast corner and discharge into the Salt Flat Bolson.

The northeastern section of the Tertiary intrusion is in the dolomitic Hueco Formation; the rest of the contact is in the dolomitic limestone Bone Springs Formation (Fig. 2). The Hueco Formation is 459 ft thick and in this area is gray, dolomite in unmetamorphosed areas (Fig. 3). Metamorphosed Hueco is a white marble composed of brucite and calcite 591 ft thick around the intrusive complex.

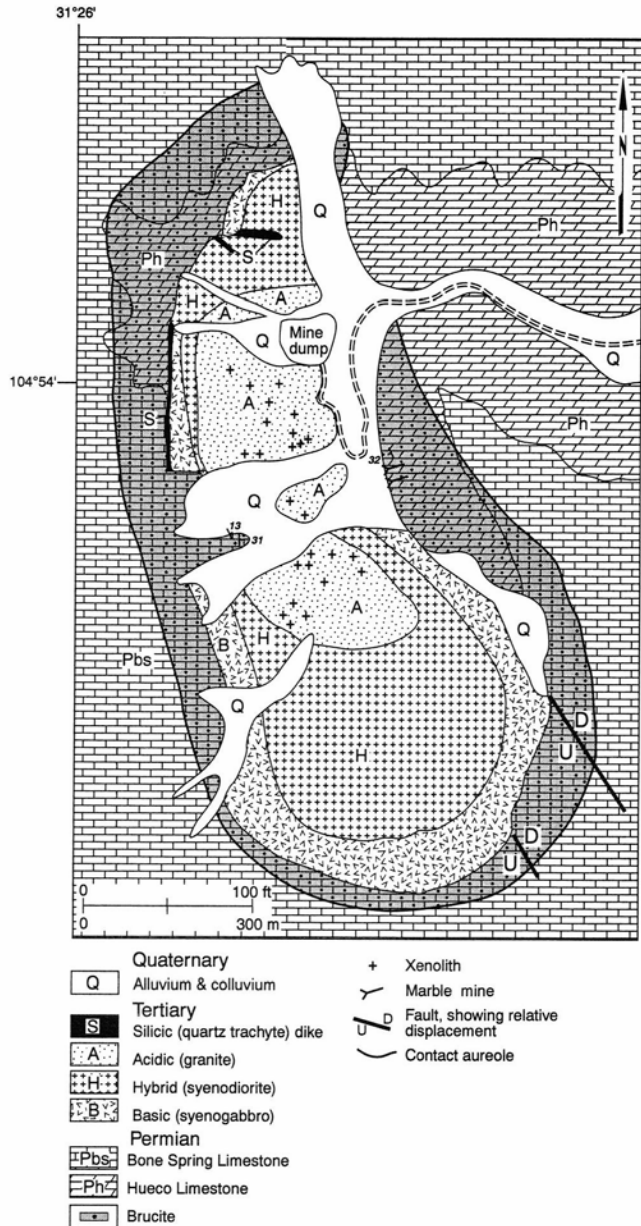

FIGURE 2—Geologic map of Marble Canyon (modified from King et al., 1965, and Bridge, 1996).

The Bone Springs Formation is 1,270 ft thick and composed of brown, cherty dolomitic limestone and thin shale. The metamorphosed Bone Springs Formation does have brucite but is composed mostly of high temperature calc-silicates. Because of this assemblage, its value as a brucite source is very limited.

### Igneous complex

The center of Marble Canyon is dominated by an extensively studied elliptical igneous complex 4,593 ft by 984 ft. There is little deformation of the country rock by the intruded igneous complex. This suggests very subtle invasion and transformation of the country rock into the igneous body. Based on mineralogy, the intrusion and assimilated country rock emplacement were at very high temperatures. Complete reconstitution of the country rock into the igneous body altered the magma's composition into a complex mass.

The igneous rocks of Marble Canyon are roughly divided into three major zones by rock type. The zones from

System	Formation & Member	Thickness (feet)	Columnar Section	Description
Quaternary	Undivided	16		Alluvium & colluvium
Tertiary	Marble Canyon stock, Cave Peak intrusions			Alkali gabbro to granite intrusions
Permian	Victorio Peak Limestone (Leonardian)	499		Thickly bedded limestone, in part slightly dolomitic
	Bone Spring Limestone (Leonardian)	1270		Thinly to thickly bedded, locally dolomitic & cherty limestone
	Hueco Limestone (Wolfcampian)	276		Thinly bedded dolomitic limestones with minor shale partings & chert nodules
		82		Irregularly bedded & massive limestones with abundant fusulinids; minor marly & dolomitic limestones
		Pow Wow Member	39	
		62		Fluvial, conglomerates & sandstones
Pennsylvanian	Undivided	171		Limestones with brachiopods, crinoids, & corals

FIGURE 3—Stratigraphic column, Marble Canyon area (modified from Price et al., 1986).

the outer border of the complex to the center are: a dark syenogabbro (Fig. 2, basic rock), a gray and green syenodiorite (Fig. 2, hybrid rock), and a hornblende-biotite granite (Fig. 2, acidic rock). Changes between the zones are highly gradational at the individual contacts. The field differentiation into rock zones is based on color, mineralogy, weathering, and textural variations.

Dikes and veinlets crosscut the igneous complex. Rock types include nepheline syenites and rhyolite. These dikes and veinlets vary in width from 2.5 inches to several feet and from fine- to coarse-grained texture. The larger dikes form radiating rosettes in the central zones.

Structural features of the igneous complex are characterized by long east—west joints in the south and central

zones. Since the emplacement of the igneous complex, no major faulting has been observed.

The igneous mineral assemblages of the outer two zones are products of the reaction of the absorbed rocks (dolomite and dolomitic limestones) and the intruding magma:

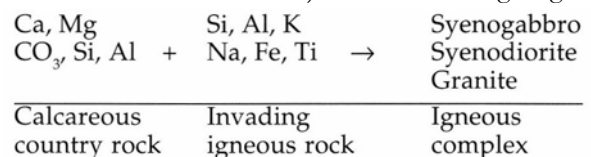

The outer zones of the igneous complex are most important to the formation of the brucitic marble. These zones are essentially gabbroic with calcium/magnesium

feldspathoid minerals making up the balance. The occurrence of the calcium-rich minerals tends to support formation of these igneous rocks that utilized calcium from the Hueco and Bone Spring Formations. Other mineral components in these syenogabbros were supplied by invading magma.

The high temperatures (700-800°C) of the invading igneous rock altered the assimilated dolomitic country rock, making magnesium available to form syenogabbros and syenodiorites (Table 1). The magnesium utilized is less than what was available in the dolomite (theoretical 31 wt.% MgO). The surplus magnesium in the assimilated rock migrated and enriched the surroundings Hueco and Bone Spring Formations creating a contact metamorphic brucite zone that extends outward over 591 ft (Fig. 2).

### Brucitic marble

Brucitic marble forms a calcareous metamorphic contact zone around the igneous stock. The Hueco and Bone Spring Formations are the altered rock units. Only the Hueco Formation contains brucitic metamorphic zones large enough for economic use. The Hueco Formation also contains more than the normal theoretical limit of brucite. The metamorphosed Bone Spring Formation has low-grade brucite and is not considered economically important at this time.

Brucitic marble was the final product of the contact metamorphism of the ingenious complex. The brucite mineralogy was dependent on several factors such as chemistry of the igneous magma and the invaded carbonate strata, water content, and the temperature and pressures at the time the magma was being emplaced.

The altered Hueco Formation was initially pure dolomite. Heat and pressure to create brucite are interpreted as products of dedolomitization in two ways. The principal method of alteration is:

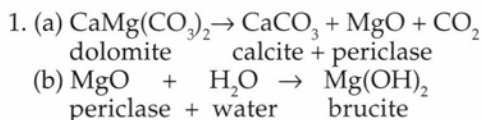

Under rare conditions large tabular brucite can form by direct conversion of dolomite to brucite:

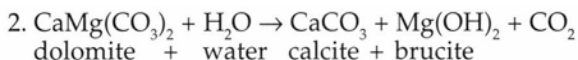

The heat and pressure of the igneous complex penetrated the dolomitized Hueco Formation, resulting in good permeability and porosity that allowed for a wider zone of brucitic alteration. Periclase produced during and after the emplacement of the igneous complex stock reacted when H<sub>2</sub>O invaded the porous strata, producing an aureole with brucite.

Analyses of other brucite limestones show MgO and CaO to be present in proportions closely corresponding with the original dolomite. If the entire brucite deposit were formed from pure dolomite, the maximum amount of brucite that could occur would be 36.7 wt.%. The incorporation of the Hueco and Bone Springs Formations

into the intrusive body supplied super-rich magnesium fluids that penetrated back into the brucite contact zone. The Marble Canyon deposit exceeds the theoretical maximum amount of brucite; brucite content is over 60 wt.% near the igneous contact with an average of about 40 wt.%. This suggests the deposit has been enriched in magnesium from the altered igneous complex.

### Mining history

Marble Canyon's brucitic marble deposit has a recent mining history. The deposit was discovered before 1905, but little was mined. The original company, Texas Construction Materials Corporation (TCM), started development as a dimension stone quarry in the early 1960s. TCM spent approximately \$350,000 on improvements such as roads, derricks, and an open pit quarry. The brucitic marble proved to be too fractured for mill block quarrying and the mine was put up for sale.

Texas Architectural Aggregate (TAA) subsequently purchased 40 acres and the associated access road from Texas Construction Materials in 1963. Texas Architectural Aggregate also obtained the mineral rights and prospect rights from the State of Texas on an additional 340 acres in and around Marble Canyon. TAA continues to explore for brucite via core drilling.

In 1964 TAA started mining underground using a room-and-pillar method. TAA's first market for the brucitic marble is decorative chips. Crushed ore is trucked from the Marble Canyon Mine 30 mi south to a rail siding at Van Horn, Texas, but there are no processing facilities in Van Horn. From Van Horn the brucitic marble is railed to San Saba, Texas, for final processing at TAA's facility, a distance of 400 mi. The rail freight in 1964 was \$2.97/short ton (st) and took three days; by 1990 the cost was \$28/st and took 15 days to reach San Saba, Texas. Trucking costs decreased during that same period. TAA started trucking the brucitic marble in the 1980s. Today trucking represents 50% of freight tonnage. The present Marble Canyon operation nominally employs a staff of five.

TAA made many discoveries processing the brucitic marble at the mine. Most notable, jaw crushing or cone crushing was ineffective because of the brucite slippage along the crushing plates. Experience proved that impact crushing is the most effective process.

### Mining

Today the mining in Marble Canyon is by the underground room-and-pillar method. Exploratory efforts are being made to produce from a small open pit development above the mine. The underground mine now covers approximately six acres. Brucitic marble is highly fractured due to the metamorphic process of magnesium emplacement. These innumerable fractures trend N35°W and are cemented with fracture-filling brucite. The mine terminates 900 ft to the east in unaltered gray Hueco dolomite.

The rooms are 35 ft wide and 30 ft high and pillars are 50 ft by 50 ft. There are about six active faces at any one time. Blasting is performed every three days. Face drilling is done with a Tamrock DHA-500 single-boom track-drive drill with 14 ft drill steel, one hole taking about 6 min to drill. Each face requires 25-30 2.5 inch diameter holes using 400 lbs of ammonium nitrate explosives. Each explosion can extract approximately 250 st of brucitic marble.

Two caterpillar front-end loaders, (#920 and #953) are used to load the shot rock into 12-st dump trucks. The

TABLE 1—Magnesium oxide content in the Marble Canyon igneous complex.

Rock type	MgO wt. %
Syenogabbro	7.59
Green and gray syenodiorite	3.71
Granite	0.71

trucks haul the brucitic marble to the primary crusher located just outside the mine. See Figure 4 for processing diagram.

Proven reserves of 3.1 million st of brucitic marble have been measured around the mine site. Additional marble may be found in other areas in the canyon. There are indications of equally large brucite bodies encircling the north end of the aureole.

**Markets**

Today's markets for the Marble Canyon brucitic marble are expanding into value-added fillers. Traditionally the crushed marble is sold for architectural aggregates, terrazzo chips, plastering, athletic field liners, and precast exposed aggregate. Pulverized brucitic marble (-325 mesh) is used as filler material for paint and plastics. As a paint filler the brucite acts as a whitener and TiO<sub>2</sub> extender. In plastics the brucite acts as a whitener, and, more importantly, as a flame retardant/smoke suppressant.

Brucite has been found very effective as a titanium dioxide extender and performance enhancer in the formulation of high-quality paints. Grinding of the raw ore to less than 10 μm produces evenly distributed particles of brucite throughout the white calcite granules and allows for greater extension of TiO<sub>2</sub> than normal carbonate fillers. Brucite enhances both opacity and paint adhesiveness at TiO<sub>2</sub> replacement values of 10-40%. The result is a paint formulation that offers excellent hiding qualities and can be washed and scrubbed without deterioration.

**Flame retardant**

Minerals with flame retardant properties have had continued growth since legislation of the 1970s requiring plastics to be fire retardant. Certain minerals such as alumina trihydrate (ATH) and magnesium hydroxide

(Mg(OH)<sub>2</sub>) are being established as flame retardants in polymers.

Flame-retardant minerals act as a filler with strong endothermic decomposition properties. When heated to 150-400°C these minerals release considerable amounts of water and/or carbonate dioxide. The release of water and CO<sub>2</sub> retards smoke and corrosive gas evolution. A good match is needed between the polymer and a mineral's decomposition temperature. The principal limitation of ATH is its low decomposition temperature (180-200°C) limiting its use in plastics to those processed at low temperature. Brucite (magnesium hydroxide) can withstand processing temperatures as high as 330°C without decomposition, opening larger market opportunities. Marble Canyon brucite has been tested and decomposes at 330°C, releasing its water. Brucite, theoretically, contains 69 wt.% MgO and 31 wt.% H<sub>2</sub>O. See Figure 5 for thermogravimetric analysis (TGA) between ATH and brucite.

The potential of the Marble Canyon brucite as a flame retardant is just now being realized in the market. The decomposition characteristics mentioned above allow Marble Canyon brucite to be employed in plastics requiring higher processing temperatures than other hydrated minerals can withstand. The brucite reduces smoke levels and aids neutralization of toxic combustion of off-gases. Potential applications include adhesives/sealants, PVC (rigid, flexible, plastisols), rubber, wire/cable, and roofing.

**Summary**

The following summarizes the geologic properties of Marble Canyon: (1) One major metamorphic rock type and three major igneous rock types were found in Marble Canyon: brucite, syenogabbro, green and gray syeno-

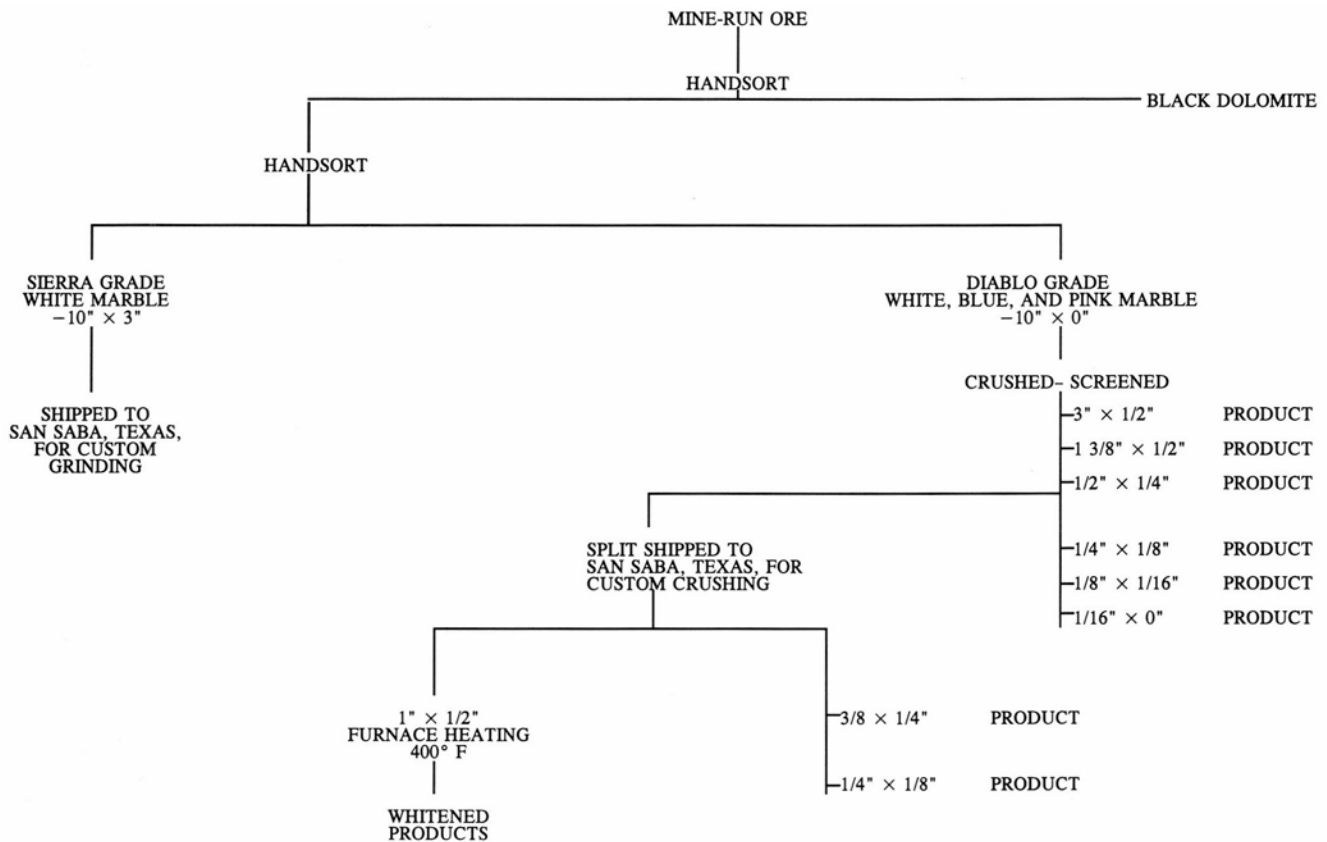

FIGURE 4—Processing diagram of operation at Texas Architectural Aggregates Marble Canyon mine.



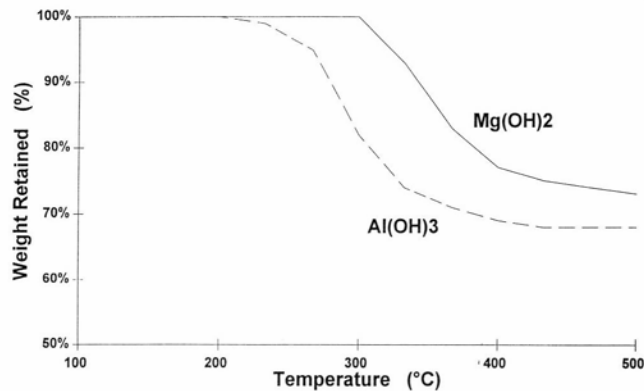

FIGURE 5—Relative thermal stabilities of aluminum and magnesium hydroxides by thermal analysis (TGA).

diorite, and granite. (2) The igneous rocks are mappable units that represent degrees of inclusion of surrounding carbonate country rock. Granite forms the pure igneous inner core then grades outward to the syenogabbro. (3) Numerous dike and veinlets cut all igneous rock units and vary in composition from nepheline syenites to rhyolite. (4) The structure of the canyon is relatively simple. Stratigraphic dip of the carbonate country rock suggests a quiet emplacement of the igneous plug. East-west joints are seen in the igneous complex. (5) The "soaking and diffusion" of the country rock into igneous complex provided surplus magnesium to be infused into the carbonate rocks immediately adjacent. Dolomitic porosity aided in creating a wide zone of super magnesium compounds. (6) The igneous complex created a contact metamorphic zone of calcite and periclase. Rehydration converted the periclase to brucite. (7) Zones in Marble Canyon are super-rich in brucite (>40 wt.%) exceeding the theoretical maximum amount of magnesium simple conversion of dolomite (36.7 wt.%).

TAA's market for Marble Canyon brucite has traditionally been as architectural aggregates or terrazzo chips, but other markets are being explored: (1) Brucite is a very effective  $\text{TiO}_2$  extender and performance enhancer for opacity and adhesiveness in paints. (2) Brucite also acts as a whitener in plastics and offers flame retardant/smoke suppressant properties in polymer compounds. It starts decomposing at  $330^\circ\text{C}$  releasing 31 wt.% of its weight as water, allowing brucite to be used in plastics requiring higher processing temperatures than other hydrated minerals can withstand. (3) Brucite also reduces smoke levels and aids in neutralizing toxic combustion of off-gases. Potential uses include adhesives and sealants, PVC, rubber, wire/cable, and roofing. (4) In addition, Marble Canyon brucite is relatively in

soluble, has a Mohs hardness of less than 4, a low aspect ratio, and low-cost processing to enhance its viability in this market.

#### Acknowledgment

The authors thank Engineered Minerals Division, J. M. Huber Corporation, for encouraging this project. Special thanks to Lois Campbell and Angel Kline for their efforts. The senior author wishes to express his deep feeling of gratitude to his wife, Patti, and daughter, Sara, for their understanding and support of his endeavors.

#### General References

- Bridge, T. E., 1966, Contact metamorphism in siliceous limestone and dolomite in Marble Canyon and geology related intrusion, Culberson County, Trans-Pecos Texas: University of Michigan Microfilms, Ann Arbor, Michigan, 156 pp.
- Calengas, P. L., 1995, Petrology of brucitic marbles, Van Horn, Texas: [Unpublished report], J. M. Huber Corp., Quincy, Illinois.
- Champine, N. G., 1990, Industrial markets for minerals: [Unpublished report], J. M. Huber Corporation, Quincy, Illinois.
- King, P. B., 1948, Geology of the southern Guadalupe Mountains, Texas: U.S. Geological Survey, Professional Paper 215, 183 pp.
- King, P. B., 1962, Leonard and Wolfcamp series of Sierra Diablo Texas; in Leonardian facies of the Sierra Diablo region, west Texas: Society of Economic Paleontologists and Mineralogists, Permian Basin Section, Field Conference Guidebook 62-7, pp. 42-65.
- King, P. B., and Knight, J. B., 1944, Sierra Diablo region, Hudspeth and Culberson Counties, Texas: U.S. Geological Survey, Oil and Gas Preliminary Map 2, scale 1:62,500.
- King, P. B., Henbest, L. G., Yochelson, E. L., Cloud, P. E., Dunbar, H., Finks, R. M., and Sohn, I. G., 1965, Geology of Sierra Diablo region, Texas, with special determinative studies of Permian fossils: U.S. Geological Survey, Professional Paper 480, 185 pp.
- Kuehn, W., 1969, Geologic and petrographic studies of Marble Canyon igneous complex, Culberson County: Unpublished MS thesis, Texas Christian University, 59 pp.
- Price, J. G., Henry, C. D., Parker, D. F., and Barker, D. S., 1986, Igneous geology of Trans-Pecos Texas, Field trip and research articles: University of Texas (Austin), Bureau of Economic Geology, Guidebook 23, 360 pp.
- Root, R. L., 1981, Report of survey to Texas Aggregate, Culberson County, Texas: [Unpublished report], J. M. Huber Corporation, Quincy, Illinois.
- Rothon, R., 1994, Mineral requirements for retardants: Industrial Minerals, No. 327, pp. 51-53.
- Sharp, J. E., 1979, Cave Peak: A molybdenum-mineralized breccia pipe complex in Culberson County: Economic Geology, v. 74, pp. 517-534.
- Williams, J. R., 1994, Mining history of marble, west Texas: [Unpublished report], Texas Architectural Aggregate (TAA), San Saba, Texas.



# Texas—Industrial minerals, imports, and exports

Palmer C. Sweet

P. O. Box 5469, Charlottesville, Virginia 22905, USA

**Abstract**—Industrial-mineral production in Texas during 1993 amounted to \$1,393,637,000. The bulk of this production is cement, construction sand and gravel, and crushed stone. Texas ranks second, behind California, in cement production, second in production of crushed stone (behind Illinois) and fourth, behind California, Michigan, and Ohio in production of construction sand and gravel.

Other commodities produced include alumina, ball clay, bentonite, common clay, dimension stone (granite, limestone and sandstone), fuller's earth, gemstones, gypsum, helium, industrial sand, iron ore, kaolin, lime, magnesium compounds, magnesium metal, salt, sulfur, talc, and zeolites. The state continues to rank number one, in the United States, in production of magnesium metal, common clay, and zeolites. Texas also ranks second in production of helium (crude), salt, sodium sulfate, and talc and third in production of ball clay and gypsum.

Fossil-fuel production is large in the State and in 1992 included more than 50 million metric tons (mt) of coal, 650 million barrels of petroleum, and 6.18 trillion cubic ft of natural gas. Texas ranks first in the United States in production of both petroleum and natural gas.

Industrial minerals are both imported and exported through most of Texas ports including Brownsville, Corpus Christi, Freeport, Galveston, Houston, Point Comfort, and Port Arthur.

## Importación y exportación de minerales industriales en Texas

**Resumen**—En 1993, la producción tejana de minerales industriales Rego a \$US 1,393,637,000; la mayor parte de esta producción fue de cemento, arena y grava de construcción y de agregados de piedra triturada. Texas ocupa segundo lugar, después de California, en la producción de cemento; segundo lugar también en producción de agregados de piedra triturada (después de Illinois); y cuarto lugar en la producción de arena y grava para construed& (después de California, Michigan y Ohio).

Otros productos son alúmina, arcilla cerámica (*ball clay*), bentonita, arcilla común; piedra cortada (*dimension stone*) de granito, caliza y arenisca; arcillas absorbentes (*fuller's earth*), piedras preciosas, yeso, helio, arena industrial, mena de hierro, caolin, cal, compuestos de magnesio, magnesio metálico, sal, azufre, talco y zeolitas. Texas ocupa primer lugar, dentro de los Estados Unidos, en la producción de magnesio metálico, arcilla común y zeolitas. Texas es segundo en la producción de helio (crudo), sal, sulfato de sodio, y talco y tercero en arcilla cerámica y yeso.

La producción de combustibles fósiles es grande y en 1992 excedió las 50 millones de toneladas métricas de carbon, 650 millones de barriles de petróleo, y 6.18 trillones de pies cúbicos de gas natural. Texas es primero en la producción de petróleo y gas natural en los Estados Unidos.

Minerales industriales son exportados e importados por la mayoría de los puertos tejanos, como ser Brownsville, Corpus Christi, Freeport, Galveston, Houston, Point Comfort, y Port Arthur.

### Introduction

According to the U.S. Bureau of Mines, Texas ranks sixth in the United States in nonfuel-mineral production with a total value of \$1,393,637,000 in 1993. The state continues to rank number one in production of common clay, magnesium metal and zeolites and number two in production of cement, crushed stone, helium (crude), salt, sodium sulfate, and talc (Fig. 1). A large quantity of industrial mineral commodities is exported out of Texas, often via ports (Fig. 2), including alumina, bentonite, dimension granite and limestone, and kaolin. Texas ranks third in production of gypsum, which is both imported and exported. Following is descriptive information on many of the industrial-mineral commodities produced and/or imported from out-of-state sources and processed in Texas.

Texas ranks first in the United States in production of both petroleum and natural gas. In 1992 fossil-fuel production included more than 50 million mt of coal, 650 million barrels of petroleum, and 6.18 trillion cubic ft of natural gas.

### TEXAS 1993 NONFUEL MINERAL PRODUCTION

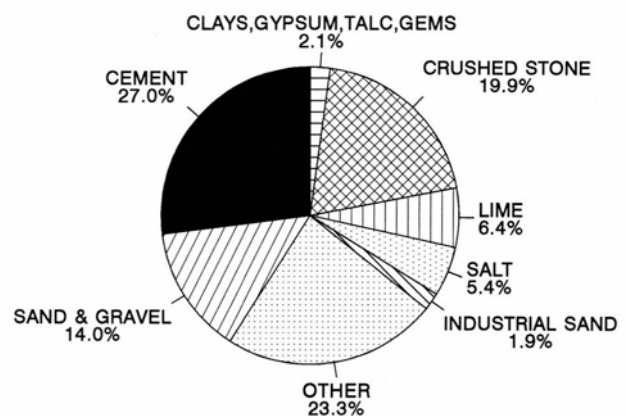

FIGURE 1—Industrial-mineral commodities produced in Texas.

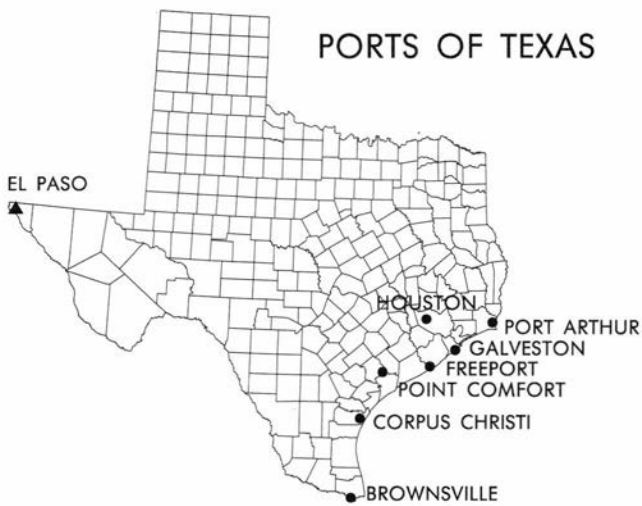

FIGURE 2—Ports of Texas.

### Industrial-mineral commodities

#### Alumina

Alumina is produced at several facilities, using imported bauxite. Reynolds Metals Company produces alumina at its Sherwin refinery near Corpus Christi, and Aluminum Company of America (ALCOA) continues to produce alumina at its Point Comfort refinery in Calhoun County; the latter company also operates an aluminum smelter near Rockdale in Milam County, northeast of Austin.

During 1993, 715,893 mt of alumina valued at almost \$135 million were exported through the port of Corpus Christi along with 2.66 million mt of bauxite (aluminum ore) valued at more than \$47 million and mined out-of-state. Almost 4,200 mt of bauxite were imported into Brownsville, Texas.

#### Ball clay

In 1992 Texas was the third leading producer of ball clay out of five states. Extensive reserves of ball clay, which is in the upper portion of the Wilcox Group of lower Eocene age, have been produced near Henry's Chapel and Troup in Cherokee County southeast of Dallas. This ball clay is tough and light bluish gray when fresh, and almost white when bleached by the sun. Ball clay in this area is extensive, averages just under 2.5 m in thickness, and overlies a lignitic clay. The clay is overlain by the sand of the Carrizo Formation of the Claiborne Group. The basal disconformity of the sand is the most important geologic condition limiting the extent of the ball-clay deposits.

United Clays Inc., the second largest ball-clay producer in North America according to Watts Blake Bearne and Company's annual report, marketed most of their clay to the ceramic-tile industry in 1992, when production was up 25%. During that year export figures to Mexican ceramics industries multiplied sevenfold (Dupree and Garner, 1992).

#### Barite

Several companies import barite into Texas to produce drilling muds. Milwhite Company Inc. operates grinding plants in Cameron County near Brownsville and in Harris County near Houston; Excalibur Minerals also operates a grinding plant near Houston; M-I Drilling Flu

ids Company (a subsidiary of Dresser Industries Inc.) operates a grinding plant in Galveston County near Galveston; Old Soldier Minerals operates a grinding plant in Webb County at Bruni; and Milpark Drilling Fluids operates a grinding plant in Nueces County.

Drilling muds are imported through the ports of Galveston, Houston, and Point Comfort (Fig. 1) with the main importing countries in 1993 being Israel, Belgium, Netherlands, the United Kingdom, and Germany. More than 175,000 mt of barium sulfate were imported through the port of Corpus Christi in 1993.

Barite (drilling mud) is exported to more than 60 countries. Through the port of Houston the top five foreign destinations (more than 36,000 tons in 1993) are Venezuela, Trinidad and Tobago, Nigeria, Ecuador, and the United Kingdom. Export of drilling muds through Galveston went to Egypt, Guatemala, Netherlands, Brazil, and the United Kingdom.

Filler-grade barite is produced by Milwhite Company Inc., M-I Drilling Fluids, Excalibur Minerals, Old Soldier Minerals, and also by Hitox Corporation of America near Corpus Christi.

#### Bentonite

Production and value of bentonite in Texas increased about five percent in 1992, and the State ranked seventh out of 13 producing states. Sodium bentonite (swelling) is mined by Border Mines near Alpine in Brewster County east of Presidio near the Mexican border, and calcium bentonite (fuller's earth) is mined by Mid-Tex Minerals Inc. in Fayette County west of Houston; raw material from the latter operation is used to make waterproof seals and water treatment filters (Fig. 3).

Southern Clay Products Inc. produces bentonite clay in two counties. In Gonzales County, east of San Antonio, the company produces a white bentonite as well as an organo-bentonite which is marketed for use in cosmetics, detergent sheets, and pharmaceuticals. In 1992 Southern Clay Products also operated a mine in Angelina County producing a yellow bentonite, which is exported to Malaysia for production of acid-activated clays.

In 1993 bentonite was imported into Galveston from the United Kingdom (103 mt) and into Houston from Spain (212 mt). Exports during that year were from Galveston including bentonite to Belgium (2 mt), Chile

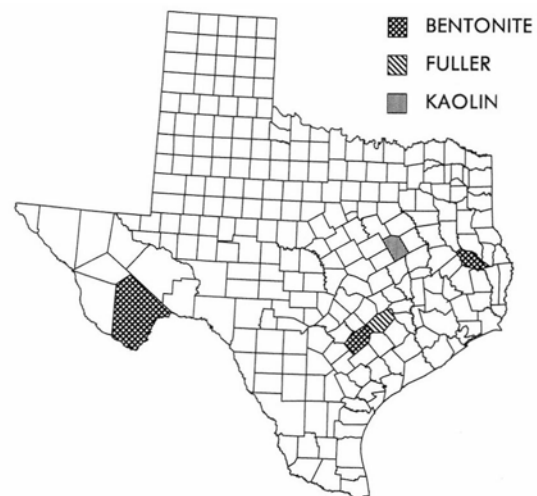

FIGURE 3—Bentonite, fuller's earth, and kaolin-producing counties in Texas.

(20 mt), Colombia (213 mt), France (272 mt), Guatemala (1 mt), and Israel (315 mt). Exports from Houston totaled 33,459 mt of bentonite to 27 countries. The largest recipient was Venezuela with 14,395 mt. Other countries receiving at least 2,000 mt of bentonite were Colombia, France, Netherlands, Nigeria, and Trinidad and Tobago. Thirty metric tons of bentonite were exported to Mexico through Port Arthur, Texas.

### Cement

In 1993, 8,342,000 mt of portland cement were produced at a value of \$376,518,000. Production increased steadily through the year, and Texas continues to rank second behind California of the 37 states producing port-land cement. Of the top 10 largest domestic cement companies, five operated plants in Texas according to the Portland Cement Association: Holnam Inc. in Ellis County; Lafarge Corporation in Comal, Dallas, and Tarrant Counties; Texas Lehigh Cement Company in Hays County; Lone Star Industries Inc. near Mayneal, southwest of Abilene; and Southdown Inc., in Odessa, Texas. Other producers were Alamo Cement Company (formerly known as San Antonio Cement, the oldest cement operation in Texas) in Comal County and Capitol Cement in Bexar County, both near San Antonio. Types I, II, and III gray portland cements are produced by most of the cement plants in Texas. Texas Industries' Midlothian plant, located south of Dallas-Fort Worth in Ellis County, produces a wide range of specialty cements including expansive and pozzolan portland cements. It appears that the production of masonry cement also increased in 1992; Texas ranked eighth of 36 states reporting production.

### Clay

Texas is the leading state in the production of common clay, 2.29 million mt valued at \$13.25 million in 1993. The Brick Institute notes that there are 10 companies manufacturing brick or structural tile in 13 counties mainly in the eastern half of the state. These companies are: Acme Brick Company, Texas Industries Inc., Athens Brick Company, Cordell Brick Company Inc., D'Hanis Brick and Tile Company, Elgin Brick Company, Henderson Brick Company (division of Boral Bricks Inc.), Mineral Wells Clay Products Inc., Texas Clay Industries, and U.S. Brick.

Clay mined in the state is also utilized as a source of alumina for use in the production of portland cement, for highway surfacing material, to manufacture structural concrete and to make pottery. Marshall Pottery Inc., located in Harrison County, has been in operation since 1895 producing hand-turned white and blue stoneware. The company shipped more than 5 million clay pots (from thimble size to 45 kg industrial size) in 1992.

### Construction sand and gravel

Texas ranks fourth behind California, Michigan, and Ohio in total production. In 1992 production amounted to 47 million mt of sand and gravel valued at \$195 million. According to the U.S. Bureau of Mines, projected from third-quarter figures, 1994 production will decrease by about 38%. The top 10 producing companies in Texas are: Pioneer Concrete of Texas Inc., The Fordyce Company, Beazer USA/Hanson PLC, Capitol Aggregates Inc. (H. B. Zachary Company), Lafarge Corporation, Texas Industries, Myre Construction Company Inc., Redland PLC, Mike Arnold Trucking and Material Company Inc., and Kerr Enterprises Inc.

Most of the sand and gravel production is from the floodplains of the Colorado River southeast of Austin, the Trinity River southeast of Dallas, the Rio Grande along the Texas-Mexico border, the Red River along the Texas-Oklahoma border, and the San Antonio River southeast of San Antonio (Fig. 4). Most (90%) of the product is transported by truck and the remainder by rail.

### Crushed stone

Texas ranked second (behind Illinois) in the production of crushed stone in 1993, with 68,900,000 mt valued at \$277 million. According to the U.S. Bureau of Mines, projected from third-quarter figures, 1994 production will increase by just over 10%.

In 1992, according to Rock Products magazine, four of the nation's top 20 crushed-stone plants were located in Texas, namely the Redland Worth Corporation's Beckman limestone quarry operation in Bexar County, Texas Crushed Stone's Georgetown limestone plant in Williamson County, Parker-Lafarge Corporation's New Braunfels limestone operation in Comal County, and the Bridgeport limestone plant of Texas Industries Inc. in Wise County (Fig. 5). Vulcan Materials Company is the largest producer in Texas with plants in Bexar, Brown, Eastland, Grayson, Kerr, Parker, Taylor, Uvalde, and Wise Counties, located mainly in north-central through southwest Texas.

### Dimension stone

In 1992, Texas ranked fourth out of 34 states producing dimension stone. Granite and limestone currently are the primary sources of production; only a small amount of sandstone is presently produced in Texas (Fig. 6).

Granite—Granite production is in central Texas, primarily Burnet, Gillespie, Llano, and Mason Counties (Garner, 1992). Quarries are primarily in the large Town Mountain Granite bodies of Precambrian age.

In 1992, Texas Granite Corporation, a subsidiary of Cold Spring Granite Company, unveiled their newest color, "Azalea," which was reportedly similar to the "Sunset Red" color but featured deeper red hues. This variety of granite is utilized in a monument dedicated to Sam Houston and located near his birthplace in Lexington, Virginia (Fig. 7).

Premier Granite Quarries Company produces granite from two quarries in Llano County. The unique dark pink

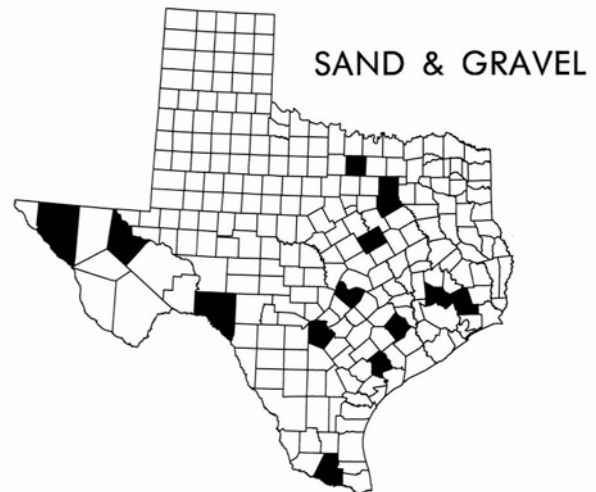

FIGURE 4—Construction-sand-and-gravel-producing counties in Texas.

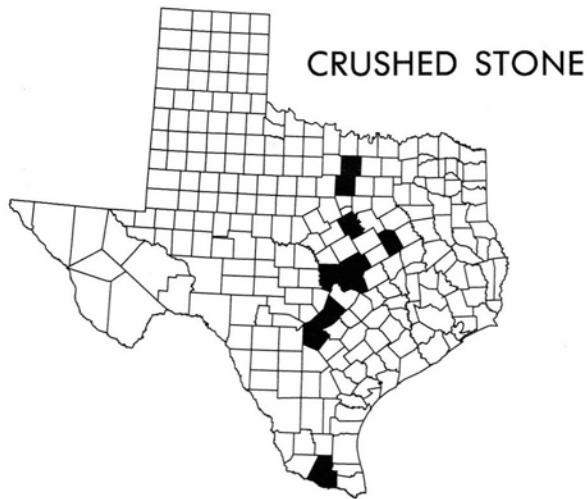

FIGURE 5—Crushed-stone-producing counties in Texas.

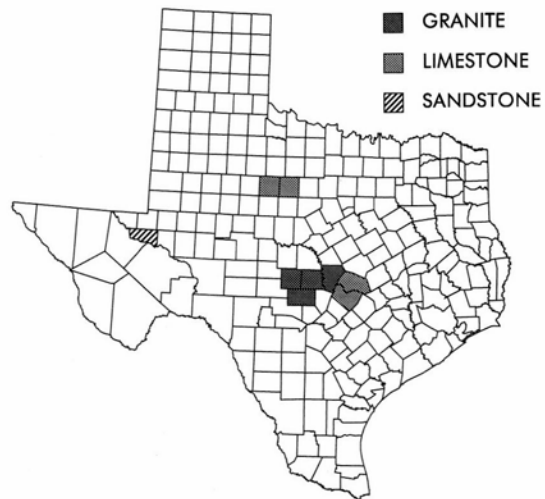

FIGURE 6—Dimension-stone-producing counties in Texas.

granite (lanite) variety, which contains sky-blue quartz crystals is an important exported industrial mineral. In September 1994 Premier was quarrying coarse pink granite from two separate quarries; the rough stone was transported to Houston and most of it exported to Taiwan.

**Limestone**—Limestone production is from the Lueders Formation of Permian age in Jones and Shackelford Counties and from the Walnut Formation of Cretaceous age in Travis and Williamson Counties (Garner, 1992).

The Lueders Formation in north-central Texas is a medium- to light-gray, fossiliferous calcarenite with some interbedded shale. Two types of dimension stone are produced from the cream-colored and relatively soft limestones of the Walnut Formation in Travis and Williamson Counties in central Texas. One type is a fine- to medium-grained limestone originally marketed as "Austin Stone" but presently called "Cordova Cream." The other type, a highly fossiliferous limestone, is marketed as "Cordova Shell."

Featherlite Building Products Corporation, a subsidiary of Justin Industries Inc., produces a cream-colored, oolitic limestone at their Texas Quarries operation at Cedar Park. Texas Quarries also operates a quarry in Jones County, near Abilene, from where the dimension stone is exported all over the world but predominantly to Japan. Dimension stone is also marketed locally through Featherlite's homebuilding stores.

**Sandstone**—Dimension sandstone is produced from the Dockum Group of Triassic age in Ward County, west Texas. The hematitic, fine- to medium-grained red sandstones are presently used to refurbish old buildings near San Antonio.

Supplies of dimension stone in Texas are unlimited. Exports of stone from the ports in Texas are mainly to Japan (limestone), Taiwan (granite) and Canada. Imports of dimension stone increased by six times in the 1980s, with more than 60% coming from Italy.

#### Fuller's earth

Texas ranked 10th out of 11 states producing fuller's earth in 1992. The fuller's earth (actually a calcium bentonite) is produced by only two companies, Mid-Tex Minerals Inc. and Balcones Mineral Corporation, both in Fayette County between Houston and Austin (Fig. 3). The product is marketed to manufacture oil and grease absorbent, pet-waste absorbent, and electronic porcelain.

#### Gypsum

Texas produces both crude and by product gypsum; in 1993 production of crude gypsum was 1,696,000 mt at a value of \$10,355,000. The state ranked third in crude-gypsum output and second in output of byproduct gypsum.

U.S. Gypsum Company's Sweetwater operation in Nolan County, just west of Abilene, is the largest gypsum producer in Texas, and their wallboard plant is the third largest in the United States (Fig. 8). The Galena Park facility of U.S. Gypsum Company in Harris County, just east of Houston, is the only operation that is producing gypsum as a byproduct.

National Gypsum Company mines gypsum in both Kimble (south of Abilene and west of Austin) and Stonewall (north of Abilene) Counties and operates a wallboard plant in Fisher County northwest of Abilene. Georgia Pacific Corporation operates a quarry and wallboard plant in Hardeman County in northern Texas near the Oklahoma border. Standard Gypsum Company quarries gypsum in Gillespie County west of Austin and operates a wallboard plant in Guadalupe County south of Austin.

Gypsum is currently imported through the port of Houston from Jamaica (58,887 mt in 1993) and a minor tonnage from Germany. Crude gypsum is exported through Freeport (40 mt to Honduras), Galveston (150 mt to France, Italy, Tunisia, and the United Kingdom),

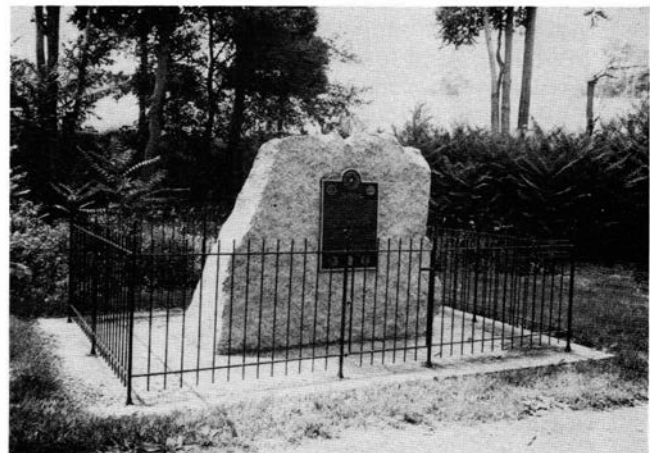

FIGURE 7—Granite memorial to Sam Houston near Lexington, Virginia.

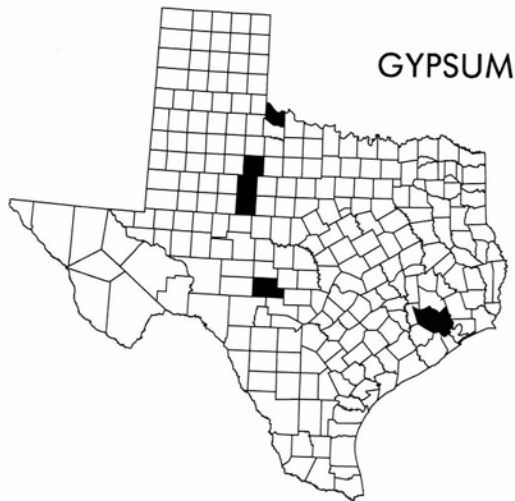

FIGURE 8—Gypsum-producing counties in Texas.

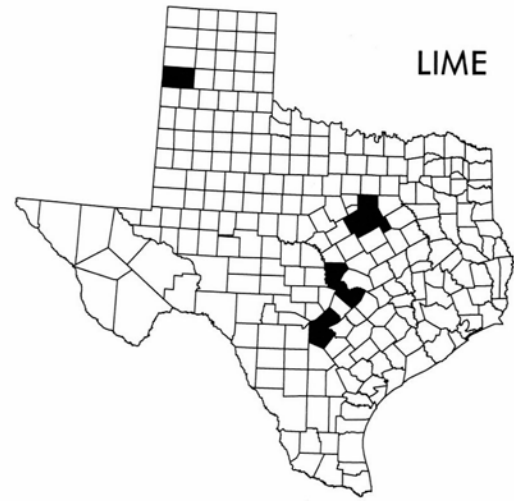

FIGURE 9—Lime-producing counties in Texas.

and Houston (more than 250 mt in 1993 to Belgium, Ecuador, Egypt, Hong Kong, Panama, Saudi Arabia, the United Kingdom, and Venezuela).

#### Industrial sand

Texas ranks fifth of 38 states that reported production of industrial sand in 1992. Industrial sand totaling 1.28 million mt (valued at \$26,427,000) was produced in McCulloch, Johnson, and Limestone Counties by Barry and Barry Sand Company Inc., Oglebay Norton/Texas Mining Company, Pioneer Concrete of Texas Inc., Unimin Corporation, US Silica Company, and Vulcan Materials Company. The Oglebay Norton operation in McCulloch County reported 63 years of reserves in 1993.

Main uses for industrial sand produced in Texas are for container manufacturing, blasting sand, molding sand, and frac (hydrofracture) sand. Sales of frac sand increased toward the end of the year due to increased drilling activity.

#### Kaolin

Kaolin (china clay) is produced only by US Silica Co. as a coproduct from kaolinitic sandstone, and is mined in Limestone County southeast of Dallas (Fig. 3). The State ranks third in the country by output value. Most of the kaolin is used to make paint, with minor amounts used to make pottery and as a binder in animal feed.

Kaolin (549 mt) is imported through Houston from the United Kingdom and Spain. Large tonnages are exported through Galveston (113 mt) to Colombia and Republic of South Africa, and through Houston (1,810 mt) to Bolivia, Chile, Italy, Japan, Republic of South Africa, Spain, Sweden, Taiwan, Thailand, and Venezuela.

#### Lime

In 1993, 1,337,000 mt of lime at a value of \$83,359,000 were produced by six companies in Texas. The leading lime producer is Chemical Lime Group's Clifton plant in Bosque County south of Dallas, which is the seventh largest producer in the United States (Fig. 9). The other five major Texas producers are APG Lime in Comal County, Austin White Lime Company and Redland PLC in Travis County, Holly Sugar Corporation in Deaf Smith County, and Texas Lime Company in Johnson County (Fig. 9).

Austin White Lime Company quarries the Edwards Formation of Early Cretaceous age. In the Travis County area

the Edwards Formation is a fine- to coarse-grained, shelly limestone up to 91 m thick.

Texas Lime Company quarries the Edwards Formation in Johnson County to the northwest. Here the limestone is very pure but usually less than 15 m thick. McBride et al. (1992) estimate that 6.6 trillion mt of Edwards and assorted limestones crop out in Texas.

#### Salt

Texas produced 9,055,000 mt of salt in 1993, valued at \$75,707,000. The state ranked second in salt production but only sixth value-wise during the year. The major producers along the southeast coast of Texas are Morton International in Van Zandt County, Oxy Chemical in Chambers County, and Texas Brine Corporation in Jefferson, Matagorda, and San Patricio Counties (Fig. 10). Salt is produced from salt domes or pillars that have intruded sedimentary rocks. Salt at Grand Saline in Van Zandt County east of Dallas is a gray-to-bluish aggregate of halite crystals and contains dark bands of anhydrite and many other minerals, including trace amounts of dolomite, calcite, and quartz.

#### Sulfur

Sulfur in Texas is produced from the caprock of salt domes by injecting hot water into the deposit through

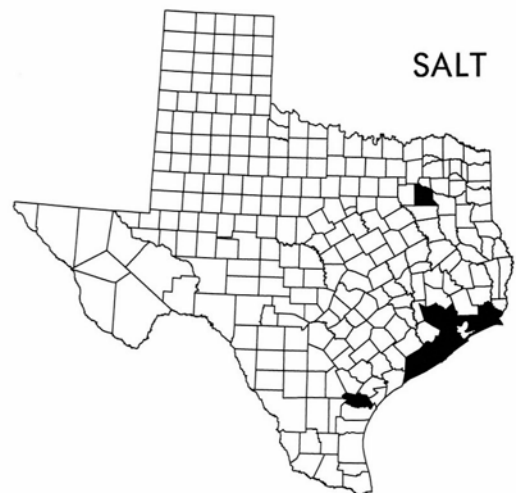

FIGURE 10—Salt-producing counties in Texas.

wells and recovering the sulfur in molten form (Frasch process). Frasch sulfur production in 1993 was only 1,265,000 mt by two companies. Pennzoil Sulphur Company a subsidiary of Pennzoil Company (now Freeport Sulphur Company, a subsidiary of Freeport—McMoran), mined sulfur in Culberson County near Orla east of El Paso (Fig. 11). Because of decreasing prices in 1993, the company attempted a new mining method reducing energy costs by continuous reinjection. In this process water is heated about 400 m away instead of pumping it from a distance of about 3 km as in the old process. In 1992 78% of the product was sold to the phosphate industry for use in making phosphate fertilizer. Texasgulf Inc. (subsidiary of Nationale Elf Aquitaine) mined Frasch sulfur at their Newgulf mine in Wharton County southwest of Houston (Fig. 11).

Prices of sulfur have decreased the last few years due to an increase in Canadian exports at discounted prices (from extraction of sulfur from sour gas), a sharp decrease in consumption from several export markets, and because of an increase in recovered-sulfur production.

The largest end use of sulfur has been in sulfuric-acid plants feeding agricultural chemical-production processes including phosphatic and nitrogenous fertilizers, pesticides, animal feeds, and other agricultural chemicals. Consumption of sulfur has tended to increase recently in drugs and food products, soaps, detergents, and water treatment, and acid-storage batteries. A downward trend occurred in paints and explosives, and no changes were noted in plastics and synthetics (Ober, 1993).

### Talc

During 1993, 222,300 mt of black talc valued at \$4,900,000 were produced by five companies in Culberson and Hudspeth Counties in west Texas (Dupree, 1993). The five companies that mine the impure talc near Van Horn include Dal Minerals Company (a subsidiary of Dal-Tile Corporation), United Clay of Texas Inc. (a subsidiary of Watts Blake Bearne and Company PLC), Milwhite Inc., Pioneer Talc Company, and Apache Minerals Inc.

More than 80% of the talc produced is sold for use in ceramic tiles; it is also utilized as a filler in paint, paper, plastic, refractory materials, and rubber (Dupree and Garner, 1992). Talc was imported through the deepsea

(202 mt) and intercoastal (7,754 mt) ports at Brownsville in 1993 and 1994 (through June).

### Zeolites

In 1992, Texas was the leading state (out of seven) in production of zeolites (hydrated aluminosilicates). Zeotech Corporation mined clinoptilolite from its Tilden pit in McMullen County south of San Antonio. The Tilden deposit is in a tuff in Jackson Group of Eocene age. Production is customer-oriented and markets are for animal-waste absorbent and various filtration uses. The product is bagged and trucked to market.

In 1992 AKZO Chemicals Inc. built their second plant in Pasadena, a suburb of Houston, to produce synthetic zeolites. The company had already renovated an old plant site in 1985. In 1994 the company, now AKZO Nobel, plans a third plant site. AKZO Nobel produces synthetic zeolites from a hydrous metal aluminosilicate mixture for a growing refinery market, especially in the southeast Texas area. Synthetic zeolites have larger void spaces than natural zeolites and are used as a site for "cracking" gas—oil molecules. Materials such as water, carbon dioxide, sulfur dioxide, paraffin, alcohol are absorbed during this process. In catalytic cracking catalysts containing polyvalent ion-exchange x or y exhibit higher activity and up to 20% higher gasoline yields are obtained (Breck, 1983). Thirty to forty different catalysts are used in the petroleum industry in producing different grades of gasoline. AKZO's product is sold in bulk bags distributed by rail all over the United States. Chevron Resources Company and Shell Oil Company in El Paso are two of AKZO's customers.

As for natural zeolites, another deposit is present near Coy City in Karnes County. Also this deposit is in tuff and tuffaceous sandstone of the Jackson Group. There is an occurrence of analcime zeolite near Terlingua in Brewster County southeast of El Paso, which is in the black Tarry Shale of late Mesozoic age.

### References

- Breck, D. W., 1983, Synthetic zeolites: Properties and applications in Lefond, S. J. (ed.), *Industrial minerals and rocks*, 5th ed.; Society of Mining Engineers of the American Institute of Mining, Metallurgical, and Petroleum Engineers Inc., New York, pp. 1399-1413.
- Dupree, J. A., 1993, *The mineral industry of Texas in 1993*: U.S. Bureau of Mines, Mineral Industry Survey, 4 pp.
- Dupree, J. A., and Garner, L. E., 1992, *The Mineral industry of Texas*; in *Minerals Yearbook*, Vol. II: U.S. Bureau of Mines, p. 523-540.
- Garner, L. E., 1992, *The dimension stone industry of Texas*: University of Texas (Austin), Bureau of Economic Geology, Mineral Resource Circular 82, 16 pp.
- McBride, M. W., Patty, T. S., and Sharpe, R. D., 1992, *Texas Portland cement industry and cement resources*: University of Texas (Austin), Bureau of Economic Geology, Mineral Resource Circular 83, 73 pp.
- Ober, J. A., 1993, Sulfur in chemical industry applications of industrial minerals and metals: U.S. Bureau of Mines, Special Publication, pp. 125-127.
- Olson, R. H., 1983, Zeolite—Introduction; in Lefond, S. J. (ed.), *Industrial minerals and rocks*, 5th ed.; Society of Mining Engineers of the American Institute of Mining, Metallurgical, and Petroleum Engineers Inc., pp. 1,391-1,399.
- Stenzel, H. B., 1950, *Ball clay of the Trup District, Texas*: University of Texas, Publication no. 5019, 37p.

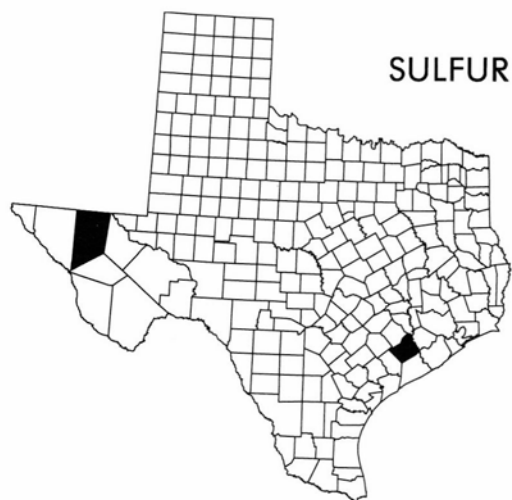

FIGURE 11—Sulfur-producing counties in Texas.

# Overview of the Carlsbad potash district, New Mexico

James M. Barker and George S. Austin

*New Mexico Bureau of Mines & Mineral Resources, New Mexico Tech, 801 Leroy Place, Socorro, New Mexico 87801-4796, USA*

**Abstract**—Potash is the common industrial term for potassium in various chemical combinations with sodium, magnesium, chloride, and sulfate. In New Mexico, the important natural, commercial, soluble potassium salts are sylvite (KCl) and langbeinite ( $K_2SO_4 \cdot 2MgSO_4$ ). Sylvinite, a mixture of sylvite and halite, is the typical ore mined in the Carlsbad potash district (CPD) in southeastern New Mexico. The Potash Enclave, also designated the Known Potash Leasing Area (KPLA), consists of that part of the district where federal and state lands require competitive bidding, under BLM management, for mineral leases.

Potash-bearing evaporites occur in Ochoan (Upper Permian) marine rocks in the Delaware Basin portion of the Permian Basin of west Texas and southeast New Mexico. The Ochoan is divided into four formations, of which the second oldest—the Salado Formation—contains mineable potash. The Salado, up to a maximum of 670 m thick, is an evaporite sequence dominated by 200-400 m of halite and muddy halite in the KPLA. It hosts 12 ore-bearing zones; 11 in the middle or McNutt Member, and one in the upper member. The area underlain by the 12 zones is about 4,920 km<sup>2</sup>. The McNutt Member of the Salado Formation dips about 1° to the east within the district and is about 120 m thick.

Potash ore zones are 1-3 m thick and are laterally consistent except where interrupted by salt horses, collapse features, and igneous dikes. Commercial deposits were created in some localities by magnesium-undersaturated fluids moving through the zones, but in other areas late fluids dissolved ore, producing barren halite (salt horses). The McNutt Member is absent in the subsurface due to solution just west of the present mines. A typical mixed ore from the Salado in the district contains 60% halite and 30% sylvite (usually together as sylvinite), with 5% langbeinite, 2% polyhalite, and 2% insolubles.

The high solubility of most potash ores limits them to the subsurface, hence all mines in the district are underground. Mine depths range from about 270 to 425 m. These room-and-pillar mines are relatively clean, dry, and orderly because the beds being exploited are relatively shallow, regular, tabular, and nearly flat. Room-and-pillar mining is flexible and allows selective mining. Continuous mining equipment adapted from coal mining is used to mine most potash ore although blasting is increasingly used. Beds as thin as 1.2 m are mined with mechanical drum miners. Some harder ores, particularly langbeinite, require mechanical undercutters to prepare the working face for drilling and blasting, usually with ANFO (ammonium nitrate and fuel oil). Mechanical miners for langbeinite are under development to reduce blasting and mining cost.

Mills in the district produce potash by combinations of separation, flotation, crystallization, leaching, and heavy-media circuits related to a specific ore. Output from these circuits is dried in fluid bed or rotary dryers and sized over screens to yield final products. Potash ore is ground to break up sylvite-halite agglomerates followed by froth flotation. The abundance and mineralogy of clay minerals are significant in processing potash ores, in particular, the clay-rich 10th ore zone, because slimes are deleterious.

Potash tailings in the CPD, largely halite and clay, are stored or disposed of on the surface. Solid wastes are piled and monitored for salt leakage, which is minimal owing to the semi-arid climate. Brines are evaporated in impoundments or in a natural saline lake.

## Reseña de los yacimientos de potasa, distrito de Carlsbad, Nuevo Mexico

**Resumen**—El término "potasa" es usado en la industria para el potasio en varias combinaciones químicas con sodio, magnesio, cloruro y sulfato. En Nuevo México, las importantes sales naturales y solubles de potasio que se comercializan son la silvina (KCl) y la langbeinita ( $K_2SO_4 \cdot 2MgSO_4$ ). Silvinita, una mezcla de silvina y halita, es el mineral típico explotado en el Distrito de Carlsbad en el sureste de Nuevo México. El "Reducto de la Potasa" (*Known Potash Leasing Area [KPLA]*), así llamado, es una parte del distrito de Carlsbad donde los permisos de explotación mineral en tierras federates o estatales se otorgan por medio de licitación pública, administrada por la Oficina Federal de Tierras (*Bureau of Land Management [BLM]*).

Evaporitas potásicas ocurren en rocas marinas de edad Ochoaniense (Pérmico superior) en la Cuenca de Delaware, la cual es parte de la Cuenca Pérmica del oeste de Texas y el sureste de Nuevo México. El Ochoaniense se divide en cuatro formaciones, de las que la segunda de abajo, la Formación Salado, contiene sales de potasio explotables. La Formación Salado consiste de una sucesión evaporítica que alcanza hasta 670 metros de espesor y en el KPLA está dominada por 200 a 400 metros de halita y halita barrosa. Contiene 12 zonas de grado explotable, 11 de ellas se



encuentran en el miembro intermedio, *McNutt*, y la restante está en el miembro superior. Estas 12 zonas cubren un área de más o menos 4,900 km<sup>2</sup>. En este distrito, el *Miembro McNutt* tiene un buzamiento de alrededor de 1° hacia el este y su espesor es de unos 120 metros.

Las zonas de grado comercial tienen espesores de 1 a 3 metros y son continuas lateralmente, excepto donde hay interrupciones estructurales: "caballos" de halita, estructuras de colapso y diques igneos. En algunas localidades se formaron depósitos comerciales por infusión de fluidos subsaturados en magnesio; pero en otras áreas, fluidos tardíos disolvieron las sales de potasio produciendo halita estéril (*caballos de sal*). Al oeste de las minas actuales, el *Miembro McNutt* está ausente en el subsuelo porque ha sido disuelto. Una típica mena mixta de la Formación Salado en el distrito contiene 60% de halita y 30% de silvina (que frecuentemente ocurren juntas en la forma de silvinita), 5% de langbeinita, 2% de polihalita y 2% de insolubles.

Debido a su alta solubilidad, la mayoría de las sales potásicas sólo se conservan en el subsuelo, por lo que todas las minas son subterráneas. Su profundidad varía entre los 270 y 425 metros. La extracción se hace en forma de cuarto-y-columna (*room-and-pillar*) y estas minas son relativamente limpias, secas y regulares porque los mantos son relativamente poco profundos, continuos, de espesor uniforme y casi horizontales. Este método de extracción, cuarto-y-columna, es flexible y permite una extracción selectiva. En la mayoría de las operaciones se usa maquinaria de extracción continua, adaptada de la minería del carbón, aunque el uso de explosivos va en aumento. Mantos con un espesor de solamente 1.2 metros son explotados con máquinas de extracción continua (*drum miners*). Ciertas menas más duras, especialmente las que contienen langbeinita, requieren socavadoras mecánicas que preparan el frente de trabajo para barrenar y dinamitar, generalmente con ANFO (nitrato de amonio con petróleo). Para reducir los costos de extracción se están desarrollando máquinas de extracción continua para la langbeinita.

Plantas concentradoras en el distrito producen potasa comercial combinando procesos de separación, flotación, cristalización y lixiviación. Se usan líquidos pesados para ciertos tipos de mena. Después de pasar por estos circuitos, el concentrado es secado en secadoras de lecho fluido o rotatorias. Luego es tamizado para obtener los productos finales. La mena de potasa es molida para deshacer los agregados de silvina-halita, y luego se la pasa por un circuito de flotación espumosa. La abundancia y mineralogía de las arcillas es importante en el procesamiento de menas de potasa. Esto es el caso especialmente en la zona décima donde hay abundancia de arcillas; las arcillas forman un precipitado viscoso que inhibe el proceso de concentración.

Los residuos de la extracción de potasa en el Distrito de Carlsbad consisten mayormente de sal (halita) y arcilla y son amontonados en la superficie. Un sistema de control ambiental mide la infiltración de salmueras de los desmontes, que es mínima gracias al clima semiárido. Las salmueras se almacenan y evaporan en estanques o en un lago salado natural.

### Introduction

Potash is the common industrial term for potassium in various chemical combinations with sodium, magnesium, chloride, and sulfate (Table 1). Potash was a term originally applied to potassium carbonate and potassium hydroxide recovered in iron "pots" from washings of wood "ash" (Searls, Copeland, and Woodson, 1995). Potassium is one of the three essential plant nutrients and is the "K" in the "NPK" fertilizer rating along with nitrogen (N) and phosphorus (P). The potassium in potash is reported as ISO eq. wt.% (% K<sub>2</sub>O hereafter), although potassium oxide is not directly present in natural potassium salts (Table 2). For potash fertilizers, K<sub>2</sub>O is closest chemically to the form of potassium used by plants (Sullivan and Michael, 1986) and is the best means to compare the diverse mineralogy of potash.

Important natural, commercial, soluble potassium salts are sylvite and langbeinitite. Sylvinitite, a mixture of sylvite and halite, is the typical ore mined in the CPD in southeastern New Mexico (Fig. 1). The CPD is near the northeastern border of the Delaware Basin (Fig. 1) and contains the largest domestic potash reserves. Soluble potash occurs primarily in Eddy and Lea Counties, which contain the only potash mines in the state. The Potash Enclave (Fig. 2), also designated the KPLA consists of that part of the CPD where federal and state lands require competitive bidding, under BLM management, for mineral leases. The WIPP site is on the southeastern edge of the KPLA (Fig. 2) in secs. 15-22 and 27-34 T22S R31E (Fig. 2).

The KPLA lies between Carlsbad and Hobbs, NM, and includes about 1,100 hectares (Cheeseman, 1978; Barker and Austin, 1993). The area underlain by other salts and less soluble potash minerals, such as polyhalite, is much

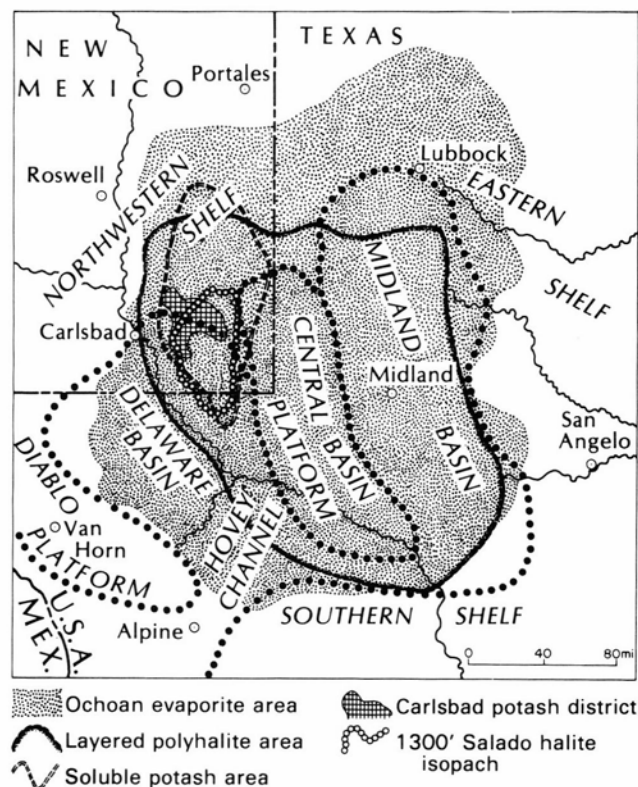

FIGURE 1—Location of the Carlsbad Potash District in the southwestern United States and its relation to the regional subsurface geology.



TABLE 1—Evaporite minerals and rocks of the Carlsbad Potash District. After Griswold, 1982. Only sylvite and langbeinite are presently ore minerals. Hydrated potassium minerals are not amenable to existing concentration methods.

Mineral or rock	Formula	Equivalent wt. %			
		K	KCl	K <sub>2</sub> O	K <sub>2</sub> SO <sub>4</sub>
Anhydrite*	CaSO <sub>4</sub>	—	—	—	—
Arcanite	K <sub>2</sub> SO <sub>4</sub>	44.88	—	54.06	100.00
Bischofite	MgCl <sub>2</sub> ·6H <sub>2</sub> O	—	—	—	—
Bloedite	Na <sub>2</sub> SO <sub>4</sub> ·MgSO <sub>4</sub> ·4H <sub>2</sub> O	—	—	—	—
Carnallite*	KCl·MgCl <sub>2</sub> ·6H <sub>2</sub> O	14.07	26.83	16.95	—
Erytrosiderite	2KCl·FeCl <sub>3</sub> ·H <sub>2</sub> O	23.75	45.28	28.61	—
Glaserite	K <sub>3</sub> Na(SO <sub>4</sub> ) <sub>2</sub>	35.29	—	42.51	78.63
Glauberite	Na <sub>2</sub> SO <sub>4</sub> ·CaSO <sub>4</sub>	—	—	—	—
Gypsum*	CaSO <sub>4</sub> ·2H <sub>2</sub> O	—	—	—	—
Halite*	NaCl	—	—	—	—
Hydrophilite	KCl·CaCl <sub>2</sub> ·6H <sub>2</sub> O	13.32	25.39	16.04	—
Kainite*	MgSO <sub>4</sub> ·KCl·3H <sub>2</sub> O	15.71	29.94	18.92	—
Kieserite*	MgSO <sub>4</sub> ·H <sub>2</sub> O	—	—	—	—
Langbeinite*	K <sub>2</sub> SO <sub>4</sub> ·2MgSO <sub>4</sub>	18.84	—	22.70	41.99
Leonite*	K <sub>2</sub> SO <sub>4</sub> ·MgSO <sub>4</sub> ·4H <sub>2</sub> O	21.33	—	25.69	47.52
Mirabilite	Na <sub>2</sub> SO <sub>4</sub> ·10H <sub>2</sub> O	—	—	—	—
Polyhalite*	K <sub>2</sub> SO <sub>4</sub> ·MgSO <sub>4</sub> ·2CaSO <sub>4</sub> ·2H <sub>2</sub> O	12.97	—	15.62	28.90
Schoenite	K <sub>2</sub> SO <sub>4</sub> ·MgSO <sub>4</sub> ·6H <sub>2</sub> O	19.42	—	23.39	43.27
Sylvinite*	KCl + NaCl	—	—	—	—
Sylvite*	KCl	52.44	100.00	63.17	—
Syngenite	K <sub>2</sub> SO <sub>4</sub> ·CaSO <sub>4</sub> ·H <sub>2</sub> O	23.81	—	28.68	53.06
Tachyhydrite	CaCl <sub>2</sub> ·2MgCl <sub>2</sub> ·12H <sub>2</sub> O	—	—	—	—

\*Common minerals and rocks in the Carlsbad Potash District.

TABLE 2—K<sub>2</sub>O equivalent wt.% of commercial potash minerals. After Searls, 1985; Adams and Hite, 1983; and Sullivan and Michael, 1986.

Chemical compound	Chemical formula	Mineral name	Industry name	Max K <sub>2</sub> O eq. wt%	Grades K <sub>2</sub> O eq. wt. %	Remarks
Potassium chloride	KCl	Sylvite	MOP, sylvite, muriate	63.18	61 (USA) 60 50 40 30 } World	Coarse grades used to match sizes of N-P ingredients to minimize segregation
Potassium chloride + sodium chloride	KCl+NaCl	"Sylvinite"	—	≈35	—	Easily mined with continuous miners
Potassium/magnesium double sulfate	2MgSO <sub>4</sub> ·K <sub>2</sub> SO <sub>4</sub>	Langbeinite	SOPM, sulfate of potash magnesia	22.70	22 21.5	Preferred for tobacco, paper, potato, sugar beet, and citrus crops to prevent chloride burn; harder to mine than chlorides
Potassium sulfate	K <sub>2</sub> SO <sub>4</sub>	Arcanite	SOP	54.06	50	Preferred for tobacco, paper, potato, sugar beet, and citrus crops to prevent chloride burn; mostly manufactured, some is natural
Potassium nitrate	K <sub>2</sub> NO <sub>3</sub>	Nitre	—	—	—	Natural is only 14% K <sub>2</sub> O (admixture) crude salt mixed with NaNO <sub>3</sub> ; mostly manufactured, some is natural
Potassium chloride	KCl	Manure salts	—	19	—	Manufactured

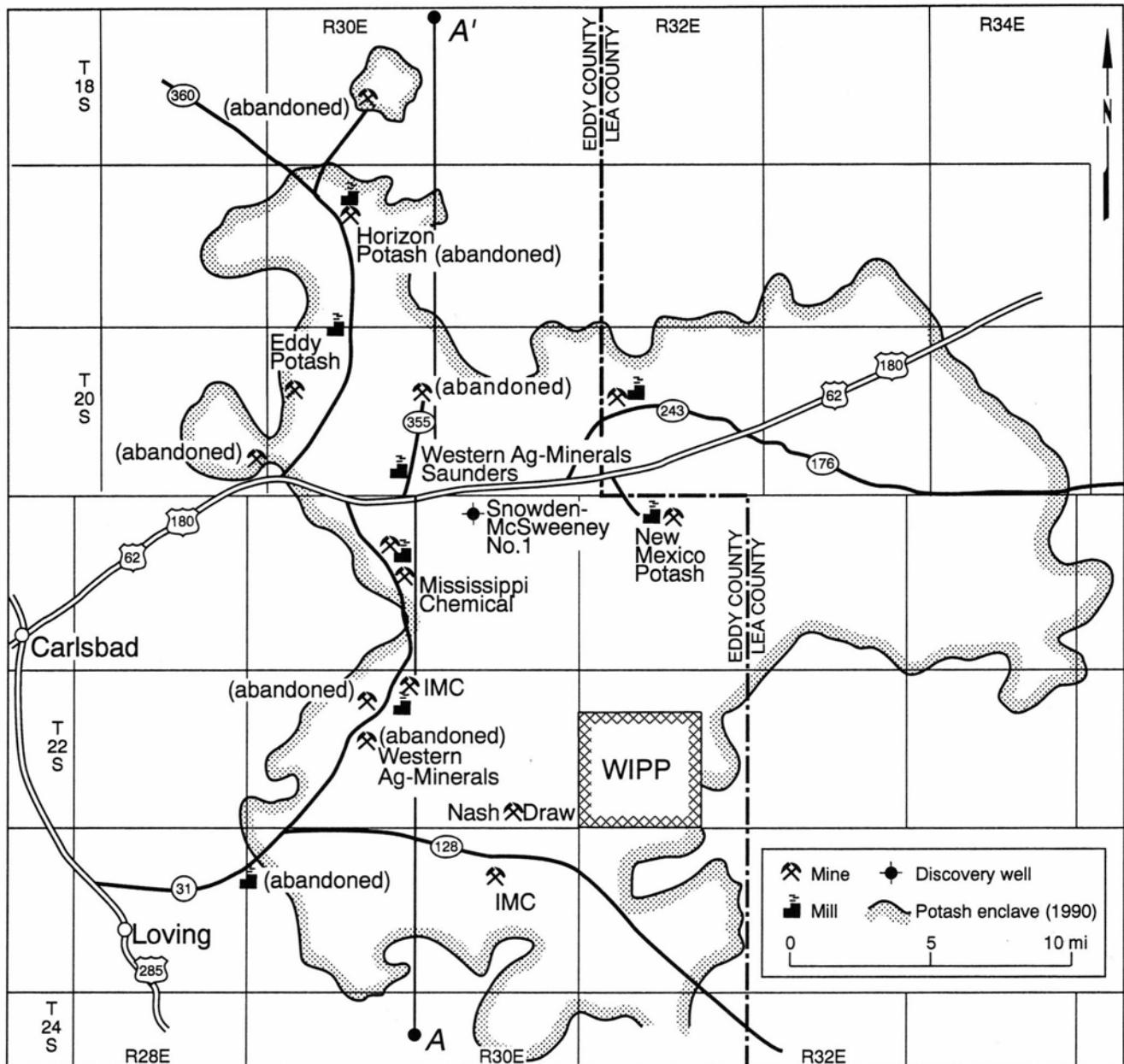

FIGURE 2—Active, inactive, and abandoned potash facilities in Eddy and Lea Counties, southeastern New Mexico, showing general outline of the Potash Enclave (KPLA) as of 1984.

larger than the KPLA (Fig. 1). The Salado Formation underlies about 150,000 km<sup>2</sup>, halite about 96,000 km<sup>2</sup> and polyhalite about 70,000 km<sup>2</sup> (Jones, 1972). Areal limits of the CPD are determined by drilling to the north, east, and south. The CPD is bounded on the west by dissolution truncation of shallow Salado evaporites caused by circulating groundwater in the Pecos River drainage basin (Griswold, 1982).

Potassium products (Table 2) from New Mexico are muriate of potash (potassium chloride, KCl; also called MOP, muriate, or sylvite by industry), langbeinite (potassium magnesium sulfate, K<sub>2</sub>SO<sub>4</sub>·2MgSO<sub>4</sub>; called sulfate of potash magnesia or SOPM), and manufactured potassium sulfate (K<sub>2</sub>SO<sub>4</sub>; called sulfate of potash or SOP). MOP, sold in various grades (Table 3), comprises about 70% of New Mexico potash output; SOPM and SOP account for the remaining 30%. IMC Global (IMC), the largest producer in the CPD, supplies all three types of soluble

potash salts (Table 2); other producers are more specialized.

The United States ranked fourth in world potash production at 1.42 million metric tons (mt) in 1994 (Searls, 1994). New Mexico, which accounted for about 81% of domestic production (1.15 million mt), supplied about 21% of domestic consumption (Table 4), and has about 57% of domestic reserves (Searls, Copeland, and Woodson, 1995; Searls, 1993). The remaining 79% of consumption was imported primarily from Saskatchewan, Canada (91%). Domestic potash production is composed of about 75% as muriate, 20% as sulfate or langbeinite, and 5% in other forms (Searls, 1993). About 95% of soluble potash minerals are used in fertilizer, so potash trends closely parallel agricultural supply and demand during crop years (Searls, 1993). Most of the additional 5% is used in chemicals (O'Driscoll, 1990), mainly aqueous electrolysis of potash to potassium hydroxide. Potassium chemi-

TABLE 3—Particle-size grades of muriate of potash (MOP, muriate, sylvite), langbeinite (SOPM), and sulfate of potash (SOP) products. After Searls, 1985. NA = not applicable.

Grade	Minimum K <sub>2</sub> O equiv. wt.%	Approximate particle size range <sup>1</sup>		Type of potash	Remarks
		Mesh <sup>2</sup>	Millimeters		
Granular	61, 50, 22	6–20	3.35–0.85	Muriate & sulfate	—
Blend <sup>3</sup>	60	6–14	3.35–1.18	Muriate and coarse grades	Replaces granular
Coarse	60	8–28	2.4–0.6	Muriate	—
Standard	60, 50, 22	14–65	1.2–0.21	Muriate & sulfate	—
Special standard Soluble/suspension	60	35–150	0.4–0.11	Muriate & sulfate	Canada only
Chemical	62	35–150	0.4–0.11	Muriate	—
	63	NA	NA	Muriate	—

<sup>1</sup>From approximately 2–98% by wt.% cumulative.

<sup>2</sup>Tyler standard.

<sup>3</sup>Blend = new grade with midpoint between 8 and 10 mesh introduced by Canadian producers.

cals are used in medicines, pharmaceuticals, salt substitutes, soap, matches, glass, storage batteries, and other uses.

The weighted average annual price for domestic potash sales (all types and grades) in 1994 was \$193.23 per mt (FOB mine). The average annual price for KCl (standard, coarse, granular) was \$131.01 per mt (Searls, Copeland, and Woodson, 1995).

#### Brief history of potash development

The following discussion of potash mining history draws heavily on Walls (1985) and Williams-Stroud et al. (1994). Early large-scale use of potash started in Germany in the mid-19th century. The modern United States potash industry is primarily a product of a World War I (WWI) embargo on German potash—the only large source then known—that drove prices to over \$550 /mt. Wartime potash (for saltpeter manufacture) was produced at over 100 plants, mainly in Nebraska and California, each with very small output. Bedded potash was discovered in 1925 in Eddy County, New Mexico, in Snowden McSweeney Well No. 1 on a V. H. McNutt permit near the center of the KPLA now mined (Fig. 2; T21S R30E).

Potash was cored in April 1926, and the Federal Potash Exploration Act was passed in June.

The American Potash Company was formed in 1926 for potash exploration in southeastern New Mexico. A 324 m shaft was started in December 1929 and completed in 1930. The first commercial potash from New Mexico was shipped in March 1931, 12 years after WWI. Assets of American Potash, incorporated in 1930 as United States Potash Company, are now owned by Mississippi Chemical. The Potash Company of America (PCA) was formed in 1931 and completed a shaft in early 1934. The Santa Fe Railroad constructed a 32 km spur from Carlsbad to the mine; later spurs were run to other mines and mills. The PCA mine is now operated by Eddy County Potash. By 1934 at least 11 companies were exploring for potash in southeastern New Mexico. In 1936, Union Potash & Chemical, Texas Potash, Independent Potash & Chemical, New Mexico Potash, and Carlsbad Potash merged into what is now IMC and began producing sylvite, langbeinite, and K<sub>2</sub>SO<sub>4</sub> in 1940.

Domestic production supplied virtually all potash in the United States between 1941 and 1949. New Mexico produced about 900,000 mt of marketable potash contain-

TABLE 4—Potash statistics for calendar years 1980 to 1994. Data modified from J. P. Searls, U.S. Bureau of Mines, oral commun., June 1990, June 1993, and January 1995, and U.S. Bureau of Mines Mineral Commodity Reports, Mineral Commodity Profiles, Mineral Industry Surveys, and Mineral Yearbooks (1980–1995). NA—Not available.

Calendar year	Marketable U.S. production (1000 mt K <sub>2</sub> O)	Apparent U.S. consumption (1000 mt K <sub>2</sub> O)	Net U.S. import reliance (%)	N.M. share of U.S. production (%)	N.M. supply to U.S. consumption (%)	Avg. price NM marketable potash (\$/mt K <sub>2</sub> O)	Value NM production of marketable potash FOB mine (million \$)
1980	2,239	6,349	65	83	29	\$160	289
1981	2,156	6,213	65	84	29	\$172	261
1982	1,784	5,123	65	82	29	\$149	205
1983	1,429	5,653	75	87	22	\$146	175
1984	1,564	6,022	74	90	23	\$148	204
1985	1,296	5,346	76	87	21	\$141	156
1986	1,202	4,843	75	82	20	\$127	133
1987	1,262	5,088	75	87	22	\$132	174
1988	1,521	5,264	71	89	26	\$169	214
1989	1,595	5,151	65	89	31	\$176	243
1990	1,713	5,410	68	89	28	\$176	246
1991	1,749	5,243	68	85	28	\$179	251
1992	1,705	5,330	68	83	27	\$177	257
1993	1,506	5,432	72	82	23	\$181	216
1994	1,425	5,390	74	81	21	NA	NA

ing 475,000 mt of  $K_2O$  in 1941. New Mexico was the largest domestic potash producer in 1944, furnishing 85% of consumption. Active exploration by several companies in 1949 resulted in production in 1951 by Duval Texas Sulfur via two mine shafts at the Wills-Weaver mine. The potash operations of Duval became Western Ag-Minerals when sold in the late 1980s. Southwest Potash, now controlled by Horizon Potash, began operation in 1952. Horizon's mine closed in 1994. The shaft of National Potash (now Mississippi Chemical) in Lea County, New Mexico, was completed in 1956, and production started in 1957. The Kerr-McGee facility, completed in 1957, delayed operation until 1965 and is now New Mexico Potash.

Minable potash was discovered in Saskatchewan, Canada, in 1952, but many factors prevented major production until the late 1950s with exports to the United States commencing in 1962. In 1964 U.S. domestic consumption permanently exceeded domestic production. The highest production year for New Mexico potash was 5.2 million mt KCl (3.0 mt  $K_2O$ ) in 1966. Production has decreased steadily as lower-cost Canadian potash has supplied an increasing share of U.S. potash consumption. The cross-over years were 1970 and 1971, when imports first exceeded domestic production. A low of 1.2 million mt of  $K_2O$  was produced in 1986 in the United States.

Overall U.S. potash mine/mill capacity utilization by U.S. producers declined from 83% (1984) to 61% (1985), a trend made more significant because total capacity also declined during this period. Overcapacity is worldwide in 1995 with utilization of about 75%, although it was 85% in New Mexico (Searls, Copeland, and Woodson, 1995).

A dumping finding against Canadian producers by the International Trade Commission in 1987 and the 1988 antidumping agreement between the U.S. Department of Commerce and Canadian producers reversed the downward trend in output and utilization and revitalized the industry in New Mexico. The suspension agreement between the International Trade Administration and the Canadian producers continued through 1994. Civil lawsuits alleging price collusion among potash producers are continuing (Searls, Copeland, and Woodson, 1995). Mississippi Chemical was reactivated in 1988 after several years on standby. Prices increased after a 1988 anti-dumping agreement with Canada allowed AMAX to continue operation until its mine was purchased by Horizon in 1992 (closed in 1994; Table 5). By making lower-grade ores economic, this change in price has increased reserves at other properties in the CPD. Large exports by the former USSR (Belarus) depressed prices and demand in 1992-93, but International Potash Corporation gained more control of Belarus potash output and were able to limit stocks thus helping prices rise slightly in 1994 (Searls, Copeland, and Woodson, 1995). The impact of Canadian, Russian,

and other competition, declining reserves and grades, and increased mining costs, led to many changes in ownership since 1985. Of the older companies, only Mississippi Chemical and IMC remain active (Table 5).

### Economic geology

Potash-bearing evaporites occur in Ochoan (Upper Permian) marine rocks in the Delaware Basin portion of the Permian Basin of west Texas and southeast New Mexico. Ochoan rocks, which are about 240 million years old, overlie Guadalupian carbonates and sandstones within the basin and overlie dominantly reefal carbonates along the basin flanks (many sources including King, 1948; Hayes, 1964; Pray, 1988; and Ulmer-Scholle et al., 1993). The Ochoan is divided into four formations (Fig. 3; Lowenstein, 1988): (1) the Castile Formation (oldest)—halite and banded anhydrite/limestone, (2) the Salado Formation—potash (ore mainly in the McNutt Member), halite, muddy halite, anhydrite, polyhalite, dolomite, and mudstone, (3) the Rustler Formation—halite, gypsum, anhydrite, siliciclastic rocks, dolostone, and limestone, and (4) the Dewey Lake Redbeds (youngest)—siliciclastic mudstone and sandstone. The Castile and basal portions of the Salado have extensive sections of laminated limestone/anhydrite cyclic couplets or "banding" (Madsen and Raup, 1988). Anhydrite interbeds in the Salado show extensive lateral continuity, although often replaced by polyhalite, allowing recognition of 43 marker beds in the CPD (Jones et al., 1960, 1960a).

The Salado Formation, up to a maximum of 670 m thick, is an evaporite sequence dominated by 200-400 m of halite and muddy halite in the KPLA (Lowenstein, 1988). It hosts 12 ore zones; 11 in the middle or McNutt Member (Fig. 4), and a 12th in the upper member. The area underlain by the 12 ore zones is about 4,920 km<sup>2</sup> (Lowenstein, 1988; Jones, 1972).

### McNutt Member

The McNutt Member of the Salado Formation dips about 1° to the southeast within the CPD and is about 120 m thick (Griswold, 1982). The McNutt contains evaporite minerals consisting of sylvite and langbeinite, together with halite, muddy halite, and accessory leonite, kainite, carnallite, polyhalite, kieserite, bloedite, and anhydrite (Barker and Austin, 1993; Table 1). In addition, the McNutt Member consists of non-evaporite minerals such as primary alkali feldspar, hematite, and quartz, and secondary magnesite, illite, clinocllore, talc, talc-saponite, corrensite, and uniform to completely random, interstratified clinochloresaponite (Lowenstein, 1988; Bodine, 1978). All clay minerals appear to be authigenic or recrystallized and have sharp X-ray diffraction maxima.

Mudstone and siliciclastic sediment in the muddy halite of the McNutt Member were derived from erosion of the surrounding basin margin dominantly to the north and east (Lowenstein, 1988). Lowenstein (1988) confirmed previous observations that the present potash salts are secondary and formed later than the primary evaporite cycles and their overall distribution is independent of host lithology.

Potash ore zones are 1-3 m thick and are laterally consistent except where interrupted by salt horses, collapse features (Bachman, 1984), and igneous dikes (Calzia and Hiss, 1978). Commercial deposits were created in some localities by magnesium-undersaturated fluids moving through the zones, but in other areas late fluids destroyed

TABLE 5—Changes in potash property ownership in the Carlsbad potash district since the mid 1980s.

Circa 1985	Circa 1995
AMAX	→ Horizon Potash <sup>1</sup>
Duval	→ Western Ag-Minerals
IMC	→ IMC Global
Kerr McGee	→ New Mexico Potash
Mississippi Chemical	→ Mississippi Chemical
National Potash	→ Mississippi Chemical <sup>2</sup>
PCA	→ Ideal Basic → Lundberg → Eddy Potash

<sup>1</sup>Currently inactive.

<sup>2</sup>Operates compactor and loading facilities on site only.

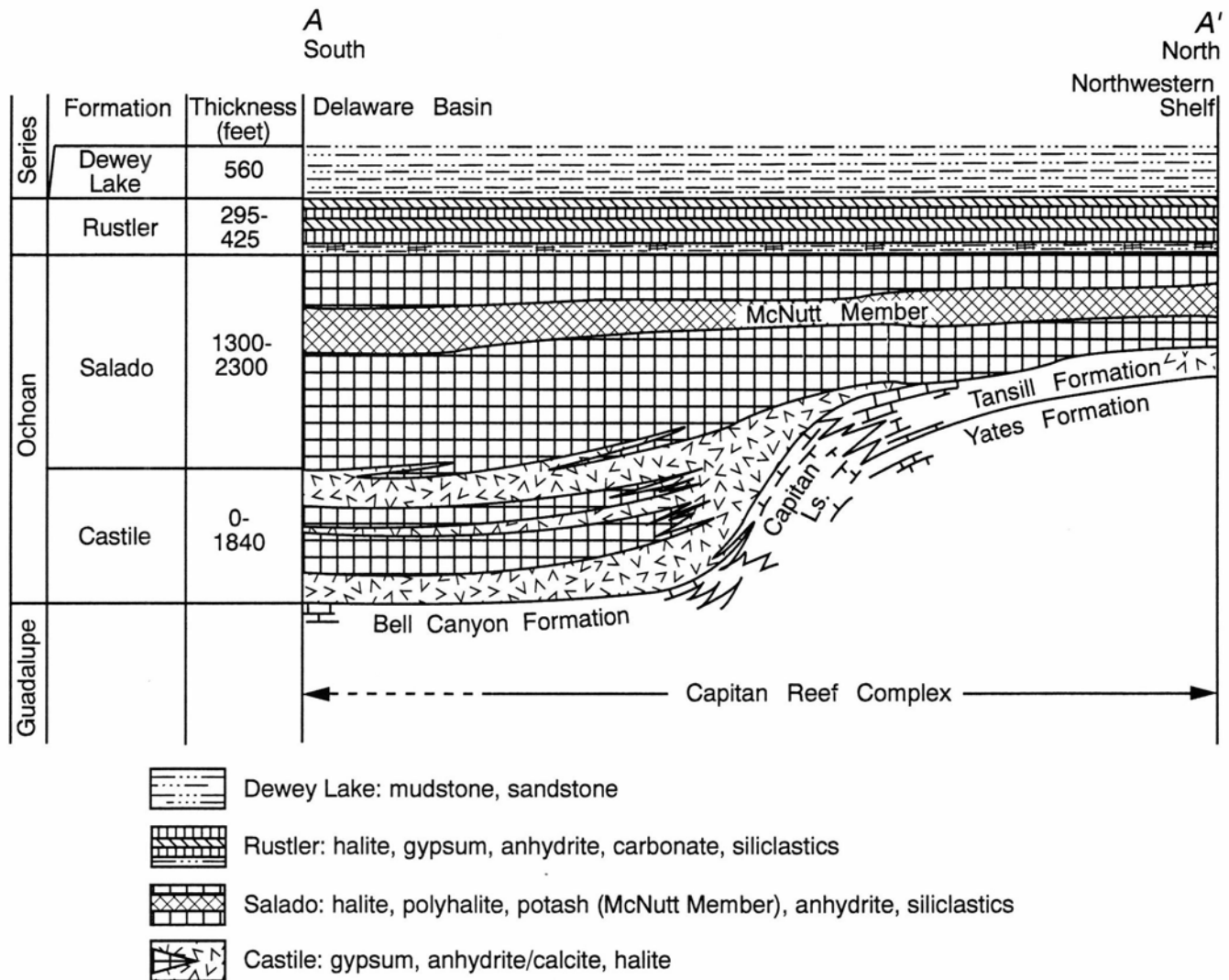

FIGURE 3—Diagrammatic north-south cross section (A-A' on Figure 2) and stratigraphic relationships of the northern edge of the Delaware Basin, southeastern New Mexico (after Jones, 1972; Austin, 1980).

potash ore, producing barren halite (salt horses). The McNutt Member is absent in the subsurface just west of the present mines (Fig. 2).

Ore zone 1 (Fig. 4) accounted for about 80% of past potash production, but it is essentially mined out at currently economic depths. Production is now chiefly from ore zones 3, 4, 5, and 10, which successively overlie zone 1. Mine levels in zone 7 are on standby. Langbeinite is produced from mixed sylvite and langbeinite ores in zones 4 and 5 (Table 6; Harben and Bates, 1990). Near the shallow western boundary of the KPLA, only ore zone 1, stratigraphically lowest, oldest, and richest in potash, was not removed by solution. A typical mixed ore from the Salado in the CPD contains 60% halite and 30% sylvite (usually together as sylvinite), with 5% langbeinite, 2% polyhalite, and 2% insolubles (Cheeseman, 1978).

The average sylvite ore grade in New Mexico decreased from 25 to 30%  $K_2O$  in the 1950s to about 14% today; langbeinite ore now averages 8-10%  $K_2O$ . Potash ore reserves are large within the district and should last for at least 25-35 yrs (Tables 6 and 7) at current extraction rates.

#### Summary of potash-evaporite origin

The majority of potash-bearing bedded-salt deposits originate from evaporation of either seawater or mixtures

of seawater and other brines in restricted marine basins (Schmalz, 1969). The brine depth in an ancient evaporite basin undergoes fluctuations related to sea level, ground-water inflow, precipitation, runoff, and evaporation. Saline minerals can be deposited in deep or shallow water and sometimes during subaerial exposure (Williams-Stroud et al., 1994).

During evaporation of normal seawater, carnallite ( $KCl \cdot MgCl_2 \cdot 6H_2O$ ) rather than sylvite ( $KCl$ ) precipitates due to the high concentration of magnesium in seawater. Mixing of marine brines with other brines or with meteoric water may produce evaporite deposits without carnallite. Potash ore zones often are near the tops of halite beds in relatively thin layers because the potash minerals are precipitated from brines at the higher salinities that occur near the end of the evaporation sequence and later than halite beds. The sodium-to-potash ratio in seawater is about 27:1, so halite is very abundant compared to potash. Nonmarine evaporite deposits occur but have mineralogy very similar to those in marine evaporites (Lowenstein et al., 1989) presenting further complications to origin interpretation.

Carnallite in a salt sequence can be altered to sylvite by the reaction of calcium- or magnesium-poor brine or meteoric water. In many instances this diagenetic pro-

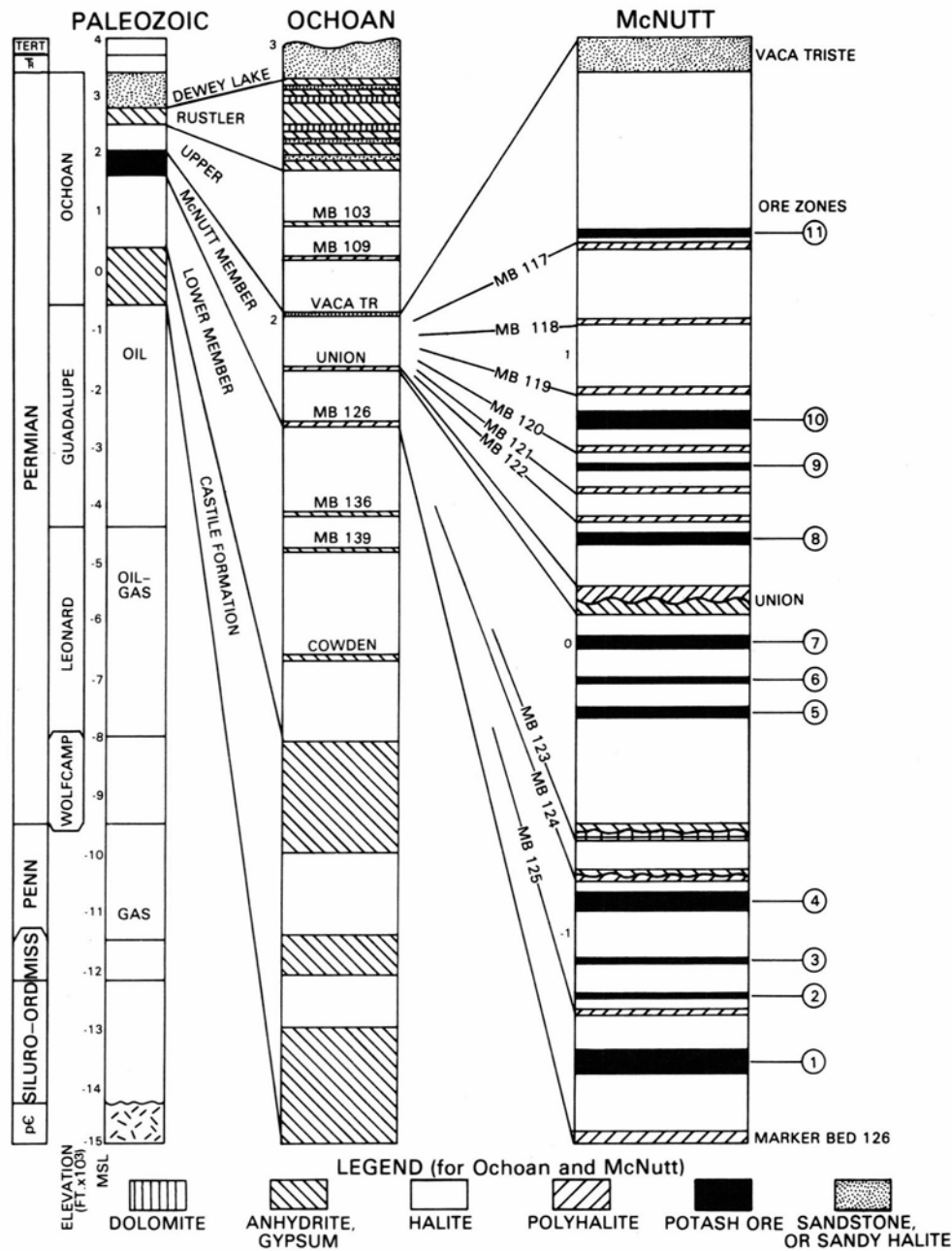

FIGURE 4—Regional stratigraphic column with expanded sections of the Ochoan evaporite and McNutt Member of the Salado Formation (after Griswold, 1982).

cess occurs shortly after deposition of the carnallite layer, as in the case of potash deposits in Thailand (Hite, 1982). The soluble potassium salts of the Salado Formation and the McNutt Member are secondary ones that formed by recycling of either primary carnallite or polyhalite, by migrating Mg- and Ca-poor fluids (Bodine, 1978), or by reactions in place based on changing brine composition, pressure, or temperature. Neither ore minerals, such as sylvite and langbeinite, nor most gangue potash minerals, such as leonite or kainite, are primary in the Salado. Alteration of evaporites is complex and may be syndepositional, postdepositional, or retrograde (Suwanich, 1991). Petrographic and textural relationships and chemical analysis of fluid inclusions of associated halite in potash evaporites suggest that sylvite is primary in some basins (Lowenstein and Spencer, 1990; Wardlaw, 1972). If so, magnesium in

the brines must have been removed, perhaps due to the enrichment of calcium from other brines. Enrichment of seawater with respect to calcium will result in early depletion of sulfate with gypsum/anhydrite precipitation, and will prevent deposition of magnesium sulfates by restricting available sulfate. The magnesium sulfate-poor potash deposits probably precipitated from brines that were high in calcium, and these deposits constitute 60% or more of known potash basins (Hardie, 1991) although the Salado represents magnesium-rich potash deposition.

Most sub-basins of high-grade potash salts are found near the basin center surrounded by successively less soluble salt facies (symmetrical model), but some potash is restricted to the margins of the basin (asymmetrical model). An asymmetrical evaporite distribution, such as that in the Ochoan Delaware Basin, could be formed by

TABLE 6—General mineralogy and minability of ore zones of presently producing companies in the Carlsbad Potash District. After Griswold, 1982; Searls, oral commun., June 1990.

Ore zone	Marker bed near base*	General mineralogy	Producing company	Minability
Eleventh	MB 117	Mostly carnallite, minor sylvite, leonite	—	Not mined to date
Tenth	MB 120	Sylvite, sylvinite	New Mexico Potash, IMC	Second best in the district; high-clay content (6–7%)
Ninth	MB 121	Carnallite, kieserite, sylvite	—	Not mined to date
Eighth	Union	Sylvite	—	Moderate reserves; important in future; high clay
Seventh	—	Sylvite, sylvinite	Mississippi Chemical	Moderate reserves; moderate clay (3–4%)
Sixth	—	Carnallite, kieserite, etc.	—	Not mined to date
Fifth	MB 123	Sylvite, langbeinite	IMC	Moderate reserves; trace clay (1%)
Fourth	—	Langbeinite, sylvite	IMC, Western Ag-Minerals	Principal source of langbeinite; mixed ore
Third	—	Sylvite, sylvinite	Horizon, Eddy Potash	Ranks 3rd in production of sylvite
Second	MB 125	Carnallite, kieserite, etc.	—	Not mined to date
First	MB 126	Sylvite, sylvinite	Eddy Potash	Was the major sylvite-producing zone, now nearly mined out

\*Base of marker bed; see Figure 4.

the reflux model as first described by Ochsenius (1888) and others later (Lowenstein, 1988).

In the reflux model, a shallow bar or sill across the mouth of the basin (proximal end) restricts the flow of seawater, which evaporates into a salt-precipitating brine. The dense brine, with maximum concentration at the distal end, sinks to the bottom, and sets up an undercurrent of higher density brine back toward the proximal (sill) end. The sill, which restricts the inflow of seawater, allows inhibited flow of evaporation-concentrated brines back to the ocean. The least soluble salts are precipitated towards the sill, and the most soluble components precipitate in the deeper parts of the basin. The result is lateral facies changes in a tabular deposit that are due to the asymmetrical salinity gradients in the brine.

The classic reflux model of potash-deposition in the Delaware Basin suggests that the Salado Formation represents repeated cyclic drawdown and brine concentration in a shallow, marginal-marine basin with an intermittent inlet (Hovey Channel) to the southwest (Fig. 1). The Salado Formation and its middle member (McNutt Member) exhibit vertical stacks of two cycles (Type I and II; Fig. 5) on a larger scale (Lowenstein, 1988) than cycles in the Castile (Fig. 3). Some potash salts are not included in the cycles because they are secondary as shown by their displacive and cross-cutting textures and distribution independent of host lithology (Lowenstein, 1988). Relative subsidence was necessary to allow the stacks to develop at least 46 Type I cycles in the Salado (Jones et al., 1960).

The Type I cycle in the Salado is marine dominated (seawater) and consists of an upward sequence, 1-11 m thick, of calcareous / siliciclastic mudstone, anhydrite / polyhalite after gypsum, halite, and muddy halite. These units

record basin shallowing and brine concentration upward during progression from a stratified perennial lake or lagoon to a shallow ephemeral saline lake. The Type I cycle is related to sea level rise relative to the Salado basin and is not as common as Type II cycles (Lowenstein, 1988).

The Type II cycle is continental dominated (meteoric water) with some seawater from seepage or residual brines (brackish water). A Type II cycle is related to a drop in sea level and is volumetrically more important and more numerous than Type I cycles. It is 0.3-6 m thick and consists of halite grading upward into muddy halite. One or more Type II cycles separate Type I cycles

TABLE 7—Active potash mines in New Mexico showing estimated capacity, average ore grade, and mine life at the average 1992 price of \$98.59/mt product. Data from J. P. Searls, U.S. Bureau of Mines, oral comm., 1993.

Operator	County	Product capacity (mt/yr <sup>1</sup> )	Ore grade (% K <sub>2</sub> O)	Mine life (yrs)
Eddy Potash <sup>2</sup>	Eddy	500,000	18	4
Horizon Potash Co. <sup>3</sup>	Eddy	410,000	12	6
IMC Global	Eddy	905,000 <sup>4</sup>	11 <sup>4</sup>	33
Mississippi Chemical	Eddy	270,000	15	125
New Mexico Potash <sup>2</sup>	Eddy	410,000	14	25
Western Ag-Minerals <sup>5</sup>	Eddy	365,000	8 <sup>6</sup>	30

<sup>1</sup>May not be operating at full capacity.

<sup>2</sup>Owned by Trans-Resource, Inc.

<sup>3</sup>Currently inactive and closed.

<sup>4</sup>Muriate, langbeinite, and sulfate combined.

<sup>5</sup>Owned by Rayrock Resources of Canada.

<sup>6</sup>Langbeinite only.



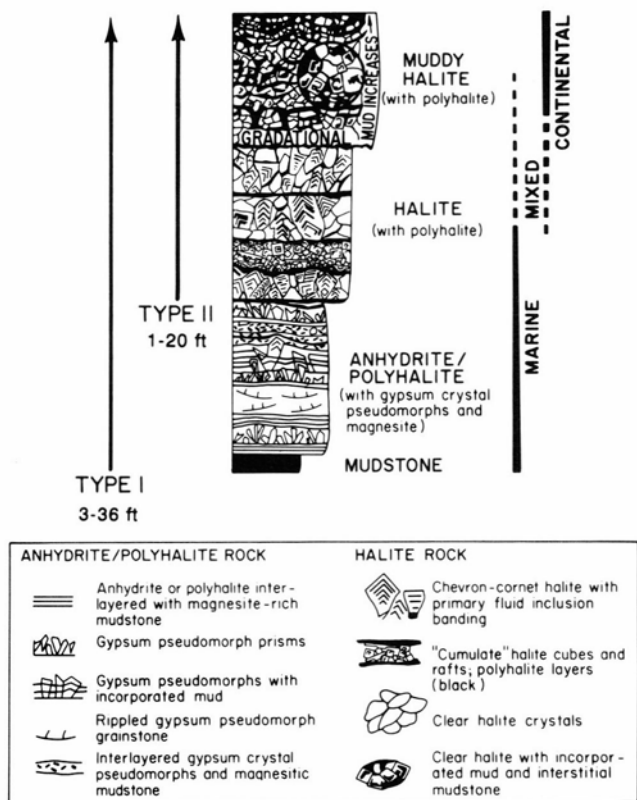

FIGURE 5—Vertical cyclic sequences in the McNutt Member of the Salado Formation, with diagnostic sedimentary structures and textures and interpreted inflow waters (after Lowenstein, 1988).

yielding vertically stacked sedimentary packets representing a maximum time interval of  $10^5$  yrs per cycle. The Type II cycle is similar to the upper portion of a Type I cycle. The Type II shows no evidence of prolonged subaqueous exposure, compared to Type I, and has no anhydrite-gypsum, polyhalite or mudstone layers. The cumulative thickness of Type II exceeds that of Type I in the McNutt (Lowenstein, 1988).

Other hypotheses on the origin of Ochoan rocks near Carlsbad, New Mexico, differ slightly to greatly from the classic reflux model. Leslie et al. (1993) believe the laminated couplets of anhydrite and calcite/organic material, interbedded with massive to poorly laminated halite in the Castile and Salado Formations, were formed below wave base during a period of restricted circulation of marine water. Anderson (1993) suggests that the Castile Formation may be a "nonmarine" evaporite related to considerable meteoric recharge.

### Mining

The high solubility of most potash ores under New Mexico climates limits them to the subsurface—hence all mines in the CPD are underground (Fig. 6). Mine depths range from about 270 to 425 m. These room-and-pillar mines are relatively clean, dry, and orderly because the beds being exploited are relatively shallow, regular, tabular, and nearly flat. Room-and-pillar mining is flexible and allows selective extraction (Sullivan and Michael, 1986) so salt horses are easily bypassed and ore-grade control is good. The location of barren salt horses is unpredictable, but they comprise up to 10% of the ore horizons and are usually avoided. Low concentrations of methane are rarely encountered. Relief holes are drilled



FIGURE 6—View, looking south, of the Eddy Potash (former PCA) mine and mill showing large tailings piles composed mainly of salt with lesser amounts of clay-size particles (slimes) and minor hematite.

in ceilings to dissipate nitrogen (Williams-Stroud et al., 1994). All mines in the CPD consist of at least two shafts for safety and ventilation and older mines have three or more shafts because working faces are now 5-8 km, or more, from main shafts (Searls, 1985).

Continuous mining equipment adapted from coal mining is used to mine most potash ore although blasting is also used. Beds as thin as 1.2 m are mined with mechanical drum miners. Some harder ores, particularly langbeinite, require mechanical undercutters to prepare the working face for drilling and blasting, usually with ANFO (ammonium nitrate and fuel oil). In all cases mechanical loaders, underground crushers, and conveyor belts are used to handle broken ore (Fig. 7). Room-and-pillar methods remove 60-75% of the ore during initial mining. Subsequent removal of most of the support pillars allows extraction to exceed 90% (Sullivan and Michael, 1986; Barker and Austin, 1993). This is not done routinely, particularly when unmined overlying ore zones with minable ore are present, but is usually done only when an area of the mine is being permanently closed.

### Milling

Mills in the CPD produce potash by combinations of separation, flotation, crystallization (Fig. 8), leaching, and heavy-media circuits related to specific ore. Output from

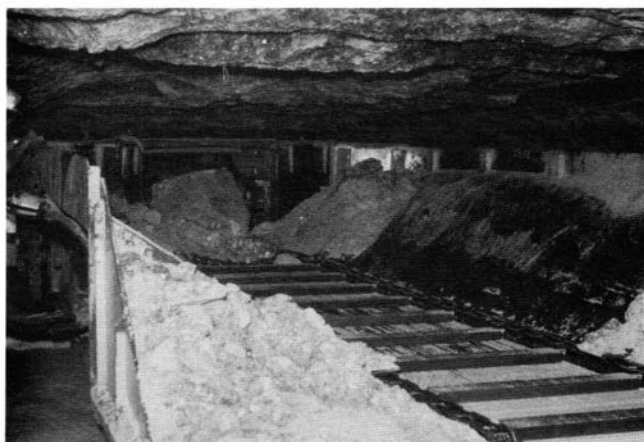

FIGURE 7—Underground primary crusher feeding conveyor belt. View is of feed bin fed by shuttle cars bringing potash from the working face.



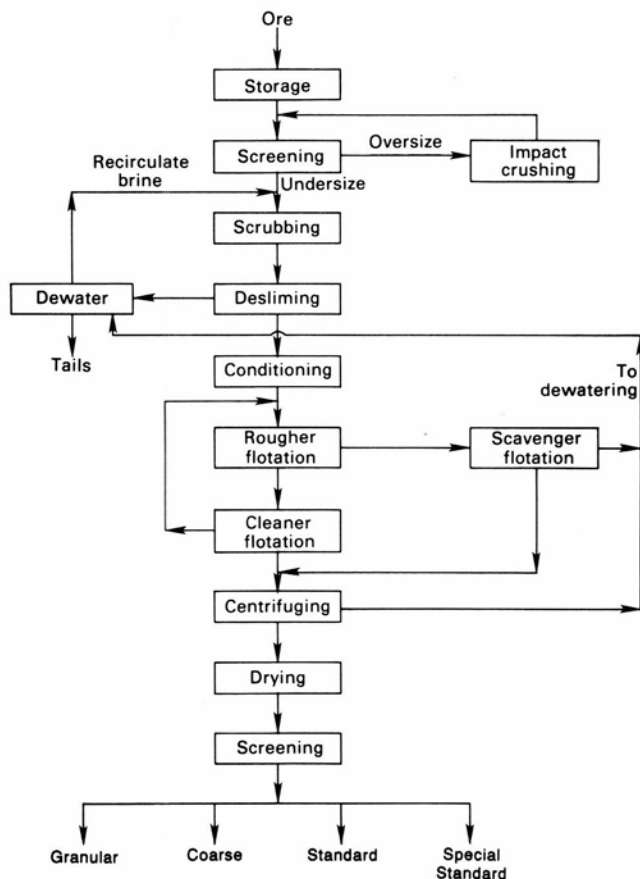

FIGURE 8—Simplified potash flotation circuit (after Sullivan and Michael, 1986).

these circuits is dried in fluid-bed or rotary dryers and sized over screens to yield final products. Potash ore is ground to break up sylvite-halite agglomerates (Searls, 1985) followed by froth flotation (Fig. 8). Frothers such as cresylic acid, pine oil, or alcohol are added to the slurry. Sylvite is floated from halite in an aqueous solution saturated with both sodium and potassium chlorides at pulp densities of 20-35% solids and recovery generally exceeds 80%. Collectors typically are hydrochloride and acetate salts of aliphatic amines with chain lengths of 12-24 carbon atoms. IMC uses heavy media separation on sylvite/langbeinite ore prior to flotation and produces potassium sulfate by reacting potassium chloride with various sulfate materials including langbeinite. Western Ag-Minerals washes langbeinite ore to leach more soluble gangue without a flotation stage. Fine-grained MOP from flotation must be coarsened by compaction between rollers, crushed, and sized to bulk-blended fertilizer specifications. Potash is generally stored indoors (Fig. 9) in large amounts to meet seasonal surges in demand.

The abundance and mineralogy of clay minerals are significant in processing potash ores, in particular, the clay-rich 10th ore zone. Clay-size particles (slimes), composed dominantly of clay minerals, make up from a trace to about 10% of ore zones in the CPD. Clay minerals absorb the reagents added early before the crystallization stage, thus raising reagent cost, and hinder recovery (Gundiler, 1995) among several deleterious effects. Each mill is designed for a specific slimes content in its feed stock (Fig. 10). Thus some ore zones cannot be processed efficiently in specific plants. For example, the Mississippi Chemical mill can handle up to 4.5% slimes. Beneficiation by dissolution and

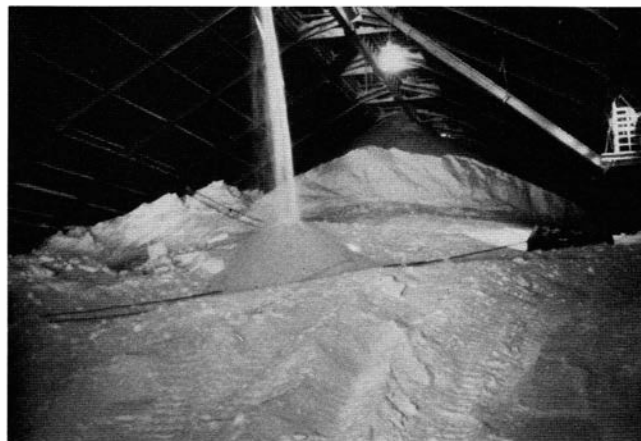

FIGURE 9—Potash product being discharged into covered storage. Potash is reclaimed from underneath.

vacuum recrystallization is used on clay-rich or fine-grained ores. This method is used by New Mexico Potash (Fig. 11) whose ores contain about 7% clay (Searls, 1985).

Clay minerals preferentially interact with the amines used to coat sylvite in sylvinitic ores and frothers used in flotation cells (Searls, 1985). This is a result of the large surface areas of clays, their residual charges, adsorption, absorption, and colloid formation. Expandable trioctahedral clay minerals such as corrensite, saponite, and clinocllore-saponite have more surface area than other clay minerals and can form colloids with the brines of either the flotation or crystallization circuits. These characteristics of clay minerals interfere with beneficiation and increase chemical use.

Potash tailings in the CPD, largely halite and clay, are stored or disposed of on the surface (Fig. 12). Solid wastes are piled and monitored for salt leakage, which is minimal owing to the semi-arid climate. Brines are evaporated in impoundments or in a natural saline lake. Methods for returning tailings to the mine are being studied but are more likely to be initiated in potash districts less price sensitive than the CPD.

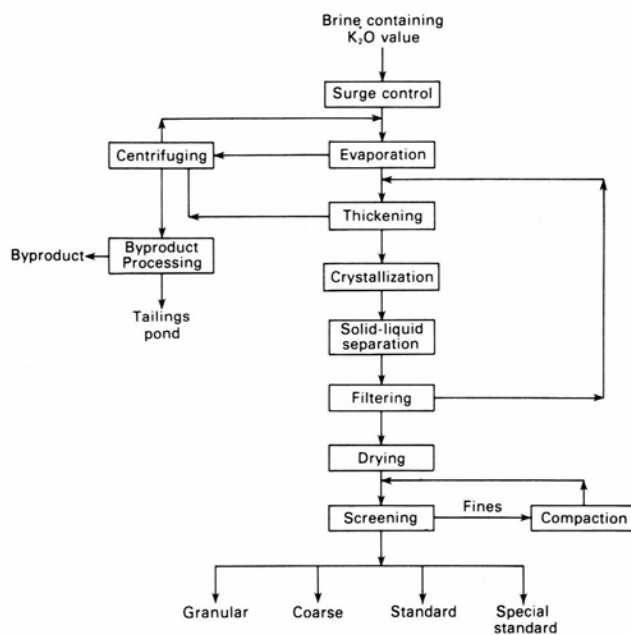

FIGURE 10—Simplified potash crystallization circuit (after Sullivan and Michael, 1986).

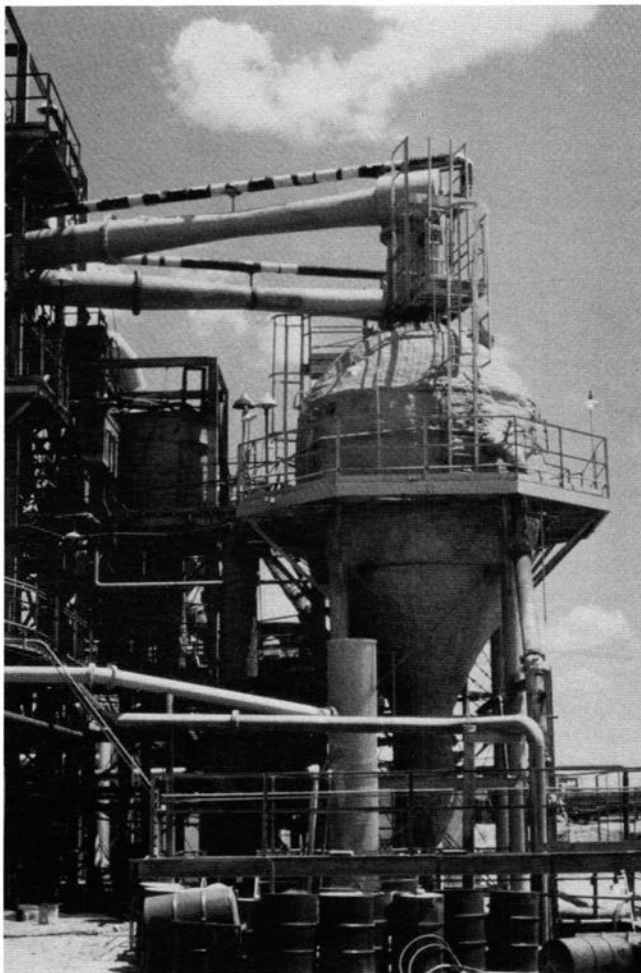

FIGURE 11—Vacuum crystallization tower at the New Mexico Potash mill.

#### Summary of economic factors

Activity by other industries can affect the production of potash from southeastern New Mexico; notable are agriculture, petroleum, and nuclear waste disposal. The main use of potash as a fertilizer ties it to cyclic trends in the agricultural industry. These trends are related to complex interactions between weather and climate, advances in crop genetics, soil science, farming practices, GNP of importing nations, farm income, population growth, efficient distribution systems, freight rates and backhauls, substitutes (Williams-Stroud et al., 1994), taxes, and tariffs. Decisions to drill for petroleum below potash beds, presumably rendering the potash unminable, are decided by the Bureau of Land Management (BLM), who manages the federal and state land within the Potash Enclave in consultation with representatives of the potash and petroleum industries (SearIs, 1992). The BLM historically has decided in favor of preserving potash reserves rather than petroleum production unless the petroleum well can be drilled through unminable areas inside the KPLA or from outside the KPLA. Also impacting the potash industry is the Waste Isolation Pilot Plant (WIPP) along the southeast boundary of the KPLA (Fig. 2).

#### References

Adams, S. S., and Hite, R. J., 1983, Potash; *in* Lefond, S. J. (ed.), *Industrial minerals and rocks*, 5th ed.: Society of Mining Engineers of the American Institute of Mining, Metallurgical, and Petroleum Engineers Inc., New York, pp. 1049-1077.

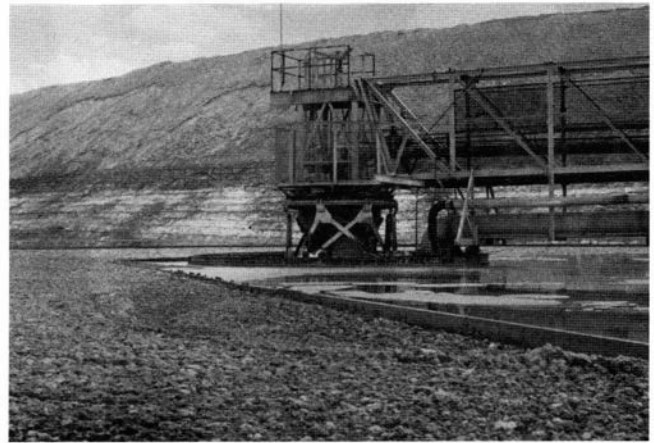

FIGURE 12—Desliming tank at Eddy Potash (former PCA) with tailings pile (mainly salt water slimes and hematite) in background (see Figure 6).

- Anderson, R. Y., 1993, The Castile as a "nonmarine" evaporite; *in* Love, D. W., Hawley, J. W., Kues, B. S., Austin, G. S., and Barker, J. M. (eds.), *Carlsbad region, New Mexico and west Texas*: New Mexico Geological Society, Guidebook 44, pp. 12-13.
- Austin, G. S., 1980, Potash in New Mexico: *New Mexico Geology*, v. 2, no 1, pp. 7-9.
- Bachman, G. O., 1984, Regional geology of Ochoan evaporites, northern part of the Delaware Basin: *New Mexico Bureau of Mines and Mineral Resources, Circular 184*, 22 pp.
- Barker, J. M. and Austin, G. S., 1993, Economic geology of the Carlsbad Potash District, New Mexico; *in* Love, D. W., Hawley, J. W., Kues, B. S., Austin, G. S., and Barker, J. M. (eds.), *Carlsbad region, New Mexico and west Texas*: New Mexico Geological Society, Guidebook 44, pp. 283-291.
- Bodine, M. W., Jr., 1978, Clay mineral assemblages from drill core of Ochoan evaporites, Eddy County, New Mexico; *in* Austin, G. S. (compiler), *Geology and mineral deposits of Ochoan rocks in Delaware Basin and adjacent areas*: New Mexico Bureau of Mines and Mineral Resources, Circular 159, pp. 21-31.
- Calzia, J. P. and Hiss, W. L., 1978, Igneous rocks in northern Delaware Basin, New Mexico and Texas; *in* Austin, G. S. (compiler), *Geology and mineral deposits of Ochoan rocks in Delaware Basin and adjacent areas*: New Mexico Bureau of Mines and Mineral Resources, Circular 159, pp. 39-45.
- Cheeseman, R. J., 1978, Geology and oil/potash resources of Delaware Basin, Eddy, and Lea Counties, New Mexico; *in* Austin, G. S. (compiler), *Geology and mineral deposits of Ochoan rocks in Delaware Basin and adjacent areas*: New Mexico Bureau of Mines and Mineral Resources, Circular 159, pp. 7-14.
- Griswold, G. B., 1982, Geology overview of the Carlsbad Potash Mining District; *in* Austin, G. S. (compiler), *Industrial rocks and mineral of the Southwest*: New Mexico Bureau of Mines and Mineral Resources, Circular 182, pp. 17-21.
- Gundiler, I., 1995, Potash processing technology; *in* New Mexico Bureau of Mines and Mineral Resources, 1995, *Evaluation of mineral resources at the Waste Isolation Pilot Plant (WIPP) site—Final report*: [Unpublished report], Contract No PO75-WJJ6441452, Westinghouse Electric Corp., Waste Isolation Division, v. 2, p. 1-4.
- Harben, P. W., and Bates, R. L., 1990, *Industrial minerals: Geology and world deposits*: Industrial Minerals Division, Metal Bulletin Plc., London, 312 pp.
- Hardie, L. A., 1991, On the significance of evaporites: *Annual Reviews of Earth and Planetary Sciences*, v. 19, pp. 131-168.
- Hayes P. T., 1964, *Geology of the Guadalupe Mountains, New Mexico*: U.S. Geological Survey, Professional Paper 446, 69 pp.
- Hite, R. J., 1982, Progress report on the potash deposits of the Khorat Plateau, Thailand: U.S. Geological Survey, Open-file Report 82-1096, pp. 48-66.

- Jones, C. L., 1972, Permian Basin potash deposits, southwestern United States; *Geology of saline deposits: UNESCO, Earth Science Series 7, Proceedings, Hanover Symposium, 1968*, pp. 191-201 (reprinted in Brokaw, A.L., Jones, C.L., and Hayes, M.E., 1972, *Geology and hydrology of the Carlsbad potash area, Eddy and Lea Counties, New Mexico: U.S. Geological Survey, Open-file Report 4339-1, Appendix A*).
- Jones, C. L., Bowles, C. G., and Bell, K. G., 1960, Experimental drill-hole logging in potash deposits of the Carlsbad District, New Mexico: U.S. Geological Survey, Open-file Report, 22 pp.
- Jones, C. L., Bowles, C. G., and Disbrow, A. E., 1960a, Generalized columnar section and radioactivity log, Carlsbad District: U.S. Geological Survey, Open-file Report, 25 pp.
- King, P. B., 1948, *Geology of the southern Guadalupe Mountains, Texas: U.S. Geological Survey, Professional Paper 215*, 183 pp.
- Leslie, A., Kendall, A., and Harwood, G., 1993, The Castile Formation: A continuing paradox; in Love, D. W., Hawley, J. W., Kues, B. S., Austin, G. S., and Barker, J. M. (eds.), *Carlsbad Region, New Mexico and west Texas: New Mexico Geological Society, Guidebook 44*, pp. 13-14.
- Lowenstein, T. K., 1988, Origin of depositional cycles in the Permian "saline giant": The Salado (McNutt Zone) evaporites of New Mexico and Texas: *Geological Society America Bulletin*, v. 100, pp. 592-608.
- Lowenstein, T. K., Spencer R. J., and Pengxi, Z., 1989, Origin of ancient potash evaporites: Clues from the modern nonmarine Qaidam Basin of western China: *Science*, v. 245, pp. 1090-1092.
- Lowenstein, T. K., and Spencer, R. J., 1990, Syndepositional origin of potash evaporites: Petrographic and fluid inclusion evidence: *American Journal of Science*, v. 290, pp. 1-42.
- Madsen, B. M., and Raup, O. B., 1988, Characteristics of the boundary between the Castile and Salado Formations near the western edge of the Delaware Basin, southeastern New Mexico: *New Mexico Geology*, v. 10, pp. 1-5,9.
- New Mexico Bureau of Mines and Mineral Resources, 1995, Evaluation of mineral resources at the Waste Isolation Pilot Plant (WIPP) site-Final report: [Unpublished report], Contract No. PO-75-WJJ6441452, Westinghouse Electric Corp., Waste Isolation Division, 4 vol.
- O'Driscoll, M., 1990, Minerals in the US southwest-Breaking rocks in the hot sun: *Industrial Minerals*, no. 270, pp. 52-87.
- Ochsenius, K., 1888, On the formation of rock salt beds and mother liquor salts: *Proceedings, Philadelphia Academic Society, Part 2*, pp. 181-187.
- Pray, L. C., 1988, *Geology of the Western Escarpment, Guadalupe Mountains, Texas; in Sarg, J. F., Rossen, C., Lehmann, P. J., and Pary, L. C. (eds.), Geologic guide to the Western Escarpment, Guadalupe Mountains, Texas: SEPM Permian Basin Section, Publication 88-30*, pp. 1-8.
- Searls, J. P., 1985, Potash; in *Mineral facts and problems: U.S. Bureau of Mines, Bulletin 675*, pp. 617-633.
- Searls, J. P., 1992, Potash 1991: U.S. Bureau of Mines, Annual Report, 16 pp.
- Searls, J. P., 1993, Potash; in *Mineral Commodity Summaries, 1993: U.S. Bureau of Mines*, pp. 132-133.
- Searls, J. P., Copeland, S., and Woodson, V., 1995, Potash, Annual Review-1994: U.S. Bureau of Mines, 12 p.
- Schmalz, R. F., 1969, Deep water evaporite deposition: A genetic model: *American Association of Petroleum Geologist Bulletin*, v. 53, pp. 798-823.
- Sullivan, D. E. and Michael, N., 1986, Potash availability-Market economy countries-A minerals availability appraisal: U.S. Bureau of Mines, Information Circular 9084, 32 pp.
- Suwanich, P., 1991, Relationships between soluble and insoluble minerals in the McNutt Member, Salado Formation, Delaware Basin, New Mexico: Unpublished MS independent study, New Mexico Institute of Mining and Technology, Socorro, New Mexico, 98 pp.
- Ulmer-Scholle, D. S., Scholle, P. A., and Brady, P. V., 1993, Silicification of evaporites in back-reef carbonates: *Journal of Sedimentary Petrology*, v. 63, pp. 955-965.
- Walls, J. M., 1985, Overall view of Carlsbad potash: [Unpublished manuscript], New Mexico Bureau of Mines and Mineral Resources, 9 pp.
- Wardlaw, N. C., 1972, Unusual marine evaporites with salts of calcium and magnesium chloride in Cretaceous basins of Sergipe, Brazil: *Economic Geology*, v. 67, pp. 156-168.
- Williams-Stroud, S. C., Searls, J. P., and Hite, R. J., 1994, Potash Resources; in Carr, D. D. (ed.), *Industrial mineral and rocks, 6th ed.: Society for Mining, Metallurgy, and Exploration Inc., Littleton, Colorado*, pp. 783-802.

# Modern New Mexico adobe—A response to some environmental concerns

George S. Austin<sup>1</sup> and Matthew R. Goolsby<sup>2</sup>

<sup>1</sup>*New Mexico Bureau of Mines & Mineral Resources, New Mexico Tech, 801 Leroy Place, Socorro, New Mexico 87801-4796, USA*  
<sup>2</sup>*Department of Earth and Environmental Science, New Mexico Tech, 801 Leroy Place, Socorro, New Mexico 87801-4796, USA*

**Abstract**—Although among the oldest building techniques mastered by early man, the use of mud as a building material parallels the birth and spread of great ancient civilizations. Even today, earth remains the primary building material for over 50% of the world's population. In the American Southwest modern adobe structures are relatively common, particularly in northern New Mexico. With the aid of up-to-date fixtures, adobe homes rank high on the scale of livability, with a number of advantages over homes constructed of other materials. In addition, the basic raw material for adobe is abundant. In this day when the consumption of resources is frequently called to question, buildings composed mostly of dried mud are "environmentally friendly."

New Mexico's 20,000 adobe dwellings represent about one-third of the adobe buildings now in use in the United States. Although today less than 3% of the new homes in the state are constructed with adobe each year, the annual number averages between 500 and 600 new dwellings. Commercially constructed adobe houses usually contain above-average square footage and the cost can far exceed that of comparable homes constructed with other materials. However, in some areas, particularly in rural northern New Mexico, many backyard-adobe producers build their own homes on evenings or weekends while working full time, and in many cases these homes are completed without extensive debt.

Today, most builders purchase the adobe bricks from commercial yards found throughout New Mexico, but those are concentrated in the northern half of the state. The adobe operation is a labor-intensive but fuel-efficient seasonal industry with block production usually limited by the number of frost-free days. The principal standard-size adobe brick produced and used in New Mexico measures 4 x 10 x 14 inches and weighs about 30 lbs. In addition to traditional adobe bricks made with wooden or metal molds, hydraulically pressed mud-block machines are manufactured in New Mexico and are used here sporadically. The third adobe-production technique is rammed-earth walls or pise, in which layers of moist mud are placed between forms and tamped.

All types of adobe structures are common in New Mexico. Not only as older structures built when adobe was the chief building material, but now when adobe is considered a superior, culturally important, and environmentally preferred construction material. The techniques used in earth construction will remain not only acceptable but popular for years to come.

## El adobe moderno de Nuevo Mexico— replica a inquietudes ambientales

**Resumen**—El uso del adobe es una de las técnicas de construcción más antiguas. El uso del barro como material de construcción acompañó el nacimiento y proliferación de grandes civilizaciones antiguas. Tierra sigue siendo el principal material de construcción para más del 50% de la población mundial. En el suroeste de Norte América, estructuras modernas de adobe son relativamente comunes, especialmente en el norte de Nuevo Mexico. Gracias a recursos modernos las casas de adobe son muy cómodas y tienen ventajas sobre viviendas construidas de otros materiales. La materia prima existe en abundancia. Hoy en día, cuando muchas veces se cuestiona el consumo de recursos naturales, edificios hechos, en su mayor parte, de barro desecado, son considerados "benévolos al ambiente."

Las 20,000 viviendas de adobe que existen en Nuevo Mexico representan, más o menos, una tercera parte de los edificios de adobe que hoy se usan en los E.U.A. Aunque en Nuevo Mexico menos del 3% de nuevas viviendas se construyen con adobe, esto representa un promedio de entre 500 a 600 anualmente. Generalmente casas de adobe construidas por empresas comerciales son de superficie mayor que el promedio de casas nuevas construidas de otros materiales y pueden costar mucho más que estas últimas. En algunos lugares, especialmente en zonas rurales del norte de Nuevo Mexico, es común que los pobladores hacen sus propios adobes en el patio y construyen ellos mismos sus casas en las tardes después de venir del trabajo y durante los fines de semana. En muchos casos, estas viviendas se terminan sin que los dueños tengan que contraer mayores deudas.

Actualmente, la mayoría de los constructores compran sus bloques de adobe en centros comerciales que existen en todas partes de Nuevo Mexico, pero más numerosos en el norte del estado. La fabricación de bloques de adobe requiere mucha mano de obra pero es económica en cuanto al consumo de energía; es una industria de temporada, limitada generalmente a los días

sin escarcha. El tamaño *standard* del bloque de adobe que mas se usa en Nuevo Mexico es de 4 x 10 x 14 pulgadas y pesa unas 30 libras. Además de los bloques tradicionales que se hacen en moldes de madera o de metal, en Nuevo Mexico se construyen prensas hidráulicas para fabricar adobes pero solo se las usa esporádicamente en el estado. Un tercer método de producción de adobe es la pared de barro pisado, o *piste*: se colocan capas de barro húmedo entre moldes que luego se apisonan.

En Nuevo Mexico son comunes todos los tipos de estructuras de adobe, no solamente en estructuras más antiguas, construidas cuando el adobe era el material de construcción principal, sino también ahora cuando se considera al adobe un material de construcción superior, culturalmente importante y ambientalmente preferible. Las técnicas usadas en construcciones de tierra no solo continuarán siendo aceptables, sino serán populares en años venideros.

### Introduction

Mud is one of the oldest building materials used by man, but it is not only of historic interest. Even today in many parts of the world, particularly in lightly forested areas, it is the chief building material. Many authorities believe that at least 30%, and perhaps as much as 50%, of the world's population currently lives in earthen dwellings (Dethier, 1985; Coffman et al., 1990). Not all of these people are members of primitive societies or live in "third world" countries. European, African, Asian, and North and South American countries contain a large number of such structures. Today, the word "adobe" is used to describe various earth building materials and techniques, usually referring to sun-dried adobe brick now used in the United States, but "adobe" is also applied to puddled adobe structures, mud-plastered logs or branches (Jacal or wattle-and-daub), pressed-earth blocks, and rammed-earth walls or pisé (Ferm, 1985; Smith and Austin, 1989).

The American Southwest has long had a love affair with adobe, and the landscapes of New Mexico, Arizona, Texas, and California contain many examples of enduring adobe homes. Old military forts, churches, and commercial buildings also attest to its popularity. New Mexico, both historically and today, is the largest domestic producer and user of adobes. During the 1980s, 3 to 4 million adobe bricks and pressed-earth blocks were produced in New Mexico each year by about 50 commercial manufacturers (Smith and Austin, 1989). In 1994 about 3 million adobes were made commercially, as the industry became more concentrated in the hands of a few large producers (Table 1; Fig. 1).

About 60,000 adobe buildings, representing one-third of the adobe dwellings in the United States, are in use in New Mexico (Gerbrandt and May, 1986). Although today only 2-3% of new homes built each year in New Mexico are constructed with adobe, the number usually

TABLE 1—Earth-materials production companies active in New Mexico in 1994.

ADOBES				
Map no. (Fig. 1)	Name and mailing address	Telephone	County	1994 production
1	Adobe Bricks of New Mexico Box 733 Santa Cruz, NM 87467 Dennis Duran, Owner	505-753-6189	Santa Fe	100,000
2	Adobe Factory P.O. Box 519 Alcade, NM 87511 Mel Medina, Owner	505-852-4131	Rio Arriba	950,000
3	Big "M" Sand and Cinder Box 33 Bernalillo, NM 87004 Randy Montoya, Owner	505-867-5498	Sandoval	50,000
4	DeLaO Adobe Brick P.O. Box 1283 Anthony, NM 88021 Antonio DeLaO, Owner	505-882-5278	Doña Ana	60,000
5	Eloy Montano Sand & Gravel 14 Calle Chuparosa Santa Fe, NM 87505 Eloy Montano, Owner	505-471-4747	Santa Fe	35,000
6	Gilbert Montano 503 Barela Lane Santa Fe, NM 87501 Gilbert Montano, Owner	505-983-2838	Santa Fe	95,000
7	New Mexico Earth P.O. Box 10506 Alameda, NM 87184 Richard Levine, Owner	505-898-1271	Bernalillo	600,000

TABLE 1—continued.

<b>ADOBES</b>				
Map no. (Fig. 1)	<u>Name and mailing address</u>	<u>Telephone</u>	<u>County</u>	<u>1994 production</u>
8	Leroy Otero 2725 Highway 47 Los Lunas, NM 87031 Leroy Otero, Owner	505-864-4054	Valencia	40,000
9	Philip Otero 2055 Winchester Bosque Farms, NM 87068 Philip Otero, Owner	505-869-0934	Valencia	50,000
10	Simon Otero 224 El Cerro Loop Los Lunas, NM 87031 Simon Otero, Owner	505-865-7133	Valencia	15,000
11	Sol Systems Adobe Box 104 Corrales, NM 87048 Manuel Ruiz, Owner	505-898-2218	Sandoval	300,000
12	Rio Abajo Adobe 105 W. Aragon Belen, NM 87002 Jerry Sanchez, Owner	505-864-6191	Valencia	250,000
13	Trini Velarde Box 726 Rancho de Taos, NM 87557 Trini Velarde, Owner	505-758-4185	Taos	16,000
14	Western Adobe 7800 Tower Road SW Albuquerque, NM 87121 Dean Leach, Owner	505-836-1839	Bernalillo	200,000
			<b>TOTAL</b>	2,761,000
Map no. (Fig. 1)	<u>Name and mailing address</u>	<u>Telephone</u>	<u>County</u>	<u>1994 production</u>
<u>No production in 1994</u>				
15	Aguires Services P.O. Box 475 Rancho de Taos, NM 87557 Ismael Aguires, Owner	505-758-9181	Taos	0
16	Adobes by Sun and Soil Inc. Box 99 Edgewood, NM 87015 Don Huston, Owner	505-281-9006	Santa Fe	0
17	Ralph Mondragon Box 199 Rancho de Taos, NM 87557 Ralph Mondragon, Owner	505-758-3644	Taos	0
18	Rodriguez Brothers Rt. 6, Box 22 Santa Fe, NM 87501 George and Jim Rodriguez, Owners	505-471-3375	Santa Fe	0
19	Tim's Adobes Box 1534 Bernalillo, NM 87004 Tim Montoya, Owner	505-867-4847	Sandoval	0
<b>PRESSED-EARTH BLOCKS</b>				
Map letter (Fig. 1)	<u>Name and mailing address</u>	<u>Telephone</u>	<u>County</u>	<u>1994 production</u>
A	Adobe International Box 1284 Grants, NM 87020 Henry Elkins, Owner	505-287-3961	Cibola	108,000 (made about 50 machines)
B	Alternative Block, Inc. P.O. Box 7397 Grants, NM 87020	(Closed operations in New Mexico, January 1995)		

TABLE 1—continued.

<b>ADOBES</b>				
Map no. (Fig. 1)	<u>Name and mailing address</u>	<u>Telephone</u>	<u>County</u>	<u>1994 production</u>
C	Habitat for Humanity P.O. Box 2844 Santa Fe, NM 87501 Cisco Davis, Executive Director	505-986-5580	Santa Fe	10,000
D	Southwest Alternatives, Ltd. P.O. Box 1365 Corrales, NM 87048 David Lineau, Owner	505-898-6609	Sandoval	(made 6 machines)
			<b>TOTAL</b>	<u>118,000</u>
<u>No production in 1994</u>				
E	Coyote Adobe, Inc. 247-F Rosario Boulevard Santa Fe, NM 87501 Robert W. Higginson and Paul Romero, Owners	505-983-5376	Santa Fe	0
F	Tide Corporation 8325 Washington St. NE Albuquerque, NM 87113	505-343-8955	Bernalillo	0
<b>RAMMED-EARTH BUILDERS</b>				
Map symbol (Fig. 1)	<u>Name and mailing address</u>	<u>Telephone</u>	<u>County</u>	<u>1994 production</u>
⊗	Huston Construction Box 99 Edgewood, NM 87015 Stan Huston, Owner	505-281-9534	Santa Fe	7 houses
⊕	Soledad Canyon Earth Builders P.O. Box 274 Mesilla, NM 88046 Mario Bellestri, Owner	505-521-9350	Doña Ana	4 houses
			<b>TOTAL</b>	<u>11 houses</u>

averages between 500 and 600 new dwellings. Based on examination of building permits in New Mexico and discussions with local architects, realtors, and planners throughout the Southwest, it appears that most new adobe dwellings are built for high-income customers. The houses usually have above-average square footage, with the addition of extensive southwestern architectural details and style. However, in some areas, particularly in parts of rural northern New Mexico, many backyard adobe producers build their own homes (McHenry, 1985). This is often done on a part-time basis, while the builder works full time for a local business or government agency. Often the house is a family project and is completed without an extensive debt or long-term mortgage payments.

#### Raw materials

Adobe soil used by present-day adobe producers, and probably past adobe producers as well, is principally sandy loam (50% clay and silt), although clayey silts are used in some areas (Coffman et al., 1990). In New Mexico the best adobe soils are those developed on fine-grained stream deposits, particularly Holocene terrace deposits and older, loosely compacted geologic formations. The Santa Fe Group of Tertiary age located in the Rio Grande valley is a good example. Some modern adobe producers use a mixture of materials from the screened fines of aggregate operations and mud from irrigation ditches in the river valleys, combined with varying amounts of sand, to produce the proper blend (Austin, 1994).

#### Mineralogy

Bulk mineralogy—X-ray diffraction analyses of whole-rock samples from many parts of the world where adobe is the dominant construction material show the major constituents of adobe to be quartz and feldspar, with lesser amounts (in order of abundance) of calcite, clay minerals, and gypsum (Coffman et al., 1990). Adobes from arid climates contain considerable calcite; in some cases calcite is second only to quartz in volume. Quartz, feldspar, most of the clay minerals, and some calcite commonly are derived from the mechanical/chemical breakdown of older rocks units. Some of the clay minerals, much of the calcite, and perhaps all of the gypsum are precipitated from evaporating water.

Clay mineralogy—Clay-size particles consist dominantly of clay minerals, but nearly all clay-size fractions contain minor amounts of quartz and calcite, and occasionally other nonclay minerals. In New Mexico, clay-size particles in commercial adobe soils are the most compositionally variable. However, the clay-mineral groups in this size fraction consist of about equal parts of expandable clay minerals (smectite and mixed-layer illite/smectite or I/S) and non-expandable clay minerals (kaolinite, illite, and chlorite), with minor quartz, calcite, and feldspar (Smith and Austin, 1989; Austin, 1994). In the arid American Southwest smectite is commonly calcium-rich and the I/S is randomly interstratified. A study of 42 New Mexican commercial adobe soils by Smith and Austin (1989) revealed that only two contained chlorite, and

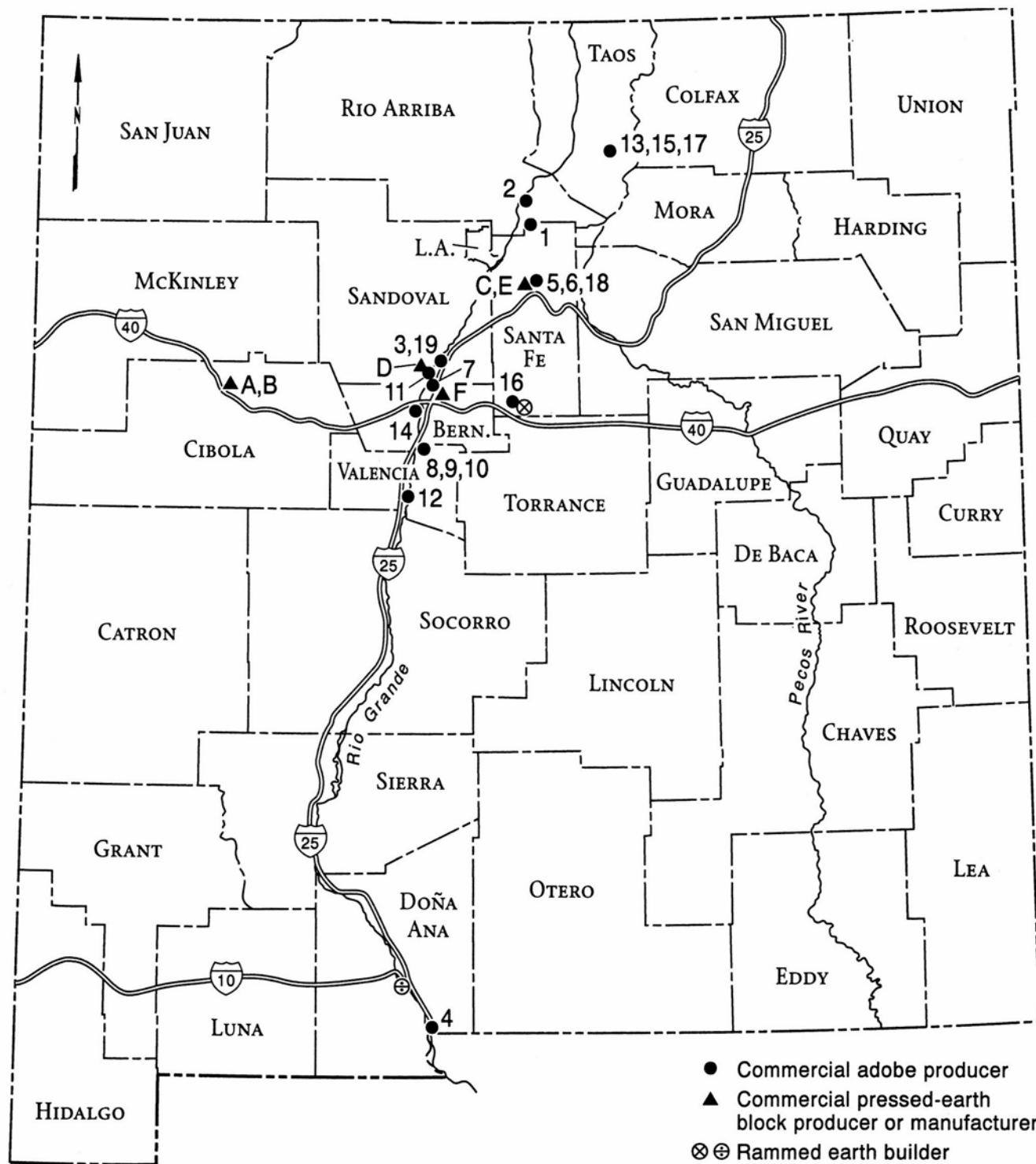

FIGURE 1—Locations of commercial adobe-brick producers, pressed-earth-block machine manufacturers, and rammed-earth-construction companies active in New Mexico in 1994.

that vermiculite, sepiolite, and palygorskite were absent.

Soils in temperate climates, as in the midwest and northeast United States, contain an abundance of illite (Potter et al., 1975). The clay minerals in earthen structures of that region and in Europe commonly contain illite with lesser amounts of kaolinite, smectite, I/S, chlorite, and vermiculite. In contrast, the clay-size fractions of soils in humid tropical areas are typically acid, with kaolinite as the dominant clay mineral and lesser amounts of I/S, illite, smectite, and others (Chamley, 1989). Mud or adobe structures are known in these areas, but for wood

and stone in older structures and concrete and metal in newer ones are dominant.

#### Chemical properties

Soils in the arid New Mexican climate are typically alkaline. Ground water near the Rio Grande valley is generally hard to extremely hard, containing total dissolved solids (TDS) ranging from about a hundred to several thousand parts per million (Wilkins, 1986; Anderholm, 1987). Soluble salts, notably calcium carbonate and calcium sulfate, precipitate as this water evaporates. White



crusts of these salts at the surface are common in marshy areas of the state during drier times of the year. The stability of the desert surfaces causes precipitation of calcium carbonate from ground water, initially producing calcium-rich soils, followed by impermeable pedogenic calcite layers called caliche a few centimeters to a few meters below the surface (Hawley, 1994).

Adobe walls are remarkably durable in the American Southwest climate and with proper care last hundreds of years. Great care is taken to keep the wall interior dry. Walls in some Indian pueblos are re-covered with a "natural mud plaster" on a yearly basis as part of "community service." The natural plaster has about the same mineral and chemical composition as the walls themselves but is slightly finer-grained. The plaster is expected to wash off slowly during the year and to be replaced during the next replastering. The slow removal of the plaster apparently is due to precipitation of calcite and gypsum from the mixing water. A caliche-like bond between grains forms as the mud slowly dries (Austin, 1990). The clay component on the surface of most vertical adobe surfaces limits the penetration of precipitation; water runs off before it can soak into the wall and erosion is limited in New Mexico to "1 inch in 20 years" (P. G. McHenry, Jr., written comm. 1992). This assumes a "reasonable" amount of clay because an adobe soil with very little clay will erode very rapidly in a driving rainstorm. On a horizontal adobe surface, however, moisture tends to puddle and soak in; then subsequent raindrops physically damage the softened surface.

Leaching tests with EDTA (ethylenedinitrilotetraacetic acid) on 25 commercial New Mexican adobe soils suggest that commercial soils contain an average of about 90 wt.% insoluble and 10 wt.% soluble material; the latter is dominantly calcite and some gypsum (Austin, 1990). In that study, the soluble material ranged from 36 wt.% to essentially zero. Adobe soils with the smallest amount of soluble material were also the highest in sand and larger-size particles. A study of a limited number of adobes from other parts of the world found a similar range of soluble material (Coffman et al., 1990).

### Physical properties

**Particle-size distribution—Adobes** from some historic structures in the American Southwest and other parts of the world have clay contents from 1 to 38 wt.%, while sand-and-larger particles range from 4 to 82 wt.% in a limited number of samples (Coffman et al., 1990). The common statement by modern New Mexican adobe producers is that their soil mix is usually one-half sand and one-half "clay" or "fines" (silt and clay); however, commercial adobe soils in New Mexico range from 85 to 99 wt.% nonclay-size particles (Smith and Austin, 1989). Tests of commercially produced New Mexican adobes show that particle sizes of the soil varies widely. They contain 27-89 wt.% sand-and-larger grains, 8 to 68 wt.% silt-size grains, and 1-15 wt.% clay-size grains. The average grain-size composition was 67 wt.% sand-and-larger, 27 wt.% silt, and 6 wt.% clay.

Large-scale commercial adobe producers in New Mexico use adobe soils with less clay-size material than do small-scale commercial and non-commercial adobe producers. Some of the former are as low as approximately 1 wt.% clay, whereas many of the latter are between 8 and 15 wt.% (Smith and Austin, 1989). In part this is because large-scale commercial adobe producers

use stabilizers that not only protect blocks from rain damage but aid in consolidation of the drying soil mix as well. An abundance of clay-size particles in adobe soils causes excessive cracks as blocks dry in an adobe yard. To combat cracking, producers add straw and/or additional sand to the mud mixture.

**Thermal properties—Traditionally,** materials are evaluated for thermal properties based on measurements known as R- and U-values. The R-value is an indicator of the ability of a wall to insulate effectively and is calculated by dividing the thickness of the wall by the wall's thermal conductivity, the amount of heat flowing from the warmer to the cooler side of the wall. The U-value is the reciprocal of the R-value and reflects the rate at which heat is conducted through a material. The total R-value may be calculated for a given wall by adding up the values of the individual components of a wall structure, including all insulation, interior sheathing, framing, air-space resistance, and masonry. Adobe walls have very low R-value because they commonly consist of 10 or 14 inch blocks covered with a thin stucco on the outside and thin gypsum plaster on the inside.

However R- and U-values do not tell the full story in determining what is a high-quality, thermally efficient wall (Fine, 1976). Both these values reflect the rate at which heat passes through a wall only after a steady state of heat flow (heat energy is passing uninterrupted from one side of the wall to the other at a constant rate) has been achieved. What is not considered, and is of critical importance in masonry-mass walls such as adobe, is the heat storage capacity of the wall, which determines the length of time that passes before a steady state of heat flow is achieved. The higher the heat storage capacity of the wall, the longer period of time it will take for heat flow to reach a steady state. In real situations external temperatures change constantly, so that a true steady-state condition is rarely achieved. Because diurnal changes in the arid Southwest are typically 15-25°C, the "fly-wheel effect" keeps adobe buildings' daytime temperatures cool in the summer and warm in the winter.

**Resistance to sound—The** thick walls of a typical adobe are well-known sound deadeners, making these homes remarkably quiet. Windows in older adobe buildings are normally small, further adding to the quietness. Newer solar adobe homes take advantage of the many sunny days in arid climates with large windows, but use well-insulated glass to retain much of the sound-deadening characteristics of adobe dwellings.

**Other physical properties—Adobe** homes are water resistant, flame retardant, unaffected by termites, and energy efficient. In addition to the preservation of nighttime cool temperatures in the summer and daytime heat in the winter, the sun-dried method of production, rather than using high heat to produce masonry brick or cement, increases the original energy efficiency. Wright (1978) stated that it takes over 300 times more commercial energy to produce a concrete block than a sun-dried adobe block of equal volume.

### Technology

The principal standard-size adobe brick produced and used in New Mexico measures 4 x 10 x 14 inches and weighs approximately 30 lbs (Smith and Austin, 1989). Several varieties and sizes of earthen brick are produced throughout the American Southwest; these include traditional adobe, semistabilized and stabilized adobe, New

Mexican terrónes (cut-sod brick), quemados (burnt adobe), and machine-pressed-earth block; in addition, rammed-earth walls are constructed without adobe brick (McHenry, 1984; Smith and Austin, 1989). The major type of adobe brick currently produced commercially in New Mexico is the semistabilized adobe. Traditional adobe brick and stabilized adobes are available on special order. In Arizona the most common adobes are stabilized, and traditional or unstabilized adobes are all but impossible to find (P. G. McHenry, Jr., written comm. 1992).

### Production techniques

**Traditional (untreated) adobe bricks**—Often called untreated or sun-dried adobe brick, traditional adobe is made with soil composed of sand with some larger-size particles, and of silt and clay. Straw is sometimes added for strength and to prevent excessive cracking during drying. The moistened soil mixture commonly is packed into a brick-like mold, released, and allowed to dry and "cure" for several weeks before use.

**Stabilized adobe bricks**—Fully stabilized adobe brick is defined by the New Mexico Building Code as water-resistant adobe made of soil with certain admixtures that limit the brick's seven-day water absorption to less than 4 wt.%. A fully stabilized adobe brick usually is made with 6-12 wt.% of asphalt emulsion (California Research Corporation, 1963; Scheuch and Busch, 1988). Asphalt emulsion is the primary stabilizer because of the ease of use and the low cost, but 5-10 wt.% portland cement produces the same result.

Exterior walls constructed with stabilized mud mortar and brick require no additional protection and can be left exposed without stucco. The production of fully stabilized adobe brick is very low because most walls are stuccoed with water-resistant plaster, and the additional waterproofing agent adds extra cost.

**Semistabilized adobe bricks**—Semistabilized adobe brick was developed by major adobe producers in New Mexico and is classified as a water-resistant brick because of the addition of 3-5 wt.% of a stabilizer or water-proofing agent (California Research Corporation, 1963; Scheuch and Busch, 1988). The stabilizer protects the brick from rainstorm damage during the curing process. Semi-stabilized adobe is made the same way as traditional adobe, except for mixing the stabilizer into the adobe soil prior to packing it into a form. It is the most common commercial mud block made in New Mexico, accounting for between 60 and 80% of total commercial production (Figs. 2 and 3).

**Pressed-earth blocks**—Pressed-earth blocks presently make up a small portion of earth brick used in New Mexico (Smith and Austin, 1989). The CINVA-Ram, a hand-operated press, was developed by a Chilean engineer in the 1950s and has been used in the state, but most pressed-earth blocks are made by gasoline- or diesel-powered machines (Fig. 4). Several have been designed and used in the past in New Mexico to press the adobe soil mixture into a form, minimizing the amount of time required between forming the block and placing it into the wall. Portland cement or asphalt emulsion has been used to partly stabilize or fully stabilize pressed-earth blocks. Most pressed-earth blocks come from small-volume and/or part-time, or non-commercial producers.

**Rammed-earth walls**—Rammed-earth homes commonly have much thicker walls than most other earthen dwellings, up to 36 inches thick. Wooden or metal con-



FIGURE 2—Commercial adobe production at New Mexico Earth, Alcade, New Mexico. The front-end loader delivers the semistabilized mud mixture to wooden 10 mold ladder forms. After a few hours, the forms can be removed, leaving the adobes to dry for two to three days, after which they are trimmed and turned on the side to dry for another 10 days to two weeks.



FIGURE 3—Mechanical adobe layer that produces 25 standard-size adobe bricks per laydown. Medina's Adobe Factory adobe yard, Alcade, New Mexico.



FIGURE 4—Earth Press III pressed-earth-block machine set up near wall under construction. Coyote Adobe Inc. building site, Velarde, New Mexico.

crete-type forms are put in place on stone or concrete footings and 6 to 8 inch thick layers of moistened soil are put between the walls of the forms. Hand or hydraulic tampers are used to pound the soil into the shape of the form, compacting and reducing the volume of the mixture by 25-30% (McHenry, 1984; Middleton, 1987; Fig. 5). Once the layers of tamped soil reach the desired height, the forms are removed and the wall is allowed to dry (Fig. 6). Portland cement is the commonly used stabilizer. Producers say rammed-earth walls continue to harden, or cure, during the first year after construction. During 1994 the state's two rammed-earth construction firms built 11 homes.

### Specifications

Specifications for adobe or mud construction are not widely used in the United States. New Mexico, the state with the most adobe construction, probably has the most complete approach. The New Mexico code for unburned clay masonry is Section 2413 of the New Mexico Building Code (Construction Industries Division, 1991). The most significant rules regarding adobe blocks can be summarized as follows:

1. *Compressive strength:* The units shall have an "average compressive strength of 300 lbs/inch<sup>2</sup>" when tested.
2. *Modulus of rupture:* This unit shall "average 50 lbs/inch<sup>2</sup>" in modulus of rupture when tested according to the specified procedures.
3. *Moisture contents:* The moisture content of untreated units shall not be more than 4%.
4. *Absorption:* A dried cube cut from a sample shall not absorb more than 4% moisture by weight when placed upon a constantly water-saturated porous surface for seven days. An adobe unit that meets this specification shall be considered "stabilized."
5. *Shrinkage cracks:* No unit shall contain more than three shrinkage cracks, and no shrinkage crack shall exceed "2 inches in length or 1/8 inch" width.

### Economic factors

#### Cost

In New Mexico adobe brick production varies from a labor-intensive traditional hoe-shovel-and-wheelbarrow technique to a mechanical large-scale operation producing 5,000-20,000 bricks per day. The production of adobe bricks is seasonal and is usually limited by the number of frost-free days for a particular adobe yard. The production season in New Mexico lasts from five to nine months, depending on climate and weather conditions.

Smith and Austin (1989) reported that producers using the handcraft technique for traditional (untreated) adobe marketed their products at 21-40 cents per brick at their yards. One-person commercial yards produced 100-300 bricks per day. Semimechanized adobe yards with 8-10 employees can produce 5,000-6,000 semi-stabilized bricks per day that are sold for 40-45 cents per brick at the yard (E. W., Smith, written comm. 1992). This year (1995) the largest mechanized adobe yard with 3-4 employees can produce 5,000-7,000 semistabilized adobes per day that are sold for 38-45 cents at the yard. Most producers say that the stabilizers (asphalt emulsion and portland cement) add between 5 and 10 cents to the price of an adobe. Adobe bricks can be delivered to the job site via flat-bed trucks that carry up to 1,000 palletized or stacked adobes. A 1,000 to brick load would weigh 16-18 st; typical adobe haulers use 2-3 st trucks.

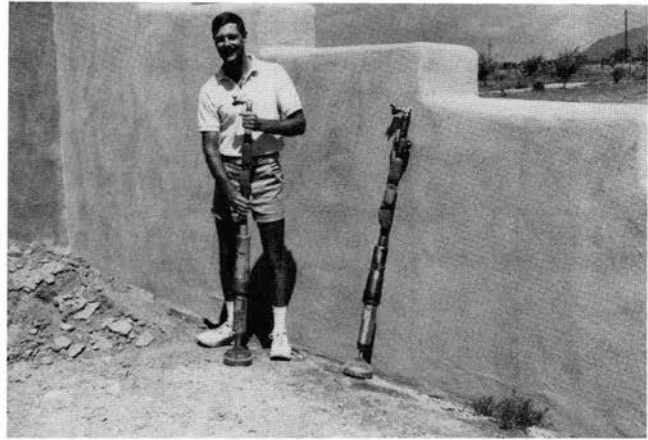

FIGURE 5—Stan Huston standing in front of a rammed-earth wall and holding one of the Ingersoll Rand 341 backfill tampers that are hooked up to 125 Schramm compressor for tamping rammed-earth walls. Huston Construction Company building site, Edgewood, New Mexico.



FIGURE 6—Thick rammed-earth walls after forms have been removed at Huston home near Edgewood, New Mexico, with a freshly poured concrete bond beam. Note tamped soil layers with different amounts of water. When completely dry, the walls will be nearly the same color, but layers will remain variable due to differences in grain size. After stucco is applied, the walls will appear monolithic.

Pressed-earth blocks in a production yard are sold for comparable prices, but some producers take their machine to the job site and use local soil for their blocks at a slightly reduced price. These producers are also contractors who will build the desired walls or a complete house.

### Transportation

Adobe may be made on the construction site, but in recent years it is more likely to be made in adobe yards and transported to building sites on flat-bed trucks (Fig. 7). Although transport to distant construction sites is uncommon, some producers ship adobes several hundred miles. The problem is normally not in the availability of the raw material. Acceptable, if not superior, adobe can be made with most native raw materials, providing a qualified adobe maker is involved. Long-distance shipping occurs when the landowner wants an adobe home and contractors in the immediate area have neither the training nor the talent for this type of construction.

Rammed-earth construction methods require that the

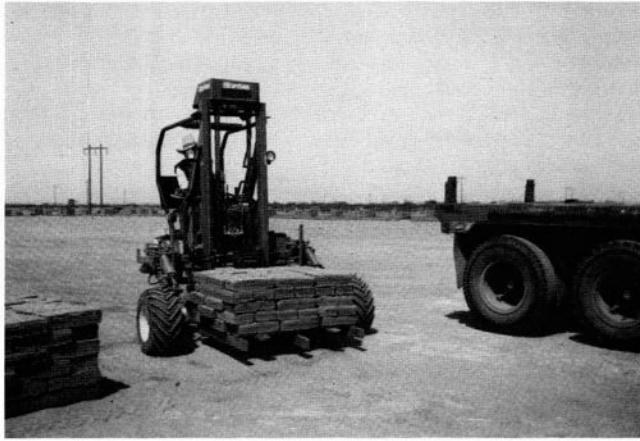

FIGURE 7—Spyder forklift loading adobe bricks onto flatbed truck. After adobes have been stacked onto wooden pallets, only one employee is required to deliver the pallets. The forklift can be fitted into a cradle built into the flatbed, where it is carried to the construction site to unload the adobe bricks.

walls be made at the building site. Consequently, the normal method of construction is to use local materials or materials that have not been transported far.

#### Health and safety regulations

The identification of radon gas as a health hazard in homes and the low-strength materials used in adobe homes in seismically active areas have caused owners to be concerned about the safety of their adobe structures. Modest changes in construction and care commonly will prevent problems in all but the most severe cases (Smith and Austin, 1989).

**Radon accumulation**—Radon is a colorless, odorless, heavier-than-air radioactive gas derived from the breakdown of some radioactive elements in soil and rock. The most stable radon isotope,  $^{222}\text{Rn}$  has a half-life of 3.8 days (Wilkening, 1980). Radon enters buildings through cracks, particularly when the buildings are closed and have a negative air pressure, as is commonly true during the heated winter months, and accumulates in low spots. Although adobe buildings have not been shown to have significantly more radon than other types of dwellings, good ventilation and positive interior air pressure are the easiest ways to prevent a buildup of the gas.

**Seismic activity**—Earthquakes are very destructive in many parts of the world where low-strength masonry is used. Adobe buildings in the United States are commonly constructed with one and two stories, and on concrete slab foundations. Designing the slab to resist cracking during both the normal life of the structure and possible earthquakes is prudent in seismic areas. Recent work in California suggests that a combination of proper slab construction, reinforcing walls with rebar, using wire mesh both inside and outside the building beneath the plaster and stucco, interconnected bond beams and roof beams at the top of walls, and buttresses can reduce earthquake damage (Tibbets, 1986).

The building code for earthen construction is concerned with safety for the inhabitants. In New Mexico and California, two states with significant numbers of adobe structures and seismic activity, the building code specifically addresses the need for adobe structures to endure considerable earth movements during seismic events (Smith and Austin, 1989). The New Mexico code forbids the con-

struction of adobe structures exceeding two stories in height. All bearing walls must be topped with a continuous belt course or tie beam. The belt course is commonly reinforced concrete and tie beams are solid wood at least six inches thick. The California building code requires that walls have internal reinforcement with rebar as well. The result is that during seismic events adobe structures fare about as well as buildings constructed with other materials. Some California building code regulators also allow the flexibility of substitution of some horizontal for some vertical reinforcement in earth construction (P. G. McHenry, Jr., written comm. 1992).

#### Energy used in construction of adobe buildings

Adobe construction is an environmentally friendly process if the embodied heat represented in the making and transport of various types of building materials is considered. Most studies in the past have dealt with the insulating properties and energy required per unit volume to heat of different building materials, and adobe ranks poorly in these categories. However, by virtue of its construction methods, adobe has definite advantages in terms of resource consumption. Adobe is made primarily from soil, little energy is involved in the exploration for it and no energy is invested in the refinement of adobe soils. Adobe is often made from the soil on-site and the energy involved in transport is negligible.

In 1976 the Energy Research Group, University of Illinois, and the architectural firm of Richard G. Stein and Associates (as reported by McHenry, 1984) performed a comprehensive study of the embodied energy represented in different building materials. Some of the values from the study follow (first five lines), showing the amount of heat expended in Btu's. Adobe was not involved in this study, but if measured the same way (values added to figures), its value would be far less:

Material	Unit	Btu's Used
Portland cement	94 lb sack	381,624
Lime, hydrated	100 lb sack	440,619
Common brick ( $2\frac{1}{4}'' \times 3\frac{5}{8}'' \times 7\frac{5}{8}''$ )	1 brick	13,570
Paving brick ( $2\frac{1}{4}'' \times 3\frac{5}{8}'' \times 7\frac{5}{8}''$ )	1 brick	24,306
Concrete block ( $8'' \times 8'' \times 16''$ nominal)	1 brick	29,018
Adobe brick ( $4'' \times 10'' \times 14''$ ) (produced by off-site mechanized laying machine)	1 brick	2,500

With this study in mind, it can be seen that adobe construction can lead to considerable saving in energy-resource use. In addition, if the adobe is constructed from material on the building site, further savings in energy can be made because transportation of materials can be avoided.

As noted above, adobe walls have very low R-values because they commonly consist of 10 or 14 inch blocks covered with a thin stucco on the outside and thin gypsum plaster on the inside. However the higher heat-storage capacity of an adobe wall means that it will keep adobe buildings' daytime temperatures cool in the summer and warm in the winter. With modern materials and techniques, such as using solar heating, modern adobe buildings avoid using considerable energy during their construction and are very comfortable and efficient when completed.

If over 300 times more commercial energy is necessary

to produce a concrete block than a sun-dried adobe block (Wright, 1978), adobe is inherently less demanding of energy resources. Adobe, first used because of the paucity or costs of the more conventional local construction materials, should now be used because of its lower energy consumption during production and its continued low-energy demand during use.

#### Problems and future trends

Adobe and similar earth construction are gaining respectability, particularly in the American Southwest, as the Santa Fe Style construction remains popular. Earth construction will continue to account for 2-5% of the homes constructed in this region for the foreseeable future. It also will be the preferred construction of the low-income and high-income groups. Low-income groups use this construction because local materials are available and they can build the structures themselves, often in their spare time. Adobe is also the preferred type of construction for the wealthy because a superior home can be constructed that is "in harmony with nature" and currently chic.

#### References

- Anderholm, S. K., 1987, Hydrogeology of the Socorro and La Jencia Basins, Socorro County, New Mexico: U.S. Geological Survey, Water Resources Investigation Report 84-224, 62 pp.
- Austin, G. S., 1990, Adobe and related building materials in New Mexico, USA: Adobe 90 Preprints, 6th International Conference on the Conservation of Earthen Architecture, The Getty Conservation Institute, Los Angeles, pp. 417-423.
- Austin, G. S., 1995, Construction uses: Adobe and similar materials; *in* Carr, D. D. (ed.), Industrial minerals and rocks, 6th ed., Society for Mining, Metallurgy, and Exploration Inc., Littleton, Colorado, pp. 279-286.
- California Research Corporation, 1963, The manufacture and use of asphalt emulsion stabilized adobe bricks: California Research Corporation, Richmond, California, 17 pp.
- Chamley, H., 1989, Clay sedimentology: Springer-Verlag, Berlin, 623 pp.
- Coffman, R., Agnew, N., Austin, G., and Doehne, E., 1990, Adobe mineralogy: Characterization of adobes from around the world: Adobe 90 Preprints, 6th International Conference on the Conservation of Earthen Architecture, The Getty Conservation Institute, Los Angeles, California, pp. 424-429.
- Construction Industries Division, 1991, New Mexico Building Code: Construction Industries Division, General Construction Bureau, Santa Fe, New Mexico, Part V, pp. 31-36.
- Dethier, J., 1985, A back to earth approach to housing: UNESCO Courier, March, pp. 31-33.
- Ferm, R. L., 1985, Stabilized earth construction: An instructional manual: The International Foundation for Earth Construction, Washington, DC, 74 pp.
- Fine, A. H., 1976, The thermal properties of building materials: Adobe News, Albuquerque, New Mexico, no. 11, pp. 14, 26.
- Gerbrandt, H., and May, G. W., 1986, The extent of adobe use in the United States: Solar Earthbuilder International, Las Cruces, New Mexico, Issue 47, pp. 12-15, 56-59.
- Hawley, J. W., 1994, Some principles of calicisol development and soil-geomorphic relationships in southeastern New Mexico: New Mexico Geological Society, Guidebook 44, pp. 4-5.
- McHenry, P. G., Jr., 1984, Adobe and rammed earth building Design and construction: John Wiley & Sons, New York, 217 pp.
- McHenry, P. G., Jr., 1985, Adobe, build it yourself, rev. ed.: University of Arizona Press, Tucson, Arizona, 158 pp.
- Middleton, G. F., 1987, Earth-wall construction, 4th ed., (rev. by L. M. Schneider): Australian Government Publishing Service, National Building Technology Centre, Bulletin 5, 65 pp.
- Potter, P. E., Heling, D., and Shimp, N. F., 1975, Clay mineralogy of modern alluvial muds of the Mississippi River basin: Bulletin du Centre de Recherches de Pau., v. 9, pp. 353-389.
- Scheuch, K. E., and Busch, R. D., 1988, New Mexico Conservation Code Application Manual, Residential Buildings, 1988 ed.: Energy, Minerals, and Natural Resource Department, Santa Fe, New Mexico, 108 pp.
- Smith, E. W., and Austin, G. S., 1989, Adobe, pressed-earth, and rammed-earth industries in New Mexico: New Mexico Bureau of Mines and Mineral Resources, Bulletin 127, 60 pp.
- Tibbets, J. M., 1986, Of major importance to every earthbuilder: Solar Earthbuilder International, Las Cruces, New Mexico, Issue 47, pp. 26-29, 64.
- Wilkening, M., 1980, Radon transport processes below the earth's surface: Natural Radiation Environment III, Technical Information Center/U.S. Department of Energy, Washington, DC, CONF-780422, v. 1, pp. 90-104.
- Wilkins, D. W., 1986, Geohydrology of the Southwest alluvial basins regional aquifer-systems analysis, parts of Colorado, New Mexico, and Texas: U.S. Geological Survey, Water Resources Investigation Report 84-4224, 61 pp.
- Wright, D., 1978, Natural solar architecture: Van Nostrand Reinhold, New York, 245 pp.

# Travertine in New Mexico— Commercial deposits and otherwise

James M. Barker<sup>1</sup>, George S. Austin<sup>1</sup>, and David J. Sivils<sup>2</sup>

<sup>1</sup>New Mexico Bureau of Mines & Mineral Resources, New Mexico Tech, 801 Leroy Place, Socorro, NM 87801-4796, USA

<sup>2</sup>Department of Earth and Environmental Science, New Mexico Tech, 801 Leroy Place, Socorro, NM 87801-4796, USA

**Abstract**—Travertine is composed of low-magnesian calcite formed in freshwater through organic or inorganic processes. The nature of travertine deposited by springs is the result of water chemistry, water temperature, and local conditions. Harsh conditions favor the formation of inorganic travertine whereas organic travertine exists in more moderate environments. Inorganic travertine often forms near a spring orifice with organic deposition farther away as conditions moderate.

Travertine deposits are categorized by morphology, constituents, and internal stratification. The classes are: (1) waterfall/cascade; (2) lake-fill; (3) sloping mound, fan, or cone; (4) terraced mound; and, (5) fissure ridge. All of these are present among the approximately 55 discrete travertine deposits currently described in New Mexico. Numerous undocumented, minor deposits occur in the extensive limestone terranes of southeastern New Mexico. Travertine is frequently associated with local faults that channel carbonate-bearing waters to surface springs. Thus, most of the deposits in New Mexico are associated with the Rio Grande rift or structures, such as the Jemez volcanic zone, that intersect it.

Travertine has many uses as a decorative or ornamental stone. Commercial travertine is hard, dense, finely crystalline, compact, massive to color banded, and takes a polish. New Mexico Travertine (NMT), the sole producer in New Mexico, has operated a quarry and dressing plant west of Belen since the early 1980s. They slab and process 1,000-3,000 ft<sup>2</sup> per day of stone using their own travertine (20%), on contract (25%), or using stone purchased from other states (55%), primarily Indiana, Texas, Oklahoma, and Kansas. Contracted or purchased stone, primarily limestone, are also dressed on the NMT tile line. When fully operational, the tile line, which is the only one in the western United States, will have a capacity of 2,000 ft<sup>2</sup> per day. About 90% of NMT production is trucked to California, Utah, or the east coast primarily for use in residences.

## El travertino en Nuevo Mexico- Yacimientos económicos y no económicos

**Resumen**—Travertino es caliza de bajo contenido de magnesio. Se forma en agua dulce (vertientes) por procesos orgánicos o inorgánicos. Las características del travertino dependen de la composición química y la temperatura de las aguas, así como de condiciones locales. Travertinos inorgánicos se forman en ambientes desfavorables para procesos biológicos, por ejemplo alrededor del orificio de salida de una vertiente, mientras que a cierta distancia de la boca, al moderarse las condiciones fisicoquímicas, aparece el travertino orgánico.

Los depósitos de travertino se clasifican por su morfología, componentes y textura (estratificación interna). Las clases son: (1) travertino de cascada; (2) depósito lacustre; (3) montículo en faldeo (*sloping mound*), abanico o cono; (4) yacimiento de terraza y (5) depósito elongado de fisura (*fissure ridge*). Todas estas variedades se encuentran entre los yacimientos de travertino, unos 55 en número, que se han descrito en Nuevo Mexico. Hay, además, numerosos depósitos menores, no documentados, en los extensos terrenos calcáreos del sureste del estado. Muchas veces, el travertino se halla asociado con fallas locales que sirven de conductor para aguas cargadas de carbonato que alimentan las vertientes. Es así como la mayoría de los yacimientos en Nuevo Mexico se encuentran en el *rift* del Rio Grande o en estructuras que lo penetran.

El travertino tiene muchos usos como piedra ornamental. Travertino comercial es duro, denso, criptocristalino, compacto, de color sólido o con bandas de color, y puede ser esmerilado y pulido. La empresa *New Mexico Travertine (NMT)* es la sola productora en el estado. Desde los primeros años del 1980 esta empresa ha operado una cantera y planta procesadora al oeste de Belen. Cortan y procesan de 1,000 a 3,000 pies cuadrados por día. De este total, el 20% proviene de cantera propia, el 25% se procesa por cuenta ajena, y el 55% es piedra comprada de afuera, principalmente de Indiana, Texas, Oklahoma y Kansas. NMT cuenta con una nueva línea de fabricación de baldosas donde también se trabaja piedra por cuenta ajena o piedra comprada de afuera, mayormente calizas. Una vez que esa instalación, la (mica de su género en el oeste del país, opere a capacidad máxima, podrá producir hasta 2,000 pies cuadrados diarios de baldosa. Un 90% de la producción es transportado por camión de carga a California, Utah, o a la costa atlántica, donde se usa principalmente en la construcción de viviendas.



Introduction

Travertine is low-magnesian calcium carbonate (CaCO<sub>3</sub>) as calcite and less commonly as aragonite (a higher temperature form of calcite) deposited in freshwater by organic and inorganic processes. In broad terms, travertine is calcium carbonate deposited in a spring system that emits either warm or cold calcium-charged water and deposits calcium carbonate at or near the spring orifice. Spring waters far from the orifice typically deposit as carbonate cements rather than recognizable travertine. Precipitation of calcium carbonate in a spring system occurs when bicarbonate-rich waters become supersaturated due to

evaporation or loss of CO<sub>2</sub> by degassing upon pressure release, turbulence, or organic activity. The latter includes floral photosynthesis, principally by algae, mosses, or hepatica (Julia, 1983; Fisher, 1979), and by bacterial metabolism (Folk, 1993; Chafetz and Folk, 1984).

Travertine is frequently associated with faults and with nearby limestone source rocks. The faults provide a pathway to the surface for carbonate-charged spring water that has interacted with the carbonate. Many of the travertine deposits in New Mexico are associated with the Rio Grande rift or structures intersecting it such as the Jemez volcanic zone (Fig. 1). Additional undescribed de-

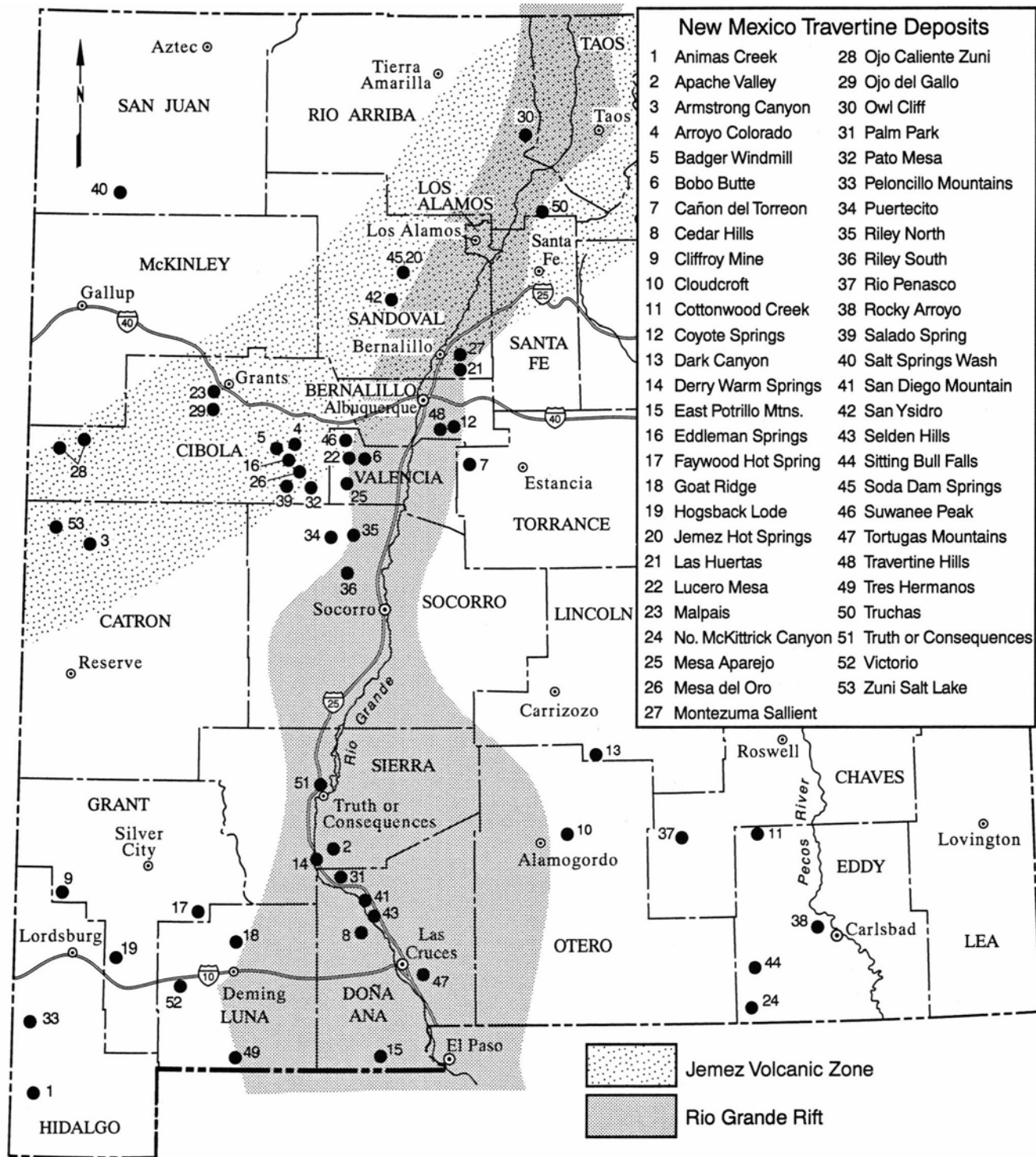

FIGURE 1—Location of travertine deposits in New Mexico and their positions relative to the Rio Grande rift and the Jemez volcanic zone.



posits, which are likely to be small, are found in the extensive limestone terranes of southeastern New Mexico.

The nature of a travertine deposit is the result of local conditions that include climate, geology and physiography, water chemistry, water temperature, and deposit history. Harsh conditions favor the formation of travertine through inorganic precipitation whereas organically formed travertine dominates in more moderate environments (Chafetz and Folk, 1984). Commonly, inorganic travertine will form near an active spring and organic travertine will form at a greater distance from the spring orifice. Spring-derived carbonate waters may percolate into and cement surficial materials. Thus, the range of spring carbonate derived structures and rock types is quite wide.

Commercial travertine is hard, dense to vuggy, finely crystalline, compact, massive to color-banded limestone that takes a polish. Impurities in travertine impart colors ranging from white to pink, tan, yellow brown, or dark brown. If variable impurities cause color banding in layered travertine, the stone is sometimes called tufa, calcareous sinter, marble, Mexican onyx, or onyx marble (Sanders and Friedman, 1967); true onyx is banded silica ( $\text{SiO}_2$ ) rather than calcite. Travertine, as quarried and marketed by New Mexico Travertine (NMT), includes all forms of calcite, aragonite, travertine, Mexican onyx, carbonate breccia, and altered limestone bedrock with oxidized iron on stylolitic surfaces that occur in their highly variable quarries.

The preferred color in commercial travertine applications is white, bone, or beige. These colors corresponding to the majority of imported travertine, chiefly from Italy, and to insure compatibility with stone used previously. More variegated varieties are used in special commercial and governmental applications and in private homes.

This report expands an earlier report by Austin and Barker (1990) that examined the operation of New Mexico Travertine (Fig. 2), the only travertine producer in New Mexico. Since that report and although production of New Mexico travertine has decreased in volume, the company has expanded and now cuts and finishes rocks from many other quarries in other states in addition to its own travertine.

### Travertine classification

The classification developed by Chafetz and Folk (1984) categorizes travertine deposits based on morphology, constituents, and internal stratification (Table 1). The categories include: (1) lake-fill, (2) terraced mound, (3) sloping mound, fan, or cone, (4) waterfall/cascade, (5) fissure ridge, and (6) other. Travertine classification becomes increasingly difficult to apply to inactive deposits as they weather and erode. Therefore, most deposits described below have not been classified pending detailed field work.

### Shallow lake-fill deposits

The shallow lake-fill travertines form in very shallow water often no deeper than 3 ft. The travertine is in nearly horizontal strata that are often separated by mud or terrigenous sediment. Desiccation cracks are abundant in these deposits. This implies a very shallow lake subject to frequent episodes of water-level fluctuations possibly as the result of travertine rimstone-dam formation and collapse.

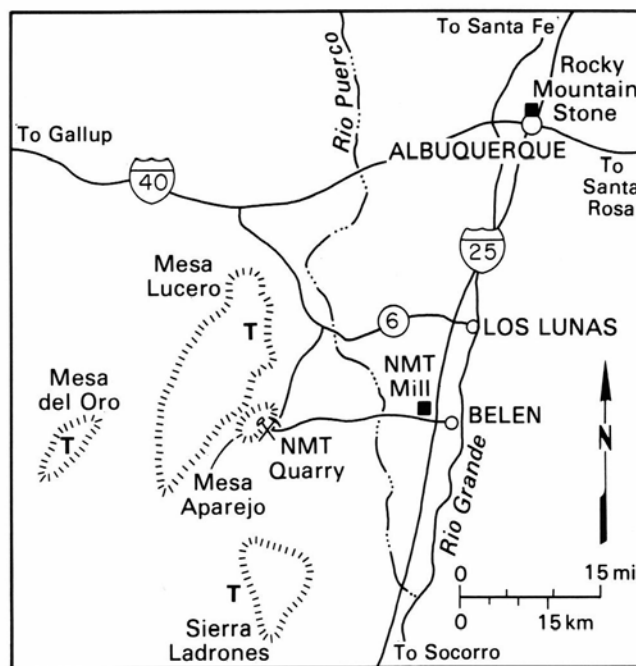

FIGURE 2—Location map of Mesa Aparejo region in central New Mexico. “NMT Quarries” is the site of New Mexico Travertine quarries and “NMT Mill” is the dressing and tile plant. “Rocky Mountain Stone” is the retail outlets for NMT travertine and other stone. “T” indicates travertine occurrence discussed in text and shown in Figure 1.

Shallow lake-fill travertine deposits have very gently sloping profiles due to their deposition in quiet waters. Shrub-like masses of vertically aligned calcite crystals of biological (bacterial?) origin are a common occurrence in these lake deposits.

### Terraced mounds

The depositional surfaces in terraced mound deposits are typically irregular. The terraced appearance of these deposits is a result of water flowing over the rimstone-dam edges of small pools and cascading into pools below. The number of stacked terraces can be large and most of the famous travertine deposits, such as those at Yellowstone National Park, are of this type.

### Sloping mounds, fans, and cones

The mound, fan, and cone travertine deposits are similar in appearance to one another but distinctly different from lake deposits. Collectively, these travertines have slopes that dip away from a central spring orifice. The boundaries between layers appear to be more the result of non-deposition than of erosion. The individual lithologic units in a fan deposit pinch out laterally usually yielding a convex-up structure for the entire travertine package.

### Waterfall/cascade deposits

Travertine in the waterfall/cascade type is deposited because of the agitation of spring water as it tumbles down waterfalls and steep rapids. Water agitation enhances loss of  $\text{CO}_2$  thus aiding carbonate precipitation. The convoluted morphology of waterfall and cascade deposits yields excellent sites for the attachment and growth of algae and mosses. The increased surface area of this deposit type provides ideal sites for bacterial at-

TABLE 1—Tabulation of the classification of travertine types of Chafetz and Folk (1984).

TYPE	CLASS	STRUCTURAL ELEMENTS	CARBONATE MORPHOLOGY	DOMINANT BIOTA	SIZE	DEPOSITION RATE	EROSION	REMARKS
Lake fill	1	thick, horizontal strata; massive	shrubs/laminated mud; pisoids, rays, intraclasts [foam rock, lenses, pisoids]	bacteria	very large	slow synchronous	whenever dam is breached lowering lake level	generally less than 3 ft deep; laterally extensive
Terraced mound	2	rimstone dams and pools; step-like	rays (rimstone) shrubs (pool) [pisoids]	bacteria	large	moderate diachronous	varies over surface as flow migrates	classical Yellowstone type
Mound, fan, cone	3	complex layers; stratification parallels slope	intraclasts and particulates [rays] [shrubs]	algae blue green	large	rapid diachronous	common over most of deposit except in active channels	dipping, erosional surfaces; radial dip; channel flow changes location or ceases often
Waterfall, cascade	4	vertical curtains or sheets; crusts	encrustations of tubes in tangled irregular masses	algae & mosses	small	very rapid diachronous	during floods	few bacteria owing to non-sulfide water; tend to form at sites of previous waterfalls, rapids slope breaks or riverine boulder accumulations; often closely resemble speleothems
Fissure ridge	5	convex up; elongate drapes from axial springs	complex	algae & mosses	small	rapid synchronous	breaching after damming	can form a dam with lake behind
Other	6		often combinations of types 1-5				typically extensive masking origin	highly variable

tachment. This organic activity removes CO<sub>2</sub>, thereby further enhancing the formation of travertine.

### Fissure ridges

Spring waters emanating along a fault or fracture often form small (typically 300 ft long) elongate travertine deposits. In addition to visible water along the fault, microterraces are common on sloping surfaces. Fissure ridge travertine may form dams leading to lake-fill deposits (Chafetz and Folk, 1984), or they may have associated terrace mounds.

### Other

Travertine deposits of unknown origin are placed in the "other" category. Commonly, they have highly variable morphology and nondiagnostic internal characteristics.

## Selected travertine deposits of New Mexico

Travertine is widespread in New Mexico (Kottlowski, 1965). About 50 discrete deposits are reported in the literature (Barker, 1986, 1988) with many additional unreported occurrences in the extensive limestone terrains of southeastern New Mexico (see Dark Canyon, Cloudcroft, and North McKittrick Canyon deposits described below for examples). Most deposits are associated with the extensional Rio Grande rift or the Jemez volcanic zone that intersects it (Fig. 1). The extensional volcanic terrane in the Basin and Range province of southwestern New Mexico also has numerous deposits.

New Mexico Travertine (NMT) of Belen, New Mexico, produces travertine from quarries on Mesa Aparejo (secs. 12 and 13 T5N R3W). These quarries were operated intermittently prior to NMT operations along with several others along the Comanche thrust between the Sierra Ladrones and New Mexico Highway 6 (NM-6). Other large occurrences (Fig. 1) are west of Sierra Ladrones (Barker, 1983) and at Mesa del Oro (Jicha, 1956, 1958). Minor production of travertine occurred at several other deposits as described below.

The following section briefly describes the travertine deposits in New Mexico as shown by number on Figure 1. The deposits most likely to be economically viable in the future are: Mesa Aparejo (25), Mesa del Oro (26) Riley North (35), San Ysidro (42), and Lucero Mesa (22).

### 1. Animas Creek (sec. 35 T20W R30S, Hidalgo Co.)

The Animas Creek travertine deposit is inactive (Summers, 1976). It is near Animas Creek on the Animas Peak NE 7.5 minute quadrangle.

### 2. Apache Valley (sec. 6 T17S R3W, Sierra Co.)

The Apache Valley deposit is described by Kottlowski (1962) as a 40 ft thick mound-like mass of high-calcium limestone southeast of Caballo Lake. The host rock in this location is the Eocene Palm Park Formation, consisting of volcanoclastic and alluvial sedimentary rocks with interbedded nonmarine limestones and travertines in the middle to upper part of the formation (Fitzmaurice, 1990). The travertine mounds represent many depositional environments and are mostly calcite except for some aragonite in paleo-spring orifices. Palm leaf molds and stromatolites are abundant and seasonal sparry (spring-summer) and micritic (fall-winter) laminations are integral to the travertine deposits (Chafetz, Utech, and Fitzmaurice, 1991). This deposit is on the McLeod Tank and surrounding 7.5 minute quadrangles.

### 3. Armstrong Canyon (T1-2N R17W, Catron Co.)

Travertine deposits cap ridges northwest of Armstrong Canyon (S. M. Cather, New Mexico Bureau of Mines and Mineral Resources, pers. comm., 1992). This deposit may be widespread between Armstrong and Amen Canyons and is on the Armstrong Canyon 7.5 minute quadrangle.

### 4. Arroyo Colorado (E1/2 sec. 20 T7N R5W, Cibola Co.)

A travertine or tufa deposit covers about 0.6 mil northeast of Alkali Spring and east of Arroyo Colorado near the Crane Place on the Marmon Ranch 7.5 minute quadrangle (Maxwell, 1988). The Eddleman Spring and Badger Windmill deposits are about 3 mi southwest and west of this deposit, respectively.

### 5. Badger Windmill (NE1/4 sec. 26 T7N R6W, Cibola Co.)

A small tufa and travertine is being deposited around Badger Windmill by an active spring (Maxwell, 1988). This deposit is about 3 mi northwest of the Eddleman Spring travertine deposit and about 2.8 mi west of the Arroyo Colorado travertine deposit on the Marmon Ranch 7.5 minute quadrangle.

### 6. Bobo Butte (sec. 5 T6N R2W, Valencia Co.)

Travertine deposits occur in the vicinity of Carrizozo Arroyo and Bobo Butte (Kelley et al., 1976). Those at Bobo Butte are larger but consist of "travertine-cemented pediment gravels" (Zilinski and Callender, 1976). A syncline runs through Bobo Butte, which is capped by Santa Fe group sedimentary rocks. The flat cap is probably a remnant of the Ortiz pediment (Zilinski and Callender, 1976). Minor travertine and tufa occur about 0.8 mi west of Bobo Butte in Carrizo Arroyo. These deposits are on the South Garcia SE 7.5 minute quadrangle.

### 7. Cañon del Torreon (SW1/4 sec. 11 T6N R5E, Torrance Co.)

A travertine deposit that was "too small to map" was reported by Reiche (1949, p. 1,200) on the Bosque Peak 7.5 minute quadrangle.

### 8. Cedar Hills (SE1/4 sec. 23 and SE1/4 sec. 26 T21S R2W, Doña Ana Co.)

Four inactive travertine quarries were mapped by Clemons (1976) along the east side of the Cedar Hills fault zone on the Corralitos Ranch 7.5 minute quadrangle. The travertine is banded and its color varies between pink, orange, lavender, white, brown, and gold (McLemore and Sutphin, 1996). These quarries probably were mined briefly by the Apache Springs Company as the Rainbow mine in the 1970s, although they have been frequently reported as active by mining interests in the 1980s and 1990s.

### 9. Cliffroy Mine (SW1/4 sec. 33 T19S R19W, Grant Co.)

At the Cliffroy mine, psilomelane in the Gila Conglomerate grades upward into banded travertine near the surface (Gillerman, 1964, p. 168). The Cliffroy mine is in the Redrock manganese area on the southeast side of Caprock Mountain and on the Caprock Mountain 7.5 minute quadrangle.

### 10. Cloudcroft (N1/2 sec. 3 T16S R12E, Otero Co.)

Travertine is present at the foot of the Snow Canyon Ski Area just east of Cloudcroft. Improvements at the ski facility have obscured geological relationships but the travertine appears to be active and related to springs or wells near U.S. Highway 82. The deposit is on the Cloudcroft 7.5 minute quadrangle.

### 11. Cottonwood Creek (T16S R24-25E, Eddy Co.)

Large deposits of late Pleistocene travertine are present along Cottonwood Creek. The travertine is very porous

and spongelike and rests on alluvium along the banks of the creek. Mammiform crusts line some sides of the travertine masses, which are 6-8 ft in largest dimension (Fiedler and Nye, 1933, pp. 29-30). These deposits are on the Hope NE and Espuela 7.5 minute quadrangles.

**12. Coyote Springs (NW<sup>0</sup>/4 sec. 24 T9N R4E, Bernalillo Co.)**

A small outcrop of travertine occurs near Coyote Spring (a.k.a. Arroyo or Soda Spring) south of the Tijeras fault on the Kirtland Military Reservation (Reiche, 1949). Coyote Springs, in Arroyo del Coyote about 0.5 mi west of the military reservation boundary with the national forest, emits CO<sub>2</sub>. The travertine in the arroyo contains clasts that are predominantly granite, quartzite, and schist, all of Precambrian age (Grant, 1982). The deposit forms a terrace along the Tijeras fault zone (Reiche, 1949) and it is on the Mount Washington 7.5 minute quadrangle.

The Hubbell bench and its southward extension, the Joyita bench, are prominent features west of the Manzano Mountains in eastern Valencia County. The western edge of the Hubbell-Joyita bench is bounded by the Hubbell Springs-West Joyita fault system (Kelley, 1977). The northernmost portion of the Hubbell bench has large travertine occurrences that are about 5 mi north of the Valencia-Bernalillo County line. Similar geology occurs to the south in Valencia County.

**13. Dark Canyon (SE<sup>0</sup>/4 sec. 20 T12S R13E, Otero Co.)**

The Dark Canyon travertine (Hahman and Colpitts, 1991) is at the confluence of Dark, Pete Gaines, and Cherokee Bill Canyons (Ruidoso 7.5 minute quadrangle) in Otero County. The banded-travertine-cement portions of the rubble are exposed in a prominent roadcut. Karst is well developed here and the deposit is essentially in a sinkhole. Karst processes are probably still actively producing collapse breccias locally (Colpitts and others, 1991). The roadcut consists of San Andres Formation limestone and dolomite with quartz sandstone interbeds overprinted by karst collapse and travertine and by flowstone deposition.

**14. Derry Warm Springs (sec. 29 T17S R4W, Sierra Co.)**

The Derry Warm Springs travertine deposits are small. The spring issues from a limestone bluff at a temperature of 93.2°F (Summers, 1965, 1976). The spring is on the east side of the Rio Grande valley about 1 mi north of Derry. These deposits are on the Garfield 7.5 minute quadrangle.

**15. East Potrillo Mountains (SE<sup>0</sup> sec. 25 T28N R2W, Doña Ana Co.)**

This deposit is described briefly in McLemore and Sutphin (1996). It has been called a "marble quarry in marbleized limestone" (Seager and Mack, 1994) along the Robledo fault, but may be a fissure-ridge travertine (McLemore and Sutphin, 1996). The stone is coarsely crystalline and white with black bands. This deposit is on the Mount Riley 7.5 minute quadrangle.

**16. Eddleman Springs (sec. 31 T7N R5W, Cibola Co.)**

The Eddleman Spring travertine deposit is small and is related to an active spring. It is about 3 mi southeast of the Badger Windmill deposit and about 3 mi southwest of the Arroyo Colorado deposit on the Marmon Ranch 7.5 minute quadrangle (Maxwell, 1988).

**17. Faywood Hot Springs (sec. 20 T2OS R11W, Grant Co.)**

Faywood Hot Springs is near City of Rocks State Park on the Faywood 7.5 minute quadrangle. The spring is within 1 mi of the Blue Mountain fault and the Faywood

rhyolite dome (Elston, 1957, pp. 76-77). Size estimates vary, probably because of adjacent construction, but at one time the deposit was about 600 ft in diameter and 30 ft high with a spring in a 20 ft crater-like opening on the top (Bartlett, 1856 *in* Summers, 1976), although it is smaller today. This deposit is discussed extensively by Summers (1976).

**18. Goat Ridge (sec. 4 T22S R9W, Luna Co.)**

The Goat Ridge travertine was mentioned by Darton (1916, p. 109 *in* Griswold, 1961, p. 146). He placed it as "3 miles northwest of Mirage" but it is actually on the southeast slope of Goat Ridge on the Goat Ridge 7.5 minute quadrangle. The travertine, which Darton called onyx, is in fissures in agglomerate. It is nearly white with uneven texture, but the deposit is small.

**19. Hogsback Lode (sec. 31 T22S R15W, Grant Co.)**

Travertine about 3 ft thick is present along the fault in a small prospect pit at the Hogsback lode (Hedlund, 1978) on the Ninety-six Ranch 7.5 minute quadrangle.

**20. Jemez Hot Springs (sec. 23 T18N R2E, Sandoval Co.)**

The Jemez Hot Spring travertine or tufa deposit, sometimes referred to as "Upper Jemez Springs," is in San Diego Canyon about 2 mi south of the Soda Dam deposit (Summers, 1976). Numerous springs are active and have been developed extensively as an internationally known resort with mineralized water temperatures ranging from 94 to 168°F (Summers, 1976, 1965). Tufa and travertine mounds are widespread including those forming at man-made discharge points. Summers (1976) discusses these deposits in detail and includes references to extensive literature. The deposit is on the Jemez Springs 7.5 minute quadrangle.

**21. Las Huertas (sec. 28 T11-12N R4-5E, Sandoval Co.)**

The Las Huertas deposit consists of travertine and calcareous tufa precipitated along Las Huertas Creek near the Las Huertas picnic area (Kelley, 1977, fig. 45) on the east flank of the Sandia Mountains. The carbonate occurs as thin rimstone dams, coatings on the bottom of pools and commonly as a coating on vegetation and rocks in the streambed. Many of the pools are man-made behind sawn logs. Carbonate deposition is rapid and has covered recent debris and rock fragments in the dams. The carbonate also occurs as bumpy nodular or mammillary masses and as coatings on vegetation that later decays leaving carbonate tubes behind. Some carbonate occurs as small cascade travertines at the very small waterfalls in the creek. Algae are abundant in the pools. The deposit is on the Sandia Crest 7.5 minute quadrangle.

**22. Lucero Mesa (T7N R2W, Valencia Co.)**

The Lucero uplift is one of the major structures comprising the southeastern margin of the San Juan Basin of northwest New Mexico. The uplift is represented in Valencia County mainly by the Sierra Lucero (to the south) and Lucero Mesa (to the north). North of Lucero Mesa, the uplift includes Suwanee Peak described below. Several travertine occurrences are described briefly by Titus (1963). These deposits are largely on the South Garcia and surrounding 7.5 minute quadrangle.

The main part of the Lucero uplift in Valencia County contains abundant travertine deposits of Plio-Pleistocene age (Wright, 1946). Minor travertine deposition presently is occurring west of Mesa Aparejo (Austin and Barker, 1990; Fisher, 1979; Kelley, 1977). Some springs were active during late Santa Fe time because this unit contains travertine pebbles (Wright, 1946).

Travertine deposits are widespread in a narrow, sporadic band three miles wide along the Lucero uplift from near South Garcia to beyond the Socorro County line. The travertine deposits are up to 178 ft in thickness. The source of the carbonate in the travertine appears to be at least 2,100 ft deep and is probably the San Andres limestone and other nearby carbonates (Kottlowski, 1962). Numerous occurrences of travertine are mapped on the west slope of Lucero Mesa. Some of the larger occurrences have active deposition; most deposits are relatively small.

Ultramarble Inc. (formerly All American Marble Company) mined travertine on the Laguna Indian Reservation in the 1960s. The main quarry was on leased Indian land in unsurveyed sec. 7 T7N R2W, with additional reserves in secs. 6, 18, 19, 30, and 31. Presently this quarry, known as the Ultra quarry (a.k.a. Omission quarry) is not in operation. The deeper travertine at the Ultramarble quarry is much harder and more translucent than that near the surface. Wire-saws were used to produce 10-20 short ton (st) blocks trucked to Albuquerque for slabbing and polishing. Products included interior sheets (1 inch thick), exterior sheets (2 inch thick), and 8 inch slabs. Several buildings in Santa Fe, including the capitol, and Albuquerque contain Ultramarble travertine (Kelley, 1977).

### 23. Malpais (sec. 35 T11N R10W, Cibola Co.)

The Malpais travertine deposit is approximately 1.2 mi southwest of Grants on the Grants 7.5 minute quadrangle. A knob of travertine or tufa is part of a kipuka in the Malpais lava flow (Thaden et al., 1967). The travertine is pale-yellowish-gray, spongy, porous limestone containing casts of reeds and other plants. Thaden et al. (1967) locates the deposit in Valencia County, however with the subsequent creation of a new county, the deposit is now in Cibola County.

### 24. North McKittrick Canyon (SW<sup>1</sup>/<sub>4</sub> NW<sup>1</sup>/<sub>4</sub> sec. 34 T26N R21E, Eddy Co.)

The North McKittrick Canyon deposit is in the canyon called "Devil's Den" on the King (1948) map that is adjacent to North McKittrick. This deposit is representative of the many throughout the Guadalupe Mountains. It is actively precipitating calcite and has an inferred source in the Capitan limestone (Lambert and Harvey, 1987, p. 42). The main deposition is in a small pond (about 10 ft wide and 20 ft long) with abundant algae. Some former deposition areas and ponds are now dry or submerged under more recent ponding. The local geology, isotope studies, and spring system are discussed in Lambert and Harvey (1987). This deposit is on the Guadalupe Peak 7.5 minute quadrangle.

### 25. Mesa Aparejo (secs. 12-13 T5N R3W, Valencia Co.)

Also known as Gray Mesa, the deposits of travertine at Mesa Aparejo were mapped by Kelley and Wood (1946) and are much larger than those on the northern Lucero uplift (Kelley, 1977). They formed along the Comanche fault and are mostly dormant except for very localized small springs. Kelley (1977) estimated a travertine resource of 200 million st. Only a small portion of this resource has been exploited (see New Mexico Travertine under "Commercial travertine in New Mexico" below for a complete discussion). These deposits are on the Mesas Mojinás 7.5 minute quadrangle.

### 26. Mesa del Oro (T6N RSW, Cibola Co.)

The north end of Mesa del Oro is underlain by thick, widespread, porous travertine deposits. The yellow-buff to white travertine (weathers buff to orange) is overlain

by basalt and is believed to be a spring deposit of late Tertiary or Pleistocene age although the source is not known. These deposits have been drilled as a travertine/high calcium limestone resource (unpublished data and cores in NMBMMR archives). The travertine is very extensive and underlie about 10 mil (Jicha, 1956, 1958) with reserves estimated to be about 1.6 billion st (700,000,000 yd<sup>3</sup>, written comm., Intrasearch Corp, 1981). The deposit is thickest on the north and east and rapidly thins to the west, less so to the south.

The Mesa del Oro travertine is underlain by Chinle shale and thus small-to-very-large travertine landslide blocks encircle the travertine still in place (Fig. 3). This deposit, which is discussed extensively by Jicha (1956, 1958), is on the Cerro del Oro, Cerro Verde, and Chicken Mountain 7.5 minute quadrangles. Nearby travertine deposits include those at Salado Spring and Pato Mesa.

### 27. Montezuma Salient (S1/2 sec. 11 T13N R5E, Sandoval Co.)

A small travertine deposit occurs in the Sandia uplift at the base of the Montezuma Salient. This deposit is 20 ft thick, 1,000 ft wide, 2,000 ft long, and occurs within Santa Fe gravels on the Placitas 7.5 minute quadrangle. The source spring for the travertine was probably related to the San Francisco fault (Kelley, 1977).

### 28. Ojo Caliente Zuni (sec. 20 T8N R20W, Cibola Co.)

Springs in the Ojo Caliente area have precipitated travertine, tufa, or calcareous sinter (Anderson, 1987). The deposits near the town of Ojo Caliente are moderate in size and tend to cap small ridges and occur on the Ojo Caliente 7.5 minute quadrangle. One very tiny remnant is present about 8 mi east-northeast in sec. 9 T8N R19W on the Plumasano Basin 7.5 minute quadrangle.

### 29. Ojo del Gallo (secs. 2-3 10-12 T10N R10W, Cibola Co.)

The Ojo del Gallo tufa and travertine is approximately 3.5 mi south of Grants near San Rafael in Cibola County. The travertine was deposited by a spring issuing from a fault cutting the Permian San Andres Limestone whose water eventually flows into the Rio San Jose. The travertine is nearly 100% carbonate and was deposited inorganically by the rapid outgassing of CO<sub>2</sub> at a cascade below the spring. Older, extensive spring deposits are upgradient of the current spring, but most are relatively friable tufa (White, 1989). This deposit is on the San Rafael 7.5 minute quadrangle.



FIGURE 3—Travertine blocks surround travertine-capped Mesa del Oro in Cibola County, New Mexico. Walls of the ruin in left foreground are constructed of travertine blocks.

**30. Owl Cliff (secs. 25-26,35-36 T25N R8E, Rio Arriba Co.)**

Calcareous tufa of hot-spring origin is present at Owl Cliffs and reaches a thickness of about 200 ft (Bingler, 1968, p. 137). The deposit is in two parts separated by the Rio Ojo Caliente and associated with Statue Spring to the west. It covers a total of about 0.5 mi<sup>2</sup>. The tufa is gray to brown and caps the Tertiary Santa Fe Group sediments. It is internally complex and forms a tiered constructional bench (Bingler, 1968). This deposit is on the La Madera and Ojo Caliente 7.5 minute quadrangles.

**31. Palm Park (SE<sup>1</sup>/<sub>4</sub> SW<sup>1</sup>/<sub>4</sub> sec. 24 T18S R3W, Doña Ana Co.)**

The Palm Park travertine deposits are described in detail by Fitzmaurice (1990). Limestone and travertine, darkyellow-brown to light-brown-gray to white, locally moderate pink, sucrosic texture to dense and hard, in beds 1-4 ft thick, locally contains algal filaments and gastropod remains. The unit represents the upper deposits of travertine mounds.

The white travertine weathers a grayish-orange. It consists of very porous, vuggy, banded calcite with siliceous laminae and intraclastic debris, and contains numerous palm(?) frond impressions, twigs, and tubular casts and molds. Massive beds are up to 6 ft thick. The lenticular units pinch out along strike. These deposits are on the Hatch 7.5 minute quadrangle.

**32. Pato Mesa (secs. 19-20 T5N R5W, Cibola Co.)**

The Pato Mesa "travertine" deposit is about 10 mi southeast of the Mesa del Oro deposits. It probably formed about the same time as the Mesa del Oro deposits and is described by Jicha (1956, 1958). This carbonate deposit ranges from 0 to 25 ft in thickness and rests on basalt. Pato Mesa is almost surrounded by landslide debris that locally contains "travertine". The author Barker visited Pato Mesa and did not find clear-cut travertine, but caliche is abundant. This deposit is on the Chicken Mountain 7.5 minute quadrangle.

**33. Peloncillo Mountains (secs. 18 and 29 T26S R20W, sec. 12 T26S R21W, Hidalgo Co.)**

A white evaporite, called an alkali impregnated deposit, was described by Drewes and Thorman (1980). The rocks are probably largely carbonate and were deposited from seeps on the Cotton City 7.5 minute quadrangle.

**34. Puertecito (secs. 30-31 T3N R4W, sec. 25 T3N R5W, Socorro Co.)**

The Puertecito deposit unconformably overlies Triassic redbeds and consists of conglomerate cemented by travertine. The entire unit is about 50 ft thick with prominent botryoidal and colloform structures. These travertine deposits are along the Lucero uplift and are on the Puertecito 7.5 minute quadrangle.

**35. Riley North (T2-3N R3W, Socorro Co.)**

The Riley travertine is in two locations. The first and larger deposit, North Mesa (Barker, 1983; Bolton, 1993), underlies about 17 mi<sup>2</sup> and is about 5 mi northeast of the town of Riley. This deposit ranges in thickness from about 5 to 85 ft and some portions are suitable for quarrying (Figs. 4, 5). The Riley sections are massive and nearly white. Owing to its size and varied morphology and lack of outcrop, the Riley travertine has been variously described as a playa, lake, caliche, or travertine deposit. A well-developed caliche overprint suggests an age of at least 1 million years. This deposit is on the Riley and Ladron Peak 7.5 minute quadrangles.



FIGURE 4—Laminar, vuggy, well-indurated, near-white travertine at the south end of the North Riley deposit; R. M. Chamberlin for scale (photo courtesy of M. J. Logsdan).

**30. Riley South (T1N-1S R2-3W, Socorro Co.)**

The South Riley deposit underlies about 9 mi<sup>2</sup> and is about 10 mi southeast of Riley (Barker, 1983). This deposit is similar in origin to the Riley North deposit and they may have been connected at one time (Barker, 1983). The Riley south deposit is more clastic and generally less indurated than Riley North. It is on the Silver Creek and Carbon Springs 7.5 minute quadrangle.

**31. Rio Peñasco (T165 R16-17E, T17S R18E, Chaves Co.)**

Extensive accumulations of travertine occur along the Rio Peñasco and include natural dams that formerly impounded stream waters. Travertine clasts produced by headward erosion are common in the stream channel (Renick, 1926, pp. 121, 123). This deposit is on the Elk, Thimble Canyon, and Dunken 7.5 minute quadrangles.

**32. Rocky Arroyo (T21S R25E, Eddy County)**

Large amounts of travertine occur along Rocky Arroyo (Fiedler and Nye, 1933, p. 30) on the Azotea Peak 7.5 minute quadrangle.

**33. Salado Spring (sec. 5 T5N R6W, Cibola Co.)**

The Salado Spring deposit is west of Mesa del Oro and is about 8 mi from the travertine there. It consists of small, irregular lens of yellow-buff to white, banded porous travertine and spring-deposited gypsum (Jicha, 1958) and is on the Cerro del Oro 7.5 minute quadrangle.



FIGURE 5—Detail of laminated vuggy travertine at the North Riley travertine occurrence shown in Figure 4.



**40. Salt Springs Wash (secs. 4-5,8-9 T21N R16W, San Juan Co.)**

The Salt Springs Wash deposit is described as a "limestone dike" by O'Sullivan et al. (1989). The gray limestone was compared by them to travertines collected in Arizona. Similarities led them to conclude that the limestone dike had a hot water origin and "probably represents an ancient conduit that transferred calcium carbonate upward. Surficial travertine was removed by erosion. This deposit is on the Grey Hill Spring 7.5 minute quadrangle.

**41. San Diego Mountain (sec. 31 T19S R1W, Doña Ana Co.)**

Small, partly radioactive travertine deposits occur at the northwestern base of San Diego Mountain (Boyd and Wolf, 1953) and have been mapped by Seager (1975) and Seager et al., (1971). A later U.S. Geological Survey update of a topographic map identifies the mountain as Tonuco Mountain. The travertine is of late Pleistocene to Holocene age and is on the Selden Canyon 7.5 minute quadrangle.

**42. San Ysidro (T15-17N R1-3E, Sandoval Co.)**

The San Ysidro travertine deposits consist of light-tan, thin- to thick-bedded travertine ranging from 0 to 50 ft thick in several large pods and many small ones on the southwestern and southeastern margins of the Nacimiento uplift. Harrington (1948) reports travertine mounds up to 400 ft thick in the area. These exposures are mostly along the west side of the Pajarito fault, near NM-44 and NM-4, north and west of San Ysidro, mainly on Zia Pueblo land (Woodward and Martinez, 1974; Woodward and Reutschilling, 1976; Woodward et al. 1977). These deposits are on the San Ysidro, Gilman, and Holy Ghost Spring 7.5 minute quadrangles.

Precambrian lithologies are included in the travertine as pebbles and cobbles giving an overall conglomeratic appearance to this deposit. The travertine is locally gradational with either overlying or underlying terrace or pediment gravel (Woodward, 1987).

Much of this travertine suitable for building stone (Woodward, 1987) is within 0.5 mi of NM-44. These deposits include those known as Phillips Spring, Indian Spring (Summers, 1976, pp. 15-16), San Ysidro Spring, and the crater springs of the Rio Salado (Harrington, 1948).

**43. Selden Hills (SE<sup>1</sup>/4 sec. 20 T20S R1W, Doña Ana Co.)**

Travertine was quarried in the Buckle Bar area of the Selden Hills. It is white, but the deposits are small (McLemore and Sutphin, 1996). They are on the Selden Canyon 7.5 minute quadrangle.

**44. Sitting Bull Falls (sec. 3 T24S R22E, Eddy Co.)**

Sitting Bull Falls (Fig. 6) is a well-known tourist attraction and state park characterized by active deposition of a waterfall or curtain travertine (Chafetz and Folk, 1984). The deposit includes older inactive portions, a large cave, and abundant moss (Adams, Love, and Hawley, 1993). The source for the carbonate-charged waters is via Sitting Bull Spring fed apparently by waters from the nearby limestone section. The travertine is on the Queen 7.5 minute quadrangle.

**45. Soda Dam (sec. 14 T18N R2E, Sandoval Co.)**

The Soda Dam travertine is an active fissure ridge deposit (Chafetz and Folk, 1984) that crosses NM-4 about 1 mi northeast of the town of Jemez Springs. This deposit is one of the most recent portions of a much larger sys-

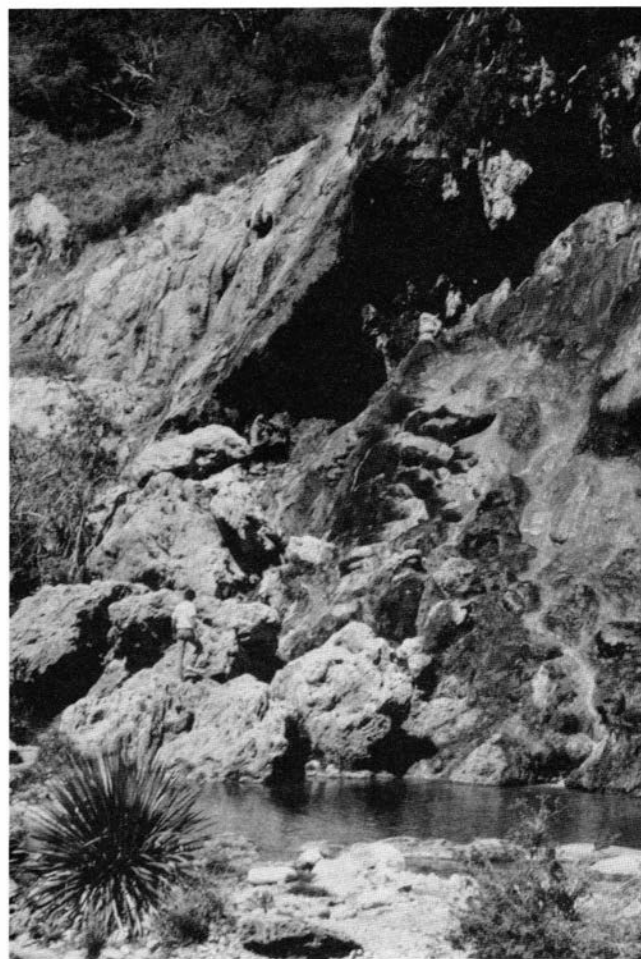

FIGURE 6—Waterfall or curtain travertine exposed as Sitting Bull Falls in Eddy County, New Mexico. A man standing at lower left provides scale.

tem, parts of which are much higher than Soda Dam. About 20 springs and seeps are present near Soda Dam, which is along the Jemez fault zone that juxtaposes limestone and gneiss-granite. Goff and Shevenell (1987) discuss the Soda Dam geology and previous work. Summers (1965, 1976) discusses hydrology and water chemistry along with previous work. These deposits are on the Jemez Springs 7.5 minute quadrangle.

**46. Suwanee Peak (NW<sup>1</sup>/4 sec. 2 T8N R3W [unsurveyed], Valencia Co.)**

The Suwanee Peak deposit is just northeast of Suwanee Siding (AT&SF RR) along NM-6 in the northwesternmost corner of Valencia County. It is Hill 5995 (Correo VABM) on the South Garcia 15 minute topographic quadrangle. Suwanee Spring is at the base of this hill and is on the Laguna Indian Reservation. The deposit is a small knob that caps Suwanee Peak (Kelley et al., 1976), which consists of Entrada Sandstone at its base overlain in ascending order by the Morrison Formation, Dakota Sandstone, and Mancos Shale.

**47. Tortugas Mountain (sec. 23 T23S R2E, Doña Ana Co.)**

Travertine-cemented conglomerate deposited by a hot spring occurs within undifferentiated fan deposits of the Camp Rice Formation on the northwest tip of Tortugas Mountain (King and Kelley, 1980). It occurs on the Tortugas Mountain 7.5 minute quadrangle.



#### 48. Travertine Hills (secs. 27-28 and 33 T9N R4E, Bernalillo Co.)

Travertine occurs on the east side of the Albuquerque basin within the Kirtland military reservation (Grant, 1982, p. 326). These low hills were noted by Reiche (1949) who described them as Tertiary gravels. Grant (1982) describes them as north-south aligned mounds of travertine covering about 240 acres and that rise about 100-125 ft above the mesa floor. They lie approximately along the Hubbel Spring fault trace, projected from its prominent bench on the Isleta Indian Reservation. The travertine is conglomeratic and consists of local rock types—predominantly Paleozoic limestone, sandstone, and shale. Clasts range from sand to boulders as large as 12 inches in diameter (Grant, 1982). This deposit is essentially calcite-cemented gravel that may be related to spring deposition. It is on the Hubbell Spring 7.5 minute quadrangle.

#### 49. Tres Hermanas (sec. 24 T28S R9W, Luna Co.)

The Tres Hermanas (Linberg) travertine deposit, called Mexican onyx by Griswold (1961, pp. 145-146), occurs along the southeast slopes of the Tres Hermanas Mountains on the Columbus 7.5 minute quadrangle. Access is by travelling 4 mi west-northwest on a road that passes the Columbus cemetery on the way to the Linberg Claims. The travertine is in thick, often mammillary, north-trending veins in a latite sequence. It occurs as a Mexican-onyx breccia (early) cemented by massive white to colorless calcite (later). The fragments consist of banded cream- to honey-yellow "onyx" that yields blocks up to 5 ft in diameter.

#### 50. Truchas (sec. 27 T21N R10E [unsurveyed] and sec. 35 T21N R10E, Rio Arriba County)

The two travertine deposits are filled fissure veins cutting Precambrian Sangre de Cristo Formation. In both cases the nearly vertical banded travertine is pale yellow-to-light brown, 1-5 ft wide, and exposed for 300-500 ft along strike. The deposit in sec. 27 in on the Truchas Land Grant 2 mi northeast of Cordova, New Mexico. The deposit in sec. 35 in on U.S. Forest Service land and may extend southward into secs. 1-2 T20N R10W of Santa Fe County.

#### 51. Truth or Consequences (T13S R4W, Sierra Co.)

Several thermal springs occur within the town of Truth or Consequences, New Mexico, on the Elephant Butte and Cuchillo 7.5 minute quadrangles. Quaternary spring activity in the area is shown by the manganese and travertine deposits, solution openings, and altered rock that extends at least 0.5 mi northwest of town (Summers, 1976).

#### 52. Victorio (secs. 28, 29, 32, and 33 T24S R12W, Luna Co.)

"Mexican onyx occurs sparingly in the lead-silver veins of the Victorio mining district south of Gage. Although the onyx is of excellent quality, it occurs only in thin veins" (Griswold, 1961, p. 146). This district is also known as Gage, Middle Hills, or Mine Hill (File and Northrup, 1966, p. 22) and is on the Gage 7.5 minute quadrangle.

#### 53. Zuni Salt Lake (sec. 31 T13N R18W [unsurveyed], Catron Co.)

Small tufa deposits on the south edge of Zuni Salt Lake and on the Zuni Salt Lake 7.5 minute quadrangle. They are mainly at the base of the two hills along the shoreline. An additional occurrence is along the northeastern shoreline. The tufa consists of calcareous pods and layers. It is locally reticulate or composed of coalesced tubes and was probably deposited around plants or plant fragments (Cummings, 1968).

### Commercial travertine in New Mexico

#### New Mexico Travertine (secs. 12 and 13 T5N R3W)

NMT is one of three dimension-stone operations producing travertine in the United States; the other two are in Idaho and Montana. NMT quarries about 400 st of stone per month from extensive, well-bedded, laminar lenses of travertine (Fig. 2) just east of Mesa Lucero in the eastern foothills of Mesa Aparejo. The quarries are about 25 mi west of Belen in secs. 12 and 13 T5N R3W on U.S. Bureau of Land Management and private lands.

**General geology of Mesa Aparejo—Limestone** of the Pennsylvanian Madera Formation (P<sub>m</sub>) in the subsurface to the west is probably the primary source rock for the calcium-rich, CO<sub>2</sub>-charged water that formed the Quaternary travertine (Qt) at the edge of Mesa Aparejo. The lower 800 ft of the Madera Formation are well exposed just west of the NMT travertine quarries (Kelley and Wood, 1946; Titus, 1963; Cooper, 1964) and probably represent the Gray Mesa Member of the Madera (Kelley and Wood, 1946; Kues et al., 1982). Other bedrock units nearby include Pennsylvanian Sandia Formation (Ps), Permian Abo (Pa) and Yeso (Py) Formations, and Precambrian granite and schist (p-C). Kelley and Wood (1946), summarized by Titus (1963), showed the structural and stratigraphic relationships (Fig. 7) of Mesa Aparejo (Gray Mesa). Hammond (1987) summarized regional stratigraphy and structure south of Mesa Aparejo; Slack and Campbell (1976) summarized structure to the north. Cooper (1964) was concerned primarily with the travertine.

The large northeast-trending Comanche fault mostly west of the travertine (Fig. 8) was mapped as a normal fault dipping 70° east by Cooper (1964). Previously Kelley and Wood (1946) had identified this structure as the "Comanche thrust fault" that dips shallowly to steeply westward. Part of the difficulty in the identification of the fault type was that the dip varies considerably in the vicinity of Mesa Aparejo. Cooper's interpretation appears correct because it is based on drill-hole-data and observation of the fault plane in outcrop at the travertine quarries and is consistent with the downdropped Paleozoic section just east of the fault. With respect to rocks to the west, the Madera and other bedrock units east of Mesa Aparejo have dropped several thousand feet into the Albuquerque-Belen Basin portion of the Rio Grande rift. Sandstone, conglomerate, and mudstone of the Santa Fe Group (Tertiary) now overlie downfaulted older bedrock units and lap onto Mesa Aparejo. The Comanche fault and associated minor faults acted and continue to influence circulation of CO<sub>2</sub>-charged ground water and spring water. At Mesa Aparejo travertine was deposited as extensive, thick, laminar lenses. Just north of the mesa (secs. 35 and 36 T6N R3W), travertine presently being deposited from springs illustrates one way older and larger deposits may have formed (Fig. 9).

The varieties of travertine at Mesa Aparejo are distinguished by color and structure, but the mineralogy and origin are fundamentally the same for each. Bedding is commonly laminated with characteristic serrations probably representing the forward surface of a micro-terraced rimstone dam that impounded a pool of spring water that deposits limestone (Fig. 9). Concretionary masses of various dimensions are largely due to algal activity. Rod-like structures, frequently upright and clustered in tufts or masses, may be in part algal or bacterial when microscopic, but most likely represent deposition around grass, stems, or branches. Holes within travertine may result from rapid accumulation over tufted or dimpled surfaces,

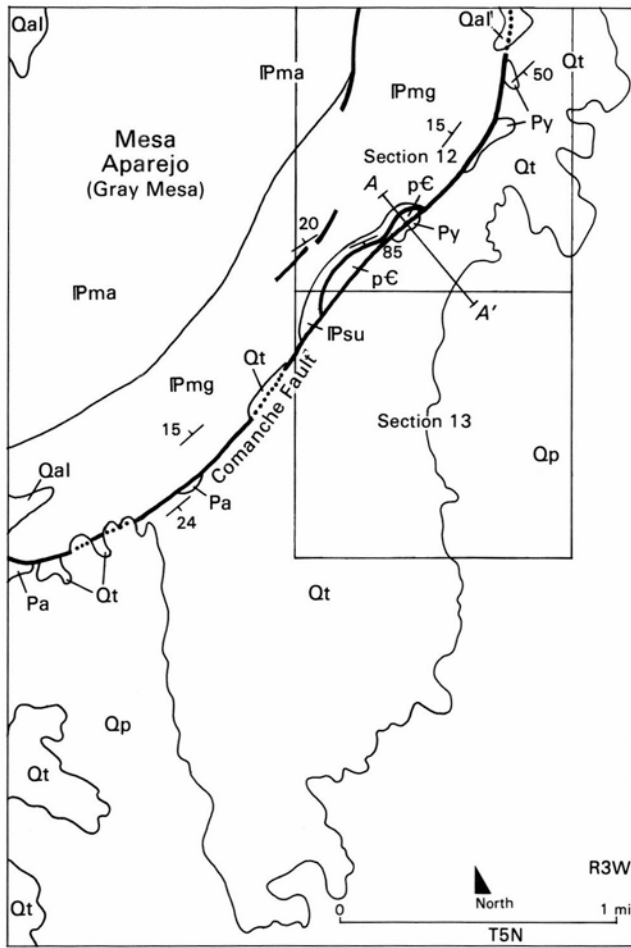

DESCRIPTION OF UNITS

- Qal Alluvium (Quaternary)—valley fill; sandy washes
- Qp Pediment gravel (Quaternary)—several levels with some caliche interbeds
- Qt Travertine (Quaternary)—spring deposits of calcium carbonate; banded, laminated, and fragmental; related to ancient springs along fault
- Py Yeso Formation, upper part of Los Vallos Member (Lower Permian)—tan-brown, friable siltstone, sandstone, and shale with minor gypsum
- Pa Abo Formation (Lower Permian)—red-brown, fine- to coarse-grained sandstone, siltstone, and shale with minor limestone interbeds
- IPma Madera Formation, Atrasado Member (Upper Pennsylvanian)—gray to dark-gray limestone, shale, and conglomeratic sandstone
- IPmg Madera Formation, Gray Mesa Member (Middle Pennsylvanian)—gray to dark-gray, predominantly cherty, thick- to thin-bedded limestone with minor shale and sandstone
- IPsu Sandia Formation, upper clastic member (Middle Pennsylvanian)—gray to black arenaceous limestone, carbonaceous shale, conglomerate, and sandstone
- pC Pink granite and associated green chlorite schist (Precambrian)—highly fractured

FIGURE 7—Geologic map of Mesa Aparejo (after Kelley and Wood, 1946; Titus, 1963; Kues et al., 1982). A–A' approximate line of the diagrammatic cross section in Figure 8.

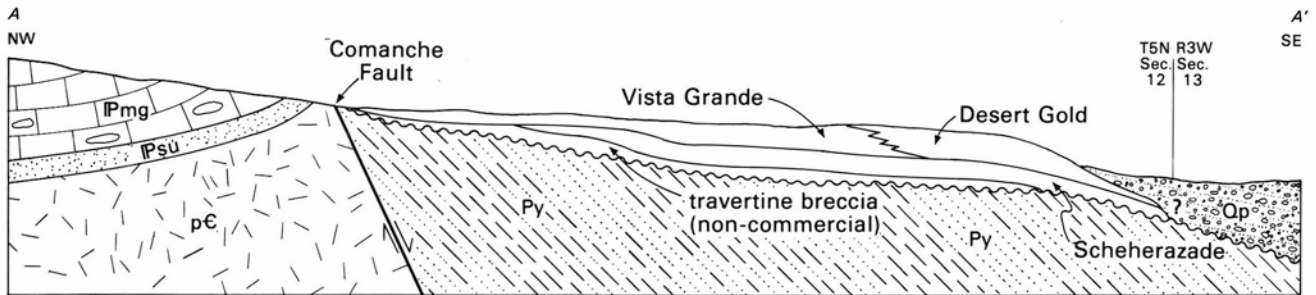

FIGURE 8—Diagrammatic section across the Mesa Aparejo travertine quarried by NMT in secs. 12 and 13 T5N R3W, showing the overlapping east–west relationship of Quaternary travertine with Permian bedrock at a Precambrian inlier. See Figure 7 for stratigraphy. Note the local normal dip of the Comanche fault at the quarry and the lateral changes in travertine varieties (modified from Cooper, 1964; Austin and Barker, 1990).



FIGURE 9—Active formation of travertine near the northern end of Mesa Aparejo (SE¼ sec. 35 T6N R3W). The spring supplying this travertine issues from the Madera Formation (limestone) and is about 0.2 mi upstream to the west. Note hammer handle in lower left for scale. View is to the northwest.

gas bubbles encrusted by travertine, or voids produced by primary deposition of soluble salts later removed by dissolution. Shrub-like forms, composed of upward-radiating bacterial clumps in CaCO<sub>3</sub> (Chafetz and Folk, 1984), are locally abundant.

The highly variable color of the Mesa Aparejo travertine is a result of impurities. Pink and red are probably primary and are due to inclusion in the travertine of red iron oxide from nearby Permian sandstone, siltstone, and shale. Yellow and brown are secondary and were produced close to the surface by percolating oxidizing waters during case hardening and weathering of the travertine.

Onyx is translucent calcium carbonate in which layers parallel the surfaces of infilled voids or laminae, and is intimately associated with travertine. Most onyx, now calcite, was deposited originally as aragonite, a metastable higher-temperature form of calcium carbonate. Local coarse-grained aragonite is associated with spring orifices mainly at the NMT Apache Golden Vein of the quarry in the Gray Mesa Member of the Madera Formation. Because aragonite is more soluble than the calcite, advanced dissolution forms soft crumbly zones and large voids later filled with clay or mud (Cooper, 1964).

**Commercial varieties of NMT travertine**—NMT produces commercial varieties of stone including *Santa Fe Ivory* (white to creamy-white travertine), *Scheherazade* (pale-cream to pink travertine with onyx; Fig. 10), *Desert Creme* (yellow to brown travertine with minor onyx and lilac- or pinkish-gray sections), *Vista Grande* (dark reddish-brown to cream travertine with onyx), *Desert Gold* (yellow-gold with abundant onyx), and *Apache Golden Vein* (altered stylolitic yellow to reddish-gray limestone). Production of several sub-varieties is possible by cutting different directions in relation to bedding of the travertines. A "vein cut" cross cuts bedding; a "fleuri cut" parallels bedding. In the past Temple Creme, a white vuggy travertine, was NMT's premier light-colored commercial stone.

Testwell Craig Laboratories classified Temple Creme as travertine marble according to ASTM C-119 (Szypula, 1988). By varieties, the order of 1995 sales is (1) Scheherazade (vein cut only; fleuri cut in the past), (2)

Vista Grande (fleuri cut only), (3) Desert Gold (both vein and fleuri cut; slabs only), (4) Apache Golden Vein (vein cut in slabs only), and (5) Desert Creme (produced as split-face only). Santa Fe Ivory, similar to Nivona from Italy (white, vuggy) and which replaced Temple Creme about 1990 (both vein and fleuri cut), actually is exceeding Scheherazade in sales during late summer in 1995.

Some segments of the architectural market favor light-colored travertine with a relatively even, muted texture. Variegated and brightly colored travertine often is considered less flexible as preferred color combinations change over time. Other architects prefer the more vivid colors and textures, particularly for interiors of large buildings.

Dimension stone consists of blocks, slabs, or sheets of stone cut and finished to specific dimensions for structural, ornamental, or monumental uses. Dimension stone is produced by cutting, fabricating, or selecting stone for specific shapes or sizes. It has become popular in rubble walls, fireplaces, patio floors, and as flagstones, especially where decorative accents and special architectural effects are desired (Austin et al., 1990; Barker and Austin, 1994).

The six varieties of travertine mined by NMT vary in detail within a given layer but are laterally consistent for hundreds of feet. Several additional varieties of travertine have been identified in the Mesa Aparejo area but have not been quarried. Such a wide variety of types within one travertine deposit is very unusual. Cooper (1964) conservatively estimated that the NMT quarries contained reserves of about 45 million ft<sup>3</sup> of associated types of commercial-quality travertine and altered limestone (Table 2). Travertine of all types underlies about 1,140 acres and may total about 200 million st in place (Barker, 1988).

**Quarrying procedures at NMT**—Blocks of travertine are cut with a wire saw, belt saw, or both (Table 3). A Vermeer concrete saw is used to remove caprock overlying the travertine. Large slabs of rocks are prepared by a rail-mounted belt saw that cuts up to 10 ft deep (Fig. 10). This work is done by the belt saw because of the great precision and high output. Until recently, most cutting of travertine blocks was done by the wire saw. During wire-saw cutting, intersecting vertical and horizontal drill

TABLE 2—NMT reserves by variety (Cooper, 1964; NMT, oral comm. 1990, 1995).

NMT variety	Composition and texture	Reserves (million ft <sup>3</sup> )	Remarks
Santa Fe Ivory	travertine	1.5	production on standby
Temple Creme	travertine	7.7	production on standby;
			replaced by Santa Fe Ivory
Scheherazade	travertine/onyx	8.0	most abundant type;
			variable soundness
Vista Grande	travertine/onyx	7.7	case-hardened
			Scheherazade
Desert Gold	travertine/onyx	1.5	onyx abundant; strong
Desert Creme	travertine/onyx	4.2	disseminated black
			limestone clasts
Other varieties	travertine/onyx	14.7	includes "Saladin Onyx,"
			"Mescalero Onyx," and
			"Sioux Breccia"
		Subtotal: ~45 million ft <sup>3</sup>	
Apache Golden Vein	altered Madera limestone	5.0	Apache Golden Vein may be more widespread off NMT property; it is not travertine
		TOTAL: ~50 million ft <sup>3</sup>	

TABLE 3—Saws used at the NMT quarry and mill west of Belen, New Mexico. (NMT, oral comm. 1990, 1995)

Saw	Cut dimensions	Cutting method	Abrasive	Remarks
<u>Mine</u>				
Wire saw	25' deep x 40' long cable pull	$\frac{3}{16}$ " cable drawn through connected drill holes	industrial diamond	$\frac{3}{8}$ " x $\frac{3}{8}$ " diamond segment every 1 $\frac{1}{2}$ " separated by spring spacers
Belt saw	10' deep x 50' long (rail in 10' increments)	1 $\frac{1}{2}$ " belt on movable arm	industrial diamond	automated advance and shutdown (water loss or excess amps drawn); waterjets around perimeter of arm used to remove caprock waste
Concrete saw	34" deep x unlimited length (tracked vehicle)	7' diameter wheel	tungsten carbide tips	
<u>Mill</u>				
Gang saw	variable	as many as 75 reciprocating blades	industrial diamond	spacing of blades is variable
Bridge saw	variable	rotating blade diamond	industrial cut special shapes	accurate to 0.0004"; can
Large block saw	variable, generally $\frac{7}{8}$ inch thick billet	30 vertical, 1 horizontal circular blades	industrial diamond	makes tile billets ( $\frac{3}{4}$ inch available)
Small block saw	variable, generally $\frac{3}{8}$ inch thick billet	12 vertical, 1 horizontal circular blades	industrial diamond	makes tile billets ( $\frac{3}{4}$ inch available)



FIGURE 10—New Mexico Travertine quarry west of Belen, New Mexico, in Scheherazade travertine (trade name). Diamond-impregnated belt saw is cutting 1 $\frac{1}{2}$  inch channel up to 10 ft deep. Wire saw at upper right is "pulling floor" on a block previously cut by the belt saw.

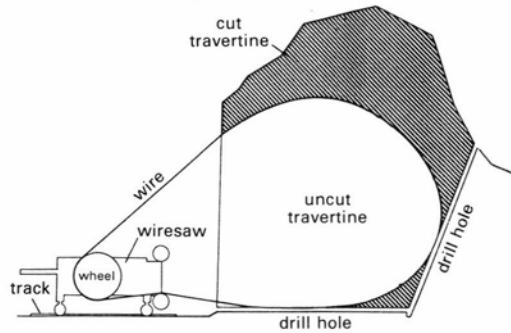

FIGURE 11—Diagrammatic representation of wire-saw operation during a vertical cut through connected drill holes (source: Benetti Macchine, Italy). Tension is maintained by moving saw on tracks. Diamond-impregnated cable is pulled against stone in a continuous loop. Cuts can also be horizontal (common) or any other angle.

holes produce a path through which a wire impregnated with industrial diamonds is drawn. The wire is connected into a continuous moving loop and pulled under tension as it cuts through the travertine toward a wheel on tracks (Fig. 11). The wire saw moves back on the track as the cut is made, then is moved forward and the wire is shortened; this process is repeated as often as necessary to complete the cut (Fig. 12). The cut may be any orientation from horizontal to vertical.

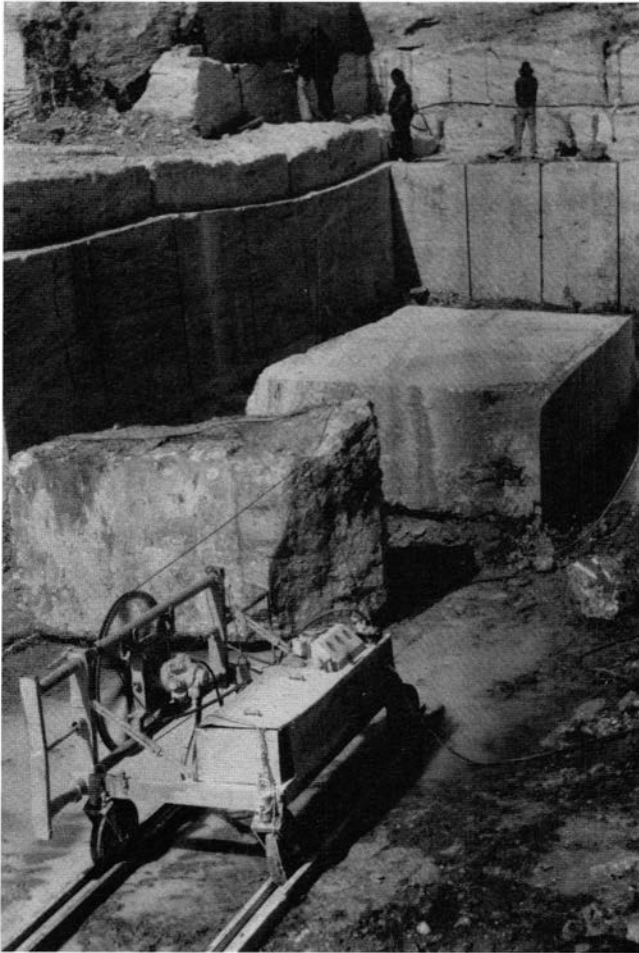

FIGURE 12—Wire saw, with diamond-impregnated cable, in operation at NMT quarries. The cable loops from the motor through a vertical drill hole behind the right face, through an intersecting horizontal drill hole near the base of the face, and back to the motor.

After being broken or cut loose with the wire saw, 150- 300 st slabs are tipped over on their sides using hydraulic wedges. The slabs fall away from the working face and onto loose debris to lessen breakage (Fig. 13). They are split or sawed into 15-20 st blocks, graded, processed on site or loaded onto flat-bed trucks by large front-end loaders or forklifts, and hauled to the dressing plant. Low-grade blocks and waste from the quarrying procedure are crushed on site by several methods. This material is marketed as palletized rubble (larger-sized) or as crushed stone (smaller-sized).

**Milling, dressing, and finishing procedures—**The NMT finishing plant is about 2 mi west of Belen off Exit 191 of Interstate 25 (Fig. 2). The Belen plant can produce 1,000-3,000 ft<sup>2</sup> of travertine slabs per day, but the variable amount of custom work commonly lowers output. Graded and stockpiled quarry blocks are trimmed square using a small wire saw similar to the process at the quarry. Most blocks at the plant are cut into slabs in an adjustable Gaspari gang saw that has as many as 75 diamond-impregnated blades individually adjustable for width of cut (Table 3, Fig. 14). The gang saw usually is set to typically produce 4 x 8 ft, 3/4 inch thick slabs that are then moved to an automatic Gregori polishing line.

The Gregori polishing line removes small ridges produced by the gang saw, yielding a smooth, highly polished, flat surface (Fig. 15). The stone is flushed with water, during cutting and polishing, which removes clay and mud in the voids. Before final polishing, a waterproof, appropriately colored grout is applied, if needed, to the slab surface, filling the voids and partially cementing the stone. Some slabs are backed with fiberglass textile and epoxy to further strengthen them. Epoxy grout has a shiny surface in polished travertine slabs. Cement grout-filled voids appear dull compared to the flat portions of the stone, but colors of either fill are chosen to blend well with the highly polished surfaces.

Complex angle and other cuts are made with a computer-controlled Gregori Impala bridge saw accurate to 0.0004 inch. The bridge saw is used to cut polished slabs into special shapes. Ashlar is made by breaking thick travertine slabs in a hydraulic knife or guillotine (Fig. 16). Finished slabs or blocks are packed or placed on pallets and shipped to customers.

Travertine is porous and its physical properties vary more than those of denser materials (Table 4). This is par-



FIGURE 13—After cutting, large travertine slabs are tipped over, onto cushioning debris, using hydraulic wedges before processing into blocks or rubble.





FIGURE 14—Adjustable Gaspari gang saw used to cut stone blocks into slabs. The block was about 4 ft wide before it was slabbed.

ticularly true of its modulus of elasticity and coefficient of linear expansion. Much travertine is used as flooring; porosity is not deleterious for this end use as shown by the much higher abrasion resistance of porous Santa Fe Ivory compared to Apache Golden Vein with far fewer visible pores.

**Tile line**—NMT has recently added over 15,000 ft<sup>2</sup> of floorspace to its processing plant. The addition encloses

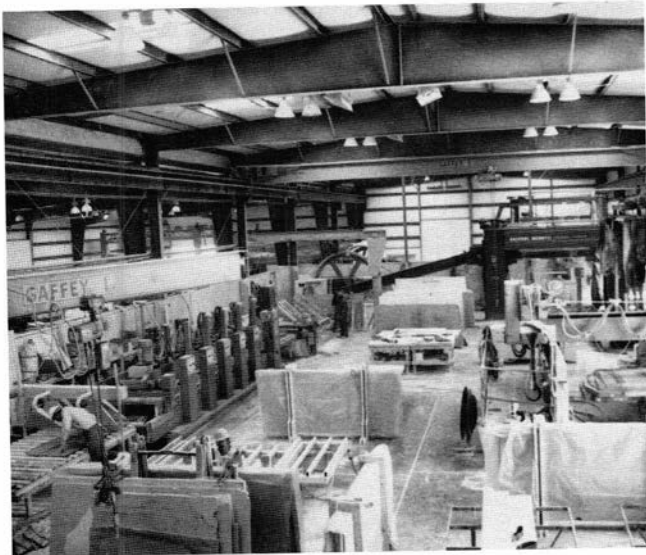

FIGURE 15—Gregori polishing line used to produce highly finished tiles.



FIGURE 16—Workmen breaking sawed blocks unsuitable for slabbing into split-face ashlar, which is placed on pallets for shipment to customers.

a line capable of taking stone from rough-shaped blocks to finished 12 x 12 x 3/8 inch tile. The tile line is capable of producing 12 x 12 x 3/8 inch to 24 x 24 x 3/4 inch tiles. This line is the only tile line in the western United States. When fully operational, it will have a capacity of 2,000 ft<sup>2</sup> per day. At present NMT is producing only limestone tiles from this line.

Rough blocks are cut into thin strips of stone (12 x 120 x 3/8 inches) called billets, using a Pedrini block saw (Fig. 17). The block saw uses up to 30 vertical circular diamond blades to saw the billets and one horizontal blade to cut the billet free of the block. From the block saws, the billets are moved to the beginning of the automatic line. The billets are first trimmed to square the ends so the stone can be butted end to end and run through the line. The next machines in sequence are a one-head grinder and seven-head polishing machine (Fig. 18). From the polisher, the stone billets run through a two-head rip saw that cuts the strips to exact widths. The next machine in sequence is a seven-head squaring saw that takes the strips and cuts them into tiles. The tiles move around the corner of the line and enter the final machine, a chamfering machine. The chamfering machine takes the individual tiles and gauges them square with a diamond grinding disk, and puts a slight bevel on two edges. The tiles move through the machine where they are turned 90° and the same process is performed on the other side.

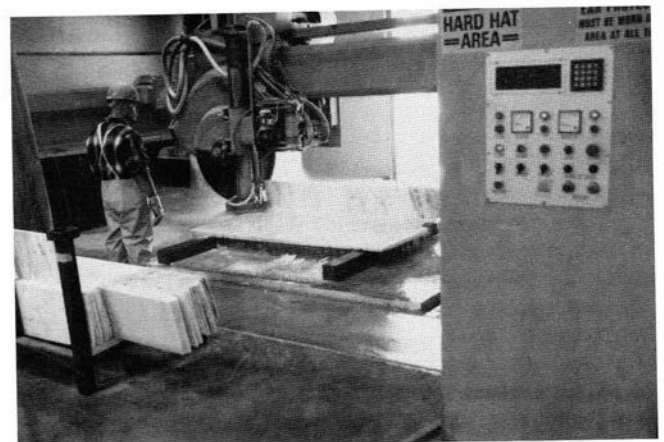

FIGURE 17—Rough stone blocks are cut into billets using a Pedrini block saw on the tile line of the NMT operation at Belen, New Mexico.

TABLE 4—Physical test data for NMT Temple Creme Travertine reported by Albuquerque Testing Labs [ATL], unless noted as completed by Testwell Craig [TC]. NMT Apache Golden Vein [AGV], concrete, and “marble” data included for comparison. **a**, North Carolina (NC), Vermont, or Georgia marble; **b**, 0.2 of ultimate compression; —, not available. Source: Austin and Barker, 1990.

Test	Procedure	Temple Creme			Other Materials			Remarks
		Mean Value	Range	Concrete	AGV	Marble <sup>a</sup>		
Compressive strength (psi)	ASTM C170-50	6,110	3,816 to 7,536	2,500 to 6,000	—	7,400 to 11,300	large voids = 3,815 horizontal grain	
Shear strength (psi)	Tinins Olsen tester	1,102	914 to 1,442	1,200 <sup>b</sup>	—	1,600 <sup>b</sup>		
Modulus of rupture (psi)	ASTM C99-52	1,105	992 to 1,133	750 to 900	—	7.8 to 3133	Horizontal grain eastern marble (NC) 718-3133 ±20% from mean allowed = all pass	
Modulus of elasticity	4" cubes in Tinins Olsen tester	0.92 x 10 <sup>6</sup>	0.56 to 1.3 x 10 <sup>6</sup>	3.5 to 5 x 10 <sup>6</sup>	—	7 x 10 <sup>6</sup>	horizontal grain low due to porosity	
Specific gravity	ASTM C97-83	2.37	2.37 [ATL] to 2.71 [TC]	2.32	2.48 [TC]	2.69 to 2.74		
Coefficient of linear expansion	heated 8 hours	1.391 x 10 <sup>6</sup>	0.9686 to 1.67 x 10 <sup>6</sup>	3.2 to 7.8 x 10 <sup>6</sup>	—	5.6 x 10 <sup>6</sup>		
Absorption	ASTM C97-83	0.92	0.89 to 0.97	—	—	—	Sample rejected as >15% below mean	
Abrasion resistance	ASTM C241	24.67 [TC]	—	—	11.37 [TC]	—		
Skid resistance	ASTM E303 (dry) ASTM C672 (wet)	39 [TC] 19 [TC]	— —	— —	— —	— —		
Scaling Resistance		0.1% loss	—	—	—	—	50 cycles	



TABLE 5—Travertine production by New Mexico Travertine. Data in short tons and by commercial name and product. Santa Fe Ivory replaced Temple Creme in 1990. Desert Creme was not produced after 1989.

	1985	1986	1987	1988	1989	1990	1991	1992	1993	1994
<b>Temple Creme/Santa Fe Ivory</b>										
slabs	6	84	247	134	433	234	242	96	196	54
ashlar	0	0	313	313	301	192	704	733	94	77
rubble	125	370	190	246	160	196	348	242	96	91
crushed	<u>23</u>	<u>0</u>	<u>47</u>	<u>25</u>	<u>0</u>	<u>38</u>	<u>184</u>	<u>98</u>	<u>87</u>	<u>30</u>
<b>total</b>	<b>154</b>	<b>454</b>	<b>797</b>	<b>718</b>	<b>894</b>	<b>660</b>	<b>1478</b>	<b>1169</b>	<b>473</b>	<b>252</b>
<b>Scheherazade</b>										
slabs	1	8	35	29	47	145	127	77	19	26
ashlar	0	0	0	125	341	474	236	225	204	204
rubble	64	194	440	205	149	140	456	228	199	123
crushed	<u>8</u>	<u>30</u>	<u>118</u>	<u>127</u>	<u>57</u>	<u>192</u>	<u>162</u>	<u>158</u>	<u>105</u>	<u>146</u>
<b>total</b>	<b>73</b>	<b>232</b>	<b>593</b>	<b>486</b>	<b>594</b>	<b>951</b>	<b>981</b>	<b>688</b>	<b>527</b>	<b>499</b>
<b>Vista Grande</b>										
slabs	16	37	3	5	6	20	20	43	3	25
ashlar	0	0	0	0	10	12	30	40	25	92
rubble	397	302	478	391	495	399	138	124	85	80
crushed	<u>304</u>	<u>731</u>	<u>2281</u>	<u>872</u>	<u>746</u>	<u>652</u>	<u>0</u>	<u>0</u>	<u>31</u>	<u>48</u>
<b>total</b>	<b>717</b>	<b>1070</b>	<b>2762</b>	<b>1268</b>	<b>1257</b>	<b>1083</b>	<b>188</b>	<b>207</b>	<b>144</b>	<b>245</b>
<b>Desert Gold/Desert Creme</b>										
slabs	11	25	5	11	60	17	5	6	12	4
ashlar	0	0	0	0	0	35	44	41	54	30
rubble	64	103	2401	309	211	134	82	109	182	90
crushed	<u>0</u>	<u>0</u>	<u>0</u>	<u>0</u>	<u>0</u>	<u>0</u>	<u>759</u>	<u>774</u>	<u>261</u>	<u>645</u>
<b>total</b>	<b>76</b>	<b>128</b>	<b>2406</b>	<b>320</b>	<b>271</b>	<b>186</b>	<b>890</b>	<b>930</b>	<b>509</b>	<b>769</b>
<b>Apache Golden Vein</b>										
slabs	4	21	39	11	13	20	5	14	3	6
ashlar	0	0	0	0	0	0	149	72	0	8
rubble	<u>0</u>	<u>0</u>	<u>0</u>	<u>0</u>	<u>0</u>	<u>0</u>	<u>0</u>	<u>0</u>	<u>0</u>	<u>9</u>
<b>total</b>	<b>4</b>	<b>21</b>	<b>39</b>	<b>11</b>	<b>13</b>	<b>20</b>	<b>154</b>	<b>86</b>	<b>3</b>	<b>23</b>
<b>TOTAL</b>	<b>1026</b>	<b>1905</b>	<b>6597</b>	<b>2802</b>	<b>3029</b>	<b>2900</b>	<b>3691</b>	<b>3080</b>	<b>1656</b>	<b>1788</b>

Upon leaving the chamfering machine, the tile is dried, and buffed on two additional machines and finally packaged at the end of the line (Fig. 19).

**Stone production by NMT—Production** records of NMT for the last 10 years (Table 5) show sales of seven commercial varieties of New Mexico stone and four types of product: slabs, ashlar, rubble, and crushed stone. Apache Golden Vein is included for completeness, but it is an altered limestone, not a travertine.

Data for Temple Creme and Santa Fe Ivory and for Desert Gold and Desert Creme are combined. Produc

tion trends show a general increase in all travertine varieties since start up, particularly for Vista Grande, Temple Cream/Santa Fe Ivory, and Scheherazade through 1992. Vista Grande and Desert Gold/Desert Creme were very popular in 1987, principally as crushed and rubble respectively. Until 1993 production of slabs (the most expensive travertine product) rose substantially for all varieties except Vista Grande. Temple Creme slabs were the most popular, but the lack of high-quality reserves curtailed sales. Santa Fe Ivory has replaced Temple Creme as NMT's premier white travertine but presently is on

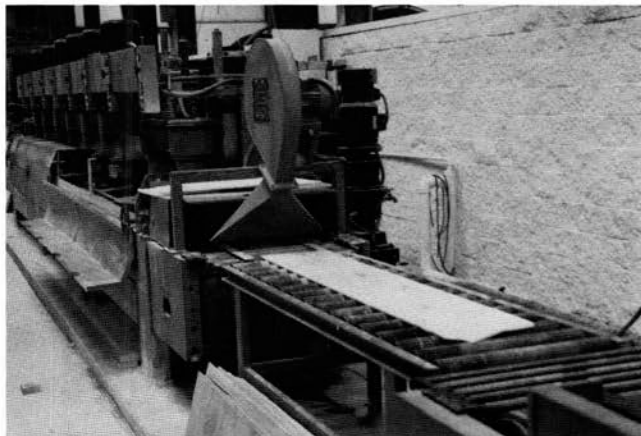

FIGURE 18—One surface of the billets cut in Figure 17 are finished on the seven head polishing machine of the NMT tile line.



FIGURE 19—Square tiles are packaged, at the end of the tile line, for shipment to customers.

standby while light-colored travertine resources are developed. In 1994 Scheherazade was the most popular travertine in both the ashlar and rubble categories. The production of rubble has varied widely among the five types of stone used, but Vista Grande was most popular in late 1980s. Crushed travertine production was volatile over the 10 year period, with Vista Grande and Desert Gold particularly popular in 1987. In 1994 Desert Gold/Desert Creme were the most popular. In recent years total New Mexico travertine production has decreased to 20% of total NMT production.

Due to market and trend changes in natural stone, limestone has become very popular as dimensional stone products for paving and cladding. With the huge reserves of limestone in the United States and few operations sawing the stone thin into slabs and tiles, NMT took the initiative and started bringing in stone from Indiana, Kansas, Texas, and Oklahoma to saw into thin dimensional products. In four short years, limestone has become a very large segment of NMT's activity. Along with fabricating limestone, NMT is also producing marble slabs and soon tile for Colorado Yule Marble Company. NMT is also producing cut-to-size projects out of Colorado Yule and Vermont marbles.

The new tile line is producing only limestone tiles and much of the slab production is not from New Mexico stone. NMT cuts a great deal of Indiana Limestone. The names of this stone are varied, but it all comes from the Bedford /Bloomington area where producers call it Standard Buff (NMT calls it Sterling) and Standard Gray (NMT's name is Windsor Select). When the "hard top" of Indiana is sold by NMT, it is processed and marketed as Yukon Silver. This latter stone is waste in Indiana. NMT is marketing this Indiana stone because it is inexpensive, it can be cut thin, and they do not have to spend time and expense filling voids as is done with the travertine.

NMT buys and cuts other stone, principally from Texas, Oklahoma, and Kansas. The Texas stones are: Adobe Rose, Valencia Ivory, Flamingo Rose, Fossil Beach (Big Spring), Classic Gray (Ablene), and Texas Cream and Texas Shell (Austin). The last two stones used to be called Cordova Cream and Cordova Shell. NMT gets Plaza Gray and Hillsboro stone from eastern Kansas, and Sebastian from Oklahoma.

NMT has recently purchased the old Siaz quarry at Abo Pass about 20 mi southeast of Belen and north of U.S. Highway 60. They plan to start quarrying the rock called Silver Mist. It is a greenish-gray chloritic schist that was marketed as a flagstone and building stone in the past.

Rocky Mountain Stone Company (RMS) markets stone for NMT in New Mexico. Finished travertine is displayed at the RMS stoneyard on the Pan American Highway just west of Interstate 25 south of the Jefferson exit in Albuquerque. Some travertine is shipped to sculptors for carving or to marble shops and dealers primarily for distribution to furniture manufacturers. RMS aggressively markets their products in many parts of the United States and has sold large quantities of stone in such distant states as New Jersey and Washington. RMS travertine products are now beginning to penetrate international stone markets as well.

#### Acknowledgments

We benefited significantly from interviews with Tim, Dave, and Jim Lardner of New Mexico Travertine and by reviews of our colleagues Gretchen Hoffman and Edward Smith.

#### References

- Adams, J. W., Love, D. W., and Hawley, J. W., 1993, Third-day roadlog, from Carlsbad to Dark Canyon, Last Chance Canyon, Sitting Bull Falls, Rocky Arroyo, and return to Carlsbad: New Mexico Geological Society, Guidebook 44, pp. 69-86.
- Anderson, O. J., 1987, Geology and coal resources of Atarque Lake 1:50,000 quadrangle, New Mexico: New Mexico Bureau of Mines and Mineral Resources, Geologic Map 61, scale 1:50,000.
- Austin, G. S., and Barker, J. M., 1990, Commercial travertine in New Mexico: New Mexico Geology, v. 12, pp. 49-58.
- Austin, G. S., Barker, J. M., and Smith, E. W., 1990, Building with stone in northern New Mexico: New Mexico Geological Society, Guidebook 41, pp. 405-415.
- Barker, J. M., 1983, Preliminary investigation of the origin of the Riley travertine, Socorro County, New Mexico: New Mexico Geological Society, Guidebook 34, pp. 269-276.
- Barker, J. M., 1986, Travertine: New Mexico Bureau of Mines and Mineral Resources, Open-file Report 229, pp. 94-100.
- Barker, J. M., 1988, Travertine quarries and deposits in New Mexico (abs.): New Mexico Geology, v. 10, p. 68.
- Barker, J. M., and Austin, G. S., 1994, Stone, decorative; in Carr, D. D. (ed.), 6th ed.: Society for Mining, Metallurgy, and Exploration, Littleton, Colorado, pp. 367-378.
- Bingler, E. C., 1968, Geology and mineral resources of Rio Arriba County, New Mexico: New Mexico Bureau of Mines and Mineral Resources, Bulletin 91, 158 pp.
- Bolton, R., 1993, Depositional textures and stable isotopic composition of the Riley travertine: Unpublished MS thesis, New Mexico Institute of Mining and Technology, 113 pp.
- Boyd, F. S., and Wolf, H. D., 1953, Recent investigations of radioactive occurrences in Sierra, Dona Ana, and Hidalgo counties, New Mexico: New Mexico Geological Society, Guidebook 4, pp. 141-142.
- Chafetz, H. S., and Folk, R. L., 1984, Travertine depositional morphology and the bacterial constructed constituents: Journal of Sedimentary Petrology, v. 54, pp. 289-316.
- Chafetz, H. S., Utech, N. M., and Fitzmaurice, S. P., 1991, Differences on the  $^{618}\text{O}$  and  $^{613}\text{C}$  signatures of seasonal laminae comprising travertine stromatolites: Journal of Sedimentary Petrology, v. 61, pp. 1015-1028.
- Clemons, R. E., 1976, Geology of east half Corralitos Ranch quadrangle, New Mexico: New Mexico Bureau of Mines and Mineral Resources, Geologic Map 36, scale 1:24,000, 2 sheets.
- Colpitts, R. M., Austin, G. S., Barker, J. M., Bauer, P. W., Hahman, W. R., Hawley, J. W., and Lozinsky, R. P., 1991, Road log from Inn of the Mountain Gods to Bent dome, Tularosa, Alamogordo, Cloudcroft, and return to the Inn of the Mountain Gods: New Mexico Geological Society, Guidebook 42, pp. 1-25.
- Cooper, B. N., 1964, Deposits of travertine, onyx, and marble along the east base of Mesa Aparejo, Valencia County, New Mexico: Unpublished report for Ultra Marble Inc., Albuquerque, 66 pp.
- Cummings, D., 1968, Geologic map of the Zuni Salt Lake volcanic crater, Catron County, New Mexico: U.S. Geological Survey, Map 1-554, scale 1:6,000.
- Drewes, H. and Thorman, C. H., 1980, Geologic map of the Cotton City quadrangle and the adjacent part of the Vanar quadrangle, Hidalgo County, New Mexico: U.S. Geological Survey, Map 1-1221, scale 1:24,000.
- Elston, W. E., 1957, Geology and mineral resources of Dwyer quadrangle, Grant, Luna, and Sierra Counties, New Mexico: New Mexico Bureau of Mines and Mineral Resources, Bulletin 38, 86 pp.
- Fiedler, A. G., and Nye, S. S., 1933, Geology and ground-water resources of the Roswell artesian basin, New Mexico: U.S. Geological Survey, Water-supply Paper 639, 372 pp.
- File, L., and Northrup, S. A., 1966, County, township, and range locations of New Mexico's mining districts: New Mexico Bureau of Mines and Mineral Resources, Circular 84, 66 pp.
- Fisher, R. A., 1979, A biochemical study of the Recent calcite deposits along the Lucero uplift, Valencia County, New

- Mexico: Unpublished MS thesis, New Mexico Institute of Mining and Technology, 152 pp.
- Fitzmaurice, S. P., 1990, The petrography, geochemistry, and depositional environments of travertines of the Palm Park Formation (Eocene), Caballo Mountains, New Mexico: Unpublished MS thesis, University of Houston, 316 pp.
- Folk, R. L. 1993, SEM imaging of bacteria and nannobacteria in carbonate sediments and rocks: *Journal of Sedimentary Petrology*, v. 63, pp. 990-999.
- Gillerman, E., 1964, Mineral deposits of western Grant County, New Mexico: New Mexico Bureau of Mines and Mineral Resources, Bulletin 83, 213 pp.
- Goff, F., and Shevenell, L., 1987, Travertine deposits of Soda Dam, New Mexico, and their implications for the age and evolution of the Valles caldera hydrothermal system: *Geological Society of America Bulletin*, v. 99, pp. 292-302.
- Grant, P. R., Jr., 1982, Geothermal potential in the Albuquerque area, New Mexico: New Mexico Geological Society, Guidebook 33, pp. 325-331.
- Griswold, G. B., 1961, Mineral deposits of Luna County, New Mexico: New Mexico Bureau of Mines and Mineral Resources, Bulletin 72, 157 pp.
- Hahman, W. R., and Colpitts, R. M., 1991, Engineering geology of karst collapse features in a highway roadcut quarry, Otero County, New Mexico: New Mexico Geological Society, Guidebook 42, pp. 24-25.
- Hammond, C. M., 1987, Geology of the Navajo Gap area between the Ladrone Mountains and Mesa Sarca, Socorro County, New Mexico: Unpublished MS thesis, New Mexico Institute of Mining and Technology, 212 pp.
- Harrington, E. R., 1948, Craters and crater springs of the Rio Salado: *Journal of Geology*, v. 56, no. 3, pp. 182-185.
- Hedlund, D. C., 1978, Geologic map of the Ninety-six Ranch quadrangle, Grant County, New Mexico: U.S. Geological Survey, Map MF-1034, scale 1:24,000.
- Jicha, H. L., Jr., 1956, A deposit of high-calcium lime rock in Valencia County, New Mexico: New Mexico Bureau of Mines and Mineral Resources, Circular 36, 5 pp.
- Jicha, H. L., Jr., 1958, Geology and mineral resources of Mesa del Oro quadrangle, Socorro and Valencia Counties, New Mexico: New Mexico Bureau of Mines and Mineral Resources, Bulletin 56, 67 pp.
- Julia, R., 1983, Travertines: American Association of Petroleum Geologists, Memoir 33, pp. 64-72.
- Kelley, V. C., 1977, Geology of the Albuquerque Basin, New Mexico: New Mexico Bureau of Mines and Mineral Resources, Memoir 33, 60 p.
- Kelley, V. C., and Wood, G. H., 1946, Geology of the Lucero uplift, Valencia, Socorro, and Bernalillo Counties, New Mexico: U.S. Geological Survey, Oil and Gas Investigations, Preliminary Map 47, scale 1:63,360.
- Kelley, V. C., Woodward, L. A., Kudo, A. M., and Callender, J. F., 1976, Guidebook to the Albuquerque Basin of the Rio Grande rift, New Mexico: New Mexico Bureau of Mines and Mineral Resources, Circular 153, 31 pp.
- King, P. B., 1948, Geology of the southern Guadalupe Mountains, Texas: U.S. Geological Survey, Professional Paper 215, 183 pp.
- King, W. E., and Kelley, R. E., 1980, Geology and paleontology of Tortugas Mountain, Dona Ana County, New Mexico: *New Mexico Geology*, v. 2, pp. 33-35.
- Kottlowski, F. E., 1962, Reconnaissance of commercial high-calcium limestones in New Mexico: New Mexico Bureau of Mines and Mineral Resources, Circular 60, 77 pp.
- Kottlowski, F. E., 1965, Limestone and dolomite; *in* Mineral and water Resources of New Mexico: New Mexico Bureau of Mines and Mineral Resources, Bulletin 87, pp. 345-353.
- Kues, B. S., Lucas, S. G., and Ingersoll, R. V., 1982, Lexicon of Phanerozoic stratigraphic names used in the Albuquerque area: New Mexico Geological Society, Guidebook 33, pp. 125-138.
- Lambert, S. J., Harvey, D. M., 1987, Stable isotope geochemistry of ground waters in the Delaware Basin of southeastern New Mexico: Sandia National Laboratories, Sandia Report SAN87-0138.UC-70, pp. 42-51.
- Maxwell, C. H., 1988, Geologic map of the Marmon Ranch quadrangle, Cibola County, New Mexico: U.S. Geological Survey, Map MF-209, 1:24,000.
- McLemore, V. T., and Sutphin, D. M., 1996, Geology and mineral occurrences of the mining districts; *in* Bartsch-Winkler, S. (ed.), Mineral resources of the Mimbres resource area, Grant, Luna, Hidalgo, and Dona Ana Counties, New Mexico: U.S. Geological Survey, Open-file Report, in press.
- O'Sullivan, R. B., Weide, D. L., and Scott, G. R., 1989, Preliminary geologic map of the Grey Hill Spring quadrangle, San Juan and McKinley Counties, New Mexico: U.S. Geological Survey, Map MF-2069, scale 1:24,000.
- Reiche, P., 1949, Geology of the Manzanita and north Manzano Mountains, New Mexico: *Geological Society of America Bulletin*, v. 60, pp. 1183-1212.
- Renick, B. C., 1926, Geology of the ground-water resources of the drainage basin of the Rio Peñasco above Hope, New Mexico: 7th Biennial Report of the State Engineer of New Mexico, pp. 113-137.
- Sanders, J. E., and Friedman, G. M., 1967, Origin and occurrence of limestones; *in* Chilingar, G. V., Bissell, H. J., and Fairbridge, R. W. (eds.), Carbonate rocks, origin and classification, Developments in Sedimentology 9A: Elsevier, New York, pp. 176-177.
- Seager, W. R., 1975, Geologic map and sections of south half San Diego Mountain quadrangle, New Mexico: New Mexico Bureau of Mines and Mineral Resources, Geologic Map 35, scale 1:24,000.
- Seager, W. R., and Mack, G. H., 1994, Geology of East Potrillo Mountains and vicinity, Dona Ana County, New Mexico: New Mexico Bureau of Mines and Mineral Resources, Bulletin 113, 27 pp.
- Seager, W. R., Hawley, J. W., and Clemons, R. E., 1971, Geology of San Diego Mountain area, Dona Ana County, New Mexico: New Mexico Bureau of Mines and Mineral Resources, Bulletin 97, 38 pp.
- Slack, P. B., and Campbell, J. A., 1976, Structural geology of the Rio Puerco fault zone and its relationship to central New Mexico tectonics: New Mexico Geological Society, Special Publication 6, pp. 46-52.
- Summers, W. K., 1965, Chemical characteristics of New Mexico's thermal waters-A critique: New Mexico Bureau of Mines and Mineral Resources, Circular 83, 27 pp.
- Summers, W. K., 1976, Catalog of thermal waters in New Mexico: New Mexico Bureau of Mines and Mineral Resources, Hydrologic Report 4, 80 pp.
- Szypula, A., 1988, Self evaluation of Temple Creme and Apache Golden Vein: [Unpublished report], Testwell Craig Laboratories, 4 pp.
- Thaden, R. E., Santos, E. S., and Raup, O. B., 1967, Geologic map of the Grants quadrangle, Valencia County (now Cibola), New Mexico: U.S. Geological Survey, Map GQ-681, 1:24,000.
- Titus, F. B., Jr., 1963, Geology and ground-water conditions in eastern Valencia County, New Mexico: New Mexico Bureau of Mines & Mineral Resources, Ground-water Report 7, 113 pp.
- White, W. D., 1989, Geohydrologic and environmental indicators of a dewatered wetland-Ojo del Gallo, San Rafael, New Mexico: New Mexico Geological Society, Guidebook 40, pp. 337-345.
- Woodward, L. A., 1987, Geology and mineral resources of Sierra Nacimiento and vicinity, New Mexico: New Mexico Bureau of Mines and Mineral Resources, Memoir 42, 84 pp.
- Woodward, L. A., DuChene, H. R., and Martinez, R., 1977, Geology of the Gilman quadrangle: New Mexico Bureau of Mines and Mineral Resources, Geologic Map 45, scale 1:24,000.
- Woodward, L. A., and Martinez, R., 1974, Geologic map and sections of Holy Ghost Spring quadrangle, New Mexico: New Mexico Bureau of Mines and Mineral Resources, Geologic Map 33, scale 1:24,000.
- Woodward, L. A. and Reutschilling, R. L., 1976, Geology of San

- Ysidro quadrangle, New Mexico: New Mexico Bureau of Mines and Mineral Resources, Geologic Map 37, scale 1:24,000.
- Wright, H. E., Jr., 1946, Geology of lower Rio Puerco area: Geological Society of America, Bulletin, v. 57, pp. 383-456.
- Zilinsky, R. and Callender, J., 1976, Geology of the Carrizo Arroyo area, Lucero uplift, Valencia Co., New Mexico: New Mexico Bureau of Mines and Mineral Resources, Circular 153, pp. 14-15.

# Limestones of New Mexico and adjoining areas suitable for sulfur removal in coal-fired power plants

Frank E. Kottowski<sup>1</sup> and Augustus K. Armstrong<sup>2</sup>

<sup>1</sup>New Mexico Bureau of Mines & Mineral Resources, New Mexico Tech, 801 Leroy Place, Socorro, New Mexico 87801-4796, USA;

<sup>2</sup>U. S. Geological Survey, Menlo Park, California 94025, USA

**Abstract**—Widespread high-calcium limestones in the New Mexico region are low in magnesium, but some units include shale interbeds deleterious for sulfur removal. Thick limestones in the Mississippian Escabrosa, Lake Valley, and Leadville Limestones, Pennsylvanian Madera and Hermosa Formations, Pennsylvanian–Permian Horquilla Limestone, Permian Hueco Formation and Capitan Limestone, Cretaceous U-Bar Formation, and some Cenozoic travertines are high-calcium units. Significant outcrops are in mountains of southwestern, south-central, central, southeastern and north-central New Mexico, southeastern Arizona, southwestern Colorado, and northwestern Chihuahua. Coal-fired powerplants are mainly in northwestern New Mexico and eastern Arizona, and transport is therefore mainly by railroad.

## Calizas de Nuevo México y áreas vecinas idóneas para desulfurización en plantas de energía eléctrica alimentadas con carbón

**Resumen**—Calizas de elevado contenido de calcio pero bajas en magnesio son muy difundidas en Nuevo México. Algunas unidades contienen intercalaciones arcillosas nocivas para la remoción del azufre. Calizas gruesas de elevado contenido de calcio se encuentran en las formaciones siguientes: *Escabrosa*, *Lake Valley* y *Leadville* del Mississipiano; *Madera* y *Hermosa* del Pennsylvaniano, *Horquilla* del Pennsylvaniano–Pérmico; *Hueco* y *Capitán* del Pérmico; *U-Bar* del Cretácico y algunos travertinos cenozoicos. Afloramientos importantes existen en las montañas del suroeste, centro sur, centro, sureste y centro norte de Nuevo México, así como en el sureste de Arizona, suroeste de Colorado y noroeste de Chihuahua. Las plantas de energía eléctrica que queman carbón se encuentran principalmente en el noroeste de Nuevo México y este de Arizona, razón por la cual el transporte de la caliza es principalmente por ferrocarril.

### Introduction

Reconnaissance sampling of high-calcium (HC) limestones in New Mexico has been reported by Siemers (1982), Jicha (1956), and Kottowski (1962). Numerous articles describe the limestone units in and near the state, such as Armstrong (1958) for west-central New Mexico, Mississippian and Pennsylvanian Systems in the state (Armstrong et al., 1979), Pennsylvanian units in south-central New Mexico (Wilson, 1989), Pennsylvanian strata in southwestern New Mexico and southeastern Arizona (Kottowski, 1960), Pennsylvanian section in the Big Hatched Mountains (Thompson and Jacka, 1981), Paleozoic strata in the Big Hatched Mountains (Zeller, 1965), Mississippian in southwestern New Mexico and southeastern Arizona (Armstrong, 1962, 1978), Mississippian in the San Juan Mountains (Armstrong, 1978), Mississippian and Pennsylvanian rocks in the Sangre de Cristo Mountains (Sutherland, 1963), Pennsylvanian System in New Mexico (Bachman, 1975), Pennsylvanian and Wolfcampian rocks in southeastern New Mexico (Meyer, 1966), Paleozoic rocks in the Manzano Mountains (Myers, 1973), and Paleozoic strata in the Sacramento Mountains (Pray, 1961). Other shorter articles report on Paleozoic outcrops of individual quadrangles, and numerous reports detail the thick Permian strata in southeastern New Mexico in the Guadalupe Mountains; many of these Permian carbonate rocks are dolomite or dolomitic.

HC limestones are best used in sulfur removal, either directly or converted to lime. The latter is an important basic chemical utilized also in production of glass, paper, alkalis, metallurgical flux, calcium carbide, and for water purification. The copper smelters in southwestern New Mexico are heavy users of lime for flux. HC limestone may meet the requirements of dimension stone and can be used as crushed stone for aggregate, to make cement, and as "lime" for soil conditioning, although less-pure limestone can be quarried for these purposes.

HC limestone contains at least 95% calcium carbonate (about 53.22 % CaO) and less than 3–5% magnesium carbonate; limits for other impurities are: alumina, 1%; silica, 2%; sulfur, 0.05%; phosphorus, 0.02%; and iron oxide, about 1%. The chemical and physical requirements differ slightly depending upon the end use.

Quick and hydrated lime, obtained by calcination of HC limestone, are low-cost, unstable, perishable products. Safe transportation is expensive and, considering the low value of the bulk material, makes shipping over long distances uneconomical. New Mexico, with only two large metropolitan centers (Albuquerque and El Paso) in or close to the state and relatively sparse industry, is unfavorably located for most large usage of chemical- and industrial-grade lime, except for cement plants. However, the lack of a lime-producing plant in New Mexico has

resulted in long-distance shipping from Arizona to a powerplant in the Four Corners region of northwestern New Mexico.

### Usage for flue-gas desulfurization

The Clean Air Act of 1990 established requirements for electric utilities requiring SO<sub>2</sub> emissions to be halved by flue-gas cleaning systems and fuel modifications. These apply to all powerplants, even those fired by low-sulfur (1%) coal. Using limestone in scrubber systems can remove 95% of the sulfur, and lime (CaO) can remove 98%.

General estimates are that removal of 1 short ton (st) of sulfur takes 4 st of limestone and can result in 14 st of waste material consisting largely of impure gypsum. In regions where landfill sites are costly (perhaps as much as \$250,000 per acre), production of byproduct gypsum may be a financial alternative to throwaway solid waste (Ellison and Kuntze, 1993).

Most limestone used for scrubbers should be 93-96% calcium carbonate, have less than 3-6% magnesium carbonate, and be free of fluorine, selenium, and mercury. New Mexico has numerous large deposits of gypsum (Weber and Kottowski, 1959), therefore flue-gas desulfurization byproduct gypsum, mainly to produce gypsum board and portland cement, probably would not be competitive.

New Mexico has three large coal-fired powerplants. In the northwestern corner of the state west of Farmington are the Four Corners Plant (Arizona Public Service Company), and the San Juan Plant (Public Service Company of New Mexico). The Escalante Plant (Plains Electric Cooperative) is in west-central New Mexico, between Grants and Gallup.

The Four Corners Plant can produce 2,269 megawatts (MW) of electricity and uses about 8,500,000 st of coal per year from the adjoining Navajo mine of (BHP-Utah International Inc.). The coal averages about 8,750 Btu/lb, 0.78% sulfur, and 22.2% ash. To reduce the sulfur emissions, the plant uses lime from Tucson, Arizona. The lime is shipped by railroad to Gallup, New Mexico, then hauled by truck to the powerplant. Waste from the scrubbers is thickened to almost solid calcium sulfate, fly ash is added and then trucked to the Navajo mine and deposited in the stripped pits.

The San Juan Plant is rated at 1,710 MW and uses about 6,000,000 st of coal per year from the adjoining San Juan mine and the nearby La Plata mine, both operated by BHP-Utah International Inc. The coal contains about 9,540 Btu/lb, 0.74% sulfur, and 21.3% ash. Soda ash trucked from Wyoming is used in the scrubbers to produce sulfuric acid. Fly ash is placed in the stripped pits of the San Juan mine.

The Escalante Plant, rated at 235 MW, uses about 890,000 st of coal per year, shipped by rail from the Lee Ranch mine (Hanson Natural Resources Company). The coal yields about 9,420 Btu/lb, 0.7% sulfur and 15.7% ash. Limestone (Permian San Andres Limestone) for the plant is quarried on the southwest side of the Zuni Mountains, trucked to the plant, and added to the scrubber system. The calcium sulfate waste sludge is placed in a landfill and covered by soil and vegetation. All of the fly ash is shipped via railroad and truck to the Tijeras cement plant (Rio Grande Cement) east of Albuquerque.

In eastern Arizona, three powerplants near New Mexico are supplied with New Mexico coal. These are the Cholla Plant (Arizona Public Service Company) at Joseph City;

the Coronado Plant (Salt River Project) near St. John, and the Apache Station Plant (Arizona Electric Power Cooperative) near Cochise.

### Distribution of limestones

Limestones crop out or are near the surface in about 25% of the state; they range in age from thin dolomitic limestone lenses in the Cambrian part of the Bliss Sandstone to Cenozoic travertine, calcareous tufa, and caliche. Some of the HC limestones of Mississippian, Pennsylvanian, Permian, and Early Cretaceous ages exceed 100 ft in thickness, and locally 1,000 ft. Their purity ranges from almost pure calcite to calcareous tufa and caliche, which in places contain as much as 40% insoluble residues.

Locating outcrops of HC limestone is no problem, but the most economical deposits should fulfill three requirements: (1) be easily mined by open-pit methods i.e. cap extensive mesas and underlie thin overburden; (2) be within 20 mi of a railroad and accessible by good trucking roads; and (3) be within short distance of a natural gas pipeline. The intersections of highways, railroads, and natural gas pipelines with limestone-outcrop areas determined which of the deposits were investigated. Some limestones in relatively inaccessible areas were sampled to obtain a fairly complete stratigraphic coverage of limestones in the state.

Limestones checked and sampled as possible economic HC deposits include: Cenozoic travertine of the Lucero Mesa, Mesa del Oro, and Ladron Mountain areas; the caliche "caprock" of the Llano Estacado; the Tertiary algal limestone of Apache Valley; limestone beds in the northern and central New Mexico Upper Cretaceous sequence; the Lower Cretaceous limestones of southwestern New Mexico; the Jurassic Todilto Limestone southeast of Grants and east of Santa Rosa; favorable Permian, Pennsylvanian, and Mississippian limestones in the Robledo, Guadalupe, Sacramento, Peloncillo, Florida, Tres Hermanas, Oscura, Sandia, Manzano, Sangre de Cristo, Ladron, and Magdalena Mountains, Border Hills, Cerros de Amado, and near Luna; and the El Paso Limestone in the Victorio Mountains. The samples collected are too few to completely test the limestones in these areas and are only a rough guide to commercial possibilities.

### Pre-Mississippian limestones

Small lenses of carbonate rocks, dolomitic in most places, are present amid rocks of Precambrian age in widely scattered areas of southern New Mexico, as in the Redrock area and near Hembrillo Canyon in the central San Andres Mountains. Thick Precambrian quartzite and schist sequences of the central and northern parts of the state lack appreciable amounts of limestone.

Fossiliferous pre-Mississippian post-Precambrian strata crop out only in southwestern and south-central New Mexico, the northeasternmost outcrops being in the northern San Andres and southern Oscura Mountains. The oldest unit is the Bliss Sandstone, of Cambrian and Ordovician ages; locally, a few limy beds are present near the top of the sandstone *sensu stricto*. The overlying El Paso Limestone and Montoya Dolomite, both of Ordovician age, are chiefly dolomite and magnesium limestone. The El Paso Limestone may contain some local HC limestone beds; it thickens, under a pre-Montoya erosion surface, from a knife edge at the northern sections (in the northern San Andres Mountains) to more than 1,400 ft

near El Paso, and is about 800 ft thick in the latitudes of Las Cruces and Deming. Analyses of limestones of the El Paso Limestone from scattered localities (Kottlowski, 1957) show more than 10% magnesium carbonate, and in most samples at least 5-10% insoluble residues, chiefly silt-size quartz. Selected limestones from the El Paso Limestone in the Victorio Mountains, however, contain almost 94% calcium carbonate.

Except for a few beds of impure limestone in the upper Cutter Formation, the Montoya Dolomite is entirely dolomite or dolomitic limestone (except for basal dolomitic sandstones), although locally some beds are magnesium limestone. Limestones in the Montoya from the Cooks Peak and other areas contain more than 5% magnesium carbonate.

The Silurian Fusselman Dolomite is more than 800 ft thick in the triangular area from the Victorio Mountains southeast to the Franklin Mountains, but it thins rapidly northward and westward as a result of erosion during Early Devonian and/or Late Silurian time. Some of its carbonate-rock beds are as calcic as dolomitic limestone, but all units appear to be high in magnesium (Kottlowski, 1957), with dolomite dominating. Devonian rocks typically are calcareous shales and calcareous siltstones; the only limestone beds are impure, thin, and lenticular. Silty dolomites, however, are present in the Oñate Formation. Pre-Mississippian limestones are not likely sources of HC lime in New Mexico.

### Mississippian limestones

Mississippian strata in northern and central New Mexico crop out as discontinuous remnants beneath an erosion surface of Late Mississippian and Early Pennsylvanian ages (Armstrong, 1955, 1958). Some of the crinoidal calcarenites in the Sandia, Ladron, Magdalena, Nacimiento, and Sangre de Cristo Mountains appear to be relatively HC limestone, except for sparse to abundant chert lenses and nodules. Locally, these encrinites are thick (20-50 ft) and cap low benches below ledges and slopes eroded on the shaly lower Pennsylvanian strata. Samples from cherty Mississippian limestones near Bishop's Lodge (Kottlowski, 1962) in the southwestern Sangre de Cristo Mountains and along Las Huertas Creek Canyon in the northeastern Sandia Mountains contained only 91% calcium carbonate, 2-6% magnesium carbonate, and 1.5-5.6% silica. These samples are representative of the total thickness of Mississippian limestones at these localities; selected purer samples have insoluble residues (quartz and clay) of 0.3-0.7%. In the southeastern Sangre de Cristo Mountains along Gallinas Canyon east of Montezuma, as reported by Baltz and Read (1960), the Cowles Member of the Tererro Formation (upper unit of the Mississippian) is as much as 40 ft thick and consists of a crinoidal calcarenite (grab sample) with an insoluble residue of about 0.6%.

The Mississippian Lake Valley Limestone exceeds 100 ft in thickness in the Sacramento Mountains (Pray, 1961), southern San Andres Mountains (Kottlowski et al., 1956), Cooks Peak-Lake Valley area (Jicha, 1954), and Silver City-Santa Rita district. Similar limestones, partly correlative with the Lake Valley Limestone, are placed in the Escabrosa Group by Armstrong (1962). This group includes as much as 1,000 ft of carbonate rocks in the Big Hatchet and Animas Mountains (Fig. 1) and Klondike Hills, and locally it may exceed 500 ft in the Peloncillo and Tres Hermanas Mountains (Armstrong and Mamet,

1988). Analyses of these crinoidal strata show them to be HC; near Alamogordo millions of short tons are available near a gas line and railroad.

The Mississippian strata in the Franklin Mountains are mainly siliceous impure limestone of the Rancheria Formation. To the north along the Rio Grande, the Mississippian section is thin or absent in the Robledo and Caballo Mountains.

### Pennsylvanian limestones

The sedimentary beds of Pennsylvanian age are thick, though variable, in New Mexico (Thompson, 1942; Kottlowski, 1960; Read and Wood, 1947; Armstrong et al., 1979) and crop out in most of the major mountain ranges. Most of the formations include HC limestones, and in many areas these limestones underlie dip-slope mesas where they could be quarried from open pits after removal of thin overburden. Extensive outcrops of Pennsylvanian limestones are found in the Sangre de Cristo, Nacimiento, Sandia, Manzano, Los Pinos, Ladron, Magdalena, Oscura, San Andres, Sacramento, Franklin, Robledo, Big Hatchet, and Peloncillo Mountains, the Cerro de Amado, and the Silver City-Santa Rita area. Smaller outcrop areas are scattered in many other mountain ranges. An average section of the Pennsylvanian strata would be 1,000-3,000 ft thick and consist of a basal clastic unit in which most of the limestones are arenaceous, a thick medial unit of cherty to HC limestones, and an upper unit of interbedded marine limestones and shale-sandstone beds (i.e. siliciclastic beds). The medial unit makes ledgy cliffs in many mountain ranges. Dip slopes of the tilted fault-block ranges are, in many places, of massive limestones in the upper unit. The best locations for quarries (such as that of the Tijeras Cement Plant east of Albuquerque) are in HC limestones of the Middle Pennsylvanian, where the interbedded, shaly, clastic strata have been removed by erosion, leaving thick, pure limestones covered by only thin overburden. Such possible quarry locations are present in most of the mountain ranges listed.

### Permian limestones

The basal Permian strata in many parts of south-central New Mexico are the interbedded red beds and marine limestones of the Bursum Formation (Wilpolt and Wanek, 1952; Thompson, 1954). Southward from the Oscura Mountains, this formation and correlative units include some massive HC limestones that are near transportation facilities in the northern Sacramento Mountains (Otte, 1959) and Robledo Mountains (Kottlowski, 1960). The upper part of the Horquilla Limestone, containing hundreds of feet of massive limestone, is of Early Permian age in the Big Hatchet (Zeller, 1958) and Peloncillo Mountains.

The basal Permian in most of north-central New Mexico is within the Abo red beds, the Sangre de Cristo Formation, or the Cutler red beds. The Abo red beds grade southward into the Hueco Formation, which includes thick HC limestones in the San Andres (Kottlowski et al., 1956), Franklin (Harbour, 1960), Robledo, Dona Ana (Kottlowski 1960), Florida, and Tres Hermanas Mountains.

The Yeso Formation, conformable on the Abo red beds, consists of interbedded gypsum, brown sandstone, pinkish shale, and thin, impure limestone. The amount and thickness of the limestone units increase southward. In most areas, however, the limestones of the Yeso appear





to be dolomitic and silty. Outcrops of the Yeso Formation may locally contain HC limestone. In central New Mexico, the Yeso is overlain by the Glorieta Sandstone and it in turn by the San Andres Limestone. In south-central New Mexico, however, the Yeso grades upward into the San Andres Limestone. In places, several thin, lenticular, arenaceous beds in the lower San Andres are called the Glorieta or Hondo Sandstone Member.

The San Andres Limestone and uppermost beds of the Yeso crop out over extensive areas in the central, south-central, and southeastern parts of the state. The San Andres is the surface bedrock of Chupadera and Jumanes Mesas, the higher mesas east of Socorro, and on the southeast slope of the Los Pinos Mountains; the wide plateau (on the west edge of the High Plains) extending south from near Vaughn onto the east slopes of the Jicarilla, Capitan, White, and Sacramento Mountains; and much of the Otero Mesa—western Guadalupe Mountains area of southeastern Otero County. The San Andres Limestone caps dip-slope cuestas or hogback ridges in or bordering the Zuni, Nacimiento, Sandia, San Andres, Fra Cristobal, and Caballo Mountains, Lucero Mesa, Sierra Cuchillo, and the Phillips Hills. This unit crops out on the Glorieta Mesa escarpment and is present in small outcrop patches along Nogal Canyon in the volcanic San Mateo Mountains and on the south side of Horse Mountain amid the volcanic rocks of the Datil Plateau.

Descriptions of the carbonate beds of the San Andres Limestone indicate that most are dolomitic limestone or magnesium limestone (i.e. more than 5% magnesium carbonate). Beds quarried near Gallinas in central New Mexico, for example, have 20.2% magnesium oxide, 32.20% lime, and 3.26% silica (Vincent C. Kelley, written comm., 1957). In the central Guadalupe Mountains, Boyd (1958, p. 24) reported that samples typical of the San Andres Formation contain 0.5-1.1% SiO<sub>2</sub>, 40.6-45.7% MgCO<sub>3</sub>, and 53.1-58.8% CaCO<sub>3</sub> (nearly pure dolomites!). In contrast, samples from the type section of the San Andres Limestone, in Rhodes Canyon of the San Andres Mountains, gave analyses (Kottlowski, 1957) high in SiO<sub>2</sub> (13.2%) quartz sand and silt for the basal 95 ft of dolomitic limestones, but an average CaO content of 53.5% for the overlying 220 ft of relatively pure limestone containing insoluble residue 1.3%. On the other hand, the upper 255 ft of the formation contain 20.3-28.7% MgCO<sub>3</sub>. On the eastern slopes of the Sacramento Mountains and in oil tests drilled in that area, the lower part of the San Andres Limestone is reported as chiefly limestone, whereas the upper beds are mainly dolomite. Extensive sampling of the widespread San Andres Limestone outcrops should locate some HC limestones in places where they could be quarried economically.

Northward from the type section (Lee and Girty, 1909; Needham and Bates, 1943; Kottlowski et al., 1956), the San Andres Limestone thins from 600 to 750 ft in the northern San Andres Mountains to 110 ft in the southeastern Zuni Mountains (Fig. 2) and 15 ft on northern Glorieta Mesa. Interbeds of gypsum are exposed in such areas as Mesa del Oro (Jicha, 1958), Lucero Mesa (Kelley and Wood, 1946), and southeast Chupadera Mesa (Wilpolt and Wanek, 1952), suggesting deposition in nearshore lagoonal evaporite basins. Toward the southeast, the San Andres Limestone thickens in the Guadalupe Mountains to about 1,200 ft (Hayes, 1964; Boyd, 1958). Triassic or younger strata overlie eroded parts of the San Andres Limestone except in the eastern part of the state, where

the Guadalupian Bernal Formation or Artesia Group rests on the San Andres.

The interbedded red beds, gypsum, and dolomitic rocks of the Artesia Group and Bernal Formation crop out along the Pecos River Valley from Carlsbad northward, and in the Guadalupe Mountains. The carbonate beds are thin, lenticular, impure, and dolomitic. Correlative basinal beds of the Cherry Canyon and Bell Canyon Formations crop out in the state only along the Texas state line in the southern Guadalupe Mountains. The limestone members of these formations are locally as much as 100 ft thick. The carbonate rocks of the Cherry Canyon Formation are impure or dolomitic (Newell et al., 1953); the Rader Limestone and Lamar Limestone Members of the Bell Canyon Formation, however, include HC limestones (Kottlowski, 1962) that crop out on the southeast side of the Guadalupe Mountains. The basinal Yeso equivalent, the Bone Spring Limestone, crops out in the Brokeoff Mountains of the west part of the Guadalupe Mountains, a relatively inaccessible area. Analyses of the upper part of the Victorio Peak Limestone show that it is a HC limestone.

The massive Capitan Limestone reef crops out along the southeast Guadalupe Mountains escarpment and is 1,500-2,000 ft thick if measured vertically without regard to the dip of the reef-flank beds. According to Newell et al. (1953), this limestone is mainly unstratified calcitic, whereas the bordering reef-talus beds contain high percentages of dolomite. Newell et al. listed 11 analyses of the Capitan reef rock that average 98.2% CaCO<sub>3</sub>, 1.3% MgCO<sub>3</sub>, and 0.4% SiO<sub>2</sub>. The reef appears to be a huge mass of HC limestone that is near gas fields, a railroad, and highways. Much of the outcrop area is within the Carlsbad Caverns National Park, but the outcrop belt extends for about 10 mi northeast of the park and from the park southwestward to the Texas state line. cursory sampling of the Capitan Limestone suggests, however, that the limestone and dolomite facies are complexly mingled. Whereas most of the reef-flank beds appear be dolomitic, or at least magnesium-rich, some of the reef-core beds also contain appreciable amounts of MgCO<sub>3</sub>. A chip-channel sample (Kottlowski, 1962) of the reef core in Dark Canyon yielded 16% MgCO<sub>3</sub>. The core appears to be dolomitic and siliceous where the reef-core facies is overlain by sandstone tongues of the Yates and Tansill Formations as along North Slaughter Canyon. Along parts of McKittrick, Rattlesnake, and West Slaughter Canyons, the reef-flank beds, especially the more massive ones, appear to be chiefly limestone, as determined by dilute HCl and by specific-gravity tests in heavy liquids.

The Ochoan Castile and Rustler Formations crop out above the Guadalupian rocks in the Delaware Basin, forming low hills between the valleys of the Black River and the Pecos River south of Carlsbad. The Rustler Formation is composed of dolomite, gypsum, and siltstone, whereas the underlying Castile Formation consists of gypsum, interlaminated gypsum and limestone, and some thin beds of limestone. In the subsurface, both formations include much anhydrite and some halite. Oddly, an analysis of basal limestone from the Castile Formation, as given by King (1948), shows a HC limestone containing 96.63% CaCO<sub>3</sub>. Most of the Castile limestones are too thin and too intimately interlaminated with gypsum to be of commercial use.

In the southwest corner of New Mexico, Permian rocks younger than the Hueco Formation crop out in the Big Hatchet, Peloncillo, and Animas Mountains. The section,

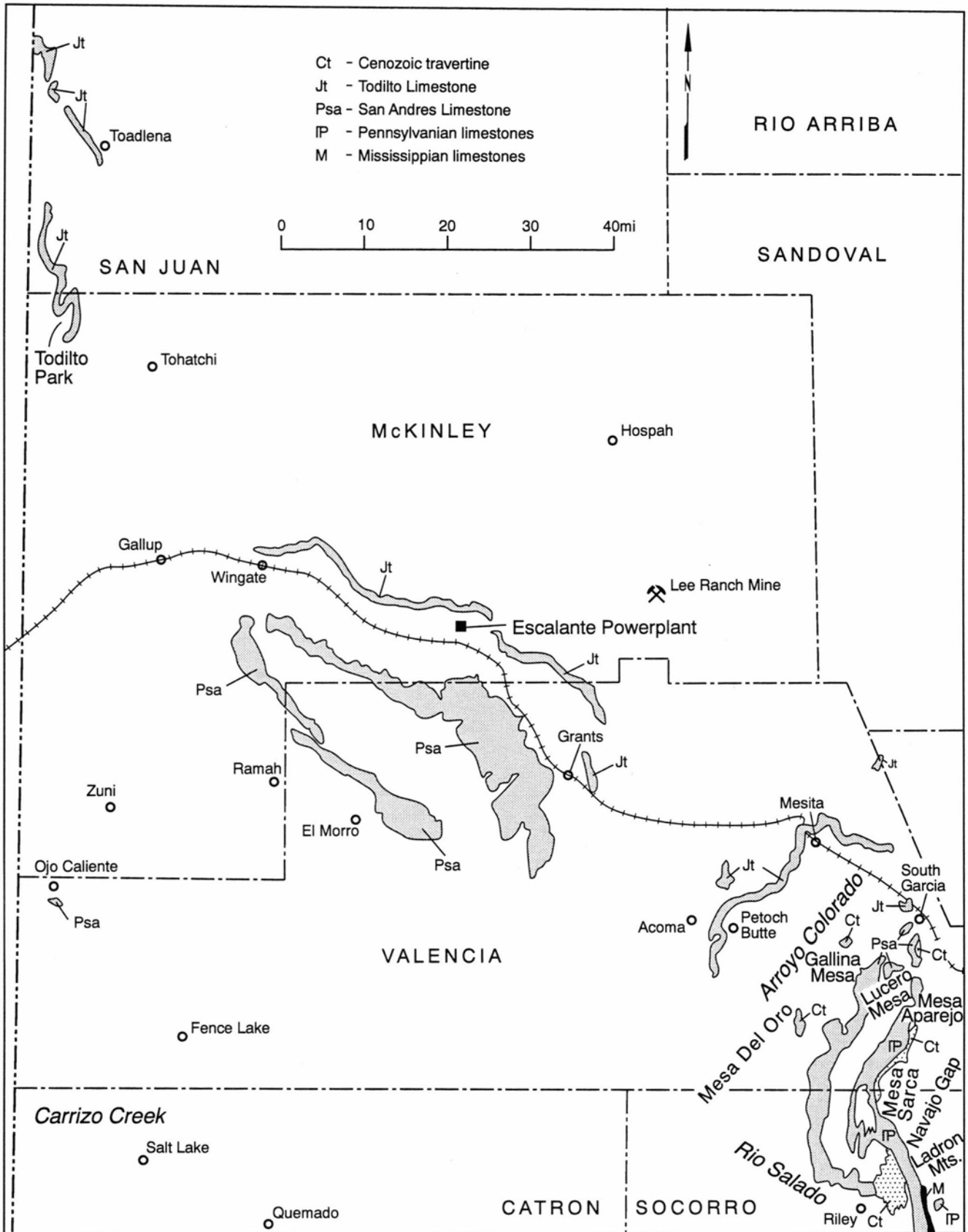

FIGURE 2—Map of northwestern New Mexico showing limestone outcrops (modified from Kottlowski, 1962, fig. 2).

described in detail by Zeller (1958), consists of (ascending) the Horquilla Limestone (of Pennsylvanian and Permian ages), Earp red beds, Colina Limestone, Epitaph Dolomite, Scherrer Sandstone, and Concha Limestone. Fusulinids date the upper Horquilla as Wolfcampian and the Concha Limestone as Leonardian. Yochelson (1956) identified Wolfcampian gastropods in the Colina Limestone from southeastern Arizona; the upper Horquilla Limestone, Earp red beds, and Colina Limestone appear to be a sequence similar to that in the Robledo Mountains (Kottlowski, 1960), where the Hueco Limestone includes a tongue of the Abo red beds. Both the Horquilla and Colina Limestones probably contain HC limestone beds but crop out in relatively inaccessible areas. A chip-channel sample from the Colina Limestone in the Peloncillo Mountains (Kottlowski, 1962) had large amounts of  $\text{SiO}_2$  and  $\text{MgCO}_3$ , but the sample was collected in a metamorphosed zone near a granitic body.

The Epitaph Dolomite includes gypsum and siltstone interbeds and may be a southwestern correlative of the Yeso and Bone Spring Formations; no appreciable amount of HC limestone is known from the Epitaph Dolomite. Likewise, the Concha Limestone appears, from the scant data available, to be too cherty and too dolomitic to contain high-calcium limestones.

### Mesozoic limestones

Limestones in Triassic rocks are limited to thin, lenticular, arenaceous to conglomeratic limy beds in the Chinle and Moenkopi Formations of northwestern New Mexico and the Dockum Group and Chinle Formation in the eastern part of the state.

In Jurassic strata, limestones are found in the Todilto Formation in northern New Mexico. Where typically developed, this formation consists of a lower limestone and an upper gypsum. The limestone, locally as much as 40 ft thick, is dark, laminated, thin- to massive-bedded, fetid, and contains laminae of gypsum near the top. Near the western edge of limestone deposition, in Todilto Park close to the New Mexico-Arizona border, the limestone grades laterally from a 4.6 ft thick limestone bed into limy sandstone and siltstone. North of Todilto Park near Beautiful Mountain, Allen and Balk (1954) noted an extensive mesa capped by 7-14 ft of Todilto limestone and estimated the reserves at 36 million st. These samples average 12.27%  $\text{SiO}_2$ . Allen and Balk believed the silica to be present as an arenaceous laminate in the lower one foot of the limestone. They suggested that if this lower one foot were discarded, the upper beds would be a HC limestone averaging 97.5% calcium carbonate.

Limestone of the Todilto Formation crops out along the northern edge of the Zuni Mountains from near Wingate to east of Grants. The limestone is 7-30 ft thick in this area (average thickness of about 14 ft) and has numerous laminae of sandstone, siltstone, and gypsum, as well as pods of uranium ore. Farther to the southeast, the limestone crops out along the north valley wall of Rio San Jose from near Mesita to north of Suwanee and in several isolated outcrops on the flanks of Mesa Redonda and Lucero Mesa. Thicknesses range from 5 to 16 ft. Similar thicknesses are northeast of Acoma.

Along the north wall of the broad valley of Arroyo Colorado, limestone of the Todilto Formation is thick and caps extensive benches extending from Mesita southeast to Petocho Butte, which is near its southwest wedged-out edge. Silver (1948) reported local thicknesses of 40 ft. A

chip-channel sample contained about 94.3%  $\text{CaCO}_3$ . Selective mining may yield a HC limestone.

East of the Rio Grande Valley, small patches and more extensive outcrops of the Todilto Formation are present northeast and east of the Sandia Mountains, near Lamy and Rosario Siding, and south of Galisteo. The limestone member is thin (3-8 ft thick) and impure. Steeply dipping beds of the Todilto crop out along the west side of Sierra Nacimiento south of Cuba to White Mesa near San Ysidro; here the limestone member, a thin-bedded shaly unit, is 6-12 ft thick and is overlain by interlaminated limestone and gypsum that grade up into the thick, massive gypsum member (Weber and Kottlowski, 1959). The Todilto is exposed north of Gallina in a northward structural extension of the hogback ridges near Cuba as well as to the east along the canyon of Rio Chama and two of its tributaries, Rio Puerco and El Rito. Outcrops of the Todilto Formation encircle Mesa Prieta in the Rio Chama area; the limestone member is lenticular, ranges from 1 to 18 ft in thickness, and consists of lower dark shale grading upward from thin-bedded gray limestone into massive gray limestone and in turn up into a gypsum member. Typically, the Todilto caps benches above cliffs of the Entrada Sandstone and below slopes cut in the Morrison Formation.

The Todilto Formation crops out in the hogback ridges along the southeast edge of the Sangre de Cristo Mountains near Las Vegas, but is thin. On the south edge of Louisiana Mesa near the west border of Quay County east of Ima (sec. 18 T8N R27E), the eastern pinchout of the limestone member borders the valley of Alamogordo Creek. The limestone is a 2-10 ft thick, thinly laminated, platy to fissile bed containing paper-thin laminae of siltstone and gypsum. Surprisingly, however, a channel sample shows almost 95%  $\text{CaCO}_3$  and only slightly more than 1%  $\text{SiO}_2$ . The Todilto crops out as a ledge, capping the soft, brown to light-gray Entrada Sandstone, and is overlain by the slope-forming shales and sandstones of the Morrison Formation.

Cretaceous strata in New Mexico change abruptly from sandstone-shale-coal, chiefly of Late Cretaceous age, in northern and central areas to marine limestones, cobble conglomerates, and reddish clastic rocks of Early Cretaceous age in southwestern areas. Limy beds above the Dakota Sandstone are in the Mancos Shale, Mesaverde Group, and Lewis Shale in northwestern New Mexico, the Mancos Shale in central New Mexico, and the Graneros Shale, Greenhorn Limestone, Carlile Shale, Niobrara Formation, and Pierre Shale in northeastern New Mexico. These formations tend to contain more and thicker limestones from the west to the northeast.

Along the west edge of the San Juan Basin, limy beds in the Cretaceous section are thin, argillaceous limestone lenses or concretionary strata in the lower part of the Mancos Shale or in the Lewis Shale (Beaumont, 1954, 1955; Allen and Balk, 1954). In the Gallup-Zuni Basin, a 10 ft thick bed of fossiliferous impure limestone occurs near the base of the Mancos. Eastward into the Mount Taylor region and to the southeast edge of the San Juan Basin, the limy beds are only calcareous, fossiliferous sandstone and zones of limestone concretions. Along the northeast edge of the San Juan Basin and in the eastward adjoining Chama basin, equivalents of the Graneros, Greenhorn, Carlile, and Niobrara are recognized (Dane, 1948). The Greenhorn Limestone Member of the Mancos Shale consists of interbedded, gray, dense limestone and dark-gray

calcareous shale; the limestone beds are as much as 2.5 ft thick (Dane, 1960) and are described as a limonitic *Globigerina* biomicrite by Muehlberger et al. (1960). Dane (1960) also noted some thin, gray, shaly limestones in the Niobrara calcareous shale member. None of the Cretaceous limestones of northwestern New Mexico are HC limestone. Burchard (1913) reported a lime kiln active near Kirtland; limy lenses in the Lewis Shale and coquina oyster beds at the top of the Pictured Cliffs Sandstone were quarried for this operation.

In northeast New Mexico, limestones occur as thin, impure beds in the Graneros, Carlile, and Pierre Shales, and in the Greenhorn Limestone and Fort Hays Limestone.

Scattered areas of Cretaceous rocks crop out in southern Santa Fe County and the adjoining eastern parts of Sandoval and Bernalillo Counties; however, the Greenhorn Limestone consists of limestones (in beds 6-12 inches thick) interbedded with shale, and the Niobrara Formation appears to be comprised entirely of clastic rocks. Similarly, only thin impure limestones are found in the Cretaceous of the Carthage coal field (Wilpolt and Wanek, 1952), Caballo Mountains (Kelley and Silver, 1952), southern San Andres Mountains (Kottlowski et al., 1956), Cooks Range (Jicha, 1954), and Silver City area. Near the Capitan coal field in south-central Lincoln County, on the east side of the Sierra Blanca volcanic complex, a 60 ft thick sequence of dark-gray limestone is in the lower part of the Mancos Shale. Shale interbeds make up much of the sequence, and the limestone beds are impure.

Cretaceous strata near the border with Mexico include thick fossiliferous limestones, chiefly of Early Cretaceous age. These limestones, and interbedded clastic units such as limestone-cobble conglomerate, sandstone, and tuftuff-breccia, range from a hundred to thousands of feet in thickness in the East Potrillo (Bowers, 1960), Big Hatchet (Zeller, 1965), Little Hatchet, Animas, Peloncillo and Victorio Mountains, in small outcrop areas on Cerro del Muleros, on the west edge of the West Potrillo Mountains, and in faulted areas of Sierra Rica and the Apache Hills. Large masses of relatively HC Cretaceous limestone are in remote localities, except the somewhat marly beds that encircle Cerro de Muleros near El Paso. The limestone used by the Southwestern Portland Cement Company from quarries near Cerro del Muleros is almost HC limestone, being barely too high in  $\text{SiO}_2$  (3.2%) and with considerable  $\text{MgCO}_3$  (2.1%). Higher, thick-bedded limestone from the Buda Limestone, collected on the outskirts of Sunland Park Village, is similar in composition with somewhat too high  $\text{SiO}_2$  (3.7%) and clay (alumina 0.7%).

### Cenozoic limestones

Most of the Cenozoic sedimentary strata of New Mexico are clastic rocks that are highly calcareous because of their derivation, in part, from pre-Cenozoic limestones. The calcareous rocks of Cenozoic age are classified as follows: (1) fresh-water lacustrine limestones, (2) spring deposits, calcareous tufa, and travertine, and (3) caliche blankets. With few exceptions, these nonmarine calcium-carbonate deposits do not qualify as HC limestone because of their high content of clay and noncarbonate sand and silt. Impure limestones are found in some of the Tertiary sedimentary units. Travertine and calcareous tufa spring deposits are extensive in the state—some of the larger deposits are those around Lucero Mesa and Mesa del Oro. The banded porous travertine of the northeast Lucero

Mesa area has been quarried as travertine "marble" and makes an attractive ornamental stone (Austin and Barker, 1990). Jicha (1956) described similar spring deposits from the Mesa del Oro area and gave an analysis showing the  $\text{CaCO}_3$  content as 96.5%. The three samples that he combined for the analyses yielded insoluble residues of 0.3, 1.3, and 3.0%.

The travertine deposits on the northeast end of Lucero Mesa near South Garcia station were sampled extensively; only a few samples have less than 10% insoluble residues. The higher-grade travertines are in thin, lenticular beds. A representative chip-channel sample of a 17 ft thick "bed" (Kottlowski, 1962) shows about 85%  $\text{CaCO}_3$ , 11%  $\text{SiO}_2$  and  $\text{Al}_2\text{O}_3$ , and almost 1% combined iron oxide and sulfur.

West of the Ladron Mountains, and overlooking Rio Salado to the south, massive-bedded and laminated Riley travertine (Barker, 1983) caps the Santa Fe Group and older beds, occurring along a north-south belt about 3 mi wide and 9 mi long, underlying about 20 mi<sup>2</sup> of upland plains. A chip-channel sample of the laminated limestone shows 99%  $\text{CaCO}_3$ . Grab samples from other localities contain scattered to abundant grains of quartz silt.

The banded-travertine deposits described by Jicha (1956) at the north tip of Mesa del Oro are in a rather anomalous situation for spring deposits. They cap the easily eroded Triassic red beds high above valleys carved in these red beds, and locally are overlain by Quaternary basalt flows. Apparently the travertine is not related to faults. Being erosional remnants, their original extent is not known, but they form continuous north-south belt about 5 mi long and 2 mi wide. About 7-10 mi to the northeast of Mesa del Oro, and 1-5 mi west of Lucero Mesa, high, isolated buttes are capped by areally small remnants of similar travertine. If these deposits were a single continuous sheet during the late Tertiary, they covered an area of at least 35 mi<sup>2</sup> and may be a travertine playa lake deposit or a relatively pure caliche capping an old erosional surface.

Several lenticular algal travertines, locally in lenses as much as 40 ft thick, are present in the Tertiary Palm Park Formation of the southwestern Caballo Mountains (Fitzmaurice, 1990). In the valleys of Apache and Green Creeks, the Love Ranch Formation is unconformable on Paleozoic rocks and consists of interbedded red siltstones and pebble to boulder conglomerates with clasts of Precambrian and Paleozoic rocks. The overlying Palm Park Formation consists of grayish-red tuffaceous siltstone, purple andesite conglomerate, and brown volcanoclastic sandstone with the conspicuous travertine lenses in the upper middle part of the sequence. The mound-like masses of algal fresh-water limestone appear to be high in calcium, with one chip-channel sample of a 40 ft thick mass yielding 97%  $\text{CaCO}_3$ .

Caliche, widely used for road metal in the intermontane plateaus and the High Plains of New Mexico, is the only monolithologic calcium-carbonate rock inexpensively available in that part of the state. Finely banded (algal-like) and pisolitic travertine lenses are found in many localities in the caliche (Bretz and Herberg, 1949), especially in the "caprock" of the High Plains in eastern New Mexico. In most areas the relatively pure "limestone" is thin (1-2 ft) and lenticular. Bretz and Horberg (1949) reported an average of only 3% insoluble residues from 12 samples of the caprock caliche. Samples of the top 21/2 zones (banded caprock, brecciated caprock, and

upper chalky concretionary caliche) from three widely separated localities in southeastern New Mexico have an average insoluble residue of more than 31%. Selected fragments of the upper caprock may contain only 3-10% insoluble residues, but any appreciable thickness or lateral mass of the caprock appears to be high in siliceous impurities.

Thick (>2 ft), extensive, and relatively HC caliche appears confined, except for localized deposits, to surfaces bordering the valley of the Rio Grande and its tributaries and to the Llano Estacado of eastern New Mexico and its isolated western remnants. The caliche of eastern New Mexico is more important economically, as it provides road metal and aggregate.

**San Juan Mountains, southwestern Colorado**

The San Juan Mountains (Fig. 3) are a dissected dome more than 100 mi across. The mountains are primarily Tertiary volcanic rocks, but Paleozoic rocks are exposed in the western and northern parts. The Paleozoic limestone outcrops bordering the Animas River are 50-70 mi northeast of the Four Corners powerplants. The Cambrian

Ignacio Quartzite (100-150 ft thick) rest unconformably on Proterozoic rocks. The Devonian Elbert Formation (20-70 ft thick) is composed of calcareous shales and thin sandy limestones with salt casts. The Devonian Ouray Limestone (100-200 ft thick) is a relatively pure, massive limestone. The Mississippian Leadville Limestone (100-150 ft thick) is composed of crinoidal and dolomitic limestones.

The Pennsylvanian Hermosa Formation is a 2,000 ft thick series of alternating limestones, shales, siltstones, and conglomerates. The limestones are generally massive, of marine origin, and commonly contain bituminous matter. Limestone beds range from 10 to 50 ft in thickness.

Although the limestones along the Animas River north of Durango are the closest carbonate rocks to the two powerplants west of Farmington, it is doubtful that they could be utilized because the outcrop areas are environmentally sensitive forest lands, the highway for transportation goes through the scenic tourist city of Durango, and in many places large-truck traffic would make the highway dangerous.

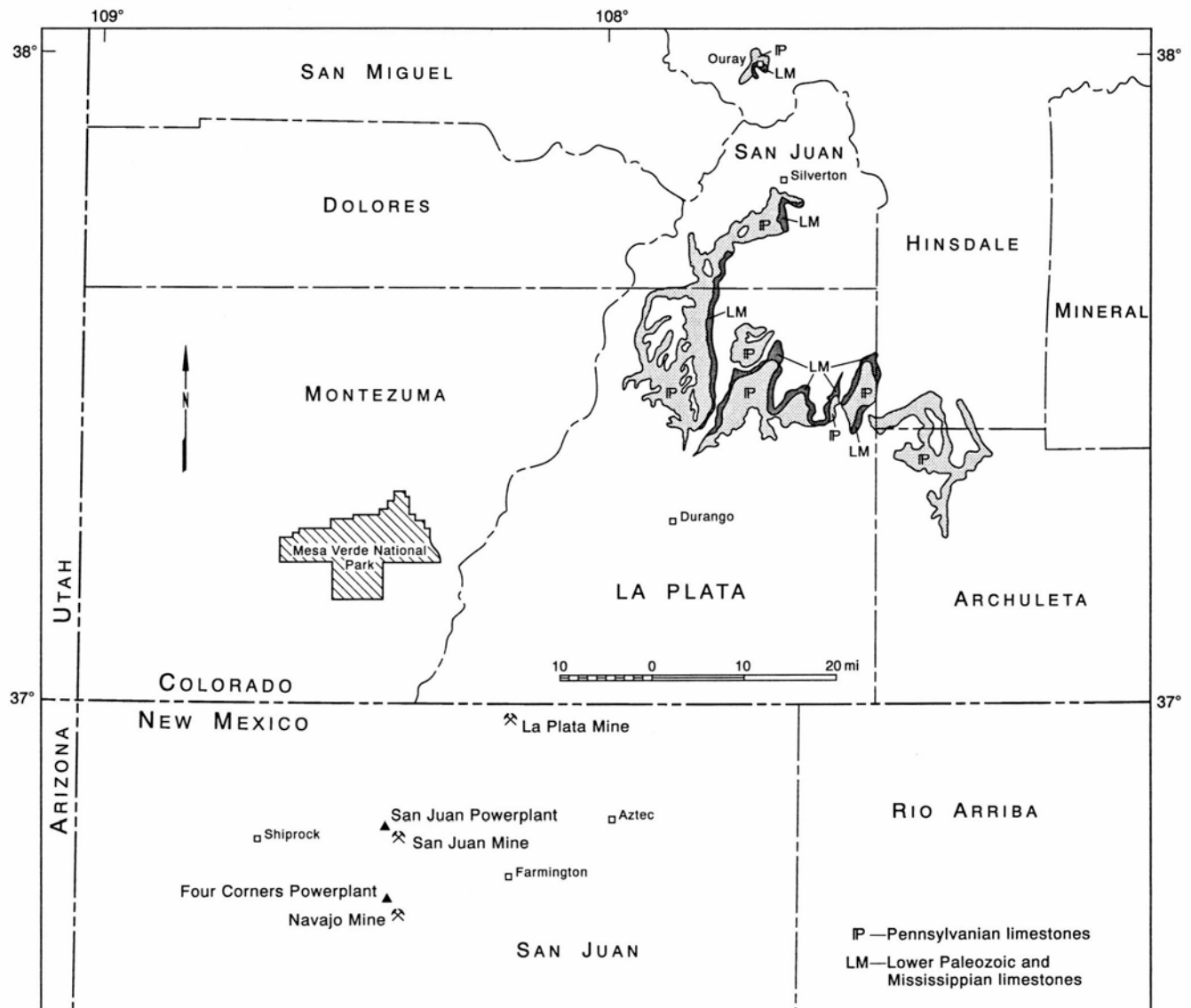

FIGURE 3—Limestone outcrops, coal-fired powerplants, and open-pit coal mines in northwestern New Mexico and southwestern Colorado (compiled by Kottlowski and Armstrong for this report).

## Conclusions

New Mexico has ample amounts of HC limestone but no large quantities near the two present-day powerplants west of Farmington. The Escalante powerplant in west-central New Mexico does use Permian limestones for its flue-gas desulfurization.

## Acknowledgments

The writers thank George S. Austin, James M. Barker, Gretchen K. Hoffman, and Jiri Zidek, New Mexico Bureau of Mines and Mineral Resources, Chester Wrucke, U.S. Geological Survey, and Donald D. Carr, Indiana Geological Survey, for helpful comments, data, and corrections. Terry Telles typed the manuscript and Becky Titus drafted the figures.

## References

- Allen, J. E., and Balk, R., 1954, Mineral resources of the Navajo reservation in New Mexico: New Mexico Bureau of Mines and Mineral Resources, Bulletin 36, 192 pp.
- Armstrong, A. K., 1955, Preliminary observations on the Mississippian System of northern New Mexico: New Mexico Bureau of Mines and Mineral Resources, Circular 39, 42 pp.
- Armstrong, A. K., 1958, The Mississippian of west-central New Mexico: New Mexico Bureau of Mines and Mineral Resources, Memoir 5, 34 pp.
- Armstrong, A. K., 1962, Stratigraphy and paleontology of the Mississippian System in southwestern New Mexico and adjacent southeastern Arizona: New Mexico Bureau of Mines and Mineral Resources, Memoir 8, 99 pp.
- Armstrong, A. K., 1978, The Mississippian System of southwestern New Mexico and southeastern Arizona: New Mexico Geological Society, Guidebook 29, pp. 183-192.
- Armstrong, A. K., Kottowski, F. E., Steward, W. J., Mamet, B. L., Baltz, E. H., Siemers, W. T., and Thompson, S., III, 1979., The Mississippian and Pennsylvanian (Carboniferous) Systems in the United States-New Mexico: U.S. Geological Survey, Professional Paper 1110-W, pp. 1-27.
- Armstrong, A. K., and Mamet, B. L., 1988: Mississippian biostratigraphy, facies, and microfossils, Pedregosa Basin, southeastern Arizona and southwestern New Mexico: U.S. Geological Survey, Bulletin 1826, 40 pp.
- Austin, G. S., and Barker, J. M., 1990, Commercial travertine in New Mexico: New Mexico Geology, v. 12, pp. 49-58.
- Bachman, G. O., 1975, Paleotectonic investigation of the Pennsylvanian System in the United States-New Mexico: U.S. Geological Survey, Professional Paper 853, Part 1, pp. 233-243.
- Baltz, E. H., and Reed, C. B., 1960, Rocks of Mississippian and probable Devonian age in Sangre de Cristo Mountains, New Mexico: American Association of Petroleum Geologists Bulletin, v. 44, pp. 1749-1774.
- Barker, J. M., 1983, Preliminary investigation of the origin of the Riley travertine, Socorro Co., New Mexico: New Mexico Geological Society, Guidebook 34, pp. 269-276.
- Beaumont, E. C., 1954, Geology of the Beautiful Mountain anticline, San Juan County, New Mexico: U.S. Geological Survey, Oil and Gas Investigations Map OM 147, scale 1:48,000.
- Beaumont, E. C., 1955, Preliminary geologic map of the Ship Rock and Hogback quadrangles, San Juan County, New Mexico: U. S. Geological Survey, Coal Investigations Map C-29 scale approx. 1.2 inches to 1 mi.
- Bowers, W. E., 1960, Geology of the East Potrillo Hills, Dona Ana County, New Mexico: Unpublished MS Thesis, University of New Mexico, 66 pp.
- Boyd, D. W., 1958, Permian sedimentary facies, central Guadalupe Mountains, New Mexico: New Mexico Bureau of Mines and Mineral Resources, Bulletin 49, 100 pp.
- Bretz, J. H., and Horberg, L., 1949, Caliche in southeastern New Mexico: Journal of Geology, v. 57, pp. 491-511.
- Burchard, E. F., 1913, Stone; *in* Mineral resources of the United States, for 1912, Part II, Nonmetals: U.S. Geological Survey, pp. 267-298.
- Dane, C. H., 1948, Geologic map of eastern San Juan Basin, Rio Arriba County, New Mexico: U.S. Geological Survey, Oil and Gas Preliminary Map No. 78 scale: approx. 1 inch= 1 mile.
- Dane, C. H. 1960, The Dakota Sandstone and Mancos Shale of the eastern side of the San Juan Basin, New Mexico: New Mexico Geological Society, Guidebook 11, pp. 63-74.
- Ellison, W., and Kuntze, R. A., 1993, Expanding of markets for gypsum products: Society for Mining, Metallurgy, and Exploration, Preprint 93-164 for Annual Meeting in Reno, Nevada, 8 pp.
- Fitzmaurice, S., P., 1990, The petrography, geochemistry, and depositional environment of travertines of the Palm Park Formation (Eocene), Caballo Mountains, New Mexico: Unpublished MS thesis, University of Houston, 316 pp.
- Harbour, R. L., 1960, Road log, Las Cruces to Vinton Canyon and Anthony Gap: Roswell Geological Society Guidebook to Northern Franklin and Southern San Andres Mountains, pp. 11-33.
- Hayes, P. T., 1964, Geology of the Guadalupe Mountains, New Mexico: U.S. Geological Survey, Professional Paper 466, 84 pp.
- Jicha, H. L., 1954, Geology and mineral deposits of Lake Valley quadrangle, New Mexico: New Mexico Bureau of Mines and Mineral Resources, Bulletin 37, 93 pp.
- Jicha, H. L., 1956, A deposit of high-calcium lime rock in Valencia County, New Mexico: New Mexico Bureau of Mines and Mineral Resources, Circular 36, 5 pp.
- Jicha, H. L., 1958, Geology and Mineral resources of Mesa del Oro quadrangle, New Mexico: New Mexico Bureau of Mines and Mineral Resources, Bulletin 56, 67 pp.
- Kelley, V. C., and Silver, C., 1952, Geology of the Caballo Mountains: University of New Mexico Publications, Geology Series, No. 4, 286 pp.
- Kelley, V. C. and Wood, G. H., 1946, Lucero uplift, Valencia, Socorro, and Bernalillo Counties, New Mexico: U.S. Geological Survey, Oil and Gas Preliminary Map 47 scale approx. 1:63,360.
- King, P. B., 1948, Geology of the southern Guadalupe Mountains, Texas: U.S. Geological Survey, Professional Paper 215, 183 pp.
- Kottowski, F. E., 1957, High-purity dolomite deposits of south-central New Mexico: New Mexico Bureau of Mines and Mineral Resources, Circular 47, 43 pp.
- Kottowski, F. E., 1960, Summary of Pennsylvanian sections in southwestern New Mexico and southeastern Arizona: New Mexico Bureau of Mines and Mineral Resources, Bulletin 66, 187 pp.
- Kottowski, F. E., 1962, Reconnaissance of commercial high-calcium limestones in New Mexico: New Mexico Bureau of Mines and Mineral Resources, Circular 60, 77 pp.
- Kottowski, F. E., Flower, R. H., Thompson, M. L., and Foster, R. W., 1956, Stratigraphic studies of the San Andres Mountains, New Mexico: New Mexico Bureau of Mines and Mineral Resources, Memoir 1, 132 pp.
- Lee, W. T., and Girty, G. H., 1909, The Manzano Group of the Rio Grande Valley, New Mexico: U.S. Geological Survey, Bulletin 389, 141 pp.
- Meyer, R. F., 1966, Geology of Pennsylvanian and Wolfcampian rocks in southeast New Mexico: New Mexico Bureau of Mines and Mineral Resources, Memoir 17, 123 pp.
- Muehlberger, W. R., Adams, G. E., Longgood, T. E., and St. John, B. E., 1960, Stratigraphy of the Chama quadrangle, northern Rio Arriba County, New Mexico: New Mexico Geological Society, Guidebook 11, pp. 93-102.
- Myers, D. A., 1973, The upper Paleozoic Madera Group in the Manzano Mountains, New Mexico: U.S. Geological Survey, Bulletin 1372-F, 13 pp.
- Needham, C. E., and Bates, R. L., 1943, Permian type sections in central New Mexico: Geological Society of America Bulletin, v. 54, pp. 1653-1667.
- Newell, N. D., Fisher, A. G., Whiteman, A. J., Hickox, J. E., and Bradley, J. S., 1953, The Permian reef complex of the



- Guadalupe Mountains, Texas and New Mexico: W. H. Freeman & Co., San Francisco, 236 pp.
- Otte, C., Jr., 1959, Late Pennsylvanian and early Permian stratigraphy of the northern Sacramento Mountains, Otero County, New Mexico: New Mexico Bureau of Mines and Mineral Resources, Bulletin 50, 111 pp.
- Pray, L. C., 1961, Geology of the Sacramento Mountains escarpment, Otero County, New Mexico: New Mexico Bureau of Mines and Mineral Resources, Bulletin 35, 144 pp.
- Read, C. B., and Wood, G. H., 1947, Geologic map and stratigraphic sections of Permian and Pennsylvanian rocks of parts of San Miguel, Santa Fe, Sandoval, Bernalillo, Torrance, and Valencia counties, north-central New Mexico: U.S. Geological Survey, Oil and Gas Preliminary Map 21, scale approx. 1:190,080.
- Siemers, W. T., 1982, New Mexico limestones-Geology, uses, and economic potential of high-calcium limestone: New Mexico Bureau of Mines and Mineral Resources, Circular 182, pp. 39-42.
- Silver, C., 1948, Jurassic overlap in western New Mexico: American Association of Petroleum Geologists Bulletin, v. 32, pp. 68-81.
- Sutherland, P. K., 1963, Paleozoic rocks; *in* Miller, J. P., Montgomery, A., and Southerland, P. K. (eds.), Geology of part of the southern Sangre de Cristo Mountains, New Mexico: New Mexico Bureau of Mines and Mineral Resources, Memoir 11, pp. 22-46.
- Thompson, M. L., 1942, Pennsylvanian System in New Mexico: New Mexico Bureau of Mines and Mineral Resources, Bulletin 17, 90 pp.
- Thompson, M. L., 1954, American Wolfcampian fusulinids: Kansas University Paleontological Contributions, no. 14, Protozoa, article 5, 226 pp.
- Thompson, S., III, and Jacka, A. D., 1981, Pennsylvanian stratigraphy, petrography, and petroleum geology of Big Hatchet Peak section, Hidalgo County, New Mexico: New Mexico Bureau of Mines and Mineral Resources, Circular 176, 125 pp.
- Weber, R. H., and Kottowski, F. E., 1959, Gypsum resources of New Mexico: New Mexico Bureau of Mines and Mineral Resources, Bulletin 68, 68 pp.
- Wilpolt, R. H., and Wanek, A. A., 1952, Geology of the region from Socorro and San Antonio east to Chupadera Mesa, Socorro County, New Mexico: U.S. Geological Survey, Oil and Gas Investigations Map OM 121, scale 1:63,360.
- Wilson, J. E., 1989, Lower and Middle Pennsylvanian strata in the Orogrande and Pedregosa Basins, New Mexico: New Mexico Bureau of Mines and Mineral Resources, Bulletin 124, 16 pp.
- Yochelson, E. L., 1956, Permian Gastropoda of the southwestern United States: American Museum of Natural History and Bulletin, v. 110, article 3, 275 pp.
- Zeller, R. A., Jr., 1958, The geology of the Big Hatchet Peak quadrangle, Hidalgo County, New Mexico: Unpublished PhD dissertation, University of California (Los Angeles), 260 pp.
- Zeller, R. A., Jr., 1965, Stratigraphy of the Big Hatchet Mountains area, New Mexico: New Mexico Bureau of Mines and Mineral Resources, Memoir 16, 128 pp.



# Geology and chemistry of humate deposits in the southern San Juan Basin, New Mexico

Gretchen K. Hoffman<sup>1</sup>, Jeanne Verploegh<sup>2</sup>, and James M. Barker<sup>1</sup>

<sup>1</sup>New Mexico Bureau of Mines & Mineral Resources, New Mexico Tech, 801 Leroy Place, Socorro, New Mexico 87801-4796, USA  
<sup>2</sup>Department of Earth and Environmental Science, New Mexico Tech, 801 Leroy Place, Socorro, New Mexico 87801-4796, USA

**Abstract**—Humate, defined as weathered coal or mudstone rich in humic acid (HA) and fulvic acid (FA), has been mined in New Mexico for 15-20 years, primarily as soil amendments or drilling-mud additives. The New Mexico humate resource is estimated to be 11 Gt, including weathered coal and carbonaceous mudstone. The HA and FA content determines the end-use, therefore a simple and consistent method of measuring organic-acid content was developed. The New Mexico Bureau of Mines and Mineral Resources method is based on repeated alkali leaching and acid precipitation. Precipitates of humate are ached, with mass balance of solids maintained, to correct for material added by precipitation during alkali-acid treatment. Analyses of upper coal member, Cleary Coal Member (Menefee Formation), and Fruitland Formation samples from the southeast San Juan Basin show ashing to be important in accurate analysis of FA content. Ash in the total FA fraction averages 70% compared to 2% in HA. The quantities of FA in weathered coal and carbonaceous mudstone are similar, although HA is significantly higher in the former. As weathering progresses, the FA content of weathered coal increases faster than in carbonaceous mudstone because of the greater total organic component in coal.

## Geología y química de yacimientos humíferos en el sur de la Cuenca de San Juan, Nuevo Mexico

**Resumen**—Humato es carbon alterado o esquisto arcilloso (*muds tone*) rico en los ácidos húmicos (AH) y fúlvico (AF). Desde hace 15-20 años se está explotando este material en Nuevo Mexico, principalmente para uso en mejoramiento de suelos agrícolas o como aditivos en barro de perforación. Entre las dos clases de yacimientos, las reservas en Nuevo Mexico se estiman en unas once mil millones de toneladas. La aplicación que se les da a estas materias primas depende de su contenido proporcional en AH y AF. Es por esta razón que el Servicio de Minas y Recursos Minerales de Nuevo Mexico (*New Mexico Bureau of Mines and Mineral Resources*) ha desarrollado un método cuantitativo simple y reproducible para analizar el contenido de ácidos orgánicos. El análisis consiste en repetida lixiviación alcalina y precipitación ácida, seguida de incineración de los precipitados de humato. Es necesario mantener un balance de masa de los sólidos para poder corregir el resultado por la precipitación de sustancias químicas durante los tratamientos alcalino y ácido. Análisis de muestras procedentes del Miembro Carbonífero Superior y del *Cleary Coal Member*, ambos de la Formación Menefee, así como de la Formación Fruitland en el sureste de la Cuenca demuestran que la incineración es importante para el análisis preciso de AF. Ceniza en la fracción total de AF alcanza un promedio del 70%, comparado con solo un 2% en AH. Las proporciones de AF en carbón alterado y en esquisto bituminoso son similares, pero la abundancia de AH es apreciablemente mayor en aqua. A medida que progresa la alteración el contenido AF del carbon aumenta mas rapido que en los esquistos porque el carbon tiene un contenido mas elevado de materia organica.

### Introduction

Humate occurs in Arkansas, Florida, Louisiana, New York, Michigan, Minnesota, New Mexico, Texas, and Wyoming (Burdick, 1965; Swanson and Ging, 1972) as weathered coal or carbonaceous mudstone, and as weathered lignite (leonardite) in North Dakota and southeastern Saskatchewan (Broughton, 1972). Weathered coal and carbonaceous mudstone, which contain humic acid (HA) and fulvic acid (FA), together form a large potential resource in the San Juan Basin (SJB) of northwestern New Mexico. Our paper utilizes samples from the Chacra Mesa and La Ventana coal fields to develop more accurate analytical methods for quality and resource evaluation (Fig. 1).

Humate has been mined in New Mexico for the past 15-20 years, and is marketed primarily as a soil amend-

ment or drilling-mud additive. Two humate mines operate in the southeastern part of the SJB, with a third under development (Fig. 2). Most of the production has been from the Upper Cretaceous Menefee Formation. Seimers and Wadell (1977) estimated that carbonaceous mudstone constitutes 8-12% and coal comprises 4% of the entire Menefee Formation. In the Chacra Mesa and La Ventana coal fields, conservative estimates of weathered coal resources within 9 m of the surface are 1.1 Gt. The 9 m limit is used as a typical maximum depth for significant weathering of coal; this limit is commonly used in coal-mine planning in the SJB. These data suggest that 2.3-3.4 Gt of carbonaceous mudstone is available in this area for a total regional humate resource of 3.445 Gt. The humate resource for all of New Mexico is estimated to be 11 Gt.

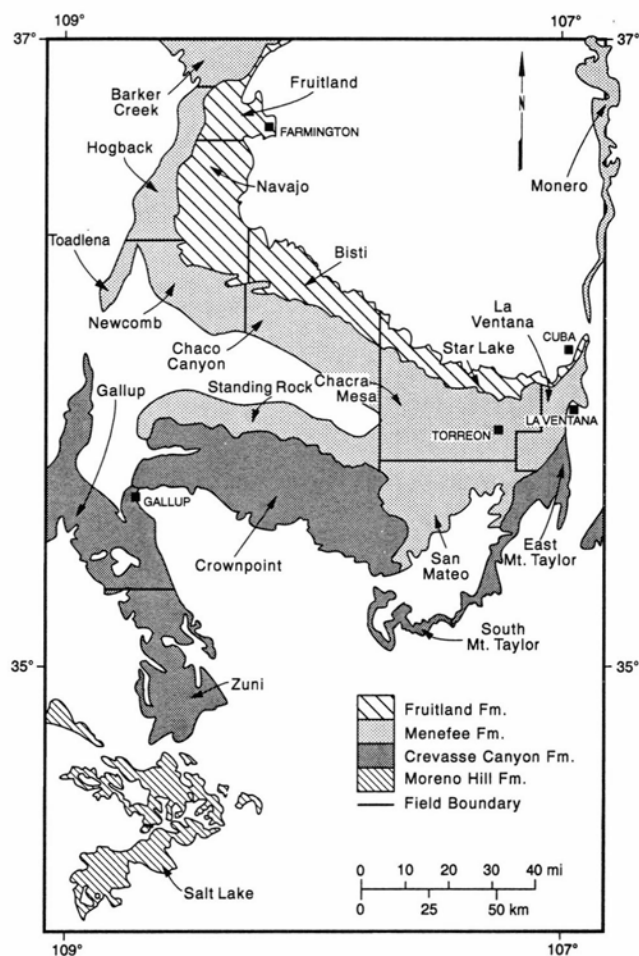

FIGURE 1—Coal fields in the San Juan Basin. Field names in italics, modified from Hoffman et al. (1993).

### Terminology

Humate terminology is confusing, particularly when scientific, mining, and business terms are compared (Table 1; Stevenson, 1982). Humic substances are a naturally occurring mixture of heterogeneous, organic materials that are not easily degraded (Aiken et al., 1985). Humification is the process of forming these substances, generally by decomposition of organic material during

TABLE 1—Total thickness at sample locations and percent weathered coal.

Identification	Thickness in meters	Percentage weathered coal
<b>Clery Coal Member, Menefee Formation—12 samples</b>		
Kmfc-1A-1D Total thickness	0.75	
Total weathered Coal	0.49	65.33
Kmfc-2A-2H Total thickness	1.77	
Total weathered Coal	0.87	49.15
<b>Upper coal member, Menefee Formation—19 samples</b>		
Kmfu-1A-1D Total thickness	3.96	
Total weathered Coal	0.76	19.19
Kmfu-2A-2C Total thickness	1.16	
Total weathered Coal	0.30	25.86
Kmfu-3A-3C Total thickness	0.66	
Total weathered Coal	0.00	0.00
Kmfu-4A-4D Total thickness	4.11	
Total weathered Coal	0.18	4.38
Kmfu-5A-5D Total thickness	2.53	
Total weathered Coal	0.43	17.00

weathering. This decay releases dark-colored humate with a high molecular weight (5,000-50,000) that is partly colloidal and weakly acidic due to HA and FA content (Roybal and Barker, 1987). HA includes additional smaller molecules and is more acidic than chemical HA as derived in the laboratory (Krauskopf, 1967). A typical major-element composition of humate (dry, ash-free) is 50-60% carbon, 30-40% oxygen, 3-5% hydrogen, 1-3% nitrogen, and 1-3% sulfur (Swanson, 1977). Humate in a geologic context, as used herein, is weathered lignite, weathered coal, and carbonaceous mudstone that contain humic substances (primarily HA and FA).

In chemistry, humate is more specifically the salts of HA (Siemers and Wade, 1977). The chemical breakdown of humate into its soluble and insoluble components is also a basis for classification and analysis as shown in Figure 3 (Swift, 1985).

Several complex chemical methods are used to determine the HA, FA, and humin content of these organic colloids, but an easier and more reliable method is needed. Chemists at the New Mexico Bureau of Mines and Mineral Resources (NMBMMR) devised a method to meet these needs (Verploegh and Brandvold, 1990), which includes ashing steps to yield more accurate and precise HA and FA data. Several samples from the Menefee Formation were analyzed using this method to refine humate quality and quantity estimates, and for comparison with previous humate studies in the SJB.

### Area of study

The study area is within the Chacra Mesa and La Ventana coal fields on the southeastern edge of the SJB (Fig. 1). Weathered coal and carbonaceous mudstone sequences crop out in the southeastern part of the SJB, near the villages of Torreon, San Luis, and Cuba (Fig. 2). Samples were taken from both the upper coal and Clery Coal members of the Menefee Formation. Previously collected "fresh" coal cores from this area were used for comparison. Two samples were collected from stockpiles at the Mesa Verde Resources mill. The stockpiles are trucked to Bernalillo from the Star Lake and Pueblo Alto pits, where dominantly weathered coal, with some carbonaceous mudstone, of the Fruitland Formation is mined.

### Geologic setting

#### Structure

The Upper Cretaceous outcrops gently dip 2-5° north-northwest in the Chacra Mesa coal field and in the western part of the La Ventana field. The dip of beds in the eastern La Ventana field, just west of the Nacimiento uplift, increases from 35 to 45° west-northwest to nearly vertical.

#### Stratigraphy

The Menefee Formation is part of the Upper Cretaceous Mesaverde Group deposited in the SIB during a major regression then transgression of the northwest-trending (approximately N55°W) shoreline of an epicontinental sea. From southwest to northeast, the Menefee Formation consists of (1) floodplain and lacustrine deposits, typically lenticular sandstones and shales, and (2) coastal swamp deposits of shale, siltstone, coal, and channel sandstone. Although these broad sedimentary facies are nearly continuous over large areas, individual lithic types, including coal, vary greatly over short lateral distances. The Menefee is underlain (Point Lookout Sandstone) and over-

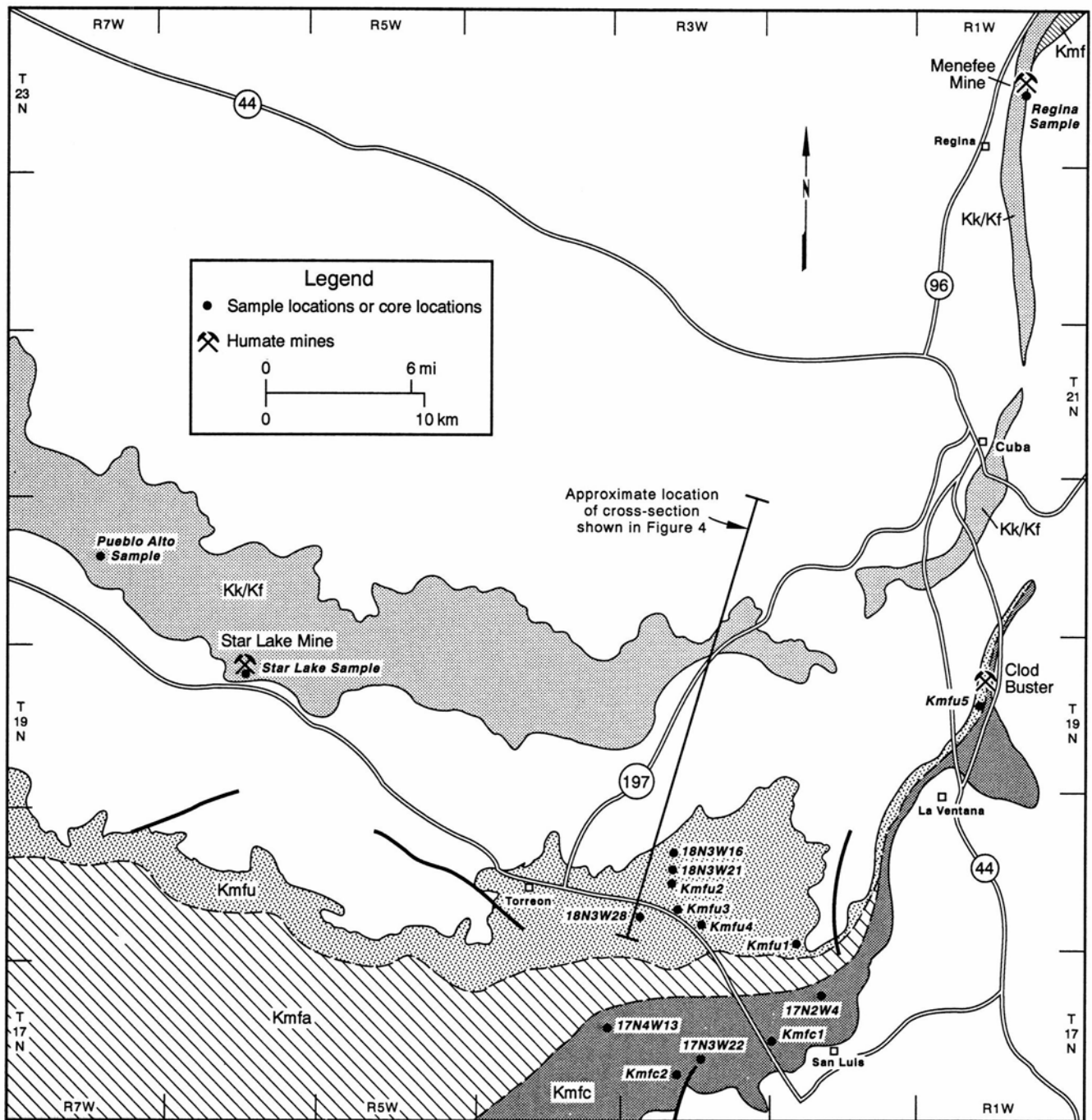

FIGURE 2—Sample locations and humate mines in the southeastern San Juan Basin. (Kk/Kf= Kirtland/Fruitland Formation; Kmfu= Menefee Formation, upper coal member; Kmfa= Menefee Formation, Allison Member; Kmfc= Menefee Formation, Cleary Coal Member; Kmf= Menefee Formation, undifferentiated).

lain (Cliff House Sandstone) by beach and nearshore sediments that include extensive sandstone and lagoonal silt-stone (Beaumont, 1971). Figure 4 is a diagrammatic N15°E-trending cross section, about 29 km long, of this sequence on the eastern edge of the SJB (see Fig. 2 for approximate location).

The Cleary Coal Member of the Menefee Formation is the first 31-61 m of strata above the top of the Point Lookout Sandstone (Beaumont and Hoffman, 1992; fig. 4). This coal-bearing sequence represents the transitional phase between completely marine and completely continental deposits during a Late Cretaceous shoreline regression to the southwest. The Cleary Coal Member contains thick

coals, but in the area sampled coals are relatively thin (0.12-0.36 m) and interbedded with similar thicknesses of carbonaceous mudstone. The sampled Cleary sections contain almost a 1:1 ratio of weathered coal to carbonaceous mudstone, although the entire section is relatively thin (0.75-1.77 m; Table 2).

The upper coal member of the Menefee Formation was deposited at the beginning of the transgression represented by the uppermost 137 m of the Menefee Formation (Beaumont and Hoffman, 1992). In the study area, the upper coal member intertongues with the La Ventana Tongue of the Cliff House Sandstone (Fig. 4), a major stack of barrier-beach sandstones developed during shoreline

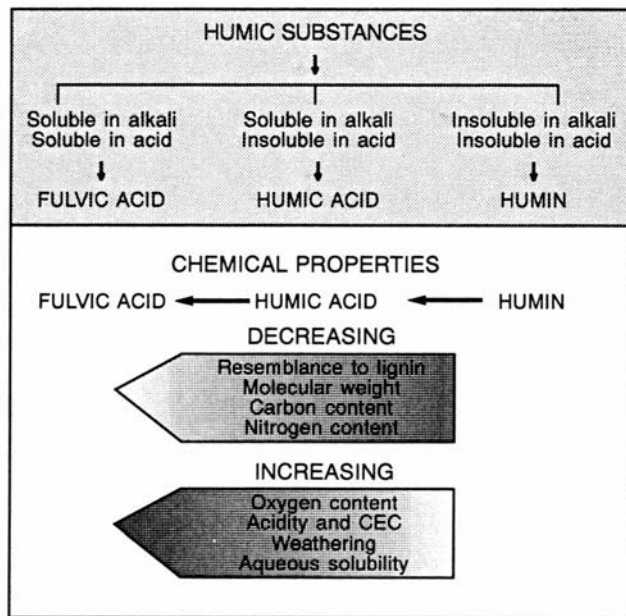

FIGURE 3—Differentiation of humic substances by alkali and acid fractionation and some properties of the resulting fractions (modified from Swift, 1985).

stillstand. This stillstand, with minor oscillations, allowed development of peat swamps parallel to the shoreline and behind the massive barrier sands. Upper coal member samples were taken at outcrops of these marginal peat-swamp deposits. A few thin, weathered coal outcrops (0.3-0.76 m thick) were sampled from the upper coal member, but the majority of samples were carbonaceous mudstones that range from 0.24 to 1.8 m in thickness. Several carbonaceous mudstones sampled are relatively thick (1.5 m) and the total thickness of these coal and carbonaceous mudstone sequences is up to 4.6 m. The upper coal sections contain a large proportion of carbonaceous mudstone with weathered coal constituting as much as 25% of the entire section (Table 2).

The Fruitland Formation, the youngest coal-bearing sequence in the SJB, was deposited behind the barrier-beach Pictured Cliffs Sandstone during the final retreat of the shoreline northeast across the basin. The Fruitland depositional environment is similar to that of the Cleary Coal Member of the Menefee, although Fruitland coals, which tend to be thicker, represent a more stable swamp. Two samples were collected from the Mesa Verde Re

sources stockpiles of mixed lithologies of the Fruitland Formation from the Star Lake and Pueblo Alto pits.

#### Procedure for chemical analysis of humate

Several extraction methods exist for recovery of HA and FA from humic substances (Aiken et al., 1985; Stevenson, 1982). The extraction procedure used in this study consisted of the following steps:

1. Mix, split, and pulverize sample to -60 mesh.
2. Ash 1.0000 g of sample (optional). This is used to determine % ash in untreated sample; see Eq. 1.
3. Weigh 4.0000 g sample into 250 ml centrifuge tube.
4. Add 50 ml of 0.1 N NaOH; stir for 1 hour on magnetic stirrer.
5. Centrifuge for 10 minutes at 10,000 rpm.
6. Decant supernatant into another 250 ml centrifuge tube.
7. Wash pellet, from step 6, with 10 ml of 0.1 N NaOH and centrifuge as above; transfer supernatant to centrifuge tube from step 6.
8. Repeat washing, centrifuging, and transferring four times. Remaining pellet is insoluble humin fraction that can be discarded.
9. *Immediately after centrifuging*, lower supernatant pH to  $1.0 \pm 0.2$  with 6 M HCl.
10. Let stand overnight.
11. Centrifuge to separate HA from FA fractions. HA is the precipitate; FA is left in solution.
12. Wash pellet with pH 1 deionized H<sub>2</sub>O (10 ml; use HCl to lower pH).
13. Weigh two 250 ml beakers; put HA fraction in one, FA in the other.
14. Dry at no higher than 40°C.
15. Weigh beakers plus dried contents.
16. Ash fractions using a modified ASTM coal procedure D3174: 375°C for 2 hours; 750°C for 2 hours.
17. Report as % ash-free HA and % ash-free FA.
18. For samples with high coal content, ash pellet from the NaOH extraction to calculate coal percentage in sample (optional).

The simplest method is basic (NaOH) leach followed by acidic (HCl) precipitation to separate the HA, FA, and humin fractions. HA and FA recovery is then determined gravimetrically. Verploegh and Brandvold (1990) showed that leach solutions of 0.1 N NaOH and leach times of one hour are sufficient to dissolve HA and FA. Further studies at NMBMMR determined that erroneously high HA and FA may be reported due to the weight added to the precipitates by NaOH and HCl salts remain-

TABLE 2—Terms and definitions for humic acid-rich and associated materials. Modified from Roybal and Barker, 1987.

Term	Definition
Carbonaceous claystone/mudstone/shale	Humate to geologists if it contains base-soluble humic acids (Siemers and Wadell, 1977).
Fulvic acid	Fraction of humic substances soluble (in water) under all pH conditions (Aiken et al., 1985).
Humate (singular)	Geologically, a carbonaceous claystone or shale that is rich in humic matter (Siemers and Wadell, 1977).
Humates (plural)	Chemically, salts of humic acids (Siemers and Wadell, 1977).
Humic acid (singular)	Fraction of humic substances not soluble in water under acid conditions (below pH 2), but becomes soluble at greater pH (Aiken et al., 1985)
Humic substances	A general category of naturally occurring, biogenic, heterogenous organic substances that have a high molecular weight and refractory (Aiken et al., 1985).
Humin	Fraction of humic substances not soluble in water at any pH value (Aiken et al., 1985).
Leonardite	Oxidized (weathered) lignite (Kohanowski, 1970; Siemers and Wadell, 1977; Fowkes and Frost, 1960). Sometimes includes weathered subbituminous coal but this is not the preferred term for weathered coal.
Weathered coal	Oxidized coal that contains humic acids due to the weathering process.

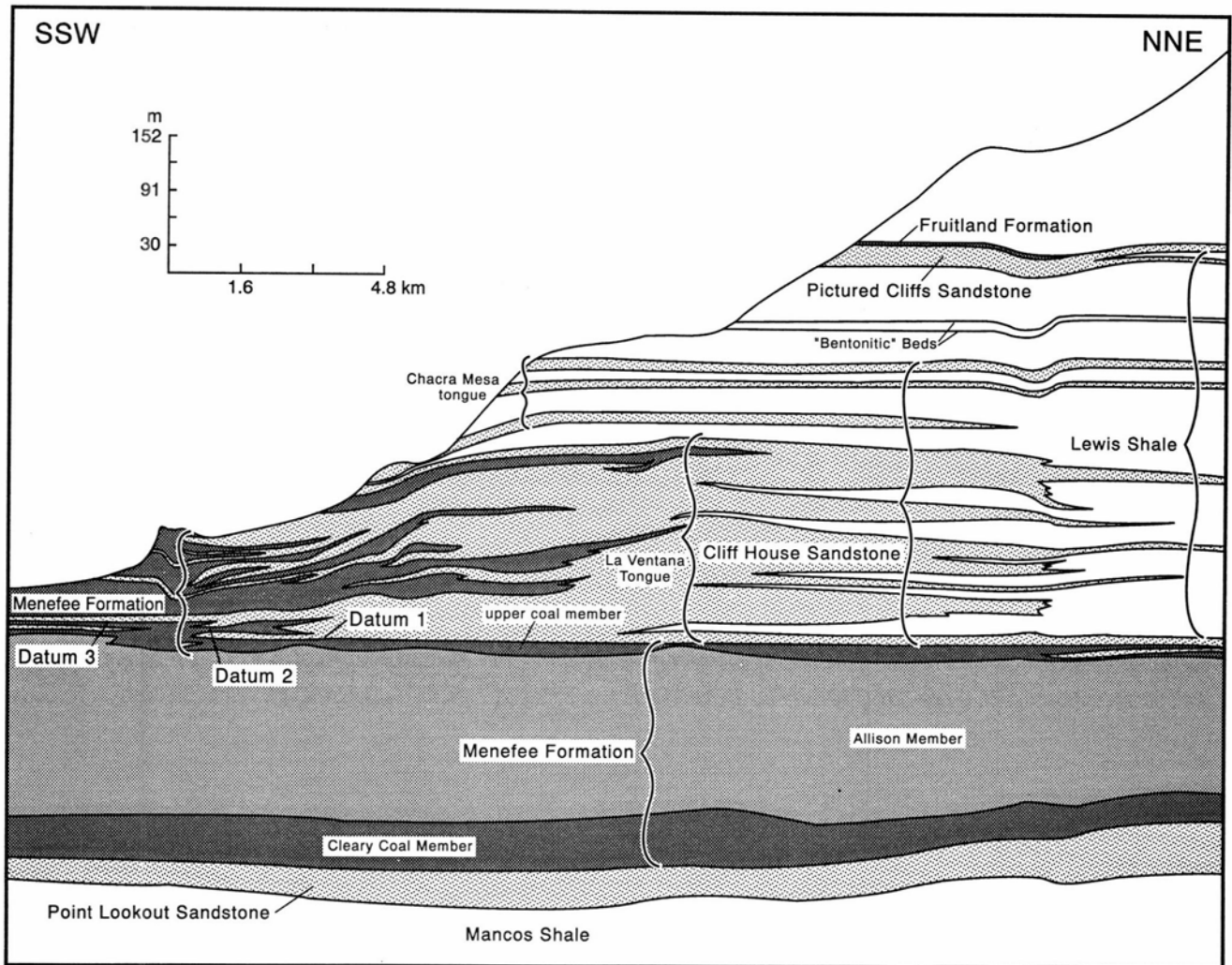

FIGURE 4—Generalized cross section of Torreón–La Ventana area. Approximate location shown in Figure 2. Modified from Beaumont and Hoffman (1992), reproduced with permission of the New Mexico Geological Society.

ing after washing. The addition of ashing steps in the procedure and the reporting of results on an ash-free basis eliminate this problem by reporting only the organic portion of the precipitate. Reporting of HA and especially FA on an ash-free basis eliminates reporting metals contained in the humate structure (Stevenson, 1985) and contaminants such as  $\text{Na}^+$  and  $\text{Cl}^-$  as HA and FA. The percentage of ash in the FA fraction can be as high as 90%.

Although not required for humate analysis, the untreated sample and humin fraction were asked in order to set up a mass-balance check:

$$\text{Eq. 1: } \% \text{ ash-free HA} + \% \text{ ash-free humin} + \% \text{ ash of untreated sample} = 100\%$$

This mass-balance check (Eq. 1) has an average of 5% error and a maximum error of 10%. Samples whose mass balance are above the 10% margin are reanalyzed. This mass-balance check is suitable for carbonaceous mudstone, but is inappropriate for weathered coal and "fresh" coal because volatile matter, fixed carbon, moisture content, iron sulfide, and carbonate minerals are not considered in Equation 1.

Mass balance (Eq. 2) was also used to determine the amount of ash composed of  $\text{NaOH} + \text{HCl}$  salts left after the leaching, precipitation, and washing steps of the ex-

traction procedure. All percentages are based on 1 g of starting material:

$$\begin{aligned} \text{Eq. 2: } & (\% \text{ weight HA ash} + \% \text{ weight FA ash} \\ & + \% \text{ weight humin ash}) \\ & - (\% \text{ weight untreated ash}) \\ & = \% \text{ weight NaOH/HCl ash} \end{aligned}$$

To check this mass balance, six fresh coal samples were analyzed by the 18 step method outlined above. This check showed that significant  $\text{NaOH/HCl}$  residue (3.18.5%) was added. Although these samples had low HA and FA, the data suggest that reporting results on an ash-free basis is more accurate (Table 3).

### Results

A comparison of ash versus HA content was done by Siemers and Wadell (1977) in their analyses of Menefee Formation humate. This comparison of weathered coals and carbonaceous mudstone indicates both a strong linear correlation ( $R = 0.9566$ ) and an inverse relationship between the ash and HA content. We found a similar relationship between percent HA after ashing and percent ash yield of untreated samples (Fig. 5), but  $R$  is higher. The correlation coefficient of HA and ash for 39 samples of carbonaceous-mudstone and weathered-coal samples is 0.9938. The correlation is inverse: the higher the HA con-



TABLE 3—Weight (in percent) of ash from NaOH and HCl.

ID No.	A Untreated ash	B HA ash	C FA ash	D Humin ash	(B+C+D)-A NaOH/HCl ash
17N2W9	16.20	0.20	2.40	18.00	4.40
17N3W22	9.10	0.10	2.40	10.90	4.30
17N4W13	15.50	0.30	3.60	14.70	3.10
18N3W28	8.20	0.30	2.30	10.80	5.20
18N3W21	4.40	0.00	1.80	7.70	5.10
18N3W16	13.30	0.30	2.20	16.30	8.50

tent the lower the ash content. The weathered coals have a higher HA content, but the lack of correlation in the fresh coal indicates that before weathering coal contains little or no HA. Relatively fresh coal samples from cores are also plotted in Figure 5 and show no correlation between HA and ash, owing to very low HA content.

A comparison (Fig. 6) of weathered coals to relatively fresh coal samples from the same formation and member illustrates a significant inverse relationship between HA content and calorific value (MJ/kg-K). A comparison of weathered-coal to carbonaceous-mudstone heat values from HA and the percent HA (ash-free; Fig. 7) shows little difference in the range of calorific values, but a grouping of the two lithologic units on the basis of HA content is possible. The weathered coal has a higher HA content (18-38%) than the carbonaceous mudstone (10—23%). The overlap in values is because of one anomalously high HA value for a carbonaceous-mudstone sample (21.1%) that may be due to an inaccurate lithologic description. The HA percentages of Seimers and Wadell (1977) show weathered coal having a higher percentage of HA. Their values are higher, particularly for the weathered coal (62% avg), which may be in part attributed to not reporting HA on an ash-free basis.

After washing, HA content in weathered coal is twice as high as that in carbonaceous mudstone. The average percent HA (ash-free) is 24.3% for weathered coals and 10.6% for carbonaceous mudstones. The standard deviation of the HA for weathered coal and carbonaceous mudstone is high (Table 4), indicating a wide range in the HA content. The average percentage of ash in the HA precipitate is about the same for both weathered coal (2.32%) and carbonaceous mudstone (1.85%).

The FA content (Table 5) is about the same for both weathered coals (12.59%) and carbonaceous mudstones (13.00%). The ashing greatly reduces this percentage, in

dicating that the FA precipitate averages 70% ash. These results reinforce the need for ashing, particularly for FA analysis.

The percentages of HA and FA in Tables 4 and 5 illustrate that HA is more dependent on lithology than FA. The oxidation or weathering of coal, which has more organic material than carbonaceous mudstone, generates a higher percentage of HA. The FA content appears to be less dependent on lithology and more dependent on the degree of weathering, because it is largely derived from HA (Fig. 3; Swift, 1985).

### End use

Humate is commonly used as a soil amendment (Hoffman and Austin, 1994) or drilling-mud additive. Use

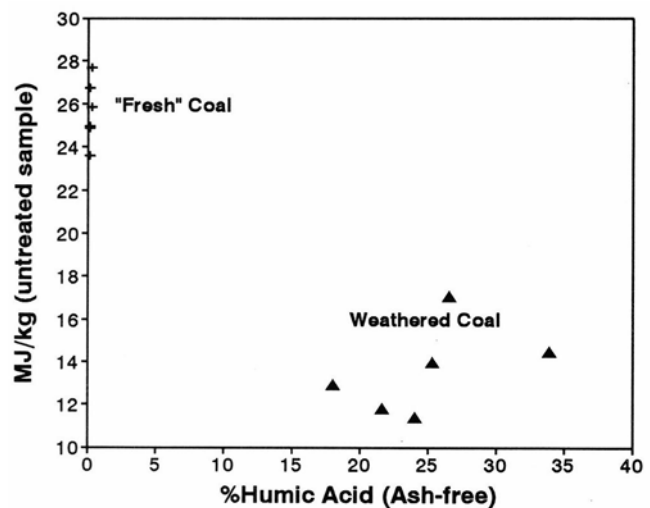

FIGURE 6—Humic-acid (ash-free) versus calorific contents of untreated samples of "fresh" and weathered coal.

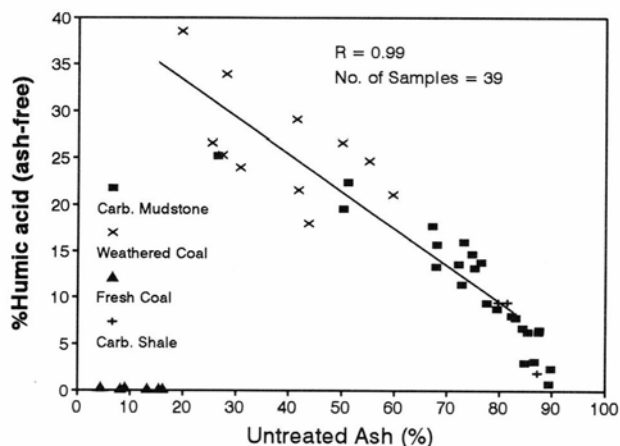

FIGURE 5—Correlation of humic-acid (ash-free) content and ash contents in untreated weathered coal, carbonaceous mudstone, and "fresh" coal samples.

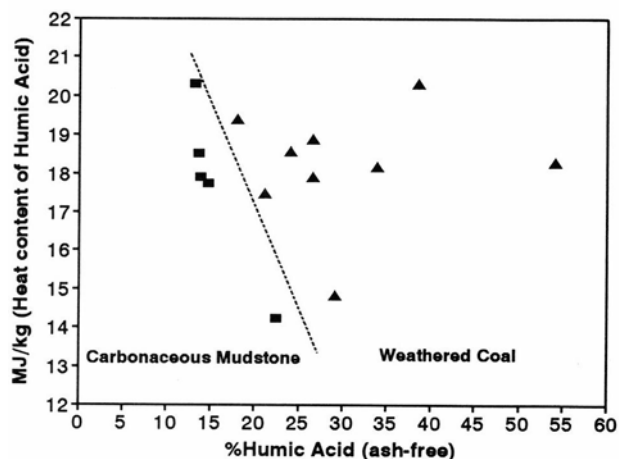

FIGURE 7—Humic-acid (ash-free) content versus calorific content of humic acid in weathered coal and carbonaceous mudstone samples.

TABLE 4—Humic acid (%) content for carbonaceous mudstone, weathered coal, and fresh coal.

Lithology	Average	Std. deviation
<b>Humic Acid</b>		
Carbonaceous mudstone—27 samples		
Total HA (with ash)	12.46	6.61
% of ash of total HA	1.85	0.86
% of HA of total HA	10.61	6.19
Weathered coal—12 samples		
Total HA (with ash)	26.59	8.69
% of ash of total HA	2.32	0.62
% of HA of total HA	24.27	8.60
Fresh coal—6 samples		
Total HA (with ash)	0.43	0.07
% of ash of total HA	0.21	0.11
% of HA of total HA	0.23	0.05

of humic substances in agriculture is controversial primarily because not all soils and plants benefit from their application (typically 448-672 kg /ha for field crops). Humic acids are organic colloids, similar in behavior to clays (Siemers and Wadell, 1977), and they therefore increase the water-retention and cation-exchange capacity of the soil (Gosz et al., 1978). Humic acids raise the acidity of alkali soil, thus increasing the availability of several elements to plants (Siemers, 1975) and stimulating growth of microorganisms that process plant nutrients. Carbonaceous mudstones have more clay than weathered coal, so they are more beneficial than weathered coal in sandy soils for retaining nutrients and moisture. A clay-dominant soil would receive more benefit from a weathered, coal-based humate. The type of clay material in weathered coal and carbonaceous mudstone is dominantly kaolinite (Hoffman et al., 1995). Humic substances also promote formation of soil through the decomposition of rocks and minerals and increase the workability of the soil (Hoffman and Austin, 1994).

As a drilling-mud additive the humic acid in humate acts as a dispersant, thinner or viscosity modifier for clay slurries (Miles and Blair, 1983). Humates are stable at high temperatures and are preferred for drilling at high temperatures. Weathered coal and/or leonardite are preferred for this application because of their high base-soluble humic-acid content (Miles and Blair, 1983). Leonardite and weathered coal have been mined in North Dakota and New Mexico for use as a drilling-mud additive.

Other uses for humate include wood stain, binder for briquets, casting sand additive, and ion-exchange resin stabilizer. Potential or emerging uses are neutralization of herbicides and pesticides, livestock feeds, environmental soil stabilization, or feedstock for synfuels.

### Summary

Weathered coal and carbonaceous mudstone contain different amounts of HA and FA. The HA, FA, and humin contents are determined using a simplified method of basic washings and acid precipitation. The addition of ashing steps to the procedure and reporting of HA and FA on an ash-free basis enhance accuracy and precision by eliminating differences due to varying leach times, varying NaOH-HCl concentrations, and residues remaining after washing (Verploegh and Brandvold, 1990).

Analyses of upper coal member, Cleary Coal Member (Menefee Formation), and Fruitland Formation samples from the southeast SJB suggest that ashing is particularly important in determining the true FA content. Ash

TABLE 5—Fulvic acid (%) content for carbonaceous mudstone, weathered coal, and fresh coal.

Lithology	Average	Std. deviation
<b>Fulvic Acid</b>		
Carbonaceous mudstone—27 samples		
Total FA (with ash)	13.00	2.01
% of ash of total FA	9.64	2.02
% of FA of total FA	3.36	1.66
Weathered coal—12 samples		
Total FA (with ash)	12.59	3.08
% of ash of total FA	9.06	2.98
% of FA of total FA	3.53	1.84
Fresh coal—6 samples		
Total FA (with ash)	4.27	0.68
% of ash of total FA	2.44	0.56
% of FA of total FA	1.83	0.38

in the total FA precipitate averages 70% compared to 2% in HA.

The weathered-coal resource in the La Ventana-Chacra Mesa area is estimated to be 1.1 Gt, averaging 24.3% HA and 3.5% FA (ash-free). The carbonaceous-mudstone resource for this area is estimated to be 2.3-3.4 Gt and to contain 10.6% HA and 3.4% FA (ash-free). The total humate resource in New Mexico has been estimated at 11 Gt, almost all of which is in the SIB.

### Acknowledgments

The authors thank G. S. Austin and L. A. Brandvold, NMBMMR, for their helpful comments, and J. T. Spence, Mesa Verde Resources, for samples and insight into the humate industry. Figures are by Kathy Glesener and Rebecca Titus, NMBMMR cartographers.

### References

- Aiken, G. R., McKnight, D.M., Wershaw, R.L., and MacCarthy, P., 1985, An introduction to humic substances in soil, sediment and water; *in* Aiken, G.R., McKnight, D.M., Wershaw, R.L., and MacCarthy, P. (eds.), Humic substances in soil, sediment and water: John Wiley, New York, pp. 1-9.
- Beaumont, E. C., 1971, Stratigraphic distribution of coal in San Juan Basin; *in* Shomaker, J. W., Beaumont, E. C., and Kottowski, F. E., (eds.), Strippable low-sulfur coal resources of the San Juan Basin in New Mexico and Colorado: New Mexico Bureau of Mines and Mineral Resources, Memoir 25, pp. 15-30.
- Beaumont, E. C., and Hoffman, G. K., 1992, Interrelationships between the upper coal member of the Menefee Formation, the La Ventana Tongue, and the Lewis Shale in southeastern San Juan Basin, New Mexico: New Mexico Geological Society, Guidebook 41, pp. 207-216.
- Broughton, P. L., 1972, Identification of leonardite, a naturally oxidized lignite, by low-angle X-ray scattering method: *Journal of Sedimentary Petrology*, v. 42, pp. 356-358.
- Burdick, E. M., 1965, Commercial humates for agriculture and the fertilizer industry: *Economic Botany*, v. 19, pp. 152-156.
- Fowkes, W. W., and Frost, C. M., 1960, Leonardite—A lignite byproduct: U.S. Bureau of Mines, Report of Investigations 5611, 12 pp.
- Gosz, J. R., Barton, L., and Potter, L. D., 1978, An evaluation of New Mexico humate deposits for restoration of mine spoils, Final Report: New Mexico Energy Resources Board, Grant 75- 121, 15 pp.
- Hoffman, G. K., Campbell, F. W., and Beaumont, E. C., 1993, Quality assessment of strippable coals in northwestern New Mexico—Fruitland, Menefee, and Crevasse Canyon Formation coals in San Juan Basin, and Moreno Hill Formation coals in Salt Lake field: New Mexico Bureau of Mines and Mineral Resources, Bulletin 141, 84 pp.
- Hoffman, G. K., and Austin, G. S., 1994, Agricultural materials soil additives; *in* Carr, D. D. (ed.), Industrial minerals and

- rocks (6th ed.): Society for Mining, Metallurgy and Exploration, Littleton, Colorado, pp. 89-96.
- Hoffman, G. K., Barker, J. M., and Austin, G. S., 1995, Overview of humate production in North America; *in* Merlini, A. A. S., (ed.), Proceedings of the 30th Forum on the Geology of Industrial Minerals [1994], New Brunswick Department of Natural Resources and Energy, Minerals and Energy Division, Miscellaneous Report 16, pp. 55-70.
- Kohanowski, N. N., 1970, Leonardite in North Dakota: North Dakota Quarterly, v. 38, no. 2, pp. 36-42.
- Krauskopf, K. B., 1967, Introduction to geochemistry: McGraw-Hill, New York, 721 pp.
- Miles, W. J., and Blair, R. E., 1983, Industrial minerals uses in the drilling industry: Mining Engineering, v. 30, pp. 1397-1400.
- Roybal, G. H., and Barker, J. M., 1987, Geology and production of humate and weathered coal in New Mexico: Transactions of the Society for Mining, Metallurgy, and Exploration Inc., v. 280, pp. 2105-2110.
- Siemers, C. T., 1975, Humate and associated deposits of the lower part of the Menefee Formation: Rocky Mountain Section, American Association of Petroleum Geologists and Society of Economic Paleontologists and Mineralogists, Annual Meeting, Guidebook, Field trips to central New Mexico, Part 1, pp. 39-46.
- Siemers, C. T., and Wadell, J. S., 1977, Humate deposits of the Menefee Formation (Upper Cretaceous), northwestern New Mexico: New Mexico Geological Society, Guidebook 28, Supplement, pp. 1-21.
- Stevenson, F. J., 1985, Geochemistry of soil humic substances; *in* Aiken, G. R., Mcknight, D. M., Wershaw, R. L., and MacCarthy, P. (eds.), Humic substances in soil, sediment and water: John Wiley, New York, pp. 13-52.
- Stevenson, F. J., 1982, Humus chemistry—Genesis, composition, and reactions: John Wiley, New York, 443 pp.
- Swanson, V. E., 1977, Definition and description of humate: U.S. Geological Survey, [Unpublished report].
- Swanson, V. E., and Ging, T. G., 1972, Possible economic value of trona-leonardite mixtures: U.S. Geological Survey, Professional Paper 800-D, pp. 71-74.
- Swift, R. S., 1985, Fractionation of soil humic substances; *in* Aiken, G. R., Mcknight, D. M., Wershaw, R. L., and MacCarthy, P. (eds.), Humic substances in soil, sediment and water: John Wiley, New York, pp. 387-408.
- Verploegh, J. M., and Brandvold, L. A., 1990, Optimization of the analyses of humic and fulvic acid in soil humates: [Unpublished report], New Mexico Bureau of Mines and Mineral Resources, 9 pp.

# Economic geology of the St. Cloud Mining Company (Cuchillo Negro) clinoptilolite deposit, Sierra County, New Mexico

John L. White<sup>1</sup>, William X. Chavez, Jr.<sup>2</sup>, and James M. Barker<sup>3</sup>

<sup>1</sup>*St. Cloud Mining Company, P. O. Box 1670, Truth or Consequences, New Mexico 87901, USA*

<sup>2</sup>*Department of Mineral and Environmental Engineering, New Mexico Tech, 801 Leroy Place, Socorro, New Mexico 87801-4796, USA*

<sup>3</sup>*New Mexico Bureau of Mines & Mineral Resources, New Mexico Tech, 801 Leroy Place, Socorro, New Mexico 87801-4796, USA*

**Abstract**—The Tertiary tuff of Little Mineral Creek and overlying rocks that crop out along Cuchillo Negro Creek at the southern end of the Winston graben have been partly zeolitized. Clinoptilolite from these rocks is mined and processed by St. Cloud Mining Company about 4 mi south of Winston, Sierra County, New Mexico, in secs. 2-3, 10-11, 14-15, 22, T12S R8W.

St. Cloud, using 20 employees, mines 12-35 ft thick clinoptilolitic tuffs within a 600-800 ft thick section of interbedded tuffaceous and conglomeratic sedimentary rocks. Raw ore is about 50-85% clinoptilolite and is produced by careful stripping of approximately 70 ft of overburden. The ore is blasted and loaded into trucks for the 1.5 mi haul to the plant. The -20 inch feed is crushed in jaw, cone, and impact crushers and is dried prior to passing over multiple screens that produce 11 product grades. This clinoptilolite has greater potassium, hardness, and density than is typical and contains no fibrous mineral.

Clinoptilolite production was 22,000 short tons (st) in 1994 and will reach about 30,000 st in 1995 making this operation the leading domestic natural zeolite producer. About 73% of production is used in animal hygiene, 16% in animal feed, and 11% in environmental mitigation, air and water filtration, and other applications. Most St. Cloud clinoptilolite is shipped in bulk by rail (60% via the Engle siding east of Truth or Consequences, New Mexico) or by truck (40%); some bags and supersacks are also utilized. Markets are nationwide and reach about 200 customers, 10 of whom take 60-70% of production, mostly through brokers, distributors, or by direct shipments. Only a small portion of output is marketed under the St. Cloud "Stone House" brand.

Preliminary petrology shows that clinoptilolite is the most abundant mineral in the tuff at the mine, with volumetrically minor to trace quantities of quartz and sanidine. Pre-zeolitization host-rock for the deposit was probably a series of rhyolitic airfall tuffs (Miocene?) that contained trace mafic minerals. Host-rock grain diameters are generally less than 0.08 inches in greatest dimension, and outcrops show laminar to thin bedding. In some exposures only relic bedding is preserved as wispy laminations. Interbedded with the zeolitic tuff units are laterally discontinuous channel-filling deposits of poorly to moderately sorted gravel, including clasts of locally derived hornblende andesites and rhyolites. These interbeds are approximately 2-12 ft thick, and apparently represent alluvial (?) channels developed on the original tuff surfaces. The zeolite resource is large and extends relatively continuously across a 1 mi by 3 mi south-southwest trend.

## Geología económica del yacimiento de clinoptilolita *Cuchillo Negro*, Condado Sierra, Nuevo Mexico, de la Compañía Minera St. Cloud

**Resumen**—La toba volcánica terciaria de *Little Mineral Creek* y rocas superpuestas que afloran en *Arroyo Cuchillo Negro* en el extremo sur del *Graben de Winston* han sido parcialmente zeolitizadas. *St. Cloud Mining* extrae y procesa clinoptilolita de estas rocas. La mina se encuentra 4 millas al sur de la localidad de *Winston*, en secciones 2-3, 10-11, 14-15, 22, T12S R8W.

Con 20 empleados, *St. Cloud* trabaja tobas clinoptilolíticas de 12-35 pies de espesor. Estas capas están intercaladas en una sección de 600-800 pies en que alternan sedimentos tobáceos y conglomerados. El mineral crudo contiene entre 50-85% de clinoptilolita. Para la producción primero se remueven cuidadosamente unos 70 pies de sobrecarga dejando al cubierto las capas productivas. Luego el mineral se dinamita, se rompe y se carga en camiones para el transporte a la planta, distante 1.5 millas. El mineral que entra a la planta, en trozos de 20 pulgadas, es triturado sucesivamente en trituradoras de mandíbula, de cono, de impacto; luego se lo seca y pasa por tamices múltiples que producen once grados del producto. La clinoptilolita de este yacimiento tiene mayor contenido de potasio de lo que es común y también es más dura y densa; no contiene mineral fibroso.

En 1994, la producción fue de 22,000 toneladas cortas (*short tons*) y alcanzará las 30,000 toneladas en 1995, con lo que esta operación llegará a ser el mayor productor doméstico de zeolita natural. Un 73% de la producción se utiliza para higiene animal, el 16% es para forraje y el 11% para saneamiento ambiental, filtración de agua y usos misceláneos. El 60% del producto es despachado suelto por ferrocarril (desde el ramal ferroviario de *Engle* al este de *Truth or Consequences*) y el 40% va por camión de carga. También se envasa alguna cantidad en bolsas y superbolsas.

## Introduction

The Tertiary tuff of Little Mineral Creek and overlying tuffaceous sedimentary rocks (Harrison, 1986) have been variably altered to clinoptilolite, most likely by alkaline/saline meteoric and/or low-temperature hydrothermal fluids in an open hydrologic system. The zeolitic units include the clinoptilolitic tuff and conglomerate unit of Maxwell and Hey! (1976). The deposit was termed the Cuchillo Negro clinoptilolite deposit by Bowie et al. (1987). It is exposed in the southern end of the Winston graben and at numerous localities in the adjacent Black Range and Sierra Cuchillo. The clinoptilolite deposit is currently mined about 4 mi south of Winston (Fig. 1) and is accessible via County Road 6 and Forest Route 157. The mine is in secs. 2-3, 10-11, 14-15, 22, T12S R8W.

The purpose of this paper is to describe the economic and geologic characteristics of the Cuchillo Negro clinoptilolite deposit. A description of the present St. Cloud Mining Company clinoptilolite operation is also provided.

## History

Leonard Minerals Company and Todilto Exploration and Development Corporation, both of Albuquerque, New Mexico, investigated the Cuchillo Negro clinoptilolite resource in the 1980s, but no production occurred. St. Cloud Mining Company conducted an evaluation of the

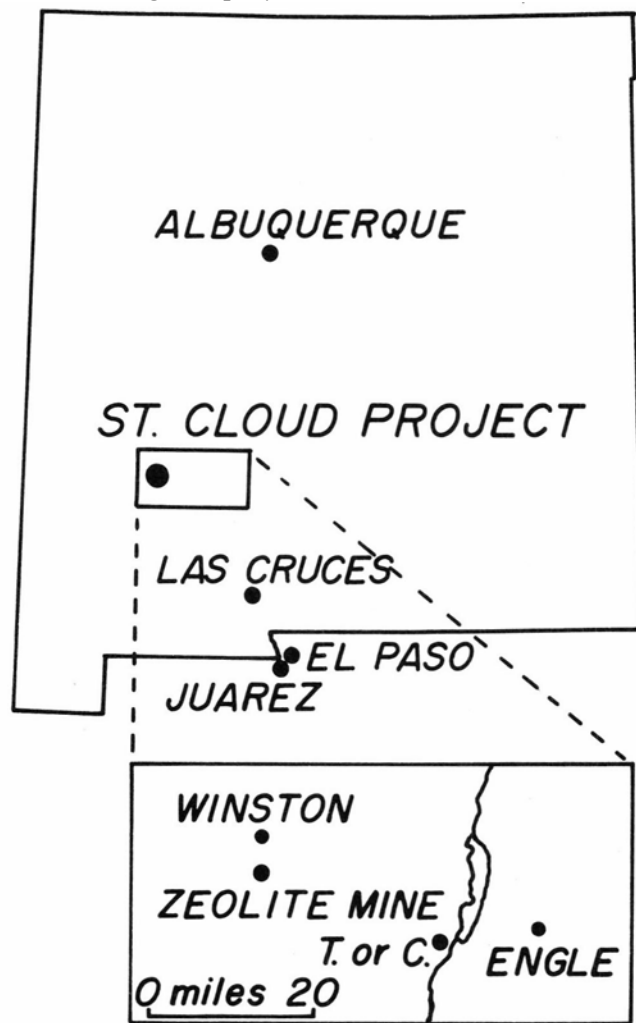

FIGURE 1—Location of the St. Cloud Cuchillo Negro clinoptilolite operation in New Mexico. Note that "T. or C." is the town of Truth or Consequences, New Mexico, at the south end of Elephant Butte Lake on the Rio Grande.

feasibility of mining the deposit in 1990, and production and sales of clinoptilolite by St. Cloud began that year.

## Geology

Most of the rocks in the Sierra Cuchillo area represent an intermediate to felsic volcanic and volcanoclastic sequence within a complex volcano-sedimentary section that is at least 2,300 ft thick (Harrison, 1986). Figure 2 is a stratigraphic column of the middle and upper Tertiary section in the Winston area. The period of volcanism represented by this volcanic sedimentary stratigraphy concluded with deposition of the tuff of Little Mineral Creek. Overlying this unit is a sequence of immature tuffaceous volcanoclastic rocks that are compositionally similar to the tuff of Little Mineral Creek. Capping these rocks is a thick sequence of unconsolidated conglomerates of the Santa Fe Formation. The contact between the tuffaceous clastic unit and the conglomerates of the Santa Fe Formation is conformable and gradational.

Zeolite alteration occurs in the Santa Fe Formation, tuffaceous sediments, the tuff of Little Mineral Creek, and the underlying volcanic units. However, only the tuff of Little Mineral Creek and the overlying tuffaceous sediments host clinoptilolite-bearing rocks of sufficient size and concentration to be of commercial significance.

The general geologic ages shown in Figure 3 are derived from radiometric ages compiled by Harrison (1986, 1989) from various sources. Rio Grande rift extensional tectonics were initiated about 28 million years ago. This corresponds closely to the beginning of deposition of the tuffaceous basal unit of the Santa Fe Formation, which overlies the tuff of Little Mineral Creek.

The relationships of zeolite occurrences to regional geological features are illustrated in Figures 4 and 5. Zeolitized rock units occur within the Winston graben, a structure that parallels the Rio Grande rift and is comparable in age (Fig. 6). Most exposures within the graben consist of unconsolidated conglomerates of the Upper Tertiary and Quaternary Santa Fe Formation. Rocks that host commercial clinoptilolite alteration are exposed in a small erosional window in the south end of the graben.

Host rocks for commercial-grade clinoptilolite alteration include the tuff of Little Mineral Creek, a lithic-rich rhyolitic ash flow crystal tuff that is about 600 ft thick, and a tuffaceous sedimentary sequence from 50 to 200 ft thick that overlies the tuff of Little Mineral Creek. The tuffaceous sediments consist of immature tuffaceous

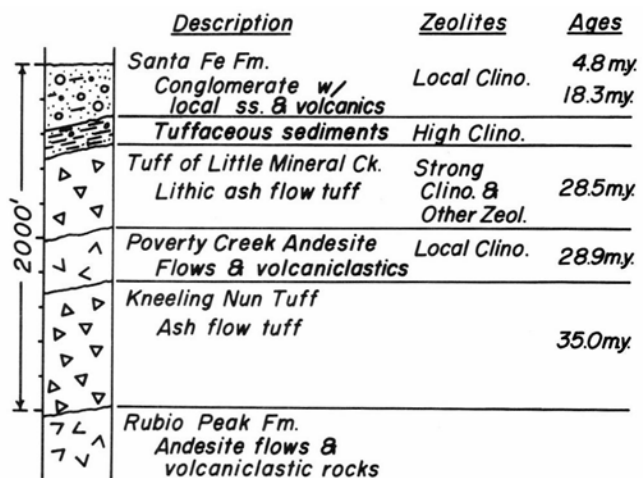
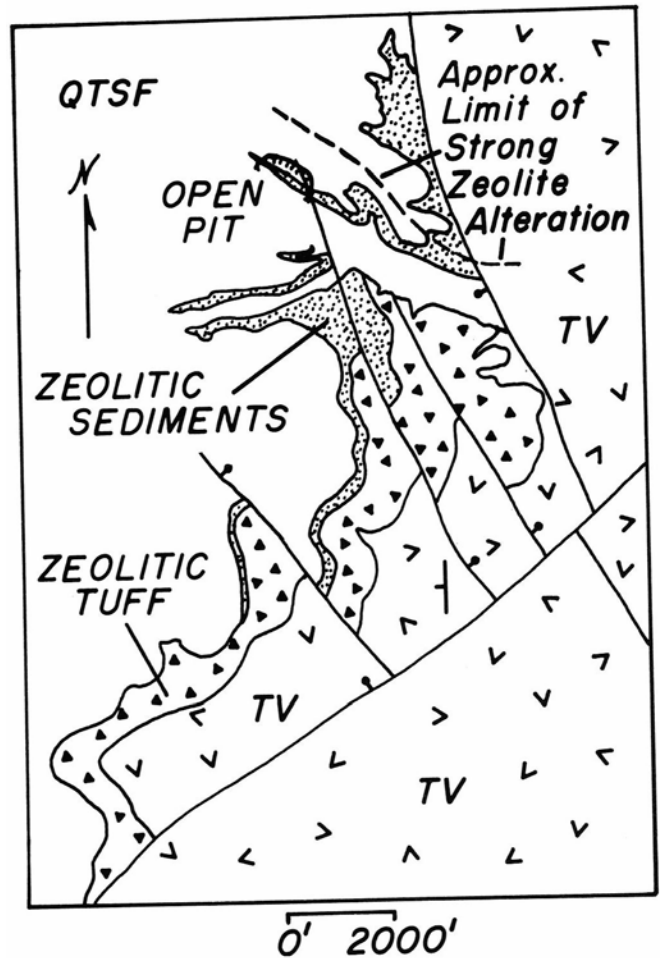
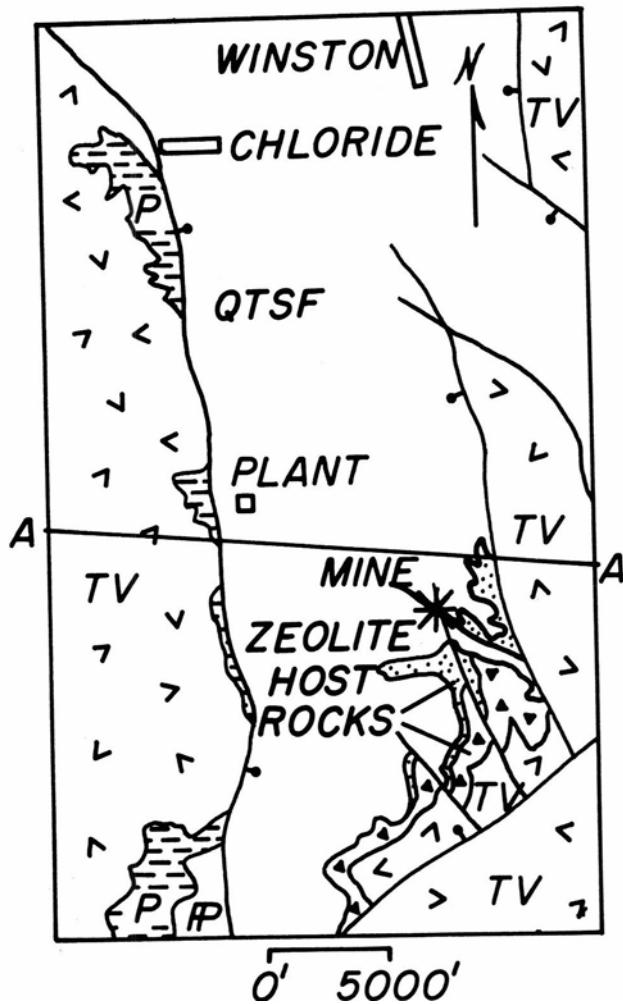
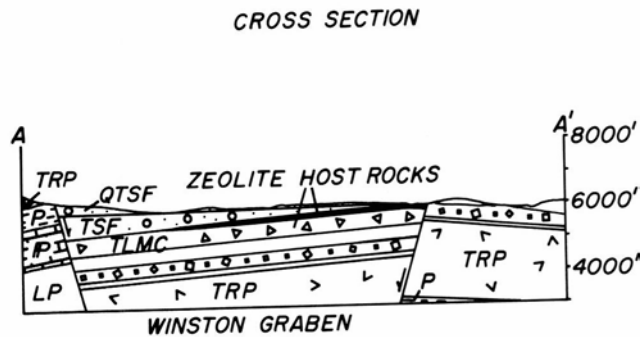

FIGURE 2—Stratigraphy in the vicinity of the St. Cloud Cuchillo Negro clinoptilolite operation. Modified from Harrison, 1986.



Limestone Modified from Harrison (1986).

FIGURE 3—Generalized geology of a portion of the Winston graben. Cross section along A-A' is shown in Figure 4. Zeolite host rocks include the tuff of Little Mineral Creek (solid triangle pattern) and tuffaceous sedimentary rocks overlying the tuff of Little Mineral Creek (stippled pattern). Rock unit abbreviations are as follows: QTSF—Santa Fe Formation, TV—Undifferentiated Tertiary rocks stratigraphically below tuff of Little Mineral Creek, P—Permian Abo Formation, p—Pennsylvanian Madera



From Harrison, 1989

FIGURE 4—Vertical cross section across the Winston graben, looking north. Cross section shows zeolite host rocks preserved within the Winston graben. Rock unit abbreviations: QTSF—Santa Fe Formation upper unit, TSF—Santa Fe Formation lower unit, TLMC—tuff of Little Mineral Creek, TRP—Rubio Peak Formation, P—Permian Abo Formation, p—Pennsylvanian, LP—undifferentiated Paleozoic Rocks. Modified from Harrison (1986).



FIGURE 6—View looking west-northwest at outcrops of zeolitized tuffs in a portion of the Winston graben. In the background Paleozoic sedimentary units are separated by a graben-bounding fault (dashed lines). Cuchillo Negro Creek is in the foreground.

FIGURE 5—Generalized geology adjacent to the St. Cloud Cuchillo Negro deposit showing lateral limit of strong clinoptilolite development. Potential clinoptilolite and other zeolite resources occur south of the current mine. Millsite is approximately 1.5 mi northwest of the mine. Commercial clinoptilolite alteration occurs in the tuff of Little Mineral Creek (solid triangle pattern) and overlying tuffaceous sedimentary rocks (stippled pattern) south of the dashed line indicated as the limit of strong clinoptilolite alteration. Other rock units are: QTSF—Santa Fe Formation, TV—Undifferentiated Tertiary rocks stratigraphically below the tuff of Mineral Creek.



arenite interbedded with tuffaceous conglomerates with clast compositions similar to the lithic fragments of the underlying tuff of Little Mineral Creek. These rock units are exposed in the mine vicinity along a strike length of about 3 mi. However, field studies indicate that potentially commercial clinoptilolite alteration occurs along nearly 2.5 mi of strike length of these variably zeolitized volcano—sedimentary rocks. Figure 5 shows the lateral extent of clinoptilolite alteration. North of the zone of strong clinoptilolite development, the tuffaceous volcanoclastic rocks are relatively unaltered or only incipiently altered. South of this zone host rocks are strongly altered to clinoptilolite (Fig. 7). Detailed descriptions of relatively unaltered and altered samples of this rock unit are given in the following section.

### Petrographic descriptions

#### Relatively unaltered host rocks

Samples collected in an area approximately 2,000 ft northeast of the St. Cloud open pit (Fig. 5) comprise a series of volcanoclastic arenites, probably derived from the erosion or immediate post-deposition transportation of a vitric crystal tuff. In some samples crude bedding suggests that these rocks were deposited in laminar horizons, perhaps in a distributary alluvial fan environment. Figures 8 and 9 show representative outcrops of zeolitic rocks in the Cuchillo Negro area. Lithic fragments comprise 2-7 vol.% of these clastic rocks, and consist of trachytic-texture, fine-grained andesite, rhyolite (tuff?), and subrounded quartz fragments.

Phenocryst contents range from 45-55 vol.%, with quartz, K-feldspar, plagioclase, and volumetrically minor mafic minerals the principal constituents. K-feldspar comprises approximately 70-80 vol.% of total feldspar. Total feldspar content of these clastic rocks varies from approximately 25 to 30 vol.%, and total phenocryst quartz varies from 20 to 25 vol.%. Pale green to brownish-green biotite occurs as anhedral to subhedral phenocrysts, and is unreplaced or may show replacement by red hematite  $\pm$  quartz  $\pm$  white phyllosilicate. Total biotite content varies from 2 to 5 vol.%. Hornblende phenocrysts occur in trace quantities, and show incipient replacement by white phyllosilicate. Clinopyroxene constitutes 1-3 vol.% of a given sample and shows no apparent replacement; orthopyroxenes are not observed from the three sample sites studied.

Alteration mineralogy comprises a volumetrically vari-



FIGURE 7—View west-southwest from same spot as Figure 6, showing prominent outcrops of volcanic units, mostly variably-welded tuffs, south of current St. Cloud mine. White to pale-gray units at the right side of the figure are zeolitized tuffs.

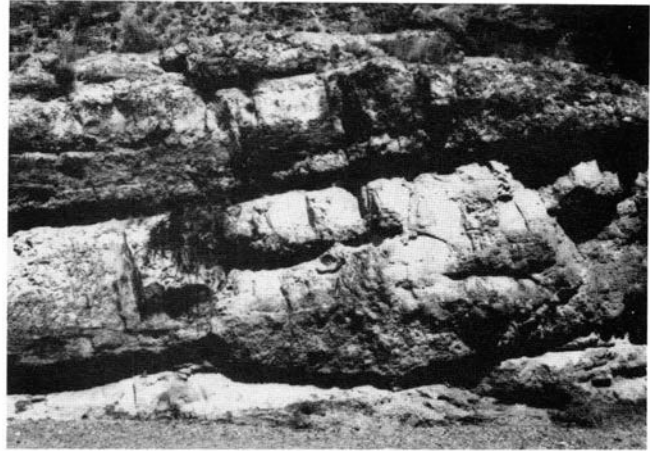

FIGURE 8—Representative outcrop of tuff, showing fine-grained to conglomeratic (?) horizons; hammer for scale in lower center. Located about 2,000 ft south of the St. Cloud mine.

able assemblage of carbonate, white phyllosilicate, quartz, red hematite, and zeolite. Feldspars generally show only incipient replacement, with plagioclase phenocrysts replaced by white phyllosilicate + quartz. Biotite and trace hornblende are variably replaced, with quartz, red hematite, white phyllosilicate, and scant rutile observed as alteration products. Carbonate occurs as irregular, patchy masses less than 0.04 inches in diameter. Most of the carbonate occurs as a replacement phase of K-feldspar phenocrysts and appears to fill possible pumice shard sites.

Zeolite, as probable clinoptilolite, occurs as blocky, tabular crystals filling void spaces and as a replacement of K-feldspar phenocrysts. Glassy patches, which are probably relic pumice clasts, appear to have undergone only incipient zeolitization, with some clasts preserving well-developed "onion-skin" texture. Mafic minerals do not appear to have been replaced by zeolite.

Although these rocks contain a significant volcanic component, the rocks are friable and show no emplacement-related alteration; neither welding nor vapor-phase mineralization-alteration occur. Thus, the alteration observed is related to low-temperature, diagenetic processes. No evidence exists for penetrative deformation or for significant compaction of the rock units, suggesting also that burial depths were likely shallow, resulting in nominal grain-to-grain consolidation.



FIGURE 9—Faulted zeolitized tuff located about 2,500 ft southeast of the St. Cloud mine. Faulting is interpreted to be post-zeolitization because no zeolitization or silicification occurs along the fault surface.

We interpret these rocks to have undergone incipient zeolitization, generally involving volumetrically minor replacement of groundmass and feldspar phenocrysts. Mafic minerals appear to have been replaced by the assemblage quartz + red hematite  $\pm$  rutile  $\pm$  white phyllosilicate, with no attendant zeolite development.

### Zeolite-bearing rocks

Rock samples collected at the St. Cloud clinoptilolite mine show well-developed zeolitization of a vitric crystal tuff protolith, including replacement of all phenocryst minerals, with relic and volumetrically trace quartz, biotite, and clinopyroxene(?).

Lithic fragments show clinoptilolite development as a replacement phase of plagioclase microcrysts (andesite clasts) and K-feldspar (rhyolite clasts). Quartz phenocrysts do not show complete zeolitization, and quartz fragments do have local, micrometer-scale quartz overgrowths. Quartz also appears to be a volumetrically trace product of clinoptilolite genesis. Feldspar phenocrysts showing replacement by clinoptilolite have associated quartz, suggesting that at least some of the quartz present in the samples is derived from feldspar replacement.

Cloudy groundmass alteration appears to consist of fine-grained zeolite with scant Fe-oxide (hematite?). Although no amorphous silica was observed, it is possible that such exists within the samples studied if such silica occurs as micrometer-scale masses associated with (cloudy) groundmass-replacing zeolite. Quantitative X-ray diffraction analyses of two zeolitized tuff samples indicate less than 0.1 wt.% SiO<sub>2</sub> as crystalline quartz.

Zeolite occurrence does not appear to have been preferentially developed along bedding planes within tuff or tuff-clastic units in the mine area. The availability of fine-grained volcanoclastic and tuff horizons for zeolitization apparently favored replacement of groundmass and (finer-grained) phenocrysts. The occurrence of quartz as micrometer-scale overgrowths on quartz phenocrysts suggests that silica was mobile during zeolitization; apparently at least some of this silica precipitated as quartz, with amorphous silica as a possible but as yet undocumented coproduct. Replacement of groundmass and phenocrysts varies from approximately 85 vol.% replacement to essentially complete zeolitization.

### Summary of geology

The rocks that host the clinoptilolite alteration at St. Cloud represent a transition from a period of deposition related to regional volcanism followed by a period of extensional tectonism and graben filling related to regional volcanism and formation of the Winston graben. Host rocks for the clinoptilolite deposits are an ashflow tuff and an overlying sequence of immature tuffaceous sediments deposited just before or in conjunction with the initiation of extension and graben development. Tuffaceous units in which the highest quality clinoptilolite deposits occur appear to have formed during a brief period of fluvial reworking of the tuff of Little Mineral Creek prior to the Winston area being overwhelmed by a thick sequence of conglomerates characteristic of the Santa Fe Formation.

Petrographic evidence suggests that at some later time, yet to be determined, the host rocks were altered by relatively low-temperature, diagenetic processes to clinoptilolite. Alternative explanations for the development of the clinoptilolite alteration are discussed in Bowie and Barker (1986).

### Production

Commercial clinoptilolite is mined by St. Cloud using open-pit mining methods (Fig. 10). The company employs a total of 20 workers at the mine and plant. Unconsolidated Santa Fe Formation conglomerates comprising overburden is removed using a Caterpillar D-9 bulldozer and a Cat 988 front-end loader. The upper surface of the clinoptilolite bed to be mined is swept clean of loose overburden using a compressed-air blow pipe (Fig. 11). The bed is then drilled, blasted, and loaded into a 30-short ton (st) haul truck. Ore is hauled 1.5 mi to the St. Cloud mill (Fig. 12) where the material is crushed, dried, and



FIGURE 10—View looking north at St. Cloud mine showing open pit, reclamation (to right), and overburden character.



FIGURE 11—Zeolitized tuff exposed in St. Cloud mine. Note laminar bedding and homogeneous, conchoidal fracturing of tuff. Bench height is about 25 ft.

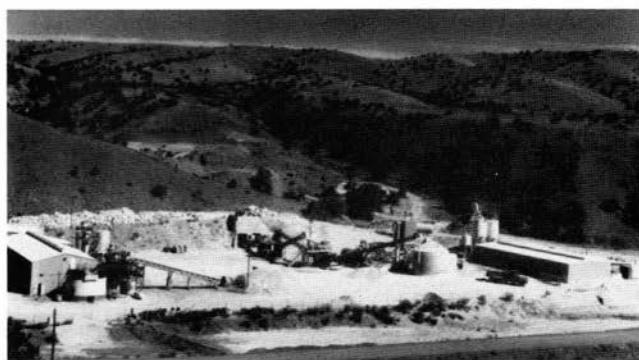

FIGURE 12—St. Cloud plant site, looking north. Stockpiles show clinoptilolite ore and crushed products; hoppers at right store bulk clinoptilolite prior to packaging.

screened to various sizes as specified by customers. A flow sheet of the plant is provided in Figure 13. Aside from drying, sorting, and packaging, no other beneficiation or treatment of the clinoptilolite is done prior to product sale.

Clinoptilolite production by St. Cloud was initiated in 1990 and has grown in volume of production every year since. Production was 22,000 st in 1994 and is projected to reach 30,000 st in 1995. Figure 14 summarizes total production through 1994.

**Marketing**

Approximately 73% of all St. Cloud clinoptilolite products are sold in bulk (Fig. 15), with the remaining 27% of

products packaged in various sized paper bags or super sacks. About 32% of sales are made through private brokers or as private label products (Fig. 16), and only about 10% is sold in packages bearing the St. Cloud Mining Company's "Stone House" label used for retail sale.

For the year 1994 shipments were made throughout the United States as well as to customers in Canada and Mexico. Ten customers comprise at least 60-70% of all sales. Although all products are shipped from the St. Cloud plant by truck, 58% of the products are currently transloaded into rail cars at a facility at Engle, New Mexico, about 70 mi east of the mill.

St. Cloud produces natural clinoptilolite in a variety of size classifications and package sizes to meet customer

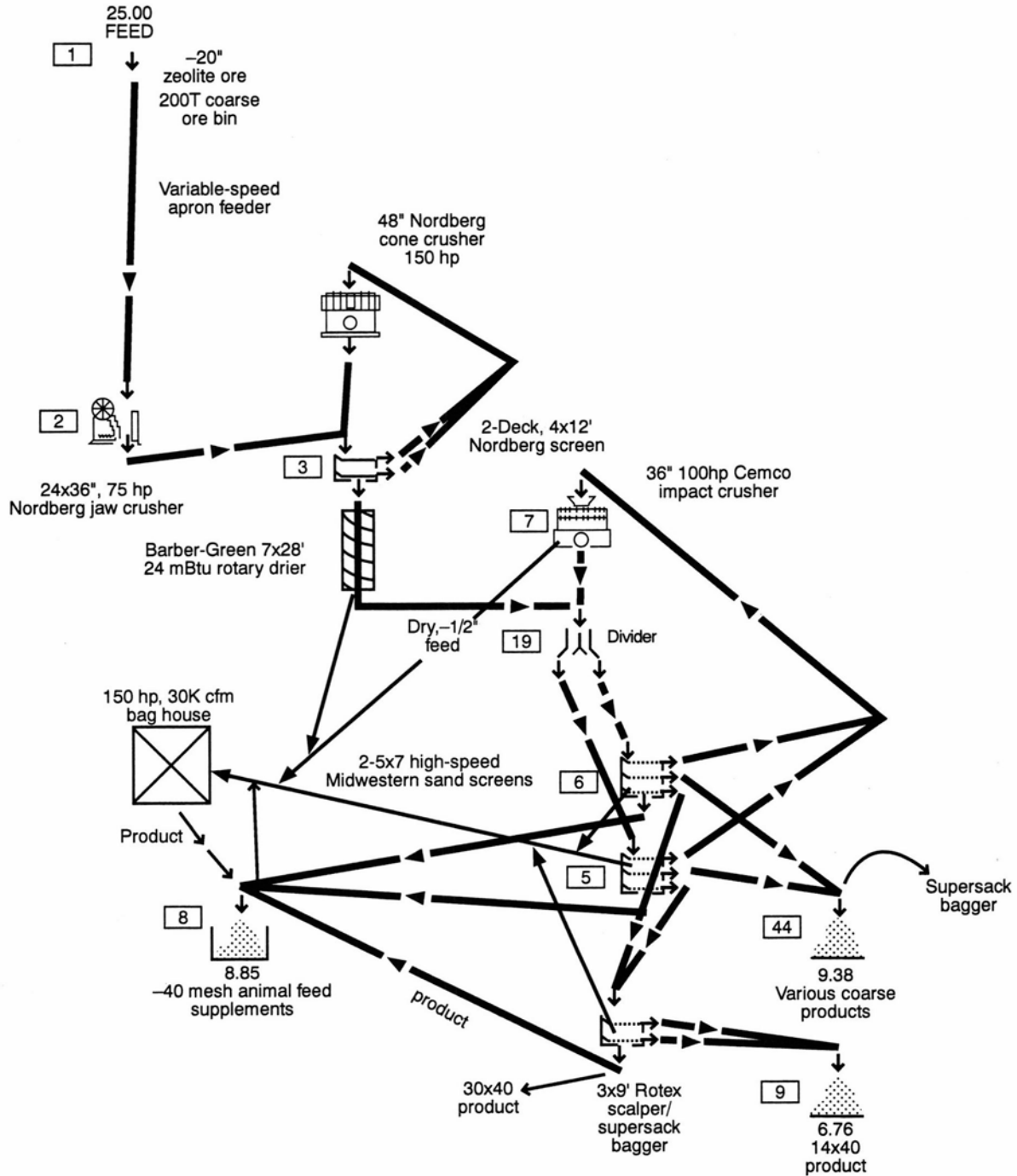

FIGURE 13—Flowsheet of St. Cloud crushing and screening plant. Feed begins in upper left with 25 st per hour (st/hr). Various sized products emerge at the bottom. Numbers (8.85, 6.76, and 9.38) are in st/hr.

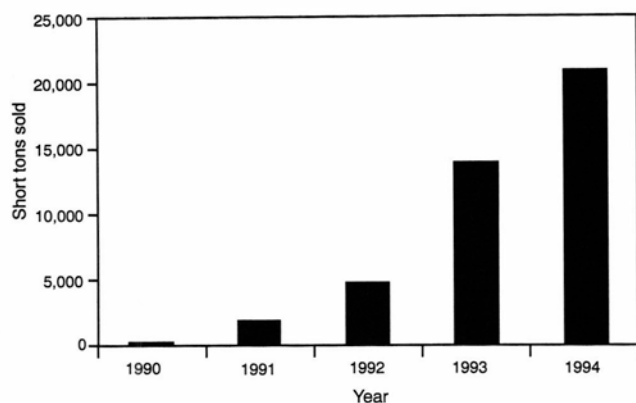

FIGURE 14—St. Cloud clinoptilolite production for the period 1990–1994.

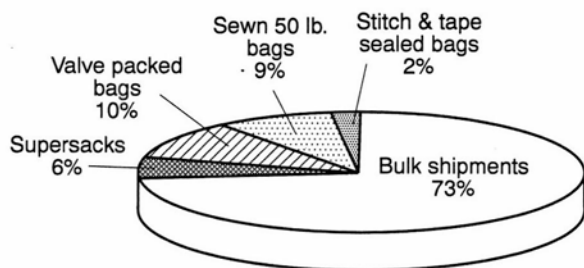

FIGURE 15—Distribution of clinoptilolite product packaging methods used from August 1994 to January 1995.

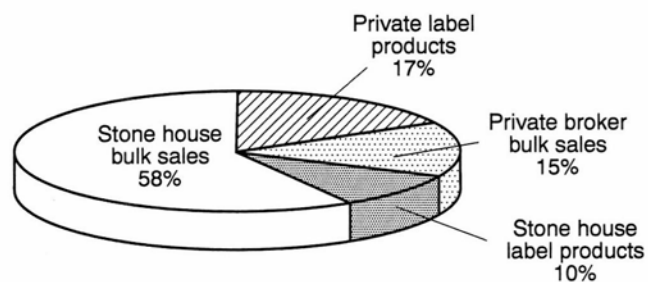

FIGURE 16—Distribution of bulk sales and labeling methods used by St. Cloud from August 1994 to January 1995.

needs (Table 1). Table 2 lists a summary of St. Cloud product specifications.

Animal hygiene, which includes cat litter and other animal bedding products, is the largest application comprising about 73% of material sold in 1994 (Fig. 17). Animal feeds were 16% of plant production in 1994. The remaining 11% of production was used in floor cleaning

TABLE 1—Standard-size specifications and packaging options for St. Cloud clinoptilolite products. Sizing and packaging to customer specifications is also available.

Size	Packaging
3/4×1/2"	Bulk, 50 lb bag, or 1 st supersack
1/2×1/4"	
6×8 mesh	
6×14 mesh	
8×14 mesh	
14×40 mesh	
–40 mesh	
–100 mesh	

TABLE 2—Various physical and chemical properties of St. Cloud clinoptilolite.

Parameter	Value
Acid stability	0–7 (pH)
Alkali stability	7–13 (pH)
Bulk density (solid, dried)	87 lbs/ft <sup>3</sup> 1,390 kg/m <sup>3</sup>
Bulk density (aggregate, dried)	
4×6 mesh	53–57 lbs/ft <sup>3</sup>
6×14 mesh	54–58 lbs/ft <sup>3</sup>
14×40 mesh	62–66 lbs/ft <sup>3</sup> 783–1,054 kg/m <sup>3</sup>
Cation exchange capacity (CEC) (1.2=typical)	1.0–2.2 meq/gm
Color	White 85 optical reflectance
Crushing strength	2,500 lbs/in <sup>3</sup> (176 kg/m <sup>3</sup> )
Hardness	3.5–4.0 Mohs scale
Molecular ratio	4.9 (Si/Al)
Other	Negligible solubility Non-slaking Free-flowing Readily mixable
pH (natural)	8.0 (approx.)
Pore size (diameter)	4.0 Å
Pore volume	15%
Resistivity	9,000 (approx.) ohms/cm
Specific gravity	2.2–2.4
Surface area	40 m <sup>2</sup> /gm
Swelling index	Nil
Thermal stability	1,202°F (650°C)

products, aquarium filters, air filters, soil additives, concrete additives, household odor control, modified clinoptilolites, and waste-water treatment.

Three characteristics of the St. Cloud clinoptilolite make it more favorable for some uses than other natural clinoptilolites now commercially available: (1) it is relatively hard and attrition resistant, making it better suited for concrete additives, turf grasses, spill cleanup and filtration; (2) Cuchillo Negro clinoptilolite is relatively potassium-rich (Table 3), although most clinoptilolites are sodium-rich, which is a benefit in soils where sodium is a toxin to plants, potassium is a nutrient; and (3) laboratory studies have shown that, while St. Cloud clinoptilolite may have a lower theoretical cation exchange capacity than some other clinoptilolite, it performs better in actual test applications, such as ammonia absorption (i.e. reactivity is high).

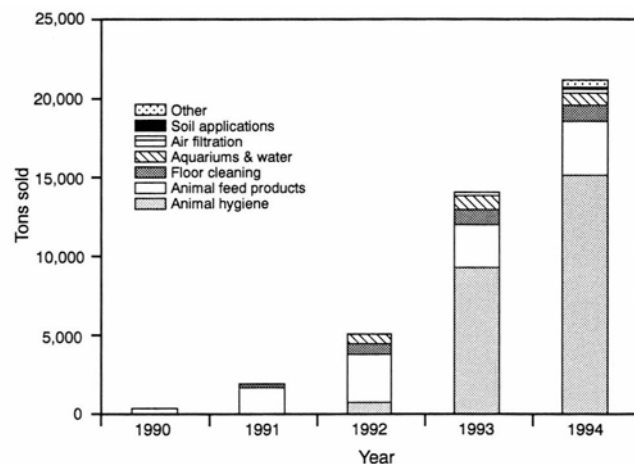

FIGURE 17—Clinoptilolite production by St. Cloud tabulated by end-use categories for the period 1990–1994.

TABLE 3—Mass balance evaluation of unaltered and clinoptilolite altered rocks Cuchillo Negro clinoptilolite, St. Cloud clinoptilolite mine. Numbers in bold represent sample numbers. Analyses by Chris McKee, New Mexico Bureau of Mines and Mineral Resources, using XRF spectrometry. LOI = loss in ignition.

Element	3807	3808	3809	3810
SiO <sub>2</sub>	57.84	63.14	66.14	68.2
TiO <sub>2</sub>	0.6	0.38	0.25	0.2
Al <sub>2</sub> O <sub>3</sub>	13.46	14.02	12.27	11.64
Fe <sub>2</sub> O <sub>3</sub>	3.71	2.4	1.27	1.21
MnO	0.06	0.06	0.06	0.04
MgO	2.33	2.18	1.38	1.32
CaO	6.1	3.16	3.08	2.71
Na <sub>2</sub> O	0.84	0.52	0.42	0.25
K <sub>2</sub> O	2.53	3.24	2.38	3.21
P <sub>2</sub> O <sub>5</sub>	0.19	0.07	0.03	0.02
<b>LOI</b>	<b>12.13</b>	<b>10.64</b>	<b>11.96</b>	<b>10.31</b>
<b>Total</b>	<b>99.79</b>	<b>99.81</b>	<b>99.24</b>	<b>99.11</b>

3807—Relatively unaltered tuffaceous arenite from location about 1,000 ft NE of open pit.

3808—Incipiently altered tuffaceous arenite located about 400 ft south of 3807.

3809—Clinoptilolite altered material from round blasted in St. Cloud pit, collected 5/26/95.

3810—Clinoptilolite altered material from west end lower portion of St. Cloud pit, collected 5/26/95.

#### Acknowledgments

We are grateful to Patrick Freeman, President of St. Cloud Mining Company, and Charles Chapin, Director of the New Mexico Bureau of Mines AND Mineral Resources, for support. Chris McKee provided X-ray analyses of clinoptilolite samples, Kathy Glesener drafted most of the figures, and Terry Telles provided word processing.

#### References

- Bowie, M. R., Barker, J. M., and Peterson, S. L., 1987, Comparison of selected zeolite deposits of Arizona, New Mexico, and Texas; *in* Pierce, W. H. (ed.), Proceedings of the 21st Forum on the Geology of Industrial Minerals: Arizona Bureau of Geology and Mineral Technology, Special Paper 4, pp. 90105.
- Bowie, M. R., and Barker, J. M., 1986, Clinoptilolite west of Cuchillo Negro Creek, New Mexico: New Mexico Geological Society, Guidebook 37, pp. 283-286.
- Harrison, R. W., 1989, Geology of Winston 71/2 minute quadrangle, Sierra County, New Mexico, New Mexico Bureau of Mines and Mineral Resources, Open-file Report 358,17 pp., 2 sheets, scale 1:24,000.
- Harrison, R. W., 1986, General geology of Chloride Mining District, Sierra and Catron Counties, New Mexico: New Mexico Geological Society, Guidebook 37, pp. 265-272.
- Maxwell, C. H., and Heyl, A. V., 1976, Preliminary geologic map of the Winston quadrangle, Sierra County, New Mexico: U.S. Geological Survey, Open-file Report 76-858, 1 sheet, scale 1:24,000.

# Industrial specifications of the Wind Mountain nepheline-syenite deposit, Cornudas Mountains, Otero County, New Mexico

Virginia T. McLemore<sup>1</sup> and James Guilinger<sup>2</sup>

<sup>1</sup>New Mexico Bureau of Mines & Mineral Resources, New Mexico Tech, 801 Leroy Place, Socorro, New Mexico 87801-4796, USA  
<sup>2</sup>Addwest Minerals Inc., 5460 Ward Road, Arvada, Colorado 80002, USA

**Abstract**—The Wind Mountain nepheline-syenite deposit is part of the alkalic complex in the Cornudas Mountains, which ranges in age from  $34.6 \pm 1.5$  Ma to  $36.8 \pm 0.6$  Ma. The Wind Mountain deposit is a complex, zoned pluton that ranges from syenite porphyry to nepheline-syenite porphyry. The deposit has potential use for ceramics and dark-colored beverage containers and consists of nepheline, alkali-feldspar, albite, and varying amounts of other minerals. Analcite is also present locally but must be avoided because it is unsuitable for ceramics and glass. Chemically the deposit consists of 56-63%  $\text{SiO}_2$ , 17-21%  $\text{Al}_2\text{O}_3$ , and 4-5%  $\text{Fe}_2\text{O}_3$ . Although initially iron is initially high, when the crushed rock is passed through a specialized magnetic separator the iron content drops to below commercial maximum standards of less than 0.5%  $\text{Fe}_2\text{O}_3$ . The Wind Mountain deposit is currently undergoing exploration and testing to determine marketability.

## Especificaciones industriales del yacimiento *Wind Mountain* de sienita nefelinica, Montañas Cornudas, Condado de Otero, Nuevo Mexico

**Resumen**—Este yacimiento es parte de un complejo alcalico que varia en edad entre  $34.6 \pm 1.5$  y  $36.8 \pm 0.6$  millones de años. Forma parte de un complejo plutónico zonado que varia en composición desde pórfido sienítico a pórfido nefelino-sienítico. Minerales de este yacimiento son materia prima para uso en cerámica y recipientes oscuros para bebidas. Mineralógicamente, el yacimiento se compone de nefelino, feldespato alcalino, albita y concentraciones variables de otros minerales. Localmente también contiene analcita, pero hay que evitarla porque es perjudicial para cerámica o vidrio. La composición química es de  $\text{SiO}_2$ : 56-63%;  $\text{Al}_2\text{O}_3$ : 17-21% y  $\text{Fe}_2\text{O}_3$ : 5%. Aunque el contenido inicial de hierro es alto, cuando la roca triturada pasa por un separador magnético especial, el contenido de hierro queda reducido por debajo de la tolerancia comercial máxima, que es del 0.5% de  $\text{Fe}_2\text{O}_3$ . En la actualidad, se está explorando este depósito para determinar las posibilidades de comercialización.

### Introduction

The Wind Mountain nepheline-syenite deposit is part of the alkalic complex in the Cornudas Mountains in southern Otero County, New Mexico, and northern Hudspeth County, Texas (Fig. 1). The Cornudas Mountains form part of the northern portion of the Trans-Pecos magmatic province, a regional belt of igneous rocks within an area defined by the Rio Grande on the west and south, the Pecos River on the east, and an east—west line approximately 12 km north of the boundary between New Mexico and Texas (see fig. 2, McLemore et al., this volume). This province contains more than 200 intrusive bodies (Barker, 1977, 1987).

Recently Addwest Minerals Inc. began exploration and development of the nepheline syenite at Wind Mountain for use in amber-colored beverage bottles and ceramics and as roofing granules, abrasives, and dimension stone. Production of nepheline syenite by underground methods is expected to commence within the next few years.

The earliest geologic mapping and petrographic studies of the Cornudas Mountains were by Zapp (1941), Timm (1941), and Clabaugh (1941, 1950). Warner et al. (1959) examined the Wind Mountain area for beryllium and refined the earlier geologic map. Subsequent map-

ping by Addwest Minerals Inc. further refined the geologic map (McLemore and Guilinger, 1993; McLemore et al., this volume; 1996). D. S. Barker, J. G. Price, C. D. Henry, and their colleagues (Barker, 1977, 1979, 1987;

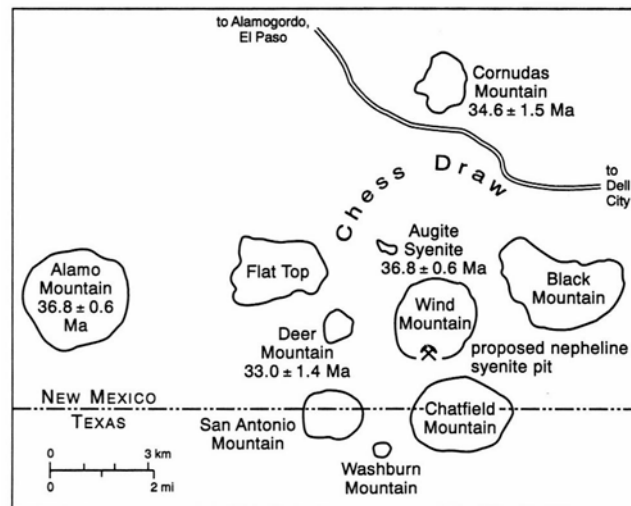

FIGURE 1—Reference map of Cornudas Mountains.



Barker et al., 1977; Barker and Hodges, 1977; Price et al., 1987; Henry et al., 1989, 1991) have examined the petrography, geochemistry, and origin of the Trans-Pecos area, including the Cornudas Mountains. McLemore and Guilinger (1993) and McLemore et al. (this volume; 1996) summarize the geology and mineral resource potential of the Cornudas Mountains.

This paper presents new data on the Wind Mountain nepheline syenite and proposes several potential uses.

### Geology

The Cornudas Mountains consist of a group of late Eocene to Oligocene laccoliths, sills, plugs, and dikes of predominantly nepheline syenite, phonolite, and trachyte (Fig. 1). Age determinations range from  $33.0 \pm 1.4$  (K/Ar on biotite) at Deer Mountain (Barker et al., 1977; Henry et al., 1986) to  $36.8 \pm 0.6$  (K/Ar on biotite) at Alamo Mountain (Barker et al., 1977; Henry et al., 1986). Ten larger intrusive bodies and numerous dikes, sills, and smaller plugs have intruded the relatively flat-lying limestones and other sedimentary rocks of Permian and Cretaceous age. Most of these sedimentary rocks belong to the Hueco Limestone and Bone Springs Limestone.

The larger laccoliths and sills, except for the Cornudas Mountain laccolith, are composed predominantly of dark gray to pink, fine- to coarse-grained to porphyritic nepheline syenites, syenites, and phonolites. The Cornudas Mountain is a deeply weathered and eroded laccolith or plug consisting of light gray to pink-gray quartz syenite to syenite and trachyte (Zapp, 1941; McLemore and Guilinger, 1993; McLemore et al., this volume; 1996).

The laccoliths may be texturally and compositionally zoned because extremely diverse compositions and textures of varying grain size are found within single intrusive bodies. Detailed geologic mapping of possible textural and compositional zones within the laccoliths is hampered by steep terrain, talus-covered slopes, and locally poor outcrops. The Wind Mountain is an excellent example of zoning. A medium-grained nepheline-syenite porphyry forms a rim around a coarse-grained nepheline-syenite porphyry that in turn surrounds a central core of fine-grained syenite porphyry (McLemore et al., this volume; 1996). Younger dikes, some pegmatitic and others aphanitic, intruded many of the laccoliths. Other laccoliths need to be mapped to determine if they too are zoned.

Chemical analyses of igneous rocks from the Cornudas Mountains are given in McLemore and Guilinger (1993) from a variety of sources. These alkalic rocks are similar in composition to other alkalic igneous rocks in the Trans-Pecos magmatic province (Barker et al., 1977; Barker, 1987).

In a regional evaluation program Addwest Minerals Inc. discovered that nepheline syenite from the Wind Mountain is suitable for dark-colored beverage bottles, ceramics, and several other possible uses. The Wind Mountain nepheline syenite is a zoned pluton that ranges from syenite porphyry to nepheline-syenite porphyry. The mineralogy of the deposit is described by McLemore et al. (this volume; 1996). The nepheline syenite at the pit 1 and 2 locations is typical of the type 5 nepheline syenite described by Barker et al. (1977). It has euhedral medium- and coarse-grained potassium feldspars. These alkali-feldspars have very minor exsolution present and are unaltered. They are surrounded by a matrix of plagi-

oclase laths. A crude lineation of these laths around the larger alkali-feldspars is present. Abundant nepheline is interstitial to the feldspars and mafic minerals include mostly biotite, clinopyroxene (aegirine), and arfvedsonite. Accessory minerals include magnetite and apatite. Analcime is also present locally as an alteration of nepheline and feldspar, but must be avoided in commercial deposits because it inhibits the fusion required to produce glass and ceramics. Chemically, the deposit consists of 56-63% SiO<sub>2</sub>, 17-21% Al<sub>2</sub>O<sub>3</sub>, and 4-5% Fe<sub>2</sub>O<sub>3</sub> (Table 1). Although iron is initially high, when the crushed rock is passed through a specialized rare-earth-element magnetic separator the iron content drops below commercial maximum standards of less than 0.5% Fe<sub>2</sub>O<sub>3</sub> (Table 2). Preliminary examination of other intrusives in the Cornudas Mountains failed to locate any additional nepheline-syenite deposits suitable for glass and ceramic use. Additional studies are underway.

### Uses

Nepheline syenite is a critical ingredient in manufacturing glass and ceramics. There are only two commercial deposits of nepheline syenite in the world, in Canada and Norway (Potter, 1991), and they average more than 60% SiO<sub>2</sub>, 20-24% Al<sub>2</sub>O<sub>3</sub>, and less than 0.1% Fe<sub>2</sub>O<sub>3</sub>. The Soviet Union has produced nepheline syenite in the past (Lofty et al., 1991). Because too much iron results in colored glass or ceramics, the product obtained from a commercial deposit should contain as little iron-bearing minerals as possible. Nepheline syenite also imparts the unique quality of toughness, making the glass more resistant to breakage.

Some other uses of nepheline syenite include filler applications, roofing granules, dimension stone, aggregate, and an abrasive. As roofing granules, nepheline syenite's UV attenuation characteristics are such that it blocks sunlight from degrading an asphalt roof, making the rock a viable substitute for the currently used boiler slag. The medium- to coarse-grained texture, ability to take a polish, and the unique beauty make the rock desirable as a dimension stone. Nepheline syenite is fairly tough, silica-free, and chemically inert, which allows for use as an abrasive. The fact that nepheline syenite is silica-free gives it a significant marketing advantage, because more and more states are banning the use of silica-based sandblast media.

### Marketing and processing

The Wind Mountain nepheline syenite has been tested for various uses and found to meet manufacturer's specifications for dark-colored beverage containers (glass) and ceramics (Table 2), roofing granules (Table 3), dimension stone (Table 4), aggregate (Table 5), and abrasive material (Table 6). The nepheline syenite will be quarried, processed, and trucked to El Paso, Texas. All processing will be dry. Magnetic separation of crushed material will be utilized for reduction of iron minerals to achieve glass and ceramic specifications (Table 2). Products can be shipped from El Paso by truck or rail. Total reserves are estimated at 200 million short tons, which will enable flexibility to meet any production level well into the foreseeable future.

### Conclusion

When crushed and passed through a specialized magnetic separator, the Wind Mountain nepheline syenite



TABLE 1—Chemical analyses of the outermost ore zone at Wind Mountain. Major elements are calculated as percent and trace elements are calculated in parts per million. Samples collected by V. T. McLemore or J. R. Guilinger. Pit 1 and Pit 2 are analyses of the nonmagnetic fraction only. Fe<sub>2</sub>O<sub>3</sub>\* is total iron calculated as Fe<sub>2</sub>O<sub>3</sub>. Description of samples in Appendix 1.

	CORN10 <sup>1</sup>	CORN14 <sup>1</sup>	CORN18 <sup>1</sup>	CORN15 <sup>1</sup>	TSPFG <sub>2</sub> <sup>1</sup>	TNSP <sub>1</sub> <sup>1</sup>	TNSP <sub>2</sub> <sup>2</sup>	PIT 1 <sup>2</sup>	PIT 2 <sup>2</sup>
SiO <sub>2</sub>	59.10	61.70	58.20	58.00	58.80	56.30	63.30	64.70	63.80
TiO <sub>2</sub>	0.14	0.25	0.26	0.44	0.12	0.08	0.03	<0.01	<0.01
Al <sub>2</sub> O <sub>3</sub>	17.60	18.90	17.90	19.90	18.20	18.70	20.80	20.50	20.90
Fe <sub>2</sub> O <sub>3</sub> *	5.61	4.70	4.68	4.16	6.24	6.43	1.54	0.52	0.40
MgO	0.48	1.80	0.44	1.04	0.81	0.47	0.07	<0.05	<0.05
CaO	1.10	1.64	1.37	1.92	1.35	1.40	0.68	0.23	0.20
K <sub>2</sub> O	5.06	5.27	4.86	5.74	5.30	4.80	6.32	6.74	6.73
Na <sub>2</sub> O	7.44	7.20	9.76	7.29	8.12	8.80	7.53	7.62	8.23
MnO	0.28	0.24	0.35	0.13	0.35	0.33	0.14	<0.01	<0.01
P <sub>2</sub> O <sub>3</sub>	0.11	0.16	0.10	0.15	0.10	0.04	<0.05	<0.05	<0.05
LOI	1.75	1.51	2.08	2.11	2.80	2.91	—	—	—
TOTAL	98.67	103.37	100.00	100.88	102.19	100.26	100.41	100.31	100.26
Pb	—	—	50	—	50	40	45	23	25
Th	—	—	78	—	63	41	46	43	41
Rb	—	—	258	—	185	235	176	180	168
U	—	—	11	—	14	11	25	26	23
Sr	—	—	111	—	59	230	46	37	36
Y	—	—	103	—	67	150	55	34	39
Zr	—	—	2155	—	2296	3965	645	338	322
Nb	—	—	448	—	310	45	89	57	67
Mo	—	—	11	—	11	10	<10	<10	<10
Ga	39	28	44	—	38	49	—	—	—
Zn	264	73	334	—	285	277	105	60	78
Cu	5	4	3	—	7	11	<10	<10	<10
Ni	10	8	10	—	182	173	<10	<10	<10
Na <sub>2</sub> O+K <sub>2</sub> O	12.50	12.47	14.62	13.03	13.42	13.60	13.85	14.36	14.96

<sup>1</sup>Analyzed by C. McKee (NMBMMR, X-ray Laboratory);

<sup>2</sup>Analyzed by The Mineral Lab Inc.

TABLE 2—Product specifications of Wind Mountain nepheline syenite after processing for use as glass-grade and ceramic-grade materials.

Element (%)	Chemical analysis	
	Average	Range
SiO <sub>2</sub>	63.0	61.4–64.7
Al <sub>2</sub> O <sub>3</sub>	20.5	20.1–20.9
Fe <sub>2</sub> O <sub>3</sub>	0.44	0.40–0.52
CaO	0.20	0.18–0.23
MgO	trace	—
K <sub>2</sub> O	6.60	6.40–6.74
Na <sub>2</sub> O	8.14	7.62–8.40
Cr	not detectable	—
TiO <sub>2</sub>	trace	—
Ignition loss	2.13	—
Physical analysis		
Glass-grade materials (wt.% retained)	Ceramic-grade materials (wt.% retained)	
16 mesh	0	<200 mesh product
20 mesh	0	+140 mesh 0.5
30 mesh	0	+200 mesh 1.5
40 mesh	4.0	+325 mesh 10.0
+100 mesh	66.0	pan 88.0
+200 mesh	20.0	
-200 mesh	10.0	
		<325 mesh product
		140 mesh trace
		+200 mesh 0.3%
		+325 mesh 5.0%
		pan 94.7%

TABLE 3—Test results of Wind Mountain nepheline syenite for use as roofing granules.

Test	Method	Standard minimum value	Wind Mountain
UV attenuation (lbs/ft <sup>3</sup> )	ASTM D-5081, Hiding power	No limits	3.07
Bulk density (lbs/ft <sup>3</sup> )	Loose	75	70
Free silica as SiO <sub>2</sub>	Petrographic examination	None	None

TABLE 4—Test results of Wind Mountain nepheline syenite for use as dimension stone (by CTL Thompson Laboratory).

Test	Method	Standard minimum value	Wind Mountain
Density (lbs/ft <sup>3</sup> )	ASTM C-97	160	162
Modulus of rupture (psi)	ASTM C-99	1500	2375
Flexural strength (psi)	ASTM C-880	1200	1615
Abrasion resistance	ASTM C-241	12	56
Compressive strength (psi)	ASTM C-170	19	35

TABLE 5—Test results of Wind Mountain nepheline syenite for use as aggregate (by CTL Thompson Laboratory).

Test	Method	Standard minimum value	Wind Mountain
LA abrasion (%)	ASTM C-131	50	30
Specific gravity	ASTM C-127	No limits	2.52
Adsorption (%)	ASTM C-127	No limits	1.8
Lightweight pieces (%)	ASTM C-123	0.5	None
Clay/friable particle (%)	ASTM C-142	2.0	0.49
Sodium soundness	ASTM C-88	-12	-1.15
Potential reactivity	ASTM C-289	No reaction	No reaction
DOT highway const. suitability	ASTM C-33	Suitable	Suitable

TABLE 6—Test results of Wind Mountain nepheline syenite for use as an abrasive (Addwest Minerals Inc. data from various laboratories). LOI=loss on ignition.

Test	Method	Standard minimum value (mg/L)	Wind Mountain (mg/L)
<i>Toxicity leach (TCLP)</i>			
As	EPA-206.4	5.0	<0.2
Ba	SW846-6010	100	<0.3
Cd	SW846-7130	1.0	<0.03
Cr	SW846-7190	5.0	<0.05
Pb	SW846-7420	5.0	<0.3
Hg	SW835-7470	0.2	<0.001
Se	SW846-7740	1.0	<0.03
Ag	SW846-7760	5.0	<0.05
<i>California hazardous waste (STLC)</i>			
Sb	SW846-6010	15	<0.09
As	EPA 206.4	5.0	<0.03
Ba	SW846-6010	100	1.1
Be	SW846-6010	0.75	<0.02
Cd	SW846-7130	1.0	<0.05
Cr VI	SW846-7196	5.0	0.05
Cr	SW846-7190	560	<0.1
Co	SW846-7200	80	<0.04
Cu	SW846-7210	25	<0.04
F	EPA 340.2	180	0.98
Pb	SW846-7420	5.0	<0.5
Hg	SW846-7470	0.2	<0.001
Mo	SW846-6010	350	<0.04
Ni	SW846-7520	20	<0.04
Se	SW846-7740	1.0	0.20
Ag	SW846-7760	5.0	<0.01
Th	SW846-6010	7.0	<0.4
V	SW846-7950	24	0.04
Zn	SW846-7950	250	0.78
<i>California hazardous waste-total elements</i>			
Sb	CAC-22-4-II-66700	0.05	<0.005
As	CAC-22-4-II-66700	0.05	<0.0004
Ba	CAC-22-4-II-66700	1.0	<0.005
Be	CAC-22-4-II-66700	0.0075	0.0006
Cd	CAC-22-4-II-66700	0.01	<0.0005
Cr VI	CAC-22-4-II-66700	0.05	<0.005
Cr	CAC-22-4-II-66700	0.25	<0.001
Co	CAC-22-4-II-66700	0.80	<0.001
Cu	CAC-22-4-II-66700	0.25	<0.001
F	CAC-22-4-II-66700	1.80	0.05
Pb	CAC-22-4-II-66700	0.10	0.003
Hg	CAC-22-4-II-66700	0.002	<0.00001
Mo	CAC-22-4-II-66700	0.35	<0.005
Ni	CAC-22-4-II-66700	0.10	<0.001
Se	CAC-22-4-II-66700	0.01	<0.0001
Ag	CAC-22-4-II-66700	0.05	<0.001
Th	CAC-22-4-II-66700	0.07	<0.005
V	CAC-22-4-II-66700	0.24	<0.001
Zn	CAC-22-4-II-66700	0.50	0.010

meets specifications for use in manufacture of dark-colored beverage containers and ceramics. In addition, the Wind Mountain nepheline syenite is suitable for roofing granules, dimension stone, aggregate, and abrasive material. Reserves are estimated at or in use excess of 200 million st. Production is expected within a few years. Additional geologic studies to increase reserves and additional testing to expand market potential are underway.

#### Acknowledgments

Special thanks are due to P. Gruaseah for his geologic map of Wind Mountain. Figures were drafted by the NMBMMR Cartography Department and the manuscript was typed by Lynne Hemenway and Terry Telles. This

TABLE 6—Continued

Test	Method	Standard minimum value (mg/L)	Wind Mountain (mg/L)
<i>Others</i>			
Moisture	MIL-A-22262B (SH)	0.5	0.14
LOI 1000° C	MIL-A-22262B (SH)	+5.0	-0.70
Cl	MIL-A-22262B (SH)	0.03	0.003
Free flow	MIL-A-22262B (SH)		99.7
Clumping	MIL-A-22262B (SH)		None
Free silica as SiO <sub>2</sub>	MIL-A-22262B (SH)	1.0	0.4
Free silica as SiO <sub>2</sub>	MIL-A-22262B (SH)	1.0	Not det.
Free silica as SiO <sub>2</sub>	XRD	1.0	Not det.
Specific gravity	MIL-A-22262B (SH)		2.7
Carbonates	MIL-A-22262B (SH)		None
Conductivity	MIL-A-22262B (SH)	100	13.4
Oil	MIL-A-22262B (SH)	0.03	0.0045
Gross gamma pCi/g	MIL-A-22262B (SH)	10	9.3
Co 60 pCi/g	MIL-A-22262B (SH)	0.02	0.00
Moh's hardness	MIL-A-22262B (SH)		>6
Shape	MIL-A-22262B (SH)		Angular

work was supported by NMBMMR (Charles E. Chapin, Director and State Geologist) and Addwest Minerals Inc. (James R. Guilinger, project supervisor).

#### References

- Barker, D. S., 1977, Northern Trans-Pecos magmatic province: Introduction and comparison with the Kenya rift: Geological Society of America Bulletin, v. 88, pp. 1421-1427.
- Barker, D. S., 1979, Cenozoic magmatism in the Trans-Pecos province: Relation to Rio Grande rift; *in* Riecker, R. E. (ed.), Rio Grande rift: Tectonics and magmatism: American Geophysical Union, pp. 382-392.
- Barker, D. S., 1987, Tertiary alkaline magmatism in Trans-Pecos Texas; *in* Fitton, J. G., and Upton, B. G. J. (eds.), Alkaline igneous rocks: The Geological Society (U.K.), Special Publication 30, pp. 415-431.
- Barker, D. S., and Hodges, F. N., 1977, Mineralogy of intrusions in the Diablo Plateau, northern Trans-Pecos magmatic province, Texas and New Mexico: Geological Society of America Bulletin, v. 88, pp. 1428-1436.
- Barker, D. S., Long, L. E., Hoops, C. K., and Hodges, F. N., 1977, Petrology and Rb-Sr isotope geochemistry of intrusions in the Diablo Plateau, northern Trans-Pecos magmatic province, Texas and New Mexico: Geological Society of America Bulletin, v. 88, pp. 1437-1446.
- Clabaugh, S. E., 1941, Geology of the northwestern portion of the Cornudas Mountains, New Mexico: Unpublished MS thesis, University of Texas (Austin), 66 pp.
- Clabaugh, S. E., 1950, Endialyte and eucolite from southern New Mexico (abs.): American Mineralogist, v. 35, pp. 279-280.
- Henry, C. D., McDowell, F. W., Price, J. G., and Smyth, R. C., 1986, Compilation of potassium-argon ages of Tertiary igneous rocks, Trans-Pecos Texas: University of Texas (Austin), Bureau of Economic Geology, Geological Circular 86-2, pp. 6-7.
- Henry, C. D., Price, J. G., and James, E. W., 1991, Mid-Cenozoic stress evolution and magmatism in the southern Cordillera, Texas and Mexico: Transition from continental arc to intraplate extension: Journal of Geophysical Research, v. 96, no. B8, pp. 13,545-13,560.
- Henry, C. D., Price, J. G., Parker, D. F., and Wolff, J. A., 1989, Excursion 9A: Mid-Tertiary silicic alkaline magmatism of Trans-Pecos Texas rheomorphic tuffs and extensive silicic lavas; *in* Chapin, C. E., and Zidek, J. (eds.), Field excursions to volcanic terranes in the western United States, Volume 1: Southern Rocky Mountain region: New Mexico Bureau of Mines and Mineral Resources, Memoir 46, pp. 231-274.
- Lofty, G. J., Hillier, J. A., Sooke, S. A., Hale, P. I., Linley, K. A. and Singh, H. R. (compilers), 1991, World mineral statistics 1985-89: Geological Survey of United Kingdom, Keyworth, Nottingham, p. 307.
- McLemore, V. T., and Guilinger, J. R., 1993, Geology and mineral resources of the Cornudas Mountains, Otero County, New Mexico and Hudspeth County, Texas: New Mexico Geological Society, Guidebook 44, pp. 145-153.
- McLemore, V. T., Lueth, V. W., Guilinger, J. R., and Pease, T. C., this volume, Geology, mineral resources, and marketing of the Wind Mountain nepheline-syenite porphyry, Cornudas Mountains, New Mexico and Texas: New Mexico Bureau of Mines and Mineral Resources, Bulletin 154.
- McLemore, V. T., Lueth, V. W., Pease, T. C., and Guilinger, J. R., 1996, Petrology and mineral resources of the Wind Mountain laccolith, Cornudas Mountains, New Mexico and Texas: Canadian Mineralogist v.34, in press.
- Potter, M. J., 1990, Annual report of feldspar, nepheline syenite and aplite: U.S. Bureau of Mines, 6 pp.
- Price, J. G., Henry, C. D., Barker, D. S., and Parker, D. F., 1987, Alkalic rocks of contrasting tectonic settings in Trans-Pecos Texas; *in* Mantle metasomatism and alkaline magmatism: Geological Society of America, Special Paper 215, pp. 335-346.
- Timm, B. C., 1941, The geology of the southern Cornudas Mountains, Texas and New Mexico: Unpublished MS thesis, University of Texas (Austin), 55 pp.
- Warner, L. A., Holser, W. T., Wilmarth, V. R., and Cameron, E. N., 1959, Occurrence of nonpegmatite beryllium in the United States: U.S. Geological Survey, Professional Paper 318, 198 pp.
- Zapp, A. D., 1941, Geology of the northeastern Cornudas Mountains, New Mexico: Unpublished MS thesis, University of Texas (Austin), 63 pp.

#### Appendix 1-Description of samples

CORN-10	Nepheline syenite, TSNP <sub>1</sub> , Wind Mountain
CORN-14	Nepheline syenite, TSNP <sub>2</sub> , Wind Mountain
CORN-15	Altered nepheline syenite, TSNP <sub>2</sub> , Wind Mountain
CORN-18	Phonolite dike, NW Wind Mountain
F2TSPFG2	Core sample nepheline syenite TSNP <sub>2</sub> , Wind Mountain
FSTNSD	Core sample nepheline syenite TSNP <sub>2</sub> , Wind Mountain
TSNP <sub>2</sub>	Nepheline syenite, Wind Mountain
PIT 1	Nonmagnetic separate
PIT 2	Nonmagnetic separate



# Geology, mineral resources, and marketing of the Wind Mountain nepheline-syenite porphyry, Cornudas Mountains, New Mexico and Texas

Virginia T. McLemore<sup>1</sup>, Virgil W. Lueth<sup>1</sup>, James R. Guilinger<sup>2</sup>, and Tim C. Pease<sup>3</sup>

<sup>1</sup>New Mexico Bureau of Mines & Mineral Resources, New Mexico Tech, 801 Leroy Place, Socorro, New Mexico 87801-4796, USA

<sup>2</sup>Addwest Minerals Inc., 5460 Ward Road, Suite 370, Arvada, Colorado 80002, USA

<sup>3</sup>Department of Earth and Environmental Science, New Mexico Tech, 801 Leroy Place, Socorro, New Mexico 87801-4796, USA

**Abstract**—The Wind Mountain nepheline syenite is one of 10 laccoliths and stocks in the Cornudas Mountains that form part of the northern Trans-Pecos alkaline magmatic province in southern New Mexico and southwestern Texas. Wind Mountain is texturally and mineralogically zoned and consists of two textural varieties of nepheline-syenite porphyry and four textural varieties of syenite porphyry. The area has been examined for potential economic deposits of gold, silver, beryllium, rare-earth elements, niobium, uranium, and zirconium, but no production has occurred. Recently Addwest Minerals Inc. began exploration and development of the Wind Mountain nepheline-syenite porphyry for use in dark-colored glass, flatglass, and ceramics. The Wind Mountain nepheline syenite is initially high in iron, but when crushed and passed through a specialized rare-earth element magnet the resulting product is similar in composition to Grade B product specified by Unimin Canada Ltd. The magnetic fraction can be sold as millite, an iron-rich additive required for controlling the color of glass. Several other consumers have tested the nepheline syenite and found it suitable for use in ceramics, fiberglass, and flatglass. Other potential uses include silica-free abrasives, roofing granules, and dimension stone. Production, by underground methods, is expected within the next few years.

## Geología, recursos minerales y comercialización del pórfido de sienita nefelinica de Wind Mountain, Montañas Cornudas, Nuevo Mexico y Texas

**Resumen**—La sienita nefelinica de *Wind Mountain* forma uno de diez lacolitos y chimeneas volcánicas en la provincia magmática alcalina de Trans-Pecos norte, en el sur de Nuevo México y el suroeste de Texas. En el lacolito de *Wind Mountain* se distinguen zonas texturales y mineralógicas, a saber, dos variedades texturales de pórfido de sienita nefelinica y cuatro variedades de pórfido sienítico. El área ha sido cateada en busca de yacimientos de oro, plata, berilo, tierras raras, niobio, uranio y circonio, sin que se haya llegado a la exploración comercial. Hace poco, la empresa *Addwest Minerals Inc.* ha comenzado la exploración y desarrollo minero de la sienita nefelinica para uso en la fabricación de vidrio oscuro, vidrio plano (*flatglass*) y cerámica. El material de bocamina tiene alto contenido de hierro, pero una vez molido y pasado por un separador magnético especial para las tierras raras, el mineral resulta similar en composición al producto de Grado B especificado por *Unimin Canada Ltd.* Se puede vender la fracción magnética como *millite*, un aditivo que se usa para controlar el color del vidrio. Ha habido otros interesados que han hecho ensayos con la sienita nefelinica y la han hallado satisfactoria para uso en la fabricación de cerámica, vidrio fibroso (*fiberglass*) y vidrio plano. Otras aplicaciones con promesa son abrasivos fibres de silice, gránulos para techumbre y piedras cortadas de construcción (*dimension stone*). Es inminente el comienzo de la extracción subterránea.

### Introduction

Wind Mountain is one of 10 intrusives in the Cornudas Mountains that stand above the Otero and Diablo Plateaus in southern New Mexico and southwestern Texas (Fig. 1). They form the northern border of the Trans-Pecos alkaline magmatic province. The Cornudas Mountains have been examined for potential deposits of gold, silver, beryllium, rare-earth elements, niobium, and uranium (McLemore and Guilinger, 1993), but there has been no production. Recently Addwest Minerals Inc. began exploration and development of the Wind Mountain nepheline syenite in the Cornudas Mountains for use in manufacturing amber-colored beverage containers, flat

ware, and ceramics and for use as an abrasive and as roofing granules. Production of nepheline syenite by underground methods is expedited within the next few years. The material will be crushed on site, trucked to El Paso, and processed.

During examination of the Wind Mountain nepheline syenite, geologists of Addwest Minerals Inc. found that the Wind Mountain nepheline syenite is texturally and mineralogically zoned (McLemore and Guilinger, 1993, this volume; McLemore et al., 1996). The intrusives of Cornudas Mountains were originally mapped in the early 1940s and 1950s as homogeneous bodies (Zapp, 1941; Timm, 1941; Clabaugh, 1941; Warner et al., 1959).

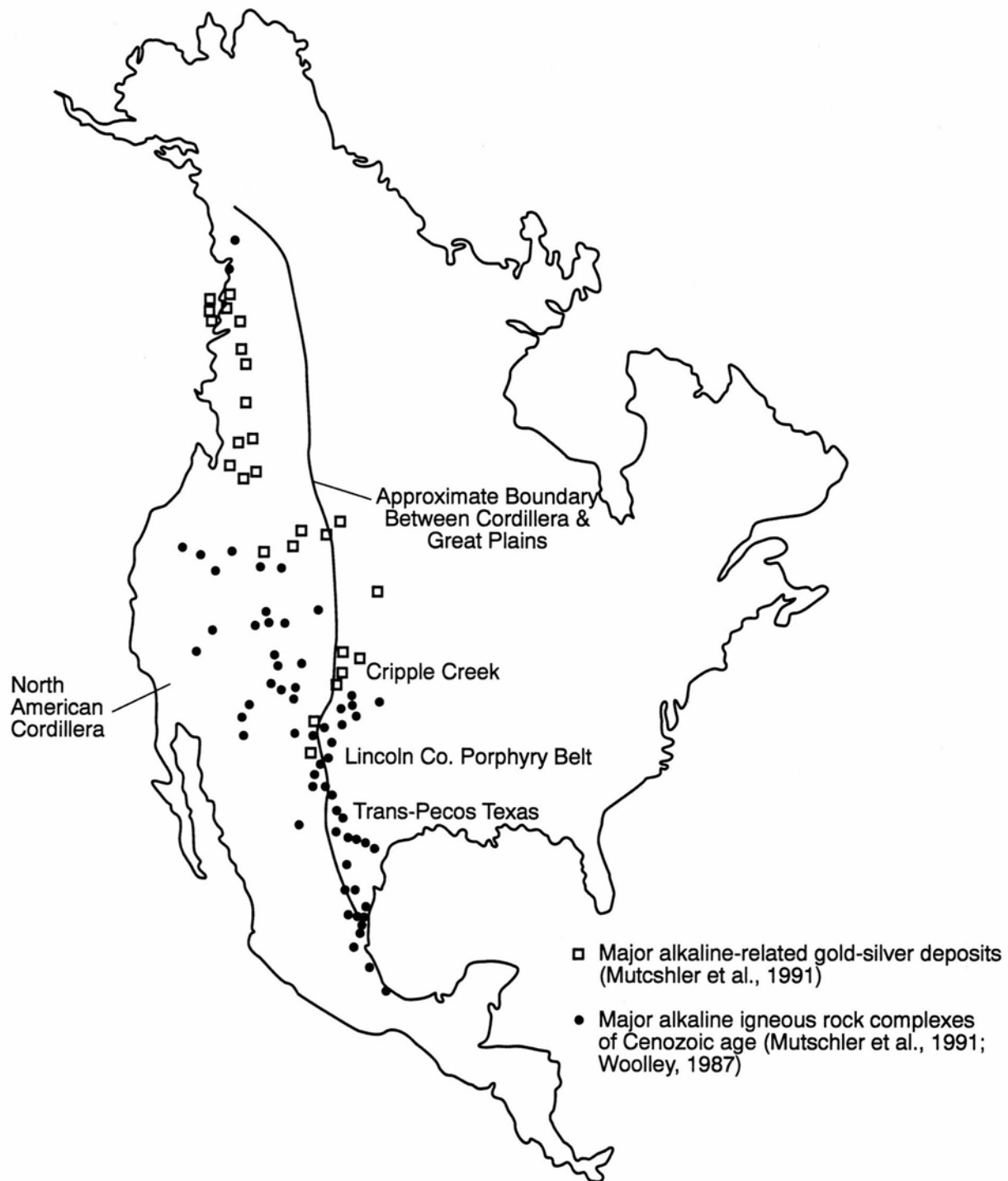

FIGURE 1—North American Cordilleran belt of alkaalic igneous rocks (Woolley, 1987 and Mutschler et al., 1991).

The purpose of this paper is to (1) summarize the petrology and mineralogy of the Cornudas Mountains, (2) describe the mineral-resource potential, and (3) discuss the marketing of the nepheline syenite. The preceding paper describes the uses and industrial specifications in more detail (McLemore and Guilingler, this volume).

#### Regional Setting

The Cornudas Mountains and the Trans-Pecos alkaline magmatic province form part of the southern portion of the North American Cordilleran alkaalic igneous belt (Fig. 1). This belt is a diffuse region of Cenozoic igneous rocks

that extends along the eastern margin of the North American Cordillera from Alaska and British Columbia southward into Trans-Pecos Texas and eastern Mexico (Fig. 2; Barker, 1987; Mutschler et al., 1985, 1991; Woolley, 1987; McLemore, in press).

The Trans-Pecos magmatic province is a regional belt of alkaline and metaluminous igneous rocks that lies within an area defined by the Rio Grande on the west and south, the Pecos River on the east, and an east—west line approximately 12 km north of the state boundary between New Mexico and Texas (Fig. 3). The province contains more than 200 intrusive bodies, each with an

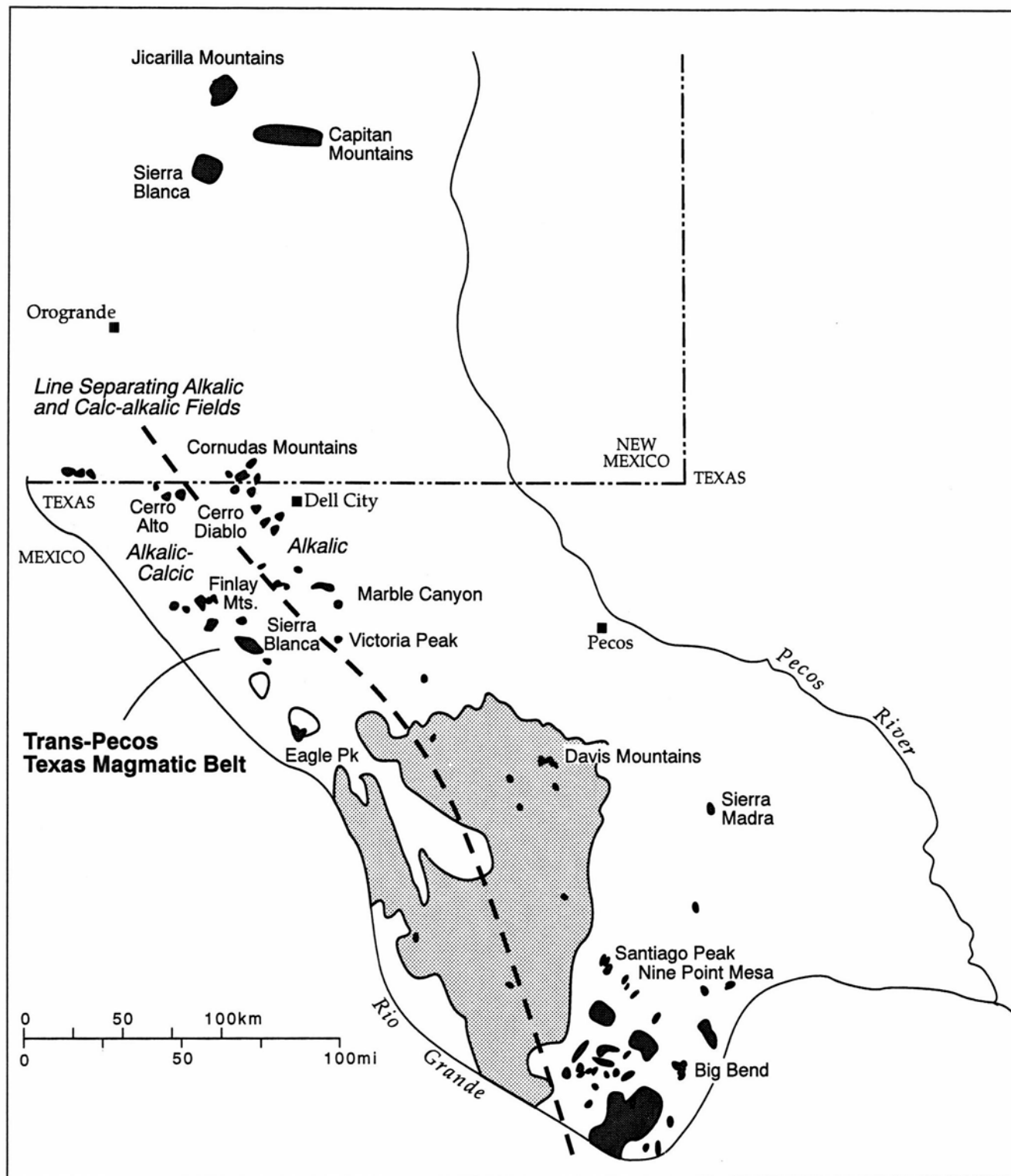

FIGURE 2—Trans-Pecos magmatic province, New Mexico and Texas (modified from Barker, 1987 and Price et al., 1987).

outcrop area exceeding 1 km<sup>2</sup> (Barker, 1977, 1979, 1987). The Trans-Pecos magmatic province is the eastern limit of Cenozoic magmatic activity in southwestern United States and Mexico, which has occurred in the area nearly continuously from 48 to 17 Ma (Henry et al., 1986; Price et al., 1987; Potter, 1994). Compositions of igneous rocks vary from alkaline in the eastern portions of the province, including the Cornudas Mountains, to calc-alkaline westward into Mexico (Fig. 3; Barker et al., 1977; Barker,

1987; Price and Henry, 1984; Cameron and Cameron, 1985; Price et al., 1987; Clark, 1989; Potter, 1994).

Early genetic interpretations suggested an analogy between the Trans-Pecos province and the Kenya portion of the East African rift (Barker, 1977). However, subsequent work has shown that much of Cenozoic faulting in Trans-Pecos Texas thought to be associated with rifting actually post-dates igneous activity (Barker, 1987; Henry et al., 1991). Trans-Pecos magmatic activity began at the



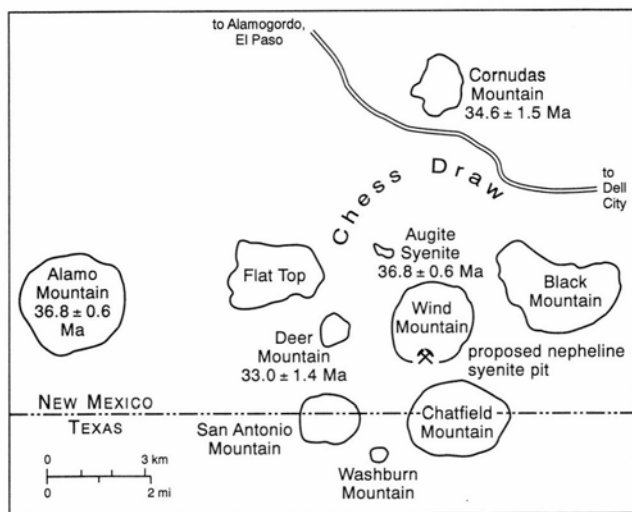

FIGURE 3—Reference map of Cornudas Mountains.

end of the Laramide compressional tectonic period and may be linked to progressive shallowing of the subduction of the Farallon plate beneath the North American plate with time (Coney, 1972; Sillitoe, 1972; Barker, 1987; Damon et al., 1981; Campa and Coney, 1983; Henry et al., 1989, 1991). Chemically the Wind Mountain laccolith is similar to Within-Plate Granite using the classification of Pearce et al., 1984 (McLemore et al., 1996). This suggests that some Trans-Pecos magmatic activity may be related to back-arc spreading (Barker, 1987; McLemore et al., 1996).

### Geology

The Cornudas Mountains consist of 10 larger sills, plugs, and laccoliths (Fig. 2) and smaller dikes and plugs that intrude relatively flat-lying limestones and other sedimentary rocks of the Hueco Limestone and Bone Spring Limestone (Permian). Other dikes, sills, and plugs are buried by sedimentary cover, as is indicated by subsurface drilling (King and Harder, 1985), geophysical surveys, and structural anomalies (i.e. folds, synclines, faults) in the overlying sedimentary rocks. Wind Mountain is one of the largest intrusives with an approximate diameter of 2.5 km.

Barker et al. (1977) divided the lithologies found in the Trans-Pecos magmatic province into nine types based on mineralogy and texture: (1) nepheline-bearing augite syenite, (2) nepheline-bearing trachyte, (3) syenite, (4) nepheline syenite, (5) porphyritic nepheline syenite, (6) phonolite, (7) foliated porphyritic nepheline syenite, (8) quartz-bearing syenite, and (9) quartz-bearing trachyte. All nine types are found in the Cornudas Mountains, but the predominant lithology is nepheline syenite. The larger laccoliths consist of dark gray to pink, fine- to coarse-grained to porphyritic nepheline syenite. The San Antonio Mountain and Wind Mountain laccoliths are mineralogically and texturally zoned, but only the Wind Mountain laccolith has been mapped (Fig. 4; McLemore and Guilinger, 1993).

### Wind Mountain laccolith

#### Geology and petrology

The Wind Mountain laccolith consists of six mineral and textural zones (Figs. 4, 5; McLemore et al., 1996). The

laccolith is typically gray to cream-colored and weathers to darker colors. Accessory minerals form dark-colored aggregates dispersed throughout the rock. The margin of the laccolith is foliated. The foliation dips steeply away from the center of the intrusive body.

The outermost zone consists of medium-grained nepheline-syenite porphyry (TNSP2) which is composed of alkali-feldspar phenocrysts (up to 2 cm long) in a fine- to medium-grained matrix (less than 0.5 cm) of predominantly alkali-feldspar and interstitial nepheline with minor analcite. Accessory minerals form dark-colored aggregates (less than 0.5 cm long) and include aegirine, sodic amphibole, biotite, and magnetite (Fig. 6). The outer nepheline-syenite porphyry (TNSP2) grades into a coarse-grained nepheline-syenite porphyry (TNSP1) which consists of larger and more abundant alkali-feldspar phenocrysts (up to 3 cm) in a coarse-grained matrix (0.5-3 cm) of predominantly alkali-feldspar and interstitial nepheline and minor analcite.

TNSP1 grades into syenite porphyry (TSPfg<sub>4</sub>; Fig. 4) consisting of K-feldspar phenocrysts (up to 1 cm long) in a fine-grained matrix of albite, alkali-feldspar, and interstitial analcite. This syenite porphyry is typically darker gray or cream than the lighter gray or cream nepheline-syenite porphyry (TNSP<sub>1</sub>, TNSP<sub>2</sub>; Fig. 4). TSPfg<sub>4</sub> grades into a more mafic syenite porphyry (TSPfg<sub>3</sub>). Several thin, discontinuous zones of less mafic, lighter-colored, fine-grained syenite porphyry (TSPfg<sub>2</sub>) occur within the mafic syenite porphyry (TSPfg<sub>3</sub>). TSPfg<sub>3</sub> grades into the uppermost cap of syenite porphyry (TSPfg<sub>1</sub>). The syenite porphyry is similar to TSPfg<sub>4</sub> and consists of alkali feldspar phenocrysts (up to 1 cm long) in a fine-grained matrix of predominantly alkali-feldspar and albite with accessory soda amphibole, biotite, and magnetite (Fig. 7). The Wind Mountain laccolith is cut by two dikes of porphyritic phonolite that coalesce into one dike. Eudialite occurs locally in these dikes (Zapp, 1941; Clabaugh, 1950; Warner et al., 1959). Several thin dikes and sills of nepheline-syenite porphyry intrude along bedding planes and fractures in the Permian limestone. Thin zones of chlorite-epidote hornfels are developed locally along the contacts (McLemore and Guilinger, 1993).

### Chemistry

Chemical variations among the individual map units within the laccolith cannot be readily discerned by utilizing major-element analyses (McLemore et al., 1996). However, significant chemical differences in Ba and Sr between the nepheline syenite and syenite units are observed; the syenites contain more Ba and Sr than the nepheline syenites (McLemore et al., 1996). These chemical analyses of the Wind Mountain laccolith suggest that the zonation is controlled by crystal fractionation, volatile separation, and cooling history rather than by different pulses of magma (McLemore et al., 1996). Feldspar crystallization under initially subsolvus conditions can account for most of the variations in the zones (Fig. 5). The feldspar-rich solid forms at or migrates towards the top of the magma chamber and forms a capping syenite. Differential cooling of the magma resulted in the textural variations at Wind Mountain.

The mineralogy is summarized in Table 1. Chemical analyses of the various zones are in McLemore et al. (1996). Average chemical composition of the outer zone (TNSP2) is in Table 2. A list of rare and unusual minerals is in Table 3. A schematic cross section is in Figure 5.

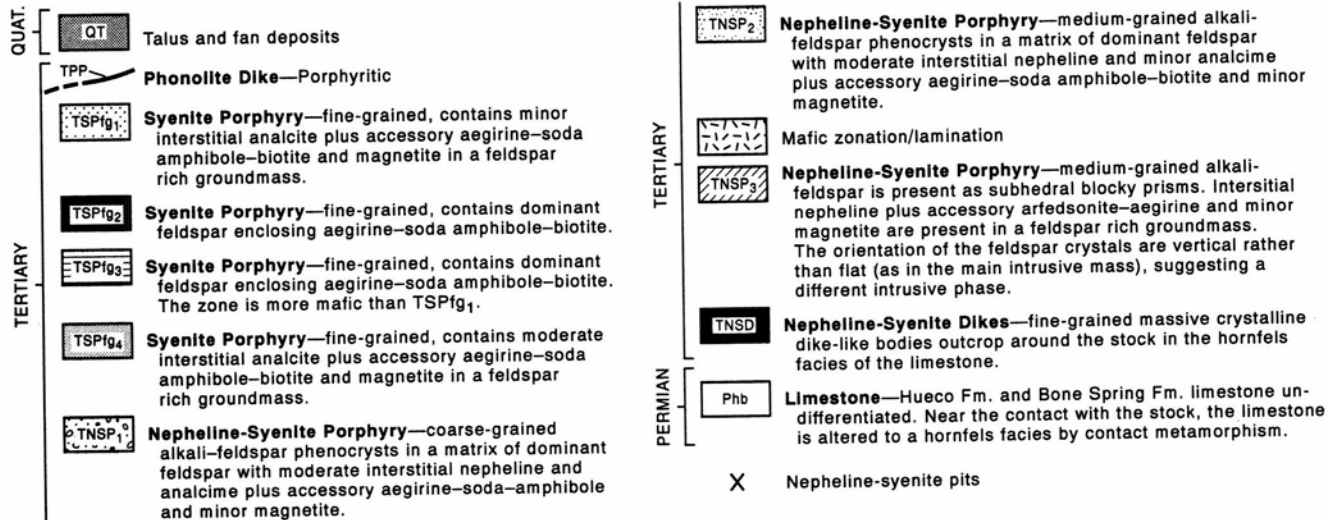
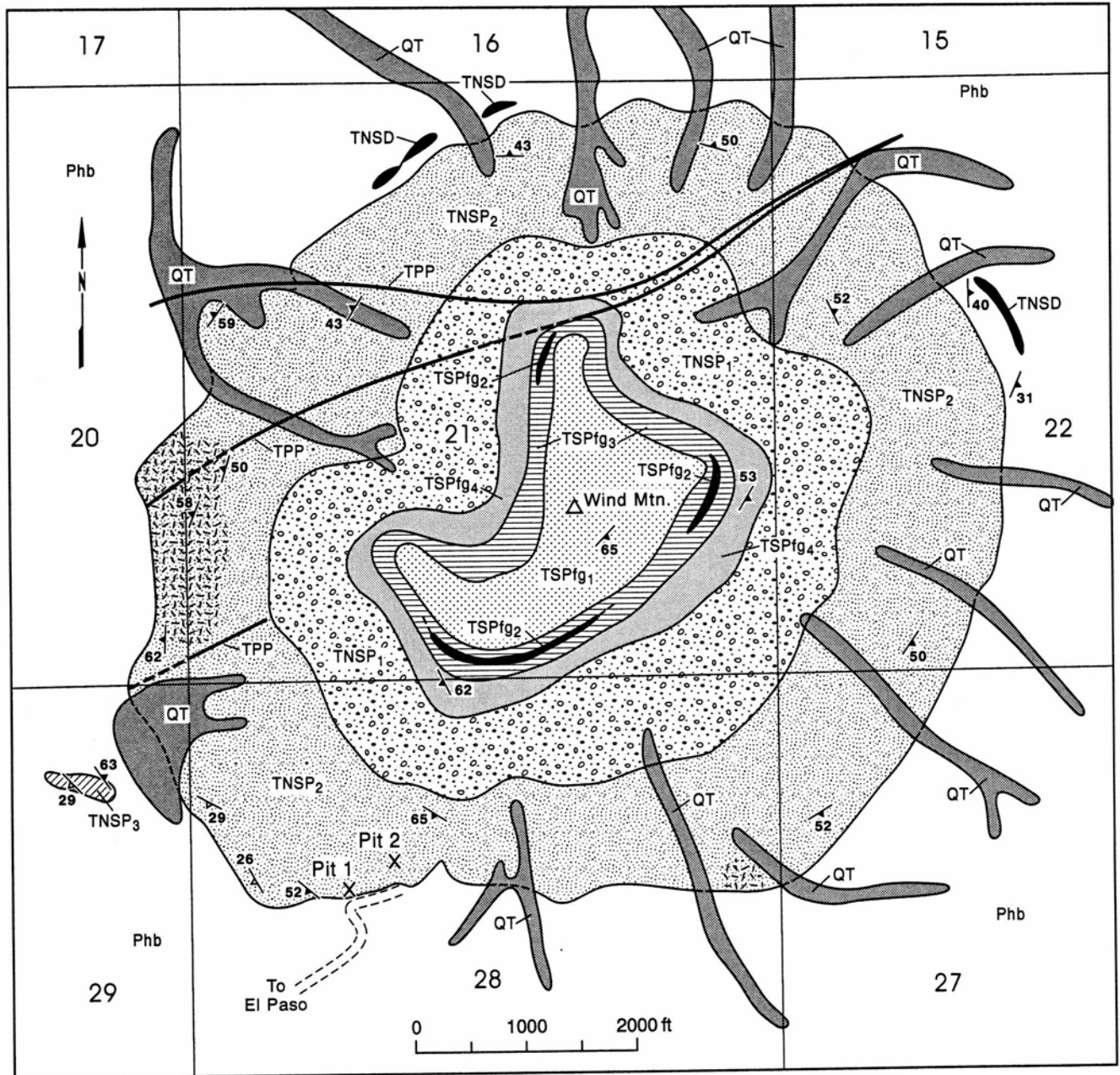

FIGURE 4—Geologic map of Wind Mountain (P. Gruseah, field mapping, July 1992).

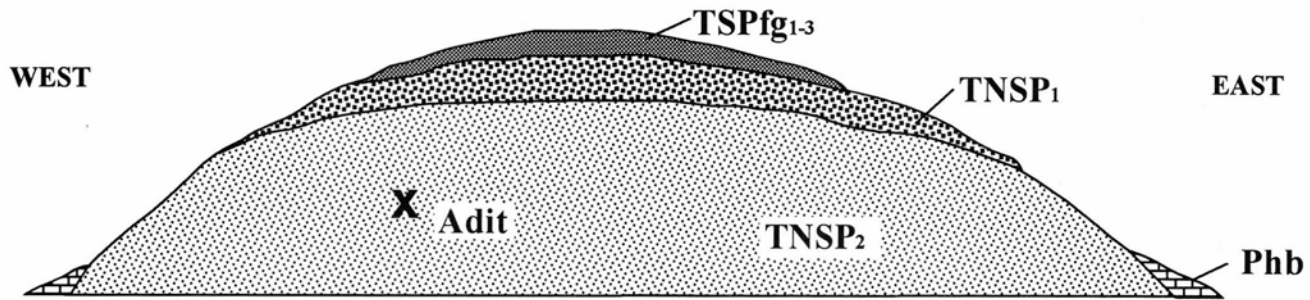

FIGURE 5—Schematic cross section of Wind Mountain pluton.

### Mineral Deposits

In the 1950s prospectors located several areas of anomalously high radioactivity in the Cornudas Mountains and attributed it to the presence of uranium. Shallow prospect pits were dug on many of the claims in the area; however, assay results were very low and the claims were later dropped with no production. In 1956 the U.S. Atomic Energy Commission examined the area to evaluate the potential for uranium (Collins, 1958). Subsequent assays ranged from 0 to 0.8%  $U_3O_8$  (Collins, 1958). No further work was recommended. The potential for economic uranium deposits in the **Cornudas Mountains appears low** because of low assays in areas of anomalously high ra

dioactivity and a depressed uranium market (McLemore and Chenoweth, 1989).

Beryllium was first reported from the Cornudas Mountains during the 1940s (Warner et al., 1959). A few samples assayed contained as much as 0.2%  $BeO$  (Warner et al., 1959). Beryllium occurs in feldspar, nepheline, aegirine, and eudialite within dikes, sills, and laccoliths in the Cornudas Mountains; no beryllium minerals have been identified. In the Chess Draw area northwest of Wind Mountain, only one sample contained 150 ppm Be whereas the remaining samples contained less than 100 ppm Be (U.S. Borax, written comm. 1986; Schreiner, 1994). The resource **potential** for beryllium is moderate to high. Exploration

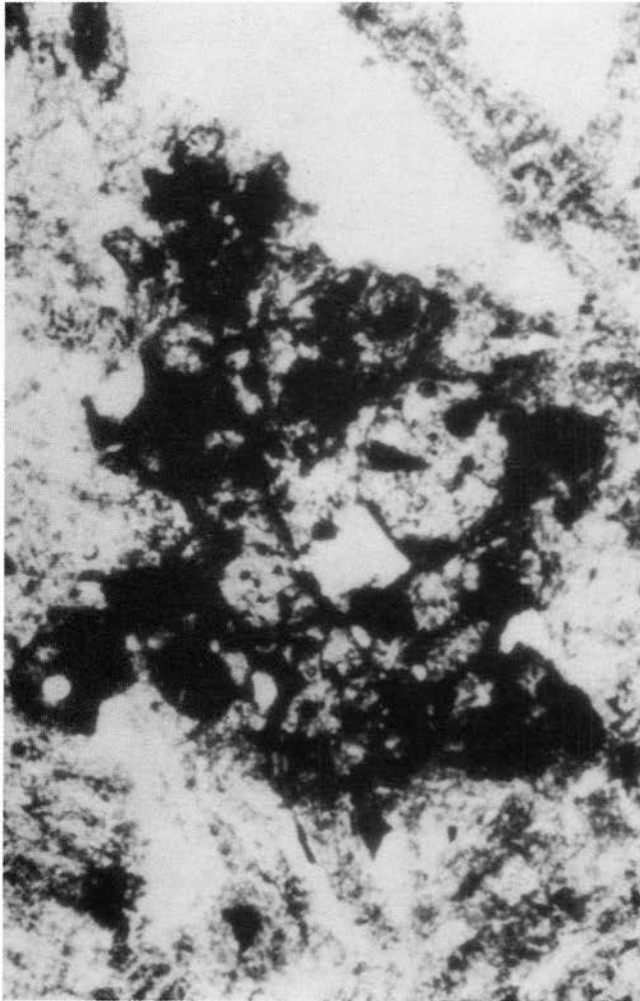

FIGURE 6—Photomicrograph of porphyritic nepheline syenite (TNSP<sub>2</sub>), sample CORN 31. Note the mafic minerals occur in aggregates within the trachytic feldspars and nepheline. Field of view is 2 mm in the long dimension.

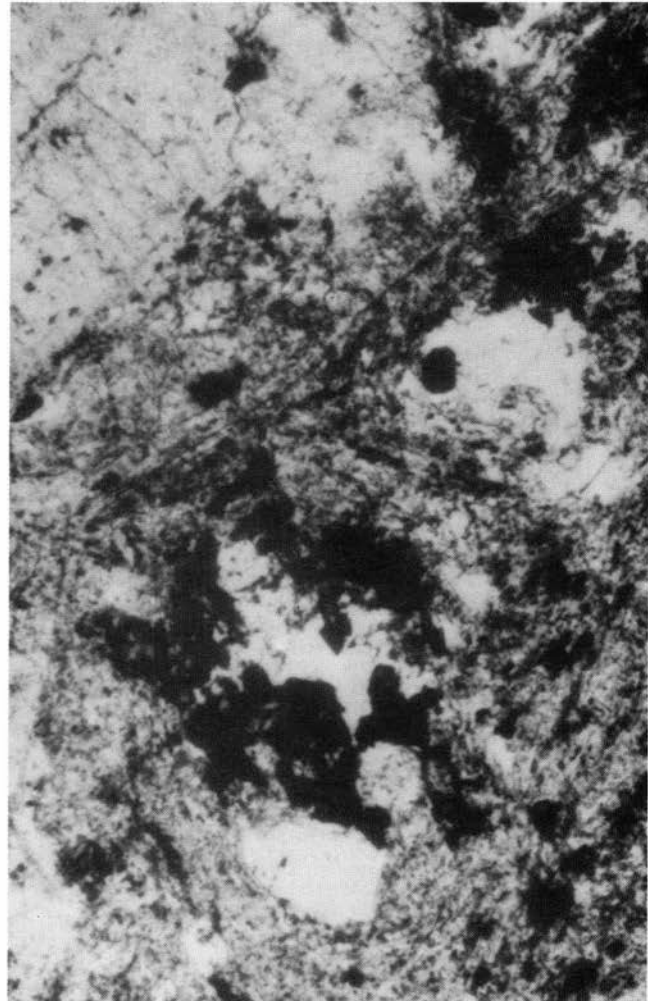

FIGURE 7—Photomicrograph of porphyritic syenite (TSPfg<sub>1</sub>). Subhedral analcime is associated with the mafic minerals. A large alkali-feldspar phenocryst is in the upper left corner of the photograph. Field of view is 2 mm in the long dimension.

TABLE 1—Mineralogical analyses of the Wind Mountain nepheline syenite.

Unit	Albite	K-feldspar	Alkali-feldspar	Nepheline	Amphibole	Pyroxene	Zeolite	Magnetite	Mica
TNSP <sub>1</sub>	—	—	70	10	3	5	8	2	2
TNSP <sub>2</sub>	—	—	77	12	2	4	2	2	1
TSPfg <sub>1</sub>	58	20	—	2	3	4	8	3	2
TSPfg <sub>2</sub>	57	20	—	2	2	8	8	1	2
TSPfg <sub>3</sub>	54	20	—	1	4	5	14	1	1
TSPfg <sub>4</sub>	63	19	—	2	3	6	3	3	1

TABLE 2—Chemical composition of unprocessed, raw nepheline syenite from Cornudas Mountains, New Mexico and Texas; and Blue Mountain, French River, and Rutter, Ontario, Canada.

	Average Wind Mountain (TNSP <sub>2</sub> ) <sup>1</sup>	Range of Wind Mountain (TNSP <sub>2</sub> ) samples <sup>1</sup>	Deer Mountain <sup>2</sup>	Blue Mountain, Ontario <sup>3</sup>	French River, Ontario <sup>3</sup>	Rutter, Ontario <sup>3</sup>
SiO <sub>2</sub>	59.84	56.3 – 63.3	56.3	59.18	56.35	59.03
TiO <sub>2</sub>	0.12	0.03 – 0.14	0.46	0.06	0.16	0.03
Al <sub>2</sub> O <sub>3</sub>	18.84	17.6 – 20.8	18.8	23.06	20.31	21.81
Fe <sub>2</sub> O <sub>3</sub> *	4.90	1.54 – 6.48	7.01	2.15	7.19	3.82
MgO	0.73	0.07 – 1.80	0.40	0.17	0.11	0.06
CaO	1.23	0.68 – 1.40	1.52	0.76	1.69	0.53
K <sub>2</sub> O	5.35	4.80 – 6.32	5.31	3.94	4.86	4.36
Na <sub>2</sub> O	7.82	7.20 – 8.80	7.61	10.48	8.31	10.78
MnO	0.27	0.14 – 0.35	0.23	—	0.18	0.03
P <sub>2</sub> O <sub>5</sub>	0.11	<0.05 – 0.11	0.17	0.02	0.04	0.02
LOI	2.24	1.02 – 2.91	2.82	0.40	1.36	0.15
TOTAL	101.45	—	100.63	100.22	100.56	100.62

<sup>1</sup>From McLemore and Guilinger (1993, in press) and McLemore et al. (1996). Unaltered surface and drill-core samples (n=5).

<sup>2</sup>From Barker et al., 1977, (n=4).

<sup>3</sup>From Guillet (1994).

\* Total iron as Fe<sub>2</sub>O<sub>3</sub>.

TABLE 3—Selected minerals and their occurrence reported from the Cornudas Mountains.

Mineral	Occurrence	Reference
Anaclime	Replaces nepheline, lines vugs, vesicles and miarolitic cavities	Barker & Hodges (1977); Boggs (1985)
Natrolite	Replaces nepheline and feldspars	Barker & Hodges (1977)
Olivine	Mineral aggregates of ferromagnesian minerals and magnetite	Barker & Hodges (1977)
Aenigmatite	In nepheline syenite	Barker & Hodges (1977)
Eudialyte <sup>1</sup>	In dikes, sills, and laccoliths and in marolitic cavities	Barker & Hodges (1977); Clabaugh (1950); Boggs (1985, 1987)
Catapleiite <sup>2</sup>	Miarolitic cavities	Boggs (1985)
Georgechaoite <sup>3</sup>	Miarolitic cavities	Boggs (1985); Boggs & Ghose (1985)
Aegirine (acmite)	Miarolitic cavities	Boggs (1985, 1987)
Monazite	Miarolitic cavities	Boggs (1985)
Thomsonite	Miarolitic cavities	Zapp (1941); Boggs (1985)
Chabazite	Miarolitic cavities	Boggs (1985)
Parakeldyshite <sup>4</sup>	Nepheline syenite, Wind Mountain	This report
Pyrite	Mineral aggregates of ferromagnesian minerals	This report
Fluorite	Breccia	Barker et al. (1977)

Chemical formulae of rare species: <sup>1</sup>Na<sub>4</sub>(Ca,Ce)<sub>2</sub>(Fe<sup>2+</sup>,Mn<sup>2+</sup>)YZrSi<sub>8</sub>O<sub>22</sub>(OH,Cl)<sub>2</sub>; <sup>2</sup>Na<sub>2</sub>ZrSi<sub>3</sub>O<sub>9</sub>·2H<sub>2</sub>O; <sup>3</sup>NaKZrSi<sub>3</sub>O<sub>9</sub>·2H<sub>2</sub>O; <sup>4</sup>Na<sub>2</sub>ZrSi<sub>2</sub>O<sub>7</sub>

should concentrate along the intrusive contacts between the Tertiary intrusives and Permian limestones for the potential discovery of a replacement beryllium deposit similar to that found at Sierra Blanca, Texas.

A variety of deposits containing gold and silver are associated with alkaline igneous rocks in New Mexico (Great Plains Margin deposit; North and McLemore, 1986, 1988; McLemore, 1991, in press) and elsewhere along the North American Cordilleran alkaline igneous belt (Mutschler et al., 1991; Thompson, 1991, 1992). These deposits have yielded nearly 13% of the total lode gold produced in the United States and Canada (Mutschler et al., 1991). Consequently, numerous private companies have examined

the Cornudas Mountains for similar gold—silver deposits, but without success (McLemore and Guilinger, 1993).

Alkaline igneous rocks are known to contain high concentrations of rare-earth elements, niobium, zirconium, and titanium. Economic deposits are rare but do occur associated with alkaline igneous complexes (Woolley, 1987). A few companies have examined the Cornudas Mountains unsuccessfully for similar deposits. U.S. Borax sampled and drilled in the Chess Draw area, but their assays were low (up to 0.06% total rare-earth oxides, 10-1,400 ppm Nb, 10-3,000 ppm Zr, 230-13,000 ppm F). An analysis reported by McLemore et al. (1988a, b) contained 1,235 ppm Ce, 700 ppm La, 270 ppm Nd, and 242

TABLE 4—Uses of nepheline syenite (after Allen and Charsley, 1968; Guillet, 1994; McLemore et al., 1994; McLemore and Guilinger, this volume).

Use	Specifications and characteristics	Location and company
Glass (including fiberglass, containers, flat glass)	40–200 mesh; <0.1% Fe <sub>2</sub> O <sub>3</sub> , >23% Al <sub>2</sub> O <sub>3</sub> , >14% alkalis for clear glass	Unimin Canada Ltd. at Blue Mountain, Ontario, and North Cape, Norway
Ceramics (tiles, sanitary ware, china, brickware, earthenware)	200, 270, 400 mesh, free of dark minerals, must fuse on firing to uniform white body for certain specifications	Unimin Canada Ltd. at Blue Mountain, Ontario and North Cape, Norway Bursa Orhaneli, Turkey (floor tiles in 1989)
Extender, pigments and fillers (plastics, paints, sealers, stains foam carpet backing)	Finely ground, high dry brightness (96–98), average refractive index 1.53, oil absorptions 22–29%	Unimin Canada Ltd. at Blue Mountain, Ontario
Alumina, alkali carbonates, cements (including refractory cements)	High concentrations of alumina and alkali	Kola Peninsula, Russia
Roofing granules	High UV attenuation, resistance to weathering	3M Company at Fourche Mountain, Arkansas
Sand blasting, abrasives	Silica-free	Badger Mining
Dimension stone, ornamental, and aggregate	—	Minor uses at various localities
Fertilizer	Slow rate of decomposition, high alkali content	Experimental studies in 1929–1932 in the U.S.S.R. and Brazil

ppm Y. Analyses reported by Schreiner (1994) are also low (up to 3,790 ppm total REE, 2,332 ppm Nb, and 3,137 ppm F). Zirconium silicates are common in the area. The resource potential for economic deposits of rare-earth elements, niobium, zirconium, and titanium is unknown in the Cornudas Mountains. Additional geologic, geochemical, geophysical, and other exploration techniques are required to properly evaluate this area, especially in dikes and along intrusive contacts with the limestones.

### Nepheline-syenite deposits

Nepheline syenite is a constituent in manufacturing glass, ceramics, and flatware (Table 4; Allen and Charsley, 1968; Guillet, 1994; Bourne, 1994; O'Driscoll, 1990; Potter, 1990). More than 20 industrial minerals and rocks are utilized in the manufacture of various forms of glass (O'Driscoll, 1990). Nepheline syenite is an inexpensive source of essential alumina, soda, and ash. Nepheline syenite also improves the workability of the glass batch by lowering the viscosity, and it imparts a unique quality of toughness to the glass which makes it more resistant to breakage.

Nepheline syenite is also used as extender pigments, fillers, roofing granules, dimension stone, abrasive, and aggregate (Table 4; Allen and Charsley, 1968; Guillet, 1994; McLemore and Guilinger, 1993, this volume; McLemore et al., 1994). It is desired in pigments and fillers because it has a high brightness, inertness, and easy wetting and dispersion in parent formulations. The UV attenuation characteristics and resistance to weathering of nepheline syenite provide for use as roofing granules by blocking sunlight and retarding degradation in asphalt roofs. The lack of quartz or free silica and relative hardness also enable use of nepheline syenite as a silica-free abrasive. Nepheline syenites have also been examined for potential sources of alumina and alkalis (Allen and Charsley, 1968). Other potential uses include as fertilizers, ingredients in refractory cement, and paper (Allen and Charsley, 1968).

The outer zone of the Wind Mountain nepheline syenite (INSP2) is currently being developed for use as a con-

stituent in glass, ceramics, and flatware and for use as an abrasive. The nepheline syenite is high in iron (Table 2) compared to other commercial sources of nepheline syenite. However, when the Wind Mountain nepheline syenite is crushed and passed through a specialized rare-earth magnet, the resulting product is similar in composition to Grade B product specified by Unimin Canada Ltd. (Table 5), and has been certified by Coors Inc. as being suitable for amber-colored glass and ceramics. The lack of quartz, and a Mohs hardness higher than 6 enable use of the Wind Mountain nepheline syenite as a silica-free abrasive (McLemore et al., 1994; McLemore and Guilinger, this volume). Physical and chemical test results of Wind Mountain nepheline syenite meet or exceed standards for use as roofing granules, dimension stone, aggregate, and abrasives (McLemore et al., 1994; McLemore and Guilinger, this volume).

Mining will be by room-and-pillar methods. Processing will involve crushing, grinding, magnetic separation, and screening. The magnetic fraction can be sold as millite, an iron-rich additive required for controlling the color of glass. At full production, Wind Mountain is expected to process 3,000 short tons (st) per day or 700,000 st per year. Current proven, probable, and inferred reserves total 200 million st for a mine life of more than 100 years.

Additional mineral-resource potential in the Cornudas Mountains is limited. The nepheline syenite of Deer and San Antonio Mountains (Fig. 3) may have potential use for glass or ceramics. The other laccoliths, dikes, plugs, and sills are not suitable for glass or ceramic use because of high iron contents and heterogeneous composition. The lack of large-scale hydrothermal alteration associated with the emplacement of laccoliths in the region suggests that potentially economic mineralization is limited. However, the abundant rare mineralogies at Wind Mountain suggest a potential for undiscovered deposits of rare-earth elements, niobium, and zirconium.

### Summary

The alkaline rocks in the Cornudas Mountains are part of complex magmatic differentiation possibly related to



TABLE 5—Chemical analyses of nepheline syenite after magnetic separation from Wind Mountain, New Mexico, compared to raw composition of Blue Mountain nepheline syenite and typical glass-grade compositions. LOI= Loss on ignition.

	Wind Mountain TNSP <sub>2</sub> Pit 1	Wind Mountain TNSP <sub>2</sub> Pit 2	Unimin Canada	Elkenm Neflin, Unimin Canada Ltd., A Grade	North Cape, Ltd., B Grade Norway
SiO <sub>2</sub>	64.70	63.80	60.2	60.1	55.9
Al <sub>2</sub> O <sub>3</sub>	20.50	20.90	23.5	23.4	24.2
Fe <sub>2</sub> O <sub>3</sub>	0.52	0.40	0.08	0.35	0.1
Na <sub>2</sub> O	7.62	8.23	10.6	10.5	7.9
K <sub>2</sub> O	6.74	6.73	5.1	4.9	9.0
CaO	0.23	0.20	0.3	0.3	1.3
MgO	<0.05	<0.05	trace	trace	trace
TiO <sub>2</sub>	<0.01	<0.01	—	—	—
ZrO <sub>2</sub>	<0.01	<0.01	—	—	—
P <sub>2</sub> O <sub>5</sub>	<0.05	<0.05	—	—	0.1
LOI	—	—	0.4	0.3	1.0
TOTAL	100.31	100.26	100.18	99.85	99.5
Reference	McLemore et al. (1994)	McLemore et al. (1994)	Guillet et al. (1994)	Guillet et al. (1994)	Guillet et al. (1994)
	McLemore and Guilinger (in press)	McLemore and Guilinger (in press)			

\*Total iron as Fe<sub>2</sub>O<sub>3</sub>

the progressive shallowing of the subduction of the Farallon plate beneath the North American plate with time. Wind Mountain consists of two textural varieties of nepheline-syenite porphyry and four textural varieties of syenite porphyry. The zonation in the Wind Mountain laccolith appears to be controlled by crystal fractionation, volatile separation, and cooling history rather than by different pulses of magma (McLemore et al., 1996). Feldspar crystallization under initially subsolvus conditions can account for most of the variations in the zones. The area has limited potential for gold, silver, beryllium, rare-earth elements, niobium, and uranium, but no economic deposits have been found. The Wind Mountain nepheline syenite has excellent potential for use in amber-colored beverage containers, ceramics, roofing granules, abrasives, aggregate, and dimension stone. It compares chemically to Unimin's class B nepheline-syenite product. Other areas in the Cornudas Mountains and elsewhere in New Mexico have been examined for use as feldspar and nepheline syenite, but none of these areas are as favorable as the Wind Mountain nepheline syenite.

#### Acknowledgments

Special thanks are to P. Gruaseah for his geologic map of Wind Mountain. Discussions with Mark Ouimette and Robert Guilinger benefitted our understanding of the regional geology. Robert Guilinger reviewed an earlier version of this manuscript. Sample preparation by Daniel Hack and David Bright is acknowledged. Figures were drafted by the NMBMMR Cartography Department and the manuscript was typed by Terry Telles. This work is supported by NMBMMR (Charles E. Chapin, Director and State Geologist) and Addwest Minerals Inc. (James R. Guilinger, project supervisor).

#### References

Allen, J. B., and Charsley, T. J., 1968, Nepheline-syenite and phonolite: Institute of Geological Sciences, London, UK, 169 pp.  
 Barker, D. S., 1977, Northern Trans-Pecos magmatic province: Introduction and comparison with the Kenya rift: Geological Society of America Bulletin, v. 88, pp. 1421-1427.  
 Barker, D. S., 1979, Cenozoic magmatism in the Trans-Pecos prov-

ince: Relation to Rio Grande rift; *in* Riecker, R. E. (ed.), Rio Grande rift: Tectonics and magmatism: American Geophysical Union, pp. 382-392.

- Barker, D. S., 1987, Tertiary alkaline magmatism in Trans-Pecos Texas; *in* Fitton, J. G., and Upton, B. G. J. (eds.), Alkaline igneous rocks: The Geological Society, Special Publication 30, pp. 415-431.  
 Barker, D. S., and Hodges, F. N., 1977, Mineralogy of intrusions in the Diablo Plateau, northern Trans-Pecos magmatic province, Texas and New Mexico: Geological Society of America Bulletin, v. 88, pp. 1428-1436.  
 Barker, D. S., Long, L. E., Hoops, C. K., and Hodges, F. N., 1977, Petrology and Rb-Sr isotope geochemistry of intrusions in the Diablo Plateau, northern Trans-Pecos magmatic province, Texas and New Mexico: Geological Society of America Bulletin, v. 88, pp. 1437-1446.  
 Boggs, R. C., 1985, Mineralogy of the Wind Mountain laccolith, Otero County, New Mexico (abs.): New Mexico Geology, v. 7, pp. 41-42.  
 Boggs, R. C., 1987, Mineralogy and textures of an eudialyte-bearing dike, Wind Mountain, Otero County, New Mexico (abs.): New Mexico Geology, v. 9, p. 22.  
 Boggs, R. C. and Ghose, S., 1985, Georgechaoite, NaKZrSi<sub>3</sub>O<sub>9</sub>·2H<sub>2</sub>O, a new species from Wind Mountain, New Mexico: Canadian Mineralogist, v. 23, pp. 1-4.  
 Bourne, H. L., 1994, Glass raw materials; *in* Carr, D. D. (ed.), Industrial minerals and rocks, 6th ed.: Society for Mining, Metallurgy, and Exploration Inc., Littleton, Colorado, pp. 543-550.  
 Cameron, K. L., and Cameron, M., 1985, Rare-earth elements, <sup>87</sup>Sr/<sup>86</sup>Sr and <sup>143</sup>Nd/<sup>144</sup>Nd compositions of Cenozoic orogenic dacites from Baja California, northwestern Mexico and adjacent west Texas: Evidence for the predominance of a sub-crustal component: Contributions to Mineralogy and Petrology, v. 91, pp. 1-11.  
 Campa, M. F., and Coney, P. J., 1983, Tectono-stratigraphic terranes and mineral resource distributions in Mexico: Canadian Journal of Earth Sciences, v. 20, pp. 1040-1051.  
 Clabaugh, S. E., 1941, Geology of the northwestern portion of the Comudas Mountains, New Mexico: Unpublished MS thesis, University of Texas (Austin), 66 pp.  
 Clabaugh, S. E., 1950, Eudialyte and euclolite from southern New Mexico (abs.): American Mineralogist, v. 35, pp. 279-280.  
 Clark, K. F., 1989, Metallogenic provinces and epochs in Mexico: 28th International Geological Congress, Abstracts, v. 1, p. 300.  
 Collins, G. E., 1958, Preliminary reconnaissance for uranium in

- the Comudas Mountains, Otero County, New Mexico and Hudspeth County, Texas: U.S. Atomic Energy Commission, Report DBO-4TM-5, 16 pp.
- Coney, P. J., 1972, Cordilleran tectonics and North American plate motions: *American Journal of Science*, v. 272, pp. 603-628.
- Damon, P. E., Shafiqullah, M., and Clark, K. F., 1981, Age trends of igneous activity in relation to metallogenesis in the southern Cordillera: *Arizona Geological Society Digest*, v. 14, pp. 137-154.
- Guinett, G. R., 1994, Nepheline syenite; *in* Carr, D. D. (ed.), *Industrial minerals and rocks*, 6th ed.: Society for Mining, Metallurgy, and Exploration Inc., Littleton, Colorado, pp. 74-730.
- Henry, C. D., Price, J. G., and James, E. W., 1991, Mid-Cenozoic stress evolution and magmatism in the southern Cordillera, Texas and Mexico: Transition from continental arc to intraplate extension: *Journal of Geophysical Research*, v. 96, no. B8, pp. 13,545-13,560.
- Henry, C. D., McDowell, F. W., Price, J. G., and Smyth, R. C., 1986, Compilation of potassium-argon ages of Tertiary igneous rocks, Trans-Pecos Texas: University of Texas (Austin), Bureau of Economic Geology, Geological Circular 86-2, pp. 6-7.
- Henry, C. D., Price, J. G., Parker, D. F., and Wolf, J. A., 1989, Excursion 9A: Mid-Tertiary silicic alkalic magmatism of Trans-Pecos Texas-Rheomorphic tuffs and extensive silicic lavas; *in* Chapin, C. E., and Zidek, J. (eds.), *Field excursions to volcanic terranes in the western United States*, Volume 1: Southern Rocky Mountains region: New Mexico Bureau of Mines and Mineral Resources, Memoir 46, pp. 231-274.
- King, W. E., and Harder, V. M., 1985, Oil and gas potential of the Tularosa Basin-Otero platform-Salt Basin graben area, New Mexico and Texas: New Mexico Bureau of Mines and Mineral Resources, Circular 198, 36 pp.
- McLemore, V. T., 1991, Base- and precious-metals in Lincoln and Otero Counties, New Mexico; *in* Barker, J. M., Kues, B. S., Austin, G. S., and Lucas, S. G. (eds.), *Geology of the Sierra Blanca, Sacramento, and Capitan Ranges, New Mexico*: New Mexico Geological Society, Guidebook 42, pp. 305-310.
- McLemore, V. T., in press, Great Plains margin (alkalic related) gold deposits in New Mexico; *in* *Geology and ore deposits of the American Cordillera*: Geological Society of Nevada, Symposium proceedings.
- McLemore, V. T., and Chenoweth, W. L., 1989, Uranium resources in New Mexico: Distribution, geology, production, and resources: New Mexico Bureau of Mines and Mineral Resources, Resource Map 18, 36 pp.
- McLemore, V. T., and Guiling, J. R., 1993, Geology of mineral resources of the Cornudas Mountains, Otero County, New Mexico and Hudspeth County, Texas; *in*, Love, D. W., Hawley, J. W., Kues, B. S., Adams, J. W., Austin, G.S., and Barker, J. M. (eds.), *Carlsbad Region, New Mexico and Texas*: New Mexico Geological Society, Guidebook 44, pp. 145-153.
- McLemore, V. T., and Guiling, J. R., this volume, Industrial specifications of the Wind Mountain nepheline syenite deposit, Cornudas Mountains, Otero County, New Mexico: New Mexico Bureau of Mines and Mineral Resources, Bulletin 154.
- McLemore, V. T., Guiling, J. R., and Oumiette, M. A., 1994, Geology of the Wind Mountain nepheline syenite deposit, Cornudas Mountains, Otero County, New Mexico: Society for Mining, Metallurgy, and Exploration Inc. Preprint 94-63, 10 pp.
- McLemore, V. T., Lueth, V. W., Pease, T. C., and Guiling, J. R., 1996, Petrology and Mineral resources of the Wind Mountain laccolith, Cornudas Mountains, New Mexico and Texas: *Canadian Mineralogist*, v. 34, in press.
- McLemore, V. T., North, R. M., and Leppert, S., 1988a, REE, niobium, and thorium districts and occurrences in New Mexico: New Mexico Bureau of Mines and Mineral Resources, Open-file Report OF-324, 27 pp.
- McLemore, V. T., North, R. M., and Leppert, S., 1988b, Rare-earth elements (REE) in New Mexico: *New Mexico Geology*, v. 10, pp. 33-38.
- Mutschler, F. E., Griffin, M. E., Stevens, D. S. and Shannon, S. S., Jr., 1985, Precious metal deposits related to alkaline rocks in the North American Cordillera-An interpretive review: *Geological Society of South America Transactions*, v. 88, pp. 355377.
- Mutschler, F. E., Mooney, T. C., and Johnson, D. C., 1991, Precious metal deposits related to alkaline igneous rocks-A space-time trip through the Cordillera: *Mining Engineering*, v. 43, pp. 304-309.
- North, R. M., and McLemore, V. T., 1986, Silver and gold occurrences in New Mexico: New Mexico Bureau of Mines and Mineral Resources, Resource Map 15, 35 pp, scale 1:1,000,000.
- North, R. M., and McLemore, V. T., 1988, A classification of the precious metal deposits of New Mexico; *in* Schafer, R. W., Cooper, J. J., and Vitre, P. G. (eds.), *Bulk minable precious metal deposits of the western United States*: Geological Society of Nevada, Symposium Proceedings, pp. 625-659.
- O'Driscoll, M., 1990, U.S. glass industry-Overcapacity shadows strong demand: *Industrial Minerals*, no. 269, pp. 34-53.
- Pearce, J. A., Harris, N. B. W., and Tindle, A. G., 1984, Trace element discrimination diagrams for the tectonic interpretation of granitic rocks: *Journal of Petrology*, v.25, pp. 956-983.
- Potter, M. J., 1990, Annual report of feldspar, nepheline syenite and aplite: U.S. Bureau of Mines, 6 pp.
- Potter, L. S., 1994, Influence of the North American craton margin on chemical and isotopic variation along strike in the eastern alkalic belt, Trans-Pecos magmatic province, Texas and New Mexico (abs.): Geological Association of Canada, Annual Meeting, Program with Abstracts, p. A89.
- Price, J. G., and Henry, C. D., 1984, Stress orientations during Oligocene volcanism in Trans-Pecos Texas: Timing the transition from Laramide compression to Basin and Range tension: *Geology*, v. 12, pp. 238-241.
- Price, J. G., Henry, C. D., Barker, D. S., and Parker, D. F., 1987, Alkalic rocks of contrasting tectonic settings in Trans-Pecos Texas; *in* *Mantle metasomatism and alkaline magmatism*: Geological Society of America, Special Paper 215, pp. 335-346.
- Schreiner, R. A., 1994, Mineral investigation of Wind Mountain and the Chess Draw area, Cornudas Mountains, Otero County, New Mexico: U.S. Bureau of Mines, MIA 26-94, 46 pp.
- Sillitoe, R. H., 1972, Relation of metal provinces in western American to subduction of oceanic lithosphere (abs): Geological Society of America, Abstracts with Programs, South-Central Section, p. 14.
- Timm, B. C., 1941, The geology of the southern Cornudas Mountains, Texas and New Mexico: Unpublished MS thesis, University of Texas (Austin), 55 pp.
- Thompson, T. B., 1991, Genesis of gold associated with alkaline igneous rocks (abs.): Geological Society of America, Abstracts with Programs, v. 23, pp. 99-100.
- Thompson, T. B., 1992, Mineral deposits of the Cripple Creek district, Colorado: *Mining Engineering*, v. 44, pp. 135-143.
- Warner, L. A., Holser, W. T., Wilmarth, V. R., and Cameron, E. N., 1959, Occurrence of nonpegmatite beryllium in the United States: U.S. Geological Survey, Professional Paper 318, 198 pp.
- Woolley, A. R., 1987, Alkaline rocks and carbonatites of the world, Part 1: North and South America: University of Texas Press, Austin, and British Museum of Natural History, Cambridge, UK, 216 pp.
- Zapp, A. D., 1941, Geology of the northeastern Cornudas Mountains, New Mexico: Unpublished MS thesis, University of Texas (Austin), 63 pp.



# Garnet resource potential in southern New Mexico

Virgil W. Lueth

New Mexico Bureau of Mines & Mineral Resources, New Mexico Tech, 801 Leroy Place, Socorro, New Mexico 87801-4796, U.S.A

**Abstract**—Large garnet deposits in southern New Mexico contain significant reserves of industrial-grade andradite to grossular garnets. These deposits are found in a variety of skarn types accompanied by significant metal mineralization. Most of these skarn deposits are confined to upper Paleozoic limestone host rocks. Most deposits are exposed in younger fault blocks of the Rio Grande rift or Basin-and-Range province.

The compositions, textures, and fracture characteristics of the garnets in these deposits are dependent on the type of skarn. Five types of skarn deposits are present in the study area: (1) copper, (2) porphyry copper, (3) lead-zinc, (4) iron, and (5) tungsten. The largest garnet deposits are hosted in copper skarn, usually associated with porphyry copper deposits of Cretaceous age in southwestern New Mexico (e.g. Chino and Cobre mines). Host rocks include the Lake Valley (Mississippian), Oswaldo, and Syrena Formations (both Pennsylvanian). The volumetrically largest garnet replacements are confined to the Oswaldo Formation, but the purest garnet replacements are found in the Lake Valley Formation. Garnet deposits are strongly altered near post-mineralization faults, probably due to retrograde alteration. Garnet is commonly altered to clay and epidote in proximity to sulfide mineralization. Compositions are variable throughout the deposits, ranging from pure andradite at the igneous contact to pure grossular in metamorphic-stage pods. Average garnet compositions are usually higher than  $Ad_{80}$ . Garnet replacement favors the purer limestone protoliths. Grain sizes range from 1 mm to 10 cm in diameter, averaging 4 mm.

The second largest type of garnet deposit is associated with lead-zinc skarns, mainly in the Hanover-Fierro mining district, southwestern New Mexico. The host rocks are the same as in the copper deposits mentioned above. Garnet in these deposits is less altered and often removed from sulfide mineralization. Garnet compositions tend toward andradite ( $Ad_{60-100}$ ) with a significant spessartine component ( $Sp_{1-24}$ ). Garnets tend to be less fractured in lead-zinc skarns than in copper skarn types and often exhibit reverse zonation. Grain sizes are on average smaller than for copper skarn types. Garnet grains in lead-zinc skarns have fewer mineral-grain inclusions than garnets in copper skarns.

Iron skarn represents the smallest skarn subclass in southern New Mexico, but it contains the best quality garnet. Iron skarns are found in the Hanover-Fierro district and the Orogrande district (south-central New Mexico). Garnet compositions vary widely ( $Ad_{10-85}$ ). Garnet grain sizes are similar to copper skarn types but also display less fracturing and growth zoning. Garnet replacements occur along bedding and are often separate from oxides and sulfides. Mineral inclusions are often seen in the core zones of these garnets.

Past metal mining in all skarn districts often left the barren garnetite (the best garnet ore) in place. Many of the deposits are at the surface and can be mined successfully by open-pit methods. Underground mining of garnets, to minimize surface disruption, is also possible from deposits that already have a significant amount of underground workings.

## El potencial de yacimientos de granate en el sur de Nuevo Mexico

**Resumen**—**Extensos** yacimientos en el sur de Nuevo México contienen reservas apreciables de granates (desde andradita hasta grosularia) de calidad industrial. Estos depósitos se encuentran en una variedad de tipos de *skarn* asociados con importante mineralización metalífera. La mayoría de estos depósitos de *skarn* se alojan en calizas del Paleozoico superior. La mayoría de los yacimientos afloran en bloques de falla más recientes, sea en el *rift* del Rio Grande o en la provincia tectónica de Bolsones y Sierras (*Basin and Range*).

La composición, textura y características de fractura de estos granates dependen del tipo de *skarn*. Cinco tipos de *skarn* se distinguen en el distrito, a saber: (1) cobre, (2) cobre porfirico, (3) plomo-zinc, (4) hierro y (5) tungsteno. Los yacimientos más grandes se alojan en el *skarn* de cobre y generalmente se asocian con depósitos de pórfiro cuprífero del Cretácico en el suroeste de Nuevo México (por ejemplo las minas Chino y Cobre). La roca madre puede ser la Formación *Lake Valley* (Missisipiano), o las formaciones *Oswaldo* y *Syrena* (ambas del Pennsylvaniano). Los yacimientos de mayor volumen están en la Formación *Oswaldo*, pero los granates metasomáticos más puros se encuentran en la Formación *Lake Valley*. Cerca de fallas posteriores a la mineralización los depósitos de granate se hallan fuertemente alterados; esto se debe probablemente a un proceso de alteración retrógrada. En la proximidad de mineralización de sulfuros es común encontrar el granate alterado a arcilla o epidoto. En un mismo yacimiento, la composición varía entre andradita pura en el contacto ígneo y grosularia pura en lentes alargadas.

de la zona metamórfica. La composición media generalmente supera el  $Ad_m$ . La sustitución metasomática por granates prefiere los protolitos de caliza más pura. Los tamaños de grano varían del milímetro a 10 cm, con un promedio de 4 mm.

Los yacimientos que siguen en tamaños son los que se asocian con los *skarns* de plomo-zinc y se encuentran principalmente en el distrito de Hanover—Fierro (suroeste de Nuevo México). Las rocas de caja son las ya mencionadas. El granate en estos yacimientos está menos alterado y muchas veces remoto de la mineralización sulfurica. La composición tiende a andradita ( $Ad_{60-100}$ ), con un componente apreciable de espesartina ( $Spl_{1-24}$ ). Los granates tienden a estar menos fracturados que en el *skarn* de cobre y frecuentemente exhiben zonación inversa (*inverse zoning*). Los granos de granate en *skarn* de plomo-zinc tienen menor cantidad de inclusiones de granos minerales que los granates en *skarn* de cobre.

*Skarn* de hierro es la clase de *skarn* de menor difusión y volumen en el sur de Nuevo México pero contiene los granates de mejor calidad. Se los encuentra en los distritos de Hanover—Fierro y de Orogrande (en el centro-sur de Nuevo México). La composición es muy variable ( $Ad_{10-85}$ ). Los tamaños de grano son similares a los del *skarn* de cobre pero son menos fracturados y exhiben menor zonamiento. El metasomatismo se produjo a lo largo de pianos de sedimentación y muchas veces está separado de óxidos y sulfuros. Son frecuentes las inclusiones minerales en las zonas centrales de estos granates.

En todos los distritos de *skarn* la extracción de mena metalífera en el pasado dejó sin tocar la garnetita estéril (el mejor mineral de granate). Muchos de estos depósitos están en la superficie y pueden ser trabajados a cielo abierto. Para mitigar el trastornamiento de la superficie, también es posible la extracción subterránea en depósitos que ya han tenido desarrollo apreciable de extracción subterránea.

### Introduction

Garnet production in New Mexico has had an inauspicious past, consisting mainly of mineralogical specimens and gemstone trinkets sold to tourists. Up until the test production runs at the Royalstar Industries garnet mine at San Pedro (Fattah, 1994), official garnet production in the state consisted of 10 lbs of pyrope—almandine product sold to the Elgin watch company in the early 1930s (Gillerman, 1964). Numerous pyrope garnets (known as "Arizona rubies") have been sold from the Navajo reservation lands in northwestern New Mexico. These garnets have been concentrated by fluvial and eolian processes or biologic agents (ants and scorpions) and are gathered by hand.

Garnet has a long industrial history, having been used primarily as an abrasive (paper and loose grains). Modern garnet usage is undergoing a renaissance with expanded applications in abrasive jet cutting (Austin, 1994a) and as filtration media (Ives, 1993). The use of garnet in sand blasting is also increasing as a response to the health concerns over quartz, especially the incidence of silicosis. Austin (1994b) stated that garnet production is currently near capacity in the United States. As demand increases for nonsilica abrasives, the superiority of garnet product (greater hardness and angularity) over other abrasives (e.g. slags, feldspars, etc.) suggests that more garnet reserves will need to be developed. Royalstar Industries has already anticipated an increasing garnet market and initiated exploratory development of garnet at the San Pedro mine in the New Placers district of Santa Fe County, New Mexico (Fattah, 1994). Many deposits in southern New Mexico represent an even larger potential source of garnet.

Approximately one-third of all mining districts in southern New Mexico report garnet as a gangue mineral occurring with the metal-ore deposits, in pegmatites, or in placers (Fig. 1, Table 1). In many of the these districts, massive garnet replacement deposits (termed "skarns") acted as the host rock for most of the ore. Much of the mining history of southern New Mexico centers around silver, lead—zinc, iron, and copper skarn deposits. The presence of similar host rocks, intrusive rocks, and favorable structures lead to the formation of skarn deposits throughout southern New Mexico.

Five types of skarn deposits can be recognized in southern New Mexico: (1) copper, (2) porphyry copper, (3) lead—zinc, (4) iron, and (5) tungsten. Each type presents unique characteristics that must be understood in order to develop the deposit commercially. The purpose of this paper is to define the exploration strategies for large garnet deposits and to evaluate the nature of the garnet product within these different types of deposits. Pegmatite deposits of garnet have a very low potential for economic exploitation because of their small size, and therefore are not discussed. Placer deposits of garnet have not been evaluated, so the resource potential is unknown.

### Regional geology

Skarn deposits in southern New Mexico lie within the Basin-and-Range extensional tectonic province of North America. The area is bordered on the north by the relatively unextended Colorado Plateau and on the east by the Great Plains. The Basin-and-Range structural style continues southward into Mexico. The Rio Grande rift, a north-trending arm of the Basin-and-Range province, bisects New Mexico. These later extensional events are superimposed on compressional structures associated with the Laramide orogeny and the younger magmatic arc of the Sierra Madre Occidental and Mogollon—Datil volcanic provinces. Garnet deposits formed, during magmatism associated with the Laramide orogeny and younger magmatic events, adjacent to granitic intrusive rocks that range in age from Late Cretaceous to Miocene. These garnet deposits were then exposed on both sides of the rift and within the Basin and Range by block-faulting.

Late Paleozoic (Pennsylvanian through Permian) rocks are the predominant host rocks for the garnet skarns. The entire Paleozoic section lies unconformably on a metamorphosed, crystalline basement of late Proterozoic rocks. The lower Paleozoic section is dominated by dolomites and clastic sedimentary rocks. The upper Paleozoic is composed of shelf carbonates which progressively give way to clastic rocks at the top of the section. The Paleozoic section tends to thicken east and west of a paleohigh in southwestern New Mexico (Wilson, 1989, fig. 2). Most of the Mesozoic section represents a period of deposition of terrigenous clastic rocks except for marine incursions

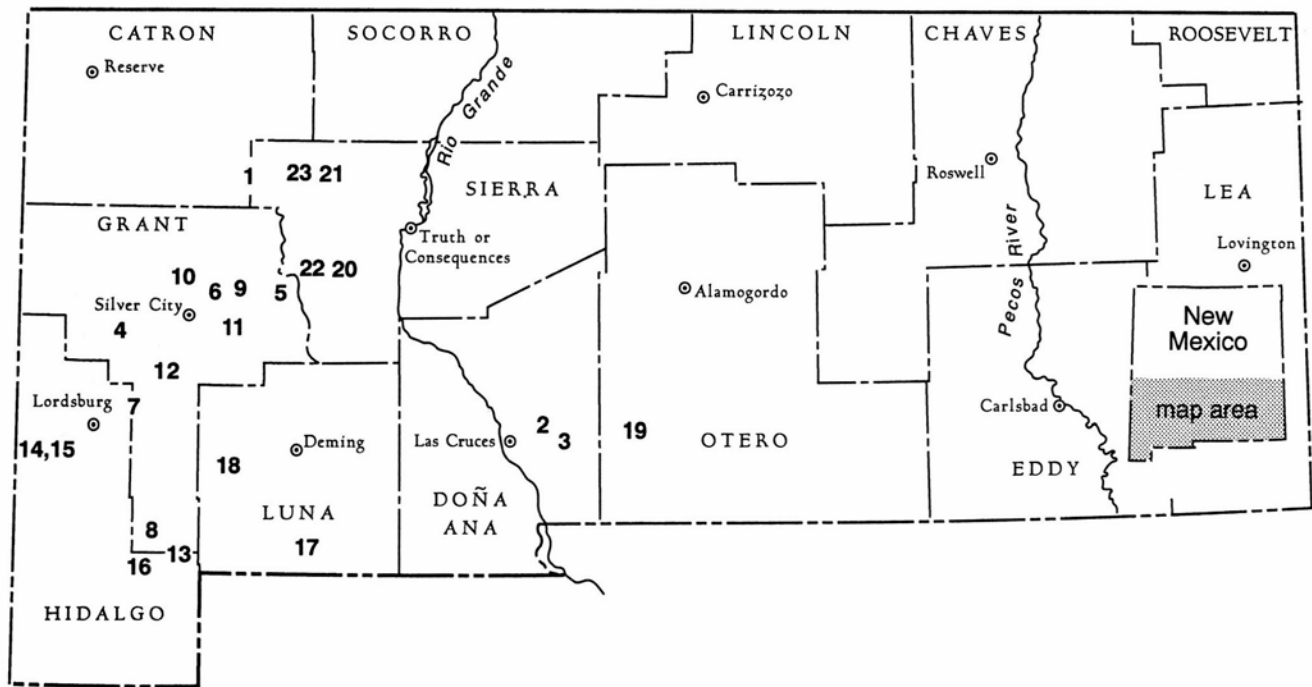

FIGURE 1—Location map of garnet occurrences in southern New Mexico. Numbers correspond to locations on Table 1.

TABLE 1—Garnet occurrences and host rock lithologies in southern New Mexico.

County	District/locale	Garnet occurrence	Skarn type	Garnet composition	Host rocks	Reference
<i>Catron</i>						
1	Taylor Creek	Veins	NA	Sp (?)	Rhyolite flows	Northrup, 1959
<i>Doña Ana</i>						
2	Organ	Skarn	Copper, lead-zinc	An-Gr	uPz limestone	Lueth, 1984; Dunham, 1935
3	South Canyon	Skarn	Reaction	Uv	Xenolith	Dunham, 1935
<i>Grant</i>						
4	Bullard Peak	Pegmatite	NA	Sp <sub>65</sub> Al <sub>25</sub> Gr <sub>10</sub>	p schist	Hewitt, 1959; Gillerman, 1964
5	Carpenter	Skarn	Lead-zinc	An(?)		Kuellmer, 1954
6	Copper Flat	Skarn	Zinc	An <sub>0-100</sub> Sp <sub>0-10</sub>	uPz limestone	Lueth, 1984
7	Gold Hill	Pegmatite	NA	Alm or Sp (?)		Gillerman, 1964
8	Eureka	Skarn	Copper	An (?)		Laskey, 1947; Zeller, 1970
9	Fierro-Hanover	Skarn	Iron, lead-zinc	An <sub>0-100</sub> Sp <sub>10</sub>	uPz limestone	Lueth, 1984; Turner, 1985; 1990
10	Pinos Altos	Skarn	Copper, lead-zinc	An <sub>0-100</sub> Sp <sub>0-5</sub>	uPz limestone	Lueth, 1984
11	Santa Rita	Skarn	Porphyry copper	An <sub>0-100</sub>	uPz limestone	Lueth, 1984
12	White Signal	Dike, placer	Reaction	Alm (?), Py	p schist	Gillerman, 1964
<i>Hidalgo</i>						
13	Apache No. 2	Skarn	Copper	An (?)	uPz limestone	Peterson, 1976
14	Granite Gap	Skarn	Lead-zinc	An (?)	uPz limestone	Northrup, 1959
15	McGhee Peak	Skarn	Copper, lead-zinc	An (?)	uPz limestone	Richter and Lawrence, 1983
16	Sylvanite	Skarn	Lead-zinc	An (?)	uPz limestone	Northrup, 1959
<i>Luna</i>						
17	Tres Hermanas	Skarn	Lead-zinc	An (?)	uPz limestone	Griswold, 1961
18	Victorio	Skarn	Tungsten	An (?)	lPz limestone	Griswold, 1961
<i>Otero</i>						
19	Orogrande	Skarn	Copper	An <sub>0-100</sub> (?)	uPz limestone	North, 1981
<i>Sierra</i>						
20	Hillsboro	Skarn	Porphyry copper	An (?)	uPz limestone	Dunn, 1982
21	Iron Mountain	Skarn	Iron	An <sub>0-100</sub> (?)	uPz limestone	Kuellmer, 1954
22	Kingston	Skarn	Lead-zinc	Gr (?)	uPz limestone	Harley, 1934
23	Chloride	Skarn	Copper, lead-zinc	Gr (?)	uPz limestone	Harley, 1934

**Abbreviations:** NA—not applicable, Alm—almandine, An—andradite, Gr—grossular, Py—pyrope, Sp—spessartine, Uv—uvarovite, C<sub>(x)</sub>—mol percent end member component, (?)—exact composition not determined, p—Precambrian, lPz—lower Paleozoic, uPz—upper Paleozoic

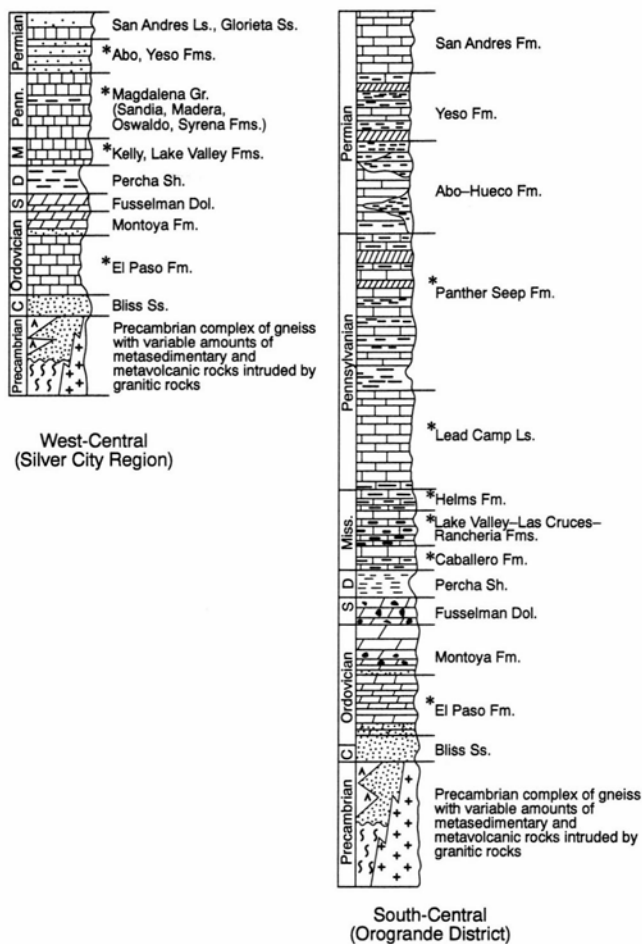

FIGURE 2—Generalized Paleozoic stratigraphy across southern New Mexico. The upper Paleozoic section thickens west of the Silver City region. Asterisks (\*) represent garnet-host formations. Modified from New Mexico Geological Society (1982), used with permission.

of Cretaceous age. The Cenozoic section is dominated by volcanic rocks and their volcanoclastic equivalents that cover older rocks in many areas. Neogene basin-fill deposits in rift basins may locally conceal the garnet deposits that developed prior to regional extension.

The skarn host rocks are predominantly normal-marine, shallow-shelf limestones (Fig. 2). In the southwestern portion of the state, the Lake Valley (Mississippian), Oswaldo (Pennsylvanian), Syrena (Pennsylvanian) and to a limited extent the Abo (Permian) Formations serve as host rocks to skarn mineralization. In the eastern region, the Caballero (Mississippian), Lake Valley (Mississippian), Gobbler (Pennsylvanian), Lead Camp (Pennsylvanian), Panther Seep (Pennsylvanian), and less commonly the Abo-Hueco Formations (Permian) host extensive skarn deposits.

Igneous rocks intimately associated with skarn formation are typically polyphase granitic stocks. The intrusive rocks are similar among all deposits. Most are granodiorite to granite and are typically porphyritic. The mode of intrusion varies from forceful to passive. Passive emplacement by magmatic stoping is common and results in the formation of roof-pendant skarns within the main intrusive mass in some districts. Pre-mineralization structures and lithologies also exert strong control on the distribution of the skarn and metal-ore mineral formation by controlling fluid flow in the intrusive and host rocks.

## Skarn mineralization

Investigators have recognized three distinct stages of skarn evolution defined by textural and mineralogical patterns (Einaudi et al., 1981). These stages consist of: (1) an early isochemical contact-metamorphic mineral assemblage associated with initial magma emplacement; (2) a metasomatic, main skarn-forming stage associated with exsolution of magmatic fluids and an influx of meteoric water into the intrusion; and (3) a retrograde alteration stage dominated by the formation of hydrous mineral phases and extensive sulfide deposition. Garnet forms during the contact-metamorphic and metasomatic stages of skarn development. Usually garnets are partially or completely destroyed during the retrograde stage.

Most modern workers classify skarns according to dominant metal production (e.g. Einaudi et al., 1981). This paper follows the modern classification of Einaudi et al. (1981). In addition, the discussion is restricted to deposits hosted by limestones (calcic skarns) and omits dolomitic host rocks (magnesian skarns) that typically do not contain garnet. A structural classification is also required in order to describe the location of the skarn mineralization relative to their intrusive rocks. Skarns which develop immediately adjacent to plutons are termed proximal skarns. Those that form along faults or dikes, away from a large intrusive mass, are called distal skarns. Proximal, calcic, iron-copper-zinc-tungsten skarns are emphasized because they are most common in southern New Mexico.

## Skarn development and garnet characteristics

The composition and textural characteristics of garnet are unique to each stage of the skarn-forming process. Grossular ( $\text{Ca}_3\text{Al}_2\text{Si}_3\text{O}_{12}$ ) and andradite ( $\text{Ca}_3\text{Fe}_2\text{Si}_3\text{O}_{12}$ ) are the two most common types of garnet found in skarn. A complete solid solution exists between grossular and andradite. Intermediate compositions that fall within the solid solution endmembers are termed grandite. In general, the early stages of skarn growth are typified by grossular-rich grandite garnets. As skarn formation continues, the garnets become more andradite-rich. However, the changes in composition are not necessarily linear. In fact, garnet compositions often show oscillatory zoning that may reflect a number of variables in the skarn system, such as (1) compositional variations in the mineralizing fluid (Tracy, 1982) or (2) changing  $P_{\text{CO}_2}$  conditions (Lee and Atkinson, 1985).

The skarn protolith exerts strong control over the mineralogy of the skarn and the distribution of the minerals (Table 2). In southern New Mexico, the typical skarn host rocks grade from pure limestone to calcareous shale, and in some instances, dolomitic limestone. Alumina-rich rocks, such as shale, tend to form calcium-aluminum silicates of fine-grained textures (hornfels), which greatly inhibits fluid flow through the rocks. However, the hornfels tend to be brittle and are often strongly fractured. Pure limestone produces coarse-textured calc-silicate minerals whose distribution is controlled by both initial porosity in the host rocks and secondary permeability developed during mineralization, and, to a lesser degree, by fracture-induced permeability.

Skarns are typically zoned with respect to mineralogy. This zonation is sequential and characteristically develops away from the skarn fluid-source regions, usually intrusives. The general pattern consists of a garnet-rich zone adjacent to the intrusive, grading outward through a garnet-clinopyroxene zone to a pyroxene zone and fi-

TABLE 2—Calc-silicate mineralogies associated with various host-rock lithologies and skarn grown stages in southern New Mexico.

Host rock	Metamorphic stage	Metasomatic stage	Retrograde stage
Siltstone	Quartz		Quartz
	Calcite	Chlorite	Epidote
	Diopside	Diopside	Calcite
	Chlorite	Grossular-andradite	Chlorite
	Muscovite	Siderite	Sulfide
	Biotite Albite Feldspar		Clay
Silty limestone and calcareous siltstone		Andradite	Actinolite
	Calcite	Diopside	Epidote
	Quartz	Tremolite	Clay
	Diopside	Calcite	Zeolite
Limestone		Quartz	Calcite
	Calcite	Magnetite	Sulfide minerals
		Grossular-andradite	Quartz
	Wollastonite	Diopside	Chlorite
Calcareous siltstone		Wollastonite	Siderite
	Grossular	Sericite	Gypsum
	Tremolite	Feldspar	Ankerite
	Vesuvianite	Sulfides (rare)	Sericite

nally to marble (Fig. 3). The zonation is probably caused by temperature and pressure gradients and chemical-reaction fronts (associated with variations in oxidation state, initial fluid composition, wall-rock composition, or water/rock ratio; Meinert, 1987). The pattern varies according to composition of the protolith, permeability of the host rock, and the presence or absence of fractures.

**Contact-metamorphic stage**—The initial skarn stage in most deposits is characterized by a mineral assemblage of marble in pure limestone accompanied by wollastonite in limestones that contain chert (e.g. Lake Valley Formation). Impure limestone units (e.g. Oswaldo Formation) usually contain wollastonite, vesuvianite, grandite (<Ad<sub>50</sub>), and diopside pyroxene. Bulk chemical composition of the host rocks does not change except for a loss of water and carbon dioxide. Accordingly, the composition of the minerals themselves tends to be uniform, and they lack growth zoning. Grandite compositions reflect the **iron concentra-**

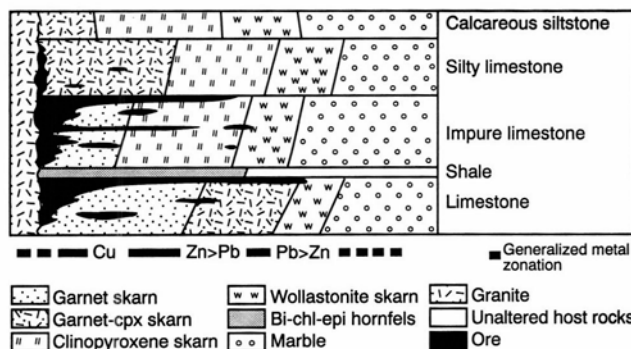
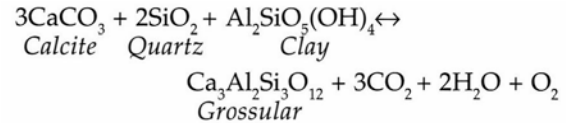

FIGURE 3—Generalized pattern of skarn zonation in southern New Mexico. Lithologies correlate to actual stratigraphic sequence in the Silver City region.

tions originally in the rocks. A typical garnet-producing metamorphic-stage reaction includes:



Garnet does not commonly replace entire beds, in fact the mineral is usually dispersed in the thermal-stage rocks. The grains are commonly euhedral and contain sparse inclusions of quartz, clay, calcite, wollastonite, and occasionally tremolite (Fig. 4A).

**Metasomatic stage**—The second stage of skarn development is characterized by wholesale changes in the bulk chemistry of the host rocks, termed the exoskarn. A relatively simple assemblage of iron-rich grandite, hedenbergitic to diopside pyroxene, and iron oxides develops in most garnet skarns. The iron oxides can be magnetite or hematite depending on the oxidation state of the metasomatic fluid during this stage of skarn growth. Garnet-producing metasomatic reactions include:

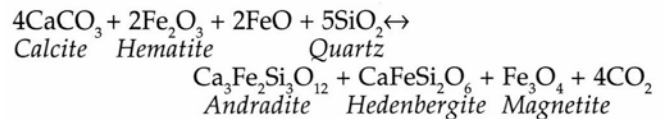
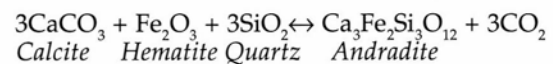
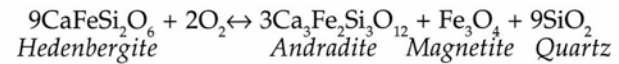

The fluids responsible for the metasomatism of the carbonates are thought to be of magmatic origin, although some workers report, based on stable-isotope data, that magmatic fluids are not necessary (Turner, 1990). "Typical" fluids in equilibrium with granite are neutral to acidic and enriched in iron relative to magnesium (Whitney et al., 1979). Over time, these magmatic fluids appear to become more iron-rich and begin to incorporate a greater amount of meteoric water (Einaudi et al., 1981). The greatest changes in bulk chemistry are increases in iron, silica, and aluminum coupled with decreased calcium. An endoskarn may develop on the margins of the pluton, characterized by calcium metasomatism. Metasomatic reactions in the endoskarn can produce a rock identical to those of the exoskarn. The development of endoskarn appears to be a major factor in discriminating between skarn types. Garnet textures are highly variable during this stage of skarn growth. Previously formed, isotropic and euhedral grossularitic grandite is often mantled by anisotropic andradite (Fig. 4B). Andradite can form massive material along veins and veinlets (Fig. 4C). Massive, granoblastic garnet replacements up to 1 m thick also occur in some deposits (Fig. 4D). Grain sizes can vary from microns to tens of centimeters. Garnets can vary from euhedral to anhedral within a single thin section.

**Retrograde stage**—The final stage of skarn development is characterized by the decomposition of the higher-temperature skarn stages. Metallic-ore deposition is thought to commence during the latest stages of the metasomatic growth episode and continue throughout the retrograde stage. Mineralogy of this stage is characterized by the de-

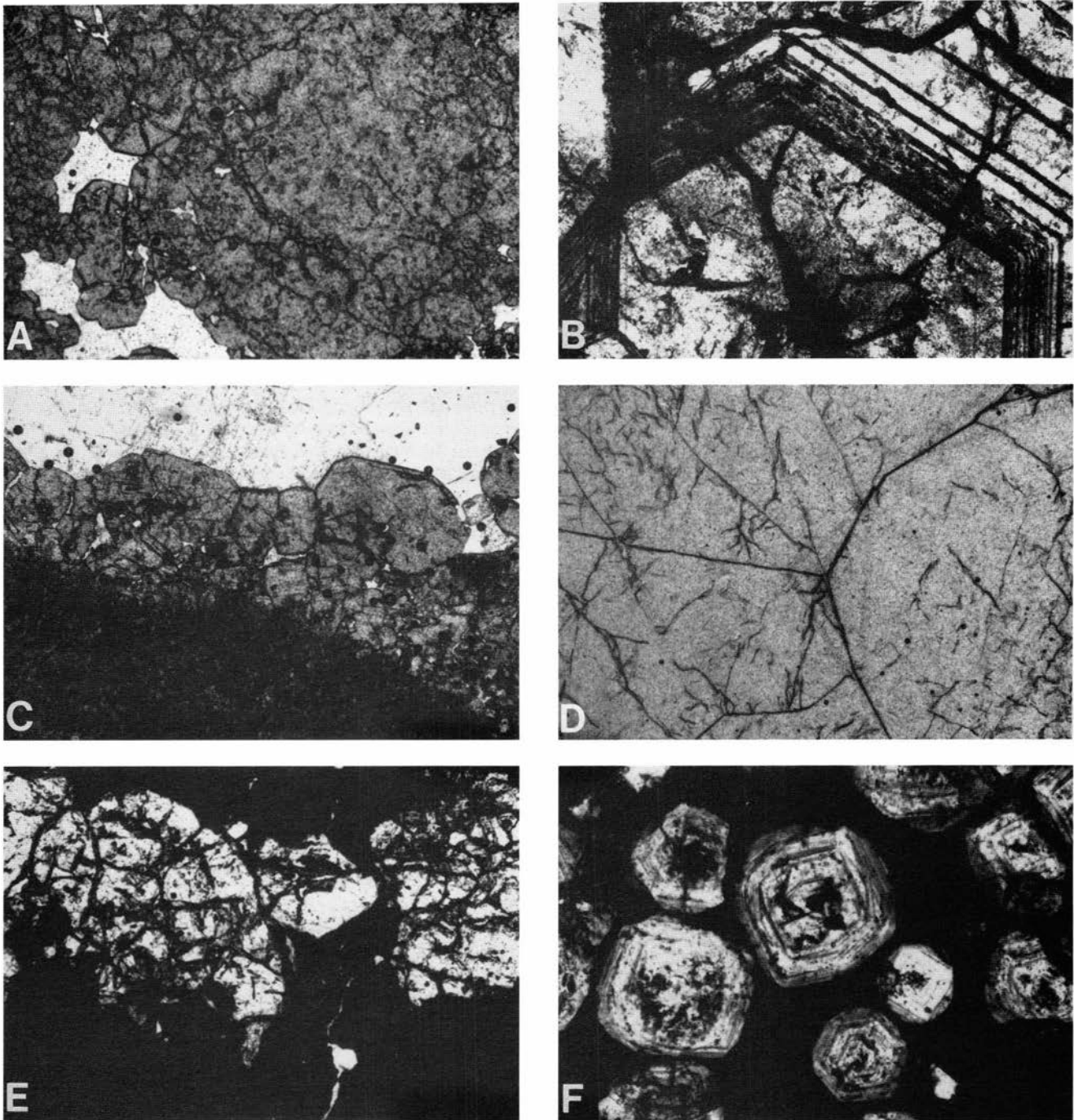
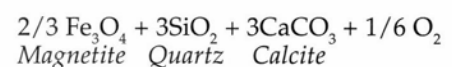
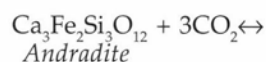
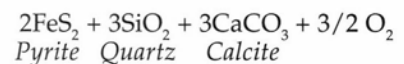
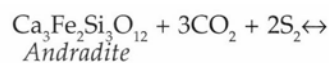

FIGURE 4—Photomicrographs of various garnet textures. The long dimension represents 2.5 mm on all photographs. All photomicrographs in plane polarized light. **A**, Grossular garnet with mineral inclusions of calcite and diopside (Cyprus mine, Pinos Altos). **B**, Anisotropic andradite garnet overgrowth on isotropic grossular core (Cobre mine, Hanover-Fierro). **C**, Andradite garnet lining a quartz-calcite vein (Cyprus mine, Pinos Altos). **D**, Massive, granoblastic andradite (Chino mine, Santa Rita). **E**, Garnet replaced by sulfides. Calcium-depleted silicates replace garnet along fractures and growth planes (Cobre mine, Hanover-Fierro). **F**, Garnets "floating" in sphalerite (Empire mine, Hanover-Fierro).

velopment of hydrous minerals such as smectite clays, epidote, actinolite, and ferrotremolite. Retrograde reactions involve the replacement of a calcium-rich assemblage with calcium-depleted silicates, iron oxides, carbonate minerals, and albitic plagioclase. Extensive retrograde destruction of skarn minerals, especially garnet, is most common in porphyry copper skarns and most limited in iron skarns. Mainly the alteration is seen as sulfide or silicate (calcium-depleted) replacement of grains (Fig. 4E). Some of these retrograde reactions include:





Retrograde alteration is usually confined to fault zones or specific fluid pathways (i.e. permeability zones) in the skarn. However, garnet can be stable under special conditions within the retrograde phase (Einaudi, 1982). When present as a stable phase however, garnets are often euhedral or slightly corroded and seen "floating" in sulfide ore (Fig. 4F).

### Skarn types and garnet character

Previous workers (Einaudi et al., 1981; Einaudi and Burt, 1982; Meinert, 1983; Meinert, 1989) recognized particular textures and compositions unique to each type of skarn. The following discussion elaborates on the various features of each skarn type utilizing the classification system of Einaudi et al. (1981). Special attention is paid to garnet composition and textures as they are represented in the deposits studied in New Mexico.

### Iron skarn

True iron skarns are uncommon in southern New Mexico. Calcic iron skarns and similar gold skarns (Meinert, 1989) are most often located proximal to epizonal diorite plutons and near subduction zones. They are characterized by an iron-rich gangue assemblage of epidote, andradite garnet, and ferrosilite. The pluton is extensively altered during the retrograde mineralization stage to epidote and iron pyroxene. Little sulfide mineralization accompanies skarn formation. Two distinct compositional groups of garnet are recognized, one early formed grossular-rich grandite followed by andraditic grandites. Andradite garnet comprises up to 95% of the total garnet species. One of the best examples of an iron skarn found in southern New Mexico is the Iron Mountain district in the Cuchillo Mountains of Sierra and Socorro Counties. Although tungsten minerals are also present in late stage and localized portions of the Iron Mountain district, much of the mineralization is typical of iron skarns. Iron skarns are also present around the margins of the Hanover—Fierro pluton in Grant County. Classification and characterization of the iron skarns in the Hanover—Fierro district are complicated by the complex overlapping nature of multiple types of mineralization (e.g. copper, zinc, and iron skarns and vein deposits). Because iron was the predominant metal produced in some mines at Hanover—Fierro, the deposits are treated as iron skarn in this report.

The iron skarn deposits at the Iron Mountain district are large and extensive. Jahns (1944) reported skarn layers up to 30 m thick with lateral exposures of up to 3 km. The skarn consists mainly of magnetite and andradite garnet hosted by Magdalena Group limestones (Kelly, 1949). Hedenbergite and specularite are locally abundant in the skarn layers. The skarn is in contact with an aplitic granite and is best developed adjacent to sills. The intrusive rocks show very little endoskarn development. Skarn mineralization is preferentially confined to tabular replacements in the impure carbonate units. Fractures and original permeability appear to have exerted strong control over the replacement process. Garnet units tend to be distributed distal to the magnetite replacements most of which are immediately adjacent to the intrusive rock. Some layers (up to 1 m thick) are pure andradite, although most of the deposits average 70% garnet (Jahns, 1944). Retrograde alteration accompanies the limited tungsten mineralization, mainly as vein and veinlets. The alteration assemblage consists of fluorite, apatite, actinolite, quartz,

chlorite, scheelite, powellite, and sulfides. The Iron Mountain district represents a vast garnet deposit exposed at the surface and of relatively high grade.

Iron skarns in the Hanover—Fierro district, Grant County, are hosted throughout the entire Paleozoic section (Kelly, 1949). The largest iron deposits are found in lower Paleozoic dolomitic units which contain very little garnet. Deposits located in the upper Paleozoic section contain significant garnet and constitute potential ore. Iron mining usually bypassed the most garnet-rich layers and many still remain today as ribs at the surface. Most of the iron mining was accomplished at the surface or as inclines following magnetite replacements down-dip. As is common in the district, the best garnet beds are generally found in the Lake Valley Formation. At the El Paso mine, massive pure-garnet layers are up to 4 m thick in addition to 8 m thick layers of garnet—epidote rock averaging over 60% garnet (Yousefpour, 1979). Similar deposits of mixed garnet—epidote rock occur at the Cupola mine, Robert E. Lee mine, and the Santa Fe #1 claims, all hosted by the Oswaldo Formation. A 1-3 m thick garnet bed is reported at the Snowflake mine over a mapped distance of 180 m (Kelly, 1949).

### Copper skarn

Copper skarns are the most abundant type in southern New Mexico. They are characteristically associated with epizonal granitic stocks. Copper skarns tend to be proximal to stocks, contain high garnet-to-pyroxene ratios, and consist of oxidized mineral assemblages. Mineralization patterns are broad, yet vary considerably in vertical aspect because of lithologic variation within the protoliths. Garnets display a significant grossular component, up to 20 mol %, although purer andradite is the most common type. Retrograde alteration is more extensive in some deposits, especially those associated with porphyry copper systems (e.g. Santa Rita). Sulfide mineralization can be extensive, and is characterized by an intermediate sulfidation assemblage of pyrite—chalcopyrite, tennantite, and sphalerite. The metal suite tends to be very complex in these skarn types. Some workers have proposed that skarns associated with porphyry copper deposits be classified separately from those associated with barren stock copper deposits (Einaudi et al., 1981). Porphyry-related skarns are volumetrically larger and contain significant retrograde alteration in complex patterns and higher sulfide concentrations (Lueth, 1984). However, calc-silicate mineralogy is roughly similar except that garnet and pyroxene compositions generally contain higher iron content in porphyry types. Because the compositions and mineralization patterns are grossly similar, porphyry-related and copper skarn deposits are considered together in this paper.

Very large garnet deposits are visible today in the active copper mines at Santa Rita (Chino mine), Cobre (formerly the Continental mine at Fierro), and the Pinos Altos Cyprus mine. The garnets at these localities have been studied in detail by Lueth (1984). Specific mineralization patterns are similar to most skarn deposits in southern New Mexico. The purer limestone units host the best garnet deposits with respect to purity and volume, whereas the less pure limestone units contain more pyroxene with the garnet. Garnet replacement is massive in these deposits, especially nearest the intrusive rocks. However, brecciation and sulfide mineralization are also strongest in the garnet zones. This is in contrast to metal mineral-



ization in the iron and lead-zinc skarn deposits. Retrograde alteration of garnet is common, especially in proximity to sulfide mineralization and fault zones.

Garnets are also common in less-well-characterized districts. Large skarn replacements are present at the Apache No. 2, Organ, Eureka, and San Simon districts (Fig. 1 and Table 1). However, many of these districts have been inactive for a long time and the geology has been poorly evaluated with respect to garnet potential. Most of the workings are collapsed or in dangerous condition. Although long idle, the Orogrande district in Otero County represents a well-exposed example of a small copper mineralization system with associated skarn development. Most of the workings are open cuts at the surface and much ore is exposed. Exploration in this district, along with detailed study of garnet mineralization, could provide an excellent model for similar deposits throughout southern New Mexico.

Two types of garnet are typically observed in copper skarns. An isotropic, grossular-rich grandite and anisotropic, andradite-rich type. The grossular garnets tend to be isolated or occur as cores in large garnets mantled by anisotropic andradite (Fig. 4B). Andradite garnet is commonly found mantling veins and in massive bed replacements. All garnet types typically contain inclusions of previously formed minerals (calcite, wollastonite, pyroxene, quartz). Fractures in garnets are typically altered to calcite, actinolite, or clay. Preservation of thermal-phase garnets is most common in the smaller skarn deposits and not often observed in porphyry systems. In porphyry copper deposits the mineral zonation is broader and retrograde effects all much stronger. In some areas, calc-silicate mineralogies are completely obliterated.

### Lead-zinc skarn

Lead-zinc skarns, in contrast to copper types, are not always directly associated with plutons. Structural and lithologic controls appear to greatly influence mineralization patterns. Zinc skarns are found in two distinct structural settings, proximal to plutons and along faults. The skarns proximal to plutons contain the most garnet. Limited skarn mineralization is characteristic of fault-controlled skarns. Zinc skarns also contain a high pyroxene to garnet ratio. The calc-silicate assemblage often consists of Mn- and Fe-rich mineralogies, indicated by significant johannsonite components in pyroxene, andradite to grossular garnets with significant spessartine components, and the presence of ilvaite. Retrograde alteration is limited. Sulfide mineralization is characterized by sphalerite, galena, pyrite, and pyrrhotite. Compositional variation of garnet and pyroxene is fairly significant in these deposits.

The southern portion of the Hanover-Fierro district and the eastern portion of the Central district are two of the most strongly zinc-mineralized skarn areas in the state. Proximal zinc skarns occur around the southern, equigranular lobe of the Hanover-Fierro pluton and distal skarn types occur along southwest-trending faults and dikes in the Central district. Skarn mineralization is strongly zoned and limited in extent around the fault-controlled deposits (e.g. Ground Hog mine; Meinert, 1987). Extensive calc-silicate mineralization occurs around the Hanover-Fierro pluton, best studied at the Empire (Turner, 1990) and Pewabic (Schmitt, 1939) mines. Sphalerite mineralization was strongly influenced by the presence of pre-ore dikes. Metal mineralization tends to be distal in contrast to garnet that is nearest to the intru-

sive and relatively unmineralized. Sphalerite mineralization is confined mainly to the pyroxene-garnet zones outward from the garnet zone. Most of the mine workings do not penetrate large areas of the garnet rock. The garnet in these deposits is anhedral to euhedral andradite ranging in size from <1 mm to 1 cm. Two distinct occurrences of garnet are present, (1) larger-sized, unzoned grossularitic garnets, and (2) zoned andradite garnets that comprise the largest volume. The zoned garnets tend to contain quartz inclusions and may have pyroxene inclusions in the outer layers. Mining techniques are similar to those employed in the iron skarns. Large layers of almost pure garnet were left behind in the pursuit of sphalerite ore. At Hanover-Fierro the best garnet units adjacent to the pluton were undisturbed during mining and remain accessible from the mine workings.

### Tungsten skarn

Associated with coarse-grained granites, tungsten skarns are the least common type in New Mexico. The calc-silicate assemblage is dominated by garnet and pyroxene which grade away from the intrusive contact to wollastonite and idocrase. Retrograde alteration is limited and sulfide assemblages are characterized by more reduced assemblages compared to the other skarn types. In general, tungsten skarns represent higher temperature and pressure conditions of mineralization.

The only tungsten skarn in southern New Mexico is in the Victorio district, Luna County. The Tungsten Hill area of the Victorio district is where tungsten and beryllium minerals are hosted by rock described by Griswold (1961) as "tactite." Skarn mineralization is localized on the southern limb of an east-trending syncline where alkali-granite porphyry intrudes the Montoya and El Paso Formations of Ordovician age. The skarn zones are irregular pods that consist of grossularite, tremolite, diopside, idocrase, and phlogopite with minor amounts of quartz and fluorite. Only two bands of skarn are present, of which the largest has an exposure of 6 x 60 m; it is hosted by the El Paso limestone at the Tungsten Hill shaft. The second band has an exposure of 3 x 150 m long and is in the Montoya dolomite 120 m north of the Tungsten Hill shaft. Grossularite comprises a small percentage of the "tactite." The limited outcrop of skarn in this district obviously makes development of garnet orebodies prohibitive, although the garnet is grossular. Buried skarn may occur in the district; magnetic surveys would be useful in this determination, but the added costs may make development of the Tungsten Hills skarns prohibitive.

### Economic feasibility

To the author's knowledge, an economic evaluation of skarn garnet deposits in southern New Mexico has not been published. To evaluate the deposits of this region, the criteria presented by Austin (1994a) are used; they include (1) size and grade, (2) mining conditions, (3) quality of the garnet, (4) location relative to markets, and (5) milling costs. This presentation of economic feasibility is a general overview. Evaluation of any specific deposit has not been attempted.

### Size and grade

Sizes and grades of garnet deposits vary significantly. Some of the deposits mentioned are of immense size and high grade. The deposits at Iron Mountain, Hanover-Fierro (all skarn types), Santa Rita, and Orogrande all qualify for feasible mining based on size and grade of the garnet. Con-

sistent grades can be maintained if mining is done along strike of a favorable horizon.

### Mining conditions

All skarn deposits mentioned in this paper were mined in the past for base or precious metals. Large, open-cut or pit methods, which represent the lowest mining cost, were employed at several of the largest deposits. Much of the best garnet material, which contains the least metal ore and the lowest concentrations of potential contaminants, was left in place or separated preferentially as waste rock at the time of initial mining. Large, pre-mined garnet "ore piles" are present at Hanover—Fierro (all skarn types) and Orogrande. Large "ribs" of pure garnet are also present at many mining districts, with pre-existing workings intact.

### Quality of garnet

The quality of skarn garnets in the study area is the most pressing aspect of evaluation of these deposits. Grandite-series garnets have a high degree of variation in their composition, texture, and physical properties. Grossular and andradite have Mohs hardnesses of 6.5-7.5 and 6.5-7.0, respectively. They tend to be less hard than the "industry standard" almandine garnet (Mohs hardness of 7.0-7.5 with reported hardness up to 9.0; Austin, 1994a). Specific gravity within the grandite series varies between 3.53 (grossular) and 3.75 (andradite), which is lower than the specific gravity of almandine (4.25). Variation of crystal habit within a deposit is also accompanied by variation in fracture characteristics that can vary from conchoidal to uneven and may include the presence of a parting in some grains. Although grandite garnets do not measure up to almandine "standards," it is important to note that there are no garnet industry standards. Grandite hardness, fracture, and friability are competitive with alternative abrasives such as slags, manufactured abrasives, silica sand, olivine, and staurolite. Testing of individual garnet deposits should employ the methods outlined by Austin (1994a).

In order to successfully develop these deposits, a detailed study of garnet geochemistry, texture, and product feasibility (angularity, hardness, and resistance to abrasion) will be required. The evaluation of product feasibility must be done to specific target zones within the skarn system because garnet characteristics vary within a single deposit. The best garnet units should display a massive granoblastic texture and maintain a consistent (mainly andradite-rich) chemical composition. Care should be taken to avoid garnets that contain abundant inclusions, which have a deleterious affect on the abrasive quality of the material. The most favorable horizons of garnet in deposits of southern New Mexico will be found in the purest limestone protoliths. In addition, the largest volume of uniform garnet mineralization will be in limestones adjacent to zones of low permeability (i.e. shale partings or pre-mineralization dikes).

The proximity of these garnets to metallic minerals also calls into question the trace-element compositions of the product. Garnet mined from metallic-ore zones can be expected to have significant trace-metal contamination (see Cetin et al., this volume). Avoiding zones of retrograde alteration and known sulfide mineralization will assure chemical purity of the garnet product. This is why it is less feasible to process garnet from tailings and why greater emphasis should be placed on unprocessed waste piles. Tailings represent garnet taken from ore zones,

which would be most contaminated. Waste rock, which contained little ore, could be high-grade garnet ore.

### Location to markets

Potential markets for abrasive garnets used in sandblasting (mainly as ship cleaning) are located about 1,300 km west and east of New Mexico. The seaports of California and Texas are all linked to New Mexico by railroad or interstate highway. Marketing to large manufacturing industries in these states could also be fruitful. In addition, large population centers that may require large-scale water-filtration facilities exist near New Mexico in Arizona, California, Colorado, and Texas. The mining infrastructure of the region and the accompanying transportation network would make New Mexico garnet very competitive in the largest markets.

### Milling costs

Significant variations in garnet quality within a single skarn deposit suggest that milling procedures may be the most significant determinant in the economic development of these deposits. Two problems in milling can be anticipated: (1) size fractionation and (2) attaining desired purity of garnet product. The non-uniform compositions of skarn garnets coupled with their variable textures and the occurrence of mineral inclusions may impose some milling problems. These can be alleviated by the selection of favorable garnet zones with more uniform physical and chemical characteristics. Purity of the product, both in product composition and trace-element contents, represents another consideration. Gravity separation, followed by magnetic-separation technology, appears to be the most efficient method of grain separation (up to 95% in studies of similar skarns by Mathieu et al., 1992). If the separation of garnet is as selective as reported by Mathieu et al. (1992), different quality grades of garnet may be possible from a single deposit. These grades would consist of a large volume of lower-quality andradite-rich material and a smaller amount of higher-quality grossular. If a uniform calc-silicate mineral separation can be accomplished, the variability of grandite compositions should not be a significant factor in the end-use application of the product. Sandblasting, filtration media, or abrasive cutting material would all be within a specific range of characteristics, although not absolutely uniform (as might be the case with a single species of garnet). Avoiding metal-mineralized areas (usually indicated by the degree of retrograde alteration) represents the best method for maintaining trace-element purity. Additional methods of separation for metallic minerals (i.e. flotation) would probably make development costs prohibitive.

### Conclusions

A survey of the various types of skarn deposits in southern New Mexico indicates that significant garnet deposits are present in the study area. Iron skarns represent the most favorable targets with respect to garnet compositional purity and textural characteristics. Porphyry copper skarns have good potential because of their large size, although extensive alteration and metal contamination of the product may render garnet recovery too expensive. Likewise, lead—zinc skarns represent good targets for development, although metal contamination is a concern near areas of metal mineralization. Exploration for garnet in lead—zinc skarns should be confined to proximal skarns and zones immediately adjacent to the intrusive. Garnet exploration

in copper skarns should concentrate on the Lake Valley Formation, away from post-mineralization faults. Within many of the small districts of the region, large deposits of relatively pure garnet remain in place, bypassed by metal mining. These represent the best mining potential for garnet if processing technology can make grandite-series garnets competitive in the marketplace.

### Acknowledgments

Constructive reviews of the manuscript were provided by Richard Chamberlain and Virginia McLemore (New Mexico Bureau of Mines and Mineral Resources, NMBMMR). Figures were drafted by the Cartography Department of the NMBMMR. This work was supported by the NMBMMR (Charles E. Chapin, Director and State Geologist).

### References

- Austin, G. T., 1994a, Blasting abrasives in the United States market: Society for Mining, Metallurgy, and Exploration Inc., Littleton, Colorado, Preprint Number 94-11, 9 pp.
- Austin, G. T., 1994b, Garnet; *in* Carr, D. D. (ed.), *Industrial minerals and rocks: Society of Mining, Metallurgy, and Exploration Inc., Littleton, Colorado*, pp. 523-533.
- Cetin, U., Walder, I. F., Lueth, V. W., and Gundiler, I. H., this volume, Recovery of garnet from mill tailings, Grant County, New Mexico, USA: New Mexico Bureau of Mines and Mineral Resources, Bulletin 154.
- Dunham, K. C., 1935, The geology of the Organ Mountains: New Mexico Bureau of Mines and Mineral Resources, Bulletin 11, 270 pp.
- Dunn, P. G., 1982, Geology of the Copper Flat porphyry copper deposit, Hillsboro, Sierra County, New Mexico; *in* Titley, S. R. (ed.), *Advances in the geology of the porphyry copper deposits, southwestern North America: University of Arizona Press, Tucson, Arizona*, pp. 313-326.
- Einaudi, M. T., 1982, Skarns associated with porphyry copper deposits. I. Description of deposits, southwestern North America, II. General features and origin; *in* Titley, S. R. (ed.), *Advances in the geology of the porphyry copper deposits, southwestern North America: University of Arizona Press, Tucson, Arizona*, pp. 139-183.
- Einaudi, M. T., and Burt, D. M., 1982, Introduction-Terminology, classification, and composition of skarn deposits: *Economic Geology*, v. 77, pp. 745-754.
- Einaudi, M. T., Meinert, L. D., and Newberry, R. J., 1981, Skarn deposits; *in* Skinner, B. J. (ed.), *Economic Geology, 75th Anniversary Volume: The Economic Geology Publishing Company, El Paso, Texas*, pp. 317-391.
- Fattah, H., 1994, Royalstar Resources lead garnet pack: *Industrial Minerals*, no. 320, pp. 48-49.
- Gillerman, E., 1964, Mineral deposits of western Grant County, New Mexico: New Mexico Bureau of Mines and Mineral Resources, Bulletin 83, 213 pp.
- Griswold, G. B., 1961, Mineral deposits of Luna County, New Mexico: New Mexico Bureau of Mines and Mineral Resources, Bulletin 72, 157 pp.
- Harley, G. T., 1934, The geology and ore deposits of Sierra County, New Mexico: New Mexico Bureau of Mines and Mineral Resources, Bulletin 10, 220 pp.
- Hewitt, C. H., 1959, Geology and mineral deposits of the northern Big Burro Mountains-Redrock area, Grant County, New Mexico: New Mexico Bureau of Mines and Mineral Resources, Bulletin 60, 151 pp.
- Ives, K. J., 1993, Water filtration through granular materials: *Industrial Minerals*, no. 308, pp. 41-45.
- Jahns, R. H., 1944, Beryllium and tungsten deposits of the Iron Mountain District, Sierra and Socorro Counties, New Mexico: U.S. Geological Survey, Bulletin 945-C, 79 pp.
- Kelley, V. C., 1949, Geology and economics of New Mexico iron-ore deposits: University of New Mexico, *Publications in Geology*, no. 2, 243 pp.
- Kuellmer, F. J., 1954, Geologic section of the Black Range at Kingston, New Mexico: New Mexico Bureau of Mines and Mineral Resources, Bulletin 33, 100 pp.
- Laskey, S. G., 1947, Geology and ore deposits of the Little Hatchet Mountains, Hidalgo and Grant Counties, New Mexico: U.S. Geological Survey, Professional Paper 208, 101 pp.
- Lee, C. G., and Atkinson, W. W., Jr., 1985, Geochemistry of zoned garnets from the San Pedro mine, Santa Fe County, New Mexico: *New Mexico Geology*, v. 7, pp. 69-74.
- Lueth, V. W., 1984, Comparison of copper skarns in the Silver City mining region, southwestern New Mexico: Unpublished MS thesis, University of Texas (El Paso), 179 pp.
- Mathieu, G. I., Bosclair, M. R., and Wolfe, R., 1992, Geology, mineralogy, and processing of Mount Riordan garnet ores; *in* Hora, Z. D., Hamilton, W. N., Grant, B., and Kelly, P. D. (eds.), *Industrial minerals of Alberta and British Columbia-Proceedings of the 27th Forum on the Geology of the Industrial Minerals: Alberta Geological Survey, Information Series 115*, pp. 135-145.
- Meinert, L. D., 1983, Variability of skarn deposits: Guides to exploration; *in* Boardman, S. J. (ed.), *Revolution in the Earth Sciences-Advances of the past half-century: Kendall/Hunt Publishing Company, Dubuque, Iowa*, pp. 301-316.
- Meinert, L. D., 1987, Skarn zonation and fluid evolution in the Groundhog Mine, Central Mining District, New Mexico: *Economic Geology*, v. 82, pp. 523-545.
- Meinert, L. D., 1989, Gold skarn deposits-Geology and exploration criteria: *Economic Geology, Monograph 6*, pp. 537-552.
- New Mexico Geological Society, 1982, *New Mexico Highway Geologic Map, scale 1:1,000,000*.
- North, R. M., 1981, Geology and ore deposits of the Orogrande mining district, Otero County, New Mexico: New Mexico Bureau of Mines and Mineral Resources, Open-file Report 370, 18 pp.
- Northrup, S. A., 1959, *Minerals of New Mexico, Revised edition: University of New Mexico Press, Albuquerque, New Mexico*, 665 pp.
- Peterson, S. L., 1976, Geology of the Apache No. 2 mining district, Hidalgo County, New Mexico: Unpublished MS thesis, University of New Mexico, Albuquerque, 86 pp.
- Richter, D. H., and Lawrence, V. A., 1983, Mineral deposit map of the Silver City 1° x 2° quadrangle, New Mexico and Arizona: U.S. Geological Survey, *Miscellaneous Investigations Series, Map I-1310-B, scale 1:250,000*.
- Schmitt, H., 1939, The Pewabic Mine: *Geological Society of America Bulletin*, v. 50, pp. 777-818.
- Tracy, R. J., 1982, Compositional zoning and inclusions in metamorphic minerals: *Mineralogical Society of America, Review*, v. 10, pp. 355-394.
- Turner, D. R., 1985, A petrologic and fluid inclusion study of zinc skarns of the Buckhorn Gulch area, Central mining district, Grant County, New Mexico: Unpublished MS thesis, University of Utah, Salt Lake City, 110 pp.
- Turner, D. R., 1990, Geochemistry, stable isotopes, and fluid flow of the Empire zinc skarns, Central mining district, Grant County, New Mexico: Unpublished PhD dissertation, University of Utah, Salt Lake City, 295 pp.
- Whitney, J. A., Simon, F. O., Hemley, J. J., and Davis, N. F., 1979, Iron concentrations in chlorine solutions equilibrated with synthetic quartz monzonite assemblages, Pt. 1: Sulfur free systems (abs.): *Geological Society of America, Abstracts with Programs*, v. 11, p. 563.
- Wilson, J. L., 1989, Lower and Middle Pennsylvanian strata in the Orogrande and Pedregosa Basins, New Mexico: New Mexico Bureau of Mines and Mineral Resources, Bulletin 124, 16 pp.
- Yousefpour, M. V., 1979, Genesis of skarn-polymetallic deposits in the Hanover-Fierro area and a geotechnical evaluation of pit slope stability at the Continental Mine, Fierro, New Mexico: Unpublished PhD dissertation, Colorado School of Mines, Golden, 401 pp.
- Zeller, R. A., Jr., 1970, Geology of Little Hatchet Mountains, Hidalgo and Grant Counties, New Mexico: New Mexico Bureau of Mines and Mineral Resources, Bulletin 96, 270 pp.

# Recovery of garnet from Hanover mill tailings, Grant County, New Mexico, USA

Ulvi Cetin<sup>1</sup>, Ingar F. Walder<sup>2</sup>, Virgil W. Lueth<sup>3</sup>, and Ibrahim H. Gundiler<sup>3</sup>

<sup>1</sup>Department of Mineral and Environmental Engineering, New Mexico Tech, 801 Leroy Place, Socorro, New Mexico 87801-4796, USA  
<sup>2</sup>SARB Consulting Inc., 8400 Menaul NE, #A196, Albuquerque, New Mexico 87112, USA

<sup>3</sup>New Mexico Bureau of Mines & Mineral Resources, New Mexico Tech, 801 Leroy Place, Socorro, New Mexico 87801-4796, USA

**Abstract**—The Hanover mill tailings are located in the historic Fierro–Hanover mining district east of Silver City, New Mexico, and consist of five tailings ponds. This study involves the four small ponds adjacent to Hanover Creek, which will be moved onto the largest pond east of Bull Hill, stabilized, and covered with topsoil. Recovery of garnet and sphalerite from these tailings was investigated as a potential resource to offset remediation costs. The estimated tonnage of material in the four small ponds is approximately 135,000 metric tons (mt), and the garnet content varies from 20 to 36 wt.% garnet in different size fractions. Andradite is the major garnet species and grossular is present in small amounts. Pyroxene, calcite, quartz, magnetite, and gypsum are the major components in tailings in addition to garnet. Trace amounts of sulfide minerals are present as pyrite, sphalerite, galena, and chalcopyrite.

Samples of the tailings were reground in a laboratory rod-mill to liberate individual mineral grains cemented by gypsum and to generate fresh surfaces on tarnished sulfide minerals for flotation. Lead, zinc, copper, iron, and cadmium sulfides were removed from the tailings by flotation methods and a garnet concentrate was obtained from flotation tailings by gravity concentration. Additional products of separation included a sphalerite concentrate, a coarse tailings fraction low in heavy-metal (hazardous) contaminants, and a slimes/fine tailings fraction (final tailings). Without additional treatment, the final tailings could be considered hazardous waste.

The sphalerite concentrate could be marketable, depending on the demand for concentrates by North American smelters. The marketability of the garnet concentrate for use as an abrasive or in water-filtration media is unlikely due to small particle size and impurities. However, the separation process could reduce the amount of heavy-metal contaminated fraction in the tailings by 50%. In addition, the final tailings could be rendered non-hazardous by a phosphate treatment process.

## Recuperación del granate de colas de la planta de concentración Hanover, Condado de Grant, Nuevo Mexico, E.U.A.

**Resumen**—Estos desmontes de colas están situados en el histórico distrito minero de *Fierro-Hanover* al este de *Silver City*, Nuevo Mexico y consisten de cinco estanques de decantación de colas. Este estudio trata de los cuatro estanques mas pequeños adyacentes al Arroyo de Hanover, cuyo relleno sera trasladado al mas grande de los estanques que se encuentra al este de *Bull Hill*, donde sera estabilizado y cubierto de tierra. Investigamos la recuperación de granate y esfalerita de las colas como un posible recurso para cubrir los costos de la remediación. El tonelaje de material en estos cuatro estanques se estima en 135,000 toneladas métricas y su porcentaje en peso de granate en diferentes fracciones de tamaño varia entre los 20% y 36%. Andradita es la especie predominante, con cantidades pequeñas de grosularia. Aparte del granate las especies minerales predominantes en los desmontes son piroxeno, calcita, cuarzo, magnetita y yeso. Trazas de sulfuros están presentes como pirita, esfalerita, galena y calcopirita.

Muestras de las colas fueron molidas en el laboratorio con un molino de barras (*rodmill*) para liberar granos minerales individuados cementados por yeso y para crear superficies frescas en minerales de sulfuro oxidados a los fines de su flotación. Sulfuros de plomo, zinc, cobre, hierro y cadmio fueron separados por flotación y un concentrado de granate fue obtenido de las colas de flotation mediante concentración gravitacional. Productos adicionales de separation eran un concentrado de esfalerita, una fracción gruesa que contenia bajas concentraciones de minerales de metales pesados venenosos y una fracción fina, limosa (colas finales). Sin tratamiento final, se considera que estas colas finales constituyen desechos peligrosos.

El concentrado de esfalerita podria ser comerciable, según como sea la demanda de fundiciones norteamericanas. La comercialización del concentrado de granate como abrasivo o como medio filtrante de agua es improbable debido a su tamaño de gran muy pequeños y las impurezas que contiene. Por otro lado, el proceso de separation podria reducir en un 50% la fracción de colas contaminada con metales pesados. Además, las colas finales podrian ser descontaminadas mediante un proceso de tratamiento con fosfato.

## Introduction

Tailings investigated in this study consist of five former ponds located near the unincorporated town of Hanover, 21 km east of Silver City, Grant County, New Mexico (Fig. 1). The tailings were produced at the Hanover mill by the Empire Zinc Company, a subsidiary of New Jersey Zinc Company. Most of the mine tailings are from the Empire Zinc mine that produced zinc ore from the early 1900s through the 1970s. Between 1902 and 1931 production from the Empire mine amounted to 450,000 mt of zinc ore. Smithsonite was the primary ore mineral in the early stage of mining and milling, whereas sphalerite was predominant during the later periods. The mines were closed from 1931 until 1937, and after reopening in June 1937 they remained in operation until September 1948. Approximately 113,000 mt and 1,800 mt of zinc and lead production, respectively, was credited to the Empire Zinc Company during this period (Anderson, 1957). The mine was operated briefly in 1974 by UV Industries and in 1979 was purchased by Sharon Steel. The mill also treated significant tonnages of ores from other mines in the Fierro-Hanover district (notably the Oswaldo mine) and from the Magdalena district in central New Mexico (Anderson, 1957). Currently the tailings are owned by Mining Remedial Recovery Company (MRRC) of Price, Utah. This is one of several companies created in 1992 as a result of the Sharon Steel bankruptcy resolution (ACZ Inc., 1993).

In this study, recovery of garnet and sphalerite was investigated at the four small tailings ponds (#2 through #5) located along the banks of Hanover Creek (Fig. 1). These tailings will be removed and placed on the main tailings pond (#1) located east of Bull Hill between two small tributary drainages of Hanover Creek. The total volume of the material to be removed is estimated as 75,000 m<sup>3</sup> (Table 1). Particle-size distribution, mineralogy, and chemical analysis of the tailings suggest that the tailings in ponds #2, #3, and #5 were deposited during the early years of production, probably by gravity separation. Ponds #1 (Fig. 2) and #4 (Fig. 3) were produced later during processing of sphalerite ores by flotation.

### Previous studies of the Hanover mill tailings

The Fierro-Hanover district, a part of the larger Central district, has been a major producer of iron, zinc, and copper in New Mexico for many years. Mine and mill wastes, accumulated during past mining activities in the district, were identified as potential sources of surface and ground-water pollution in the early 1980s. The New Mexico Environmental Improvement Division (NMEID), now the New Mexico Environmental Department, submitted Preliminary Assessment and Site Inspection reports to the U.S. Environmental Protection Agency (EPA) in January and October of 1985. These studies documented evidence for the presence of significant quantities above background levels of lead and copper in tailings from the

TABLE 1—Estimated volume and tonnages of Hanover mill tailings (ACZ Inc., 1993).

	Volume (× 10 <sup>3</sup> m <sup>3</sup> )	Tonnage (× 10 <sup>3</sup> mt)
Pond 1	2,021.1	3,638.0
Pond 2	22.9	41.2
Pond 3	21.3	38.3
Pond 4	23.6	42.5
Pond 5	6.9	12.4
TOTAL	2,095.8	3,772.4

Bull Hill complex, and air release of heavy metals (particularly lead) from the tailings (ACZ Inc., 1993). Subsequently the EPA authorized NMEID to conduct a Site Investigation Follow-up (SIF) study, which was completed and submitted to the EPA in 1988.

Independent of state and federal environmental agencies, MRRC initiated studies to characterize the Hanover mill tailings in terms of heavy-metal mobility, mineralogy, and geochemical and geotechnical properties (Baker, 1993; ACZ Inc., 1993; Walder, 1993, 1994; Walder and Chavez, 1995). Preliminary conclusions of these studies indicated that the rocks surrounding and underlying the tailings are limestones with local igneous intrusions, there is little evidence of weathering and alteration of sulfide minerals in the tailings, and there are sufficiently large quantities of acid-neutralizing minerals present in the tailings. Therefore the tailings are geochemically stable and the risks associated with heavy-metal mobilization in the tailings are very limited. However, eolian and fluvial transport of tailings material may contaminate Hanover Creek and surrounding soils.

Chemical and mineralogical analyses of surface and core samples from pond #1 indicated that zinc concentrations increased with depth, whereas other elements did not show any systematic variation. The mean concentrations of lead, zinc, copper, and cadmium were 951, 9,040, 506, and 29 ppm, respectively (Walder, 1993). These variations in metal concentrations were due to grade and mineralogy of the ores processed rather than mobilization and downward migration of these elements (Walder and Chavez, 1995).

Ponds #2, #3, and #5 are located a few meters from Hanover Creek, and pond #4 is approximately 70 m from the creek. Ore minerals (sphalerite, galena, and chalcopryrite) are more abundant in ponds #2 and #3. These ponds are composed of consolidated, coarse-sand-sized particles. Although the zinc concentrations are also the highest in these ponds (4–6%), only trace amounts of sphalerite were identified during petrographic analysis (Walder, 1994; Walder and Chavez, 1995). The mineral constituents of these ponds are summarized in Table 2.

Acid-neutralizing potential exceeds the acid-producing potential throughout the tailings (Walder and Chavez, 1995) and in the underlying bedrock (Baker, 1993). Acid-neutralizing potential is a measure of the carbonate material available, typically expressed in mt of calcium carbonate (CaCO<sub>3</sub>) per 1,000 mt of rock. Acid-producing

TABLE 2—Mineralogy of tailings from ponds #2, #3, #4, and #5 (summarized from Walder, 1994).

Mineral	Major	Minor	Trace
Andradite	X		
Grossularite		X	
Quartz	X		
Pyroxene	X		
Magnetite	X		
Gypsum	X		
Calcite	X		
Hematite		X	
Pyrite		X	
Sphalerite			X
Galena			X
Chalcopryrite			X

Major phase: Relative intensity of most intense X-ray peak 30;  
 Minor phase: Relative intensity of most intense X-ray peak >7 and <30;  
 Trace phase: Relative intensity of most intense X-ray peak 7.

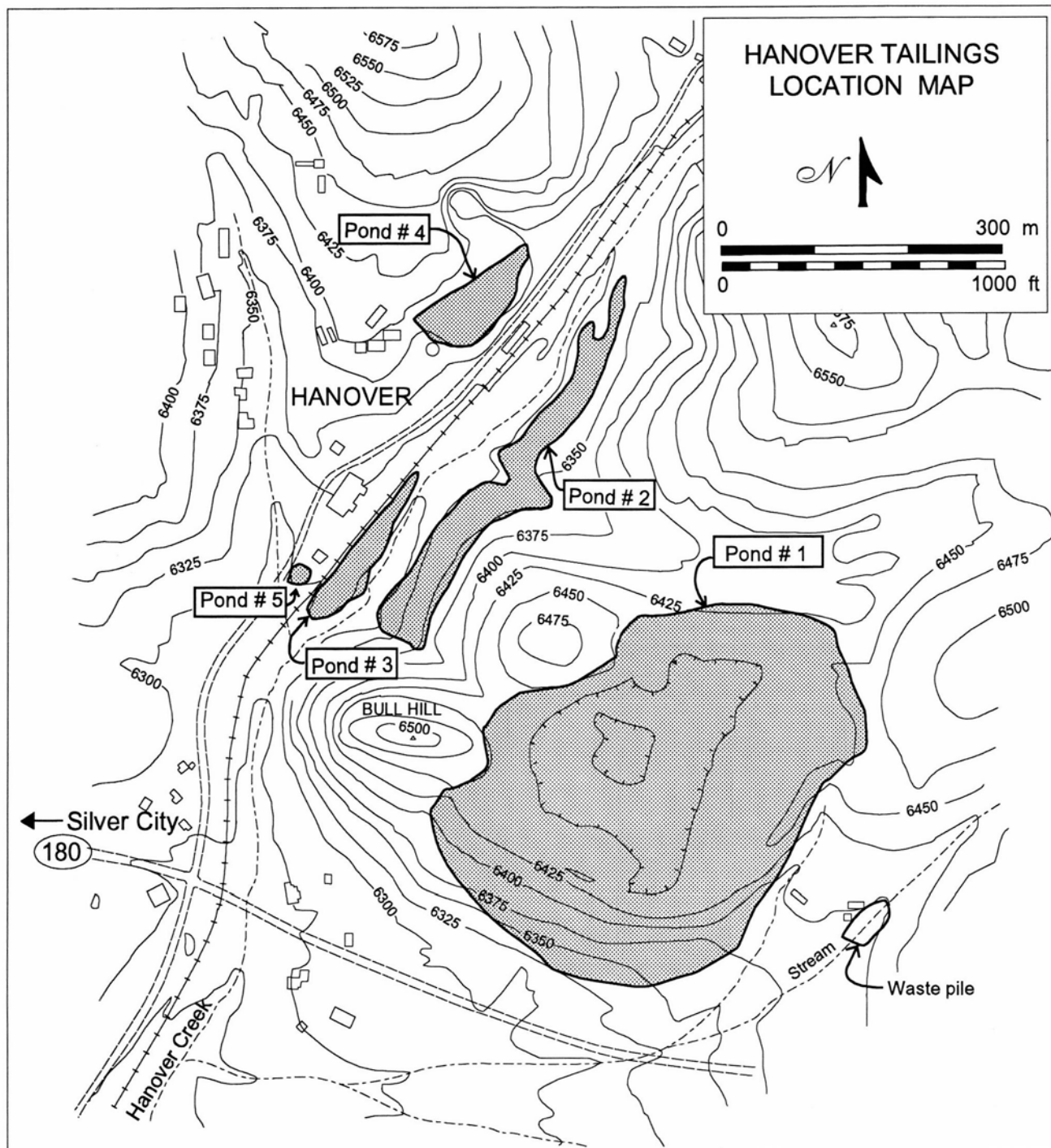

FIGURE 1—Location of Hanover mill tailings (after Walder, 1993). Contour intervals in feet.

potential is generally expressed as the maximum acid generated by oxidation of sulfide minerals, mostly that of pyrite (U.S. Environmental Protection Agency, 1994). Oxidation of sulfide minerals found in the tailings was mainly confined to minor parts of grain margins, indicative of a pre-milling origin, with only traces of post-emplacment oxidation (Walder and Chavez, 1995).

Although Hanover Creek (Fig. 1) is considered ephemeral, it carries significant volumes of runoff during the summer rainy season and during spring snow melt. It passes over a variety of rock types including limestones and felsic intrusions, all of which contribute dissolved substances and provide input into the stream sediments.

Analysis of water samples showed that calcium and sulfate were the major ions present, and their concentrations decreased slightly downstream of the tailings (Baker, 1993). The pH increased slightly downstream (from 7.7 to 7.8), while concentration of total dissolved solids decreased. Zinc concentration increases slightly, from 0.6 to 0.9 ppm, below the tailings. In contrast, copper and lead concentrations in creek water are lower downstream of the tailings, with values of 50 and 2 ppb, respectively (Baker, 1993). However, lead, zinc, and cadmium concentrations in the stream sediments downstream of the tailings ponds (Table 3) were double the background concentrations upstream from the tailings (Walder and Chavez, 1995).



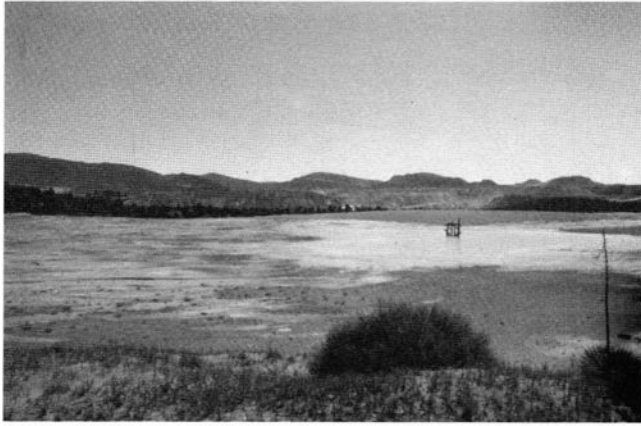

FIGURE 2—View from northwest to southeast across the main pond (#1) of Hanover mill tailings. The Chino mine waste dump is in the background.

Finally, a geotechnical study concluded that, although it may not be completely drained, pond #1 was stable under seismic-loading conditions, and recommended consolidation of the four small ponds on top of this one (ACZ Inc., 1993). The estimated cost of remediation ranged from \$2.3 to \$50.6 million for in-situ remediation (covering the ponds) and off-site storage (i.e. a landfill).

The purpose of the present study was to investigate the feasibility of recovering garnet and sphalerite from the mill tailings as a possible resource to offset remediation costs. Reducing the amount of waste and heavy-metal concentrations in the final waste product to EPA regulatory limits was a secondary objective. Accordingly, lead, zinc, iron, copper, and cadmium were the heavy metals of greatest concern and given special emphasis. The recovery studies were focused on the four small tailings ponds, and the geologic characterization of the tailings was given in relation to the Empire Zinc mine that produced the majority of the tailings material found in the ponds.

### Skarn geology of the Empire Zinc mine

Within the Fierro—Hanover district Cretaceous to Tertiary granitic plutons intrude Paleozoic and Mesozoic sedimentary rocks. Ore deposits are localized in veins, faults, and within massive calc-silicate alteration zones formed in limestones adjacent to intrusive rocks. A detailed discussion of the geology of the district can be found

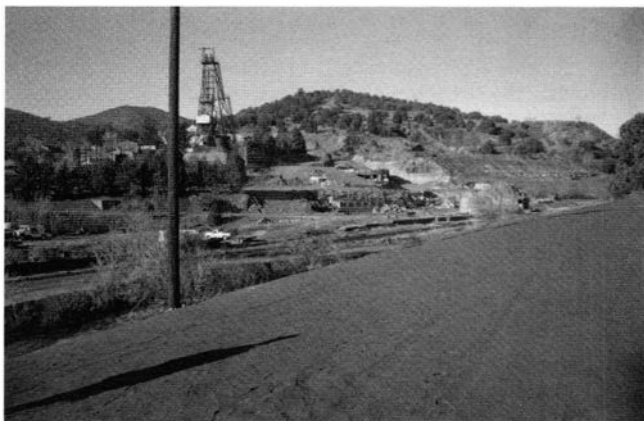

FIGURE 3—Ponds #2 along the east bank of Hanover Creek and #4 adjacent to the head frame of the Empire zinc mine west of the railroad tracks.

TABLE 3—Average metal concentrations in Hanover Creek stream sediments, in parts per million (Walder, 1994).

Metal	Upstream	Adjacent	Downstream
Cadmium	0.9	1.7	4.6
Copper	641.0	548.0	693.0
Lead	20.6	42.1	80.0
Zinc	417.0	761.0	2,120.0

in Jones et al. (1967), and salient features of skarn mineralization in southern New Mexico is presented by Lueth (this volume).

The Empire Zinc mine and quarries worked the zinc skarns around the southern, equigranular lobe of the Hanover—Fierro pluton (Figs. 4, 5a). The overall mineralization patterns in the zinc-skarn deposits are strongly controlled by original stratigraphy and secondary structural controls (Turner, 1990; Turner and Bowman, 1993). Mineralization typically occurred in the 35 m thick Tierra Blanca Member of the Lake Valley Limestone (Mississippian) and, to a lesser extent, in the 30 m thick Middle Blue Limestone Member of the Oswaldo Formation (Pennsylvanian). The distribution of ore and calc-

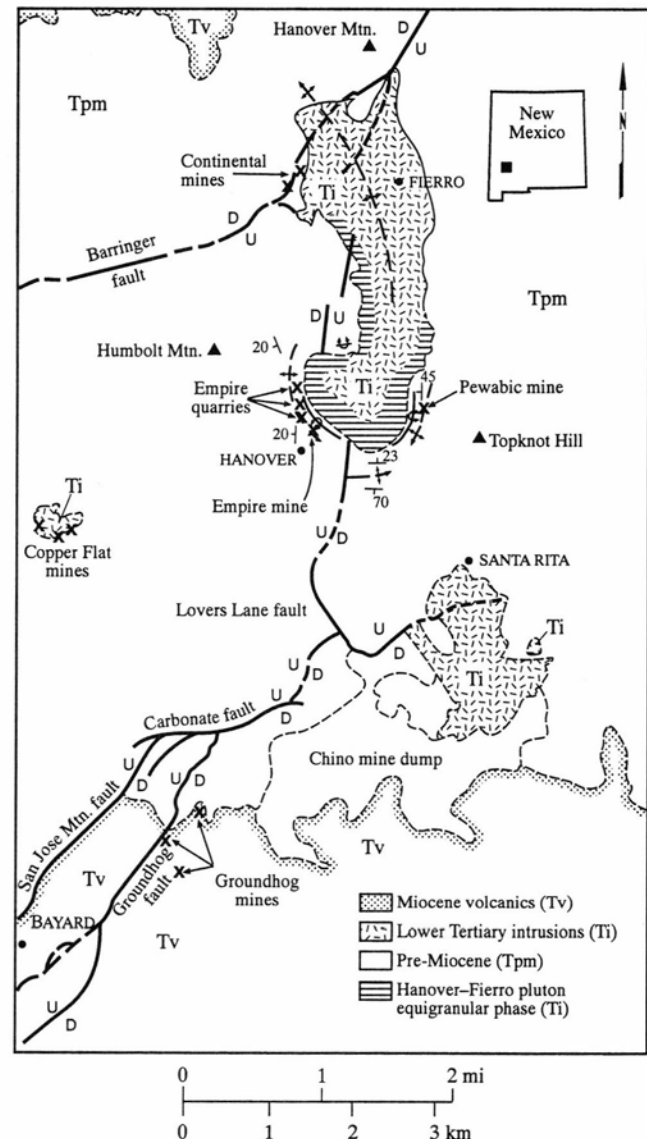

FIGURE 4—Regional geology and location of the Central Mining district, Grant County, New Mexico (from Turner, 1990).



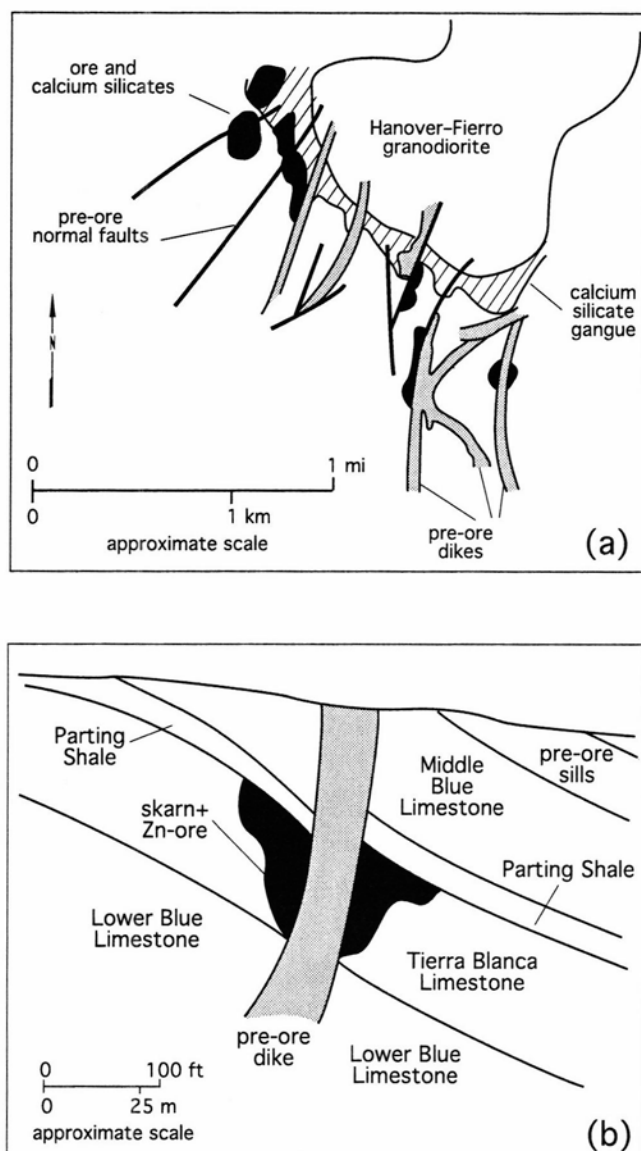

FIGURE 5—A, Generalized map of skarn and Zn-ore distribution around the southern edge of the Hanover-Fierro pluton; B, generalized cross section of skarn distribution in members of the Lake Valley Limestone (Mississippian) and Oswaldo Formations (Pennsylvanian) adjacent to a near-vertical pre-ore dike (after Turner, 1990).

silicate minerals was strongly influenced by the thin (10 m thick) Parting Shale Member at the base of the Oswaldo Formation (Fig. 5b). Pre-ore dikes also appear to have a strong influence on ore distribution in the district (Jones et al., 1967), especially in the zinc-skarn deposits. These dikes are strongly altered along with the limestones in the deposits. The sphalerite orebodies tend to be vari-

ably podiform to tabular within the calc-silicate zones.

Three distinct skarn mineralogies were delineated in recent work by Turner (1990): (1) garnet-rich skarn with minor pyroxene, (2) pyroxene-rich skarn with minor garnet, and (3) garnet+pyroxene-banded skarn. The garnet-rich skarn is closest to the Hanover-Fierro pluton and contains only minor late-stage pyrite and sphalerite. Sphalerite ore is confined mainly to the pyroxene-rich and garnet+pyroxene-skarn zones farther from the pluton, yet adjacent to pre-ore dikes. Most of the mine workings do not penetrate large areas of garnet rock. In addition, many sphalerite orebodies were mined adjacent to garnet-rich horizons which were bypassed and often formed the roof of the orebody.

Mineral paragenesis studies at the Empire Zinc mine by Turner (1990) showed that the skarn formed in three stages. Stage one is characterized by garnet, pyroxene, and magnetite. Garnets tend to be euhedral to anhedral and are often compositionally and texturally zoned. Garnet and pyroxene compositions determined by electron microprobe show the garnet to be predominantly andradite (Ad<sub>58-100</sub>, Gr<sub>0-35</sub>, Sp<sub>0-10</sub>—reported as mol % end-member components: andradite, grossular, and spessartine) and the pyroxene to be hedenbergite (Hd<sub>19-71</sub>, Joh<sub>5-74</sub>, Di<sub>4-67</sub>—mol % end-member components: hedenbergite, johannsonite, diopside) (Turner, 1990). Stage two was the main period of sulfide-ore deposition (sphalerite with subordinate pyrite, chalcopyrite, and galena). Stage-three mineralization involved the filling of veins with calcite, quartz, hematite, sulfides, magnetite, and minor alteration of previously formed calc-silicate mineral phases.

#### Garnet production, uses, and specifications

Garnet is the general name for a group of complex silicate minerals that have a number of industrial uses. The chemical composition of the mineral group can be represented by the general formula  $X_3Y_2(SiO_4)_3$ , where X is a divalent cation (such as calcium, magnesium, iron, and manganese) and Y is a trivalent cation (such as aluminum, iron, and chromium). The most common garnet minerals and their physical properties are presented in Table 4.

Garnets are found in a variety of geologic environments, but are most common in metamorphic rocks such as medium- to high-grade phyllites, schists, gneisses, and impure marbles, as well as in contact-metamorphic halos of carbonate-bearing rocks around intrusives. They also occur in igneous intrusive and extrusive rocks. Garnets are also found as a common detrital mineral in trace quantities in clastic sedimentary rocks. Almandine ( $Fe_3Al_2(SiO_4)_3$ ), the most commonly used species, is found in pelitic schists, gneisses, and granitic intrusive rocks. The largest production of industrial garnet comes from alluvial deposits of almandine garnet. Grossular ( $Ca_3Al_2(SiO_4)_3$ ) and andradite ( $Ca_3Fe_2(SiO_4)_3$ ) garnets are

TABLE 4—Common garnet minerals and their physical properties (O'Driscoll, 1993).

Mineral	Formula	Hardness	Spec. grav.	Color
<i>Pyrospite Series</i>				
Pyrope	$Mg_3Al_2Si_3O_{12}$	6.5–7.5	3.5–3.8	Deep crimson
Almandine	$Fe_3Al_2Si_3O_{12}$	7.5	3.9–4.2	Dark red/brown
Spessartine	$Mn_3Al_2Si_3O_{12}$	7.0–7.5	4.1–4.3	Brownish red
<i>Ugrandite Series</i>				
Uvarovite	$Ca_3Cr_2Si_3O_{12}$	7.5	3.4–3.5	Emerald green
Grossular	$Ca_3Al_2Si_3O_{12}$	7.0	3.5–3.7	Pale green
Andradite	$Ca_3Fe_2Si_3O_{12}$	6.5–7.0	3.7–3.8	Dark brown–green

formed during regional or contact metamorphism of carbonate-bearing rocks; they are also used for certain industrial applications. The other major garnet species, spessartine ( $\text{Mn}_3\text{Al}_2(\text{SiO}_4)_3$ ), is most commonly found in rhyolites and granite pegmatites. Spessartine garnet is rarely used for industrial applications because of its dispersed nature in rocks and low volume of material.

Garnet production in the United States has increased from 30,000 to 47,000 mt during the last decade (Austin, 1994). The main reasons for this growth are that garnet minerals are considered chemically inert and environmentally safe, have a widespread distribution, and occur in large, relatively pure deposits. It is estimated that garnet consumption will increase to 72,000 mt by 1999 (Anonymous, 1995). In 1994 garnet production in the United States was approximately 51,000 mt of which 40,600 mt was used or sold by producers (U.S. Bureau of Mines, 1995). The United States also imported 5,400 mt and exported 9,000 mt of garnet in 1994 (Anonymous, 1995). Current garnet production in the United States comes from five mines in two states. Emerald Creek Garnet of Fernwood, Idaho, produces almandine from a large placer deposit and is the largest domestic producer of garnet. Their production was approximately 26,000 mt in 1993. Barton Mines Corporation in North Creek, New York, produces almandine, pyrope, and grossular from the Gore Mountain deposit. Barton Mines is considered the largest garnet producer in the world when coupled with its Australian subsidiary. NYCO Minerals Incorporated of Willsboro, New York, is the oldest and largest wollastonite producer in the world, and produces 10,000-12,000 metric ton per annum (mtpa) of grossular garnet as a byproduct. The NYCO product is processed by International Garnet Inc., Keeseville, New York.

The increased demand for garnet has prompted other companies to expand production or increase exploration efforts. Patterson Minerals Corporation of Wingdale, New York, is a new entrant to the garnet market (North American Minerals News, 1995). The company initiated almandine-garnet production in mid-1994. In addition, a number of exploration programs are underway in North America. Polestar Exploration Inc. discovered a high-grade garnet-skarn deposit at Mt. Riordan, British Columbia, Canada (Mathieu et al., 1992). Reserves of andradite and grossular garnet at this deposit are estimated at 40 million mt. Royalstar Resources Ltd. began limited production of skarn garnet at the San Pedro mine, Santa Fe County, New Mexico (Fattah, 1994). Proven reserves have been reported as 7-8 million mt grading 85% andradite garnet. Cominco Resources International Ltd., British Columbia, Canada, has completed feasibility studies on the Altar garnet deposit in Montana. The Altar deposit consists of placer-gold tailings and contains up to 4% almandine garnet (Anonymous, 1994a). Two garnet deposits in Arizona were explored by Bitterroot Resources Ltd., British Columbia, Canada (Anonymous, 1994b). These deposits include the Williams high-grade almandine deposit and a property sub-leased from Santa Fe Pacific Gold Corporation.

Factors influencing garnet consumption and market prospects include the product quality, market demand, and freight costs to market destinations (O'Driscoll, 1993). Physical characteristics rather than chemical composition and purity often are the factors in determining the quality of garnet. The most important requirement is the supply of clean garnet, free of heavy metals and radioactive

minerals, with an optimum grain-size distribution. The product should also conform to existing market specifications and be priced competitively with readily available alternative materials such as fused alumina, olivine, silicon carbide, copper slags, and other metallic abrasives.

Concentration of garnets can be accomplished by a number of separation techniques. A typical process would involve crushing, grinding, sizing, and various separation technologies. Gravity separation by shaking tables, spirals, jigs, and Reichert cones is effective, particularly for initial separation steps. Magnetic and electrostatic separators, especially the new-generation of high-intensity (rare-earth element) permanent magnets, can be used to remove impurities or separate garnet from magnetically less-susceptible minerals. Flotation of garnets can be accomplished with sulfonate-type collectors in 2-3 pH range (American Cyanamid Company, 1989).

The angularity, hardness, high specific gravity, and inert nature of garnet minerals make them useful in a number of industrial applications. Major end-uses (and the percentage of garnet consumption in the United States) include sand-blasting and water-jet cutting (60%), water filtration (20%), coated abrasives (10%), and polishing (10%) (O'Driscoll, 1993). Garnet use in sand-blasting is increasing due to a shift from silica sand and smelter slags to those materials that do not contain free silica or heavy metals. This is because of occupational safety and health concerns, specifically the incidence of silicosis. In addition, garnet-abrasive materials can be reused and tend to maintain grain angularity even after repeated use.

The value of garnet varies widely from as low as \$60/ton for low-quality sandblasting material to as much as \$2,000/mt for high-quality, micronized, polishing-grade material (Austin, 1994). Royalstar Resources estimated the selling price of San Pedro mine andradite garnet at \$33/mt and production costs at \$13/mt (Anonymous, 1993). The selling price of garnet in North America in 1993 was in the range of \$150-300/mt (O'Driscoll, 1993).

The material requirements for abrasive-cleaning and water-jet cutting applications depend on the substrate, machine, environment, and operator skills. Stainless-steel blasting may require coarse sizes (1.5 mm), while finer sizes are required for paint removal (O'Driscoll, 1993). The most important requirement in blasting is the ability of the abrasive material to maintain a uniform surface profile. However, there appears to be no definitive method available for testing the quality of garnet or other abrasive material except for actual application.

The California Air Resources Board (ARB) requires all loose-grain abrasives used in the state to be certified at the ARB testing facility (Austin, 1994). The testing is conducted according to "Methods of test of abrasive media evaluation" and focuses on the environmental impact of sand-blasting abrasives rather than on their qualities or performance (California Air Resources Board, 1975, Test Method No. CA 371-A). The test requires 18.75 kg samples of each size fraction to be shot at feed rates within the range of 200-340 kg/h (450-750 lbs/h).

The Steel Structures Painting Council (SSPC) specification SSPC-AB1 (Steel Structures Painting Council, 1991) defines the requirements for selecting and evaluating slag and mineral abrasives used in blast-cleaning steel and other surfaces for painting. The SSPC can carry out comparative testing of garnet and other loose-grain abrasives to determine their quality and suitability to meet military specifications. Commercial testing firms, such as

KTA-Tator Inc., Pittsburgh, Pennsylvania, can also evaluate the quality of garnet and other abrasives in accordance with SSPC specifications (D. Weldon, pers. comm. 1995). The SSPC test to determine the surface cleaning rates by abrasives recommends the use of 227 kg (500 lbs) of material in each size range (Steel Structures Painting Council, 1991).

The International Organization for Standardization (ISO) has developed specifications for preparation of steel substrates before application of paints and related products (International Organization for Standardization, 1992). The organization is also preparing specifications for non-metallic blast-cleaning abrasives that includes garnet (International Organization for Standardization, in preparation). According to the proposed specifications for abrasives, specific gravity should be 3.5-4.2 kg/dm<sup>3</sup> hardness greater than 6.5 on the Mohs scale, moisture content less than 0.5%, and water-soluble chlorides less than 0.01%. The most widely used particle sizes in the U.S. market for blast-cleaning applications range from 0.2 to 1.0 mm, 0.2 to 0.6 mm, and 0.1 to 0.3 mm (Austin, 1994).

In abrasive-jet cutting, garnet grains are entrained in a stream of high-velocity water impinging on material to be cut at very high pressures. Water-jet cutting is most commonly used when fire hazards are present, e.g. oil refineries. It is also very useful in cutting underwater steel structures and for shape-cut material such as marble and granite, automotive glass, textiles, plastics, aluminum, and high-strength steels.

Water-jet requires very hard garnets such as almandine, with sharp, angular cutting edges. However, for ductile materials softer and less expensive abrasives such as slags may outperform garnet (O'Driscoll, 1993). Garnet in coarse sizes (up to 1 mm) is favored for steel cutting; for most other cutting applications, 0.25-0.18 mm (60-80 mesh) is the most popular grade and accounts for 90% of garnet used for this purpose (Austin, 1994). Equipment manufacturers generally recommend the desired size ranges for a particular application (e.g. Jet-Edge Inc., Minneapolis, Minnesota), and can run comparative tests on garnets to evaluate the cutting rates (D. LaFavor, pers. comm. 1995).

An expanding application of garnet material is in bedded water-filtration technology. Sand filters are generally used by public waterworks around the world to purify drinking-water supplies. Inherently slow sand filters are still in use in several major cities in Europe. More efficient multi-layer (coarse anthracite and sand) filters were developed in the United States about 40 years ago. The multi-layer concept has been recently extended to three-layer designs consisting of coarse garnet or ilmenite, sand, and coarse anthracite (Ives, 1993). The American Water Works Association (1989) has set standards for filtration materials (sand and anthracite) that are not very prescriptive. The association is reportedly preparing a revision of these standards that will also include garnet-filtration media. Ives (1990) provided a series of procedures for testing filtration media that defines effective size (sieve size at which 10% by weight is finer), uniformity coefficient (the ratio of size at which 60% by weight is finer), specific gravity (1.4-3.9 g/cm<sup>3</sup>), settling velocity (in water at 20°C), hardness (greater than 2 on the Mohs scale), sphericity (0.65-0.85), acid-solubility (less than 5%), and resistance to attrition (weight loss by attrition less than 5%). The most common size ranges of garnet for water-filtration applications in the United States are

—4.75 +1.41 mm, and —0.84 +0.3 mm or —0.71 +0.25 mm (Austin, 1994). The finer-sized garnets are generally used in pressure-filtration systems.

#### Experimental methods

The samples used in this study were collected from the same sampling sites as those used in earlier studies (Walder, 1994; Walder and Chavez, 1995). Sample holes were dug approximately 1 m deep and samples were taken from the bottom and along a wall profile of each hole. Sample material was dried under heat lamps, weighed, split, and mixed in proportion to the tonnages of the tailings ponds in order to obtain a composite sample of ponds #2, #3, #4, and #5. The samples from the individual ponds and the split samples of the composite were used to determine metal concentrations and size distributions and for grinding, flotation, and gravity-separation tests.

Tyler standard series 20 through 400 mesh were used for screen analyses. Thin sections were made from each screen fraction to determine the mineral content and relative proportions of minerals by point-count method. Splits of the various fractions of the sample material were prepared for flame-atomic-absorption spectroscopy (FAAS) by aqua-regia digestion and were analyzed for lead, zinc, copper, cadmium, and iron concentrations (Brandvold, 1974). Where applicable, quality-assurance procedures established at the Analytical Laboratories of the New Mexico Bureau of Mines and Mineral Resources were followed throughout this study.

Flotation experiments were conducted with 1 kg splits of the composite sample. For each experiment the sample was mixed with tap water and agitated in a flotation cell for 4 minutes. The pulp was then allowed to settle for 2 minutes and decanted to remove the slime fraction. The slime fraction was discarded from the process because it has detrimental effects on the oxide flotation stage. Slimes also increase the viscosity of the slurry and decrease the sharpness of gravity separation. The coarse fraction was transferred to a laboratory rod-mill and ground for a pre-determined length of time. Further grinding was necessary to achieve particle liberation, to prepare a uniformly sized material for gravity separation, and to create fresh surfaces on sulfide minerals for flotation. The desired particle-size distribution for flotation is 80-90% passing 65 mesh (212 µm).

Sulfide flotation tests were performed with rod-mill-ground material in 2 liter cells with a Denver 12 D laboratory flotation machine at approximately 30% pulp density. Bulk-sulfide flotation was carried out at natural pH (7.3) using conventional flotation chemicals (American Cyanamid Company, 1989). For selective flotation of pyrite and sphalerite, copper sulfate was used as an activator for sphalerite, while pyrite was depressed using sodium sulfite in high-alkaline media where pH was adjusted with lime to 11.5. The bulk-sulfide flotation concentrate also contained considerable amounts of slime. Therefore, sodium silicate was used to depress the slimes and clean the sphalerite concentrate. Concentrates and tailings were collected and analyzed by FAAS after aquaregia digestion to determine the metal contents and recoveries. Sulfide flotation tailings were again deslimed twice by decantation before the oxide-flotation tests. Oxide flotation involved an initial sulfidization followed by an amine flotation (Cetin, 1995). The concentrate from the oxide flotation was discarded from the process and com-

bind with the slime fraction. The combined flotation tailings were then subjected to gravity concentration. A shaking table was used to separate the garnet and other heavy minerals from the light-mineral fraction. This circuit involved two rougher stages and a single cleaner stage. Five products were obtained from each stage: concentrates 1 and 2, middlings, tailings, and slimes. After gravity separation a garnet concentrate, a coarse-tailings fraction (low in heavy-metal contaminants), and a slimes/fine tailings fraction (final tailings) were obtained.

A phosphate-treatment technique was also applied on the final tailings to reduce the mobility and bioavailability of the heavy metals (especially cadmium and lead) and the potential for acid generation in the final tailings. Treatment of contaminated soils with a phosphate compound (e.g. apatite) is a fairly new technique suggested for lead abatement (Ruby et al., 1994a). After treatment, complex lead—phosphate compounds (i.e. hydroxypyromorphite,  $Pb_5(PO_4)_3OH$ ) form that have very low solubilities in aqueous solutions. In addition to lead, other heavy-metal (i.e. cadmium) phosphate compounds may also form (Faure, 1991). Phosphate may also cover pyrite surfaces and prevent oxidation, thus reducing the potential for acid generation in the final tailings. After 24 hour bottle-roll phosphate-treatment tests the slurries were filtered and the Environmental Protection Agency Toxicity Characteristic Leaching Procedure (TCLP) test (Federal Register, 1990a) was performed on the untreated and phosphate-treated solids.

### Results and discussions

Screen analysis of the composite tailings sample showed that almost 27 wt.% of the material was finer than 37  $\mu m$  (400 mesh). This fraction contained approximately 50 wt.% of cadmium, copper, lead, and zinc and 25 wt.% of the iron in the composite tailings. Oxidized copper, lead, zinc, and cadmium minerals are friable, hence they tend to concentrate in the slimes fraction. Table 5 gives screen and chemical analysis, and Table 6 shows the garnet content of the composite tailings sample. Petrographic examination of each size fraction indicated a recoverable garnet content of 28.3 wt.%. Figure 6 shows a thin section of —28 +35 mesh composite tailings material. The minerals in this photomicrograph are mostly garnets with some small sulfide and oxide minerals cemented together by gypsum, which indicated that further grinding was required. After 5 minutes of grinding in a rod-mill the material was reduced to

TABLE 6—Size distribution and garnet content of the composite tailings sample.

Mesh	Size ( $\mu m$ )	wt. %	vol. % garnet	wt. % garnet
+10	+2000	2.5	N/D <sup>1</sup>	N/D
+20	+850	9.4	31.6	34.8
+28	+600	7.3	21.1	23.1
+35	+425	6.8	27.1	29.2
+48	+300	7.2	32.4	34.7
+65	+212	7.8	26.7	26.4
+100	+150	10.0	27.2	27.4
+150	+105	8.0	28.2	28.9
+200	+74	3.6	35.2	35.5
+270	+53	5.5	21.2	20.3
+400	+37	5.1	20.0 <sup>2</sup>	20.0
-400	-37	26.8	N/D	N/D

<sup>1</sup>Not determined; <sup>2</sup>Estimated

the desired size for flotation, and grain liberation was achieved for effective gravity separation. Figure 7 illustrates the logarithmic size-distribution plots of the composite tailings before and after grinding.

Sulfide minerals were first floated in the bulk-flotation stage using various reagent combinations. Concentrates from the bulk-flotation tests were combined and, after regrinding for 4.5 minutes in the rod-mill, sphalerite/pyrite selective flotation was performed to make a saleable-grade product. The sphalerite concentrate was ob-

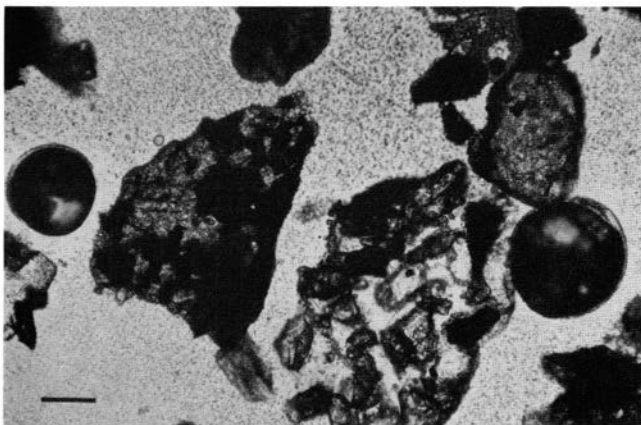

FIGURE 6—A photomicrograph of —28 +35 mesh (—600 +425  $\mu m$ ) composite sample. Note the gypsum-cemented multilithic fragment at the lower right-hand side of the photo. Scale bar represents 0.1 mm.

TABLE 5—Screen analysis and distribution of metals in various size fractions of the Hanover tallings composite sample (ponds #2-5).

Screen analysis			Chemical analyses									
Mesh	Size ( $\mu m$ )	wt. %	Cd		Cu		Pb		Zn		Fe	
			ppm	% distr.	ppm	% distr.	ppm	% distr.	wt. %	% distr.	wt. %	% distr.
+20	+850	11.9	79	9.41	553	9.56	1,119	11.02	3.45	9.47	9.27	13.66
+28	+600	7.3	71	5.18	432	4.58	709	4.28	2.99	5.03	8.56	7.73
+35	+425	6.8	67	4.57	405	4.01	745	4.21	2.68	4.22	8.17	6.90
+48	+300	7.2	64	4.57	421	4.37	787	4.65	2.53	4.17	8.15	7.21
+65	+212	7.8	64	4.98	448	5.06	898	5.78	2.58	4.63	9.11	8.77
+100	+150	10.0	69	6.92	382	5.56	769	6.38	2.77	6.40	6.77	8.40
+150	+105	8.0	68	5.43	360	4.17	835	5.52	2.78	5.12	7.28	7.20
+200	+74	3.6	63	2.23	348	1.79	751	2.20	2.61	2.14	9.10	4.00
+270	+53	5.5	78	4.32	469	3.77	918	4.20	3.12	3.98	8.29	5.68
+400	+37	5.1	75	3.81	535	3.94	876	3.68	3.14	3.68	8.38	5.27
-400	-37	26.8	181	48.58	1,366	53.19	2,167	48.08	8.27	51.16	7.58	25.18
Assay head			100		689		1,210		4.34		8.08	
Calculated head			104	100.00	553	100.00	1,179	100.00	4.19	100.00	7.96	100.00
Flotation feed <sup>1</sup>	(73.2)		76	(51.42)	255	(46.81)	817	(51.92)	2.69	(48.84)	8.10	(74.82)

<sup>1</sup>Estimated flotation feed (+400 mesh material)

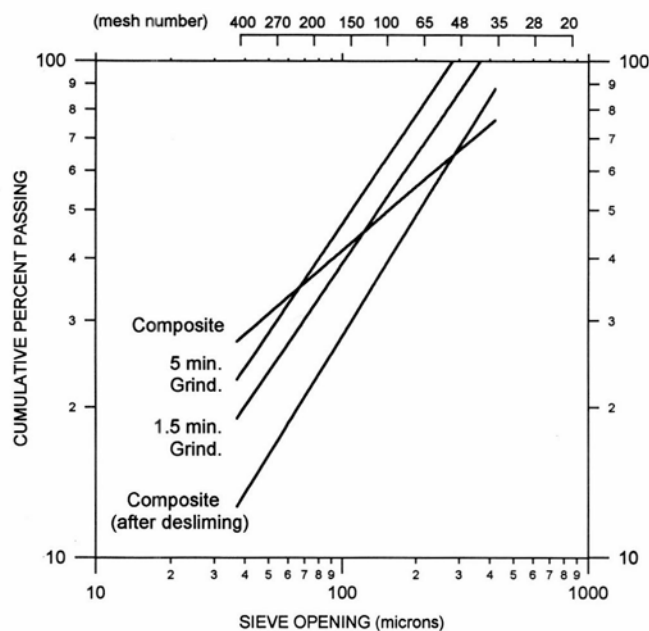

FIGURE 7—Hanover mill-tailings composite sample grinding-test results.

tained after one rougher and two cleaning flotation stages. The overall zinc recovery in the concentrate was 26.9% that assayed 50.9% zinc. Optical-microscopy analyses of the concentrate also indicated that most of the sphalerite and pyrite grains were liberated and were free of chalcopyrite inclusions. Galena and chalcopyrite were also present in trace quantities (Cetin, 1995). The concentrate might be further upgraded by additional cleaning stages, but this would also reduce the overall zinc recovery. Tailings of the selective flotation were discarded into the slimes fraction for disposal.

Oxidized lead, zinc, and copper minerals were further removed from the gravity circuit feed in the oxide-flotation stage. Since oxide flotation is more sensitive to slimes, the sulfide-flotation tailings had to be deslimed twice by decantation. The concentrates of the oxide-flotation stage generally assayed less than 4% zinc, hence they were discarded into the slimes fraction while the tailings were subjected to gravity separation.

As a result of the previous treatment stages described above, feed to the gravity-separation circuit was only 50.8 wt.% of the original material. Slimes and fine-tailings of the first and second rougher stages were combined for disposal. Concentrate 1 contained the heaviest and the coarsest minerals, such as magnetite, hematite, pyrite, and some coarse garnet particles. Concentrate 2 contained predominantly garnet with minor quantities of heavy minerals such as sphalerite, small-sized pyrite, and magnetite inclusions in silicates and lighter minerals such as pyroxene. This fraction was recovered as the garnet concentrate and comprised 20.3 wt.% of the original feed. Overall recovery of garnet minerals in the concentrate was calculated as 43.8%.

The heavy-mineral concentrates (#1) from both the roughing and cleaning stages were combined with the coarse tailings and discarded from the process. The coarse-tailings fraction contained less than 500 ppm lead and 40 ppm cadmium (Table 7), which are concentration levels recommended by the EPA for remedial action in residential areas (Federal Register, 1990b). If classified as

TABLE 7—Chemical analyses of the feed and products of the re-processed tailings.

	wt. %	Cd (ppm)	Cu (ppm)	Pb (ppm)	Zn (%)	Fe (%)
Feed	100.0	104	553	1,179	4.19	7.96
Sphalerite concentrate	1.9	1,145	6,225	10,100	50.90	6.27
Garnet concentrate	20.3	28	197	394	1.19	6.11
Coarse tailings	26.8	33	225	445	1.31	8.12
Final tailings <sup>1</sup>	51.0	133	656	1,544	5.16	8.68

<sup>1</sup>Calculated; (10,000 ppm = 1%)

hazardous waste, the final process tailings would require further treatment before disposal.

Based on the results of separation tests, a flowsheet for garnet and sphalerite recovery was designed. The flow diagram in Figure 8 also includes the percent weight distribution of each stream. The total amounts of garnet and sphalerite that can be recovered from the tailings by this processing scheme are estimated as 27,000 and 2,500 mt, respectively.

#### Characterization of the garnet concentrate

Hanover mill tailings have been produced from the pyroxene-rich and garnet+pyroxene-banded skarns because of the high-sphalerite content of these rocks. Therefore, pyroxene content of the tailings is fairly high. The specific gravity of pyroxene (3.2-3.3 kg/dm<sup>3</sup>) is close to that of garnet (3.7-3.8 kg/dm<sup>3</sup>), and most of the coarse pyroxene is concentrated along with garnet during gravity separation diluting the garnet concentrate. Petrographic analysis demonstrated that the garnet concentrate contained 61 wt.% garnet, 21 wt.% pyroxene, and 18 wt.% other minerals. X-ray diffraction analysis confirmed that andradite and hedenbergite were the major garnet and pyroxene minerals, respectively. Figure 9 illustrates a typical example of the concentrate.

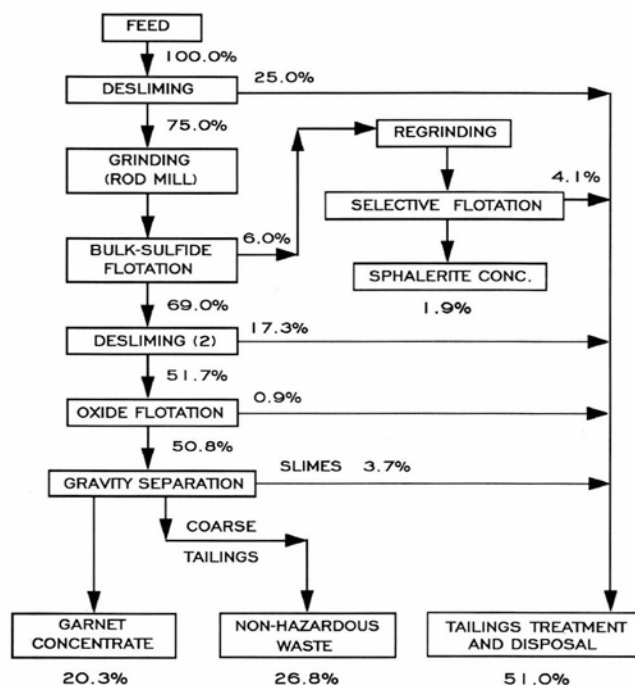

FIGURE 8—Flowsheet for recovery of garnet and sphalerite from Hanover mill tailings.

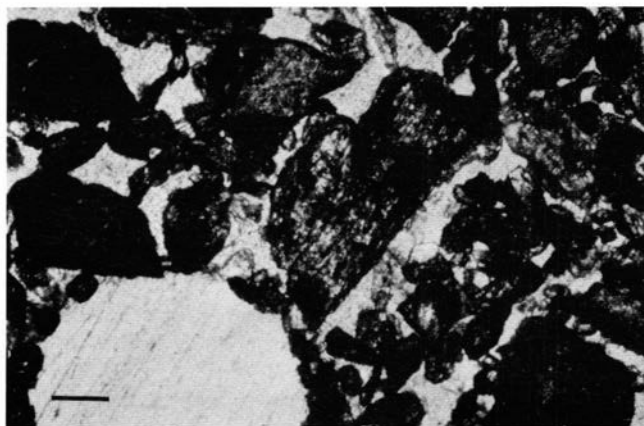

FIGURE 9—A photomicrograph of the garnet concentrate. A pyroxene grain is in the center of the view. Scale bar represents 0.1 mm.

As discussed previously, the most desirable and marketable sizes of garnet minerals for blast-cleaning applications are usually the coarser sizes (larger than 0.5 mm). Therefore, excessive crushing and grinding of garnet minerals adversely affect the marketability of the product. In this study, however, a rod-mill grinding stage was required to break apart the cemented particles and create fresh surfaces for flotation. Thus the garnet concentrate recovered was almost 40% finer than the 200 mesh size (Table 8). The market share for this size of garnet is very small and is dominated by almandine garnet (because of its greater hardness compared to andradite) for water-jet cutting and polishing applications.

The garnet concentrate is also unsuited for water-filtration applications. Much of the garnet product recovered was less than the preferred grain size used for water-filtration systems. The specific gravity of the concentrate, also an important parameter in bedded water-filter applications, was  $3.57 \pm 0.03 \text{ kg/dm}^3$ . Although there are no standards for the use of garnet in water filtration, the specific gravities greater than  $3.8\text{--}3.9 \text{ kg/dm}^3$  are preferred in modern systems. In addition, acid-soluble-matter content of the garnet concentrate (6.7%) was also higher than the recommended criteria (5.0%) for water-filtration media (American Water Works Association, 1989). Therefore, small grain size, low specific gravity, and high acidsoluble-matter content of the concentrate render this product unsatisfactory for water-filtration media.

Base-metal contaminants in the garnet product also limits its uses and marketability for abrasive or filtration. These metals are generally concentrated with the garnet during gravity separation, resulting in contamination and dilution of the product. The garnet concentrate contains 6.1% acid-soluble iron (Table 7), which is derived mostly from pyrite and magnetite. The presence of pyrite adversely affects the marketability of the product for water filtration or water-jet-cutting applications.

TABLE 8—Size distribution of the garnet concentrate.

Mesh	Size ( $\mu\text{m}$ )	wt. %
+65	+212	14.9
-65 +100	-212 +150	14.6
-100 +150	-150 +105	14.0
-150 +200	-105 +74	17.7
-200	-74	38.8

In addition, the concentrate contains approximately 1.2% zinc and 400 ppm lead. The quality and purity of the garnet concentrate can be improved by more efficient desliming, optimization of flotation parameters, closely sizing the gravity-circuit feed, and further cleaning the dried concentrate by magnetic and electrostatic separation methods. However, additional work is not justified considering the original grain size and mineralogical composition of the tailings.

### Tailings treatment and disposal

The final tailings fraction contained high levels of cadmium, lead, and zinc (Table 7), predominantly as oxide minerals with lesser amounts of sulfides. This fraction can be considered hazardous waste, and it would require further treatment to immobilize these metals for disposal as non-hazardous waste. To this end, a novel phosphate-treatment process was briefly investigated (Ruby et al., 1994a, b). Preliminary experiments were conducted with calcium-phosphate solutions in the ratio of 1, 5, and 10 wt.%  $\text{Ca}(\text{H}_2\text{PO}_4)_2$  to the weight of solids to be treated, at 25-30% pulp densities. The final tailings fraction passed the TCLP test for lead but failed for cadmium prior to phosphate treatment (Table 9), whereas the tailings passed the test for both lead and cadmium after treatment with 5% phosphate. During phosphate treatment the pH of the solution was adjusted with lime to 8.5-9.0 in order to prevent leaching of lead and cadmium. These metals have not been detected in the phosphate solutions when solids were separated by filtration.

### Conclusions

The sphalerite concentrate could be salable depending on the demand for concentrates at North American smelters. In contrast, the marketability of the poor-quality andradite product during the short-term remediation is not likely, because of the abundance of higher-quality almandine and grossular garnets already on the market. On the other hand, garnet-rich skarn with little or no associated sulfide minerals remains in place at the Empire Zinc mine that could be mined and processed for its garnet content, particularly for blast-cleaning applications in coarser-size fractions.

If the tailings were classified as hazardous waste, the amount of material to be treated could be reduced by about one-half by flotation and gravity separation processes. The final tailings could be rendered non-hazardous by applying a phosphate-amendment technique. The phosphate-treatment tests are preliminary, and further studies are necessary to investigate the process parameters such as pulp density, pH, phosphate to heavy-metal ratio, and long-term stability of the phosphate complex compounds.

During the course of this study it became apparent that

TABLE 9—TCLP results on the tailings fraction before and after phosphate treatment.

	TCLP extractions (ppm)		Phosphate solutions (ppm)		
	Cd	Pb	Cd	Pb	Final pH
Before treatment	1.83	0.69	N/A	N/A	N/A
1%	1.77	<0.50	<0.05	<0.10	8.52
5%	0.56	<0.50	<0.05	<0.10	8.54
10%	0.20	<0.50	<0.05	<0.10	7.82

TCLP limits for hazardous waste classification are 1.0 ppm for cadmium and 5.0 ppm for lead.



the recovery of garnet would not be feasible, hence MRRC started moving the tailings onto the main pond in late 1994. When all of the smaller ponds are moved, the large tailings pond will be recontoured, stabilized, capped, and revegetated.

### Acknowledgments

The authors would like to thank Michael Baum and Don Lillie of MRRC for providing core samples, unlimited access to the site, reports, and other proprietary information. We also gratefully acknowledge their close collaboration during the course of the project. David R. Turner graciously granted us permission to use his analytical data and geologic maps of the Empire Zinc mine. Robert Eveleth provided historical information on the mine and reviewed the manuscript. Virginia T. McLemore reviewed the manuscript and provided valuable comments and suggestions for improvement. In addition, the authors wish to thank Lynn A. Brandvold, Sandra J. Swartz, and Barbara R. Popp for their assistance with chemical analyses, and to Chris McKee for the X-ray diffraction analysis.

A graduate assistantship from the New Mexico Bureau of Mines and Mineral Resources (Dr. Charles E. Chapin, Director) and partial funding from the Minerals and Engineering Department of the New Mexico Institute of Mining and Technology and MRRC for one of the authors (U.C.) are also gratefully acknowledged.

### References

- ACZ Inc., 1993, Feasibility and conceptual design for remediation of the Hanover property, Silver City, New Mexico: ACZ Inc., Engineering and Environmental Services, Steamboat Springs, Colorado, [Unpublished report for MRRC], Price, Utah, 87 pp.
- American Cyanamid Company, 1989, Mining chemicals handbook: American Cyanamid Company, The Hibbert Group, Trenton, New Jersey, 184 pp.
- American Water Works Association, 1989, Standards for filtering material: American Water Works Association, Denver, Colorado, B100-89, 17 pp.
- Anderson, E. C., 1957, The metal resources of New Mexico and their economic features through 1954: New Mexico Bureau of Mines and Mineral Resources, Bulletin 39, pp. 54-55.
- Anonymous, 1993, New Mexico garnet development: Industrial Minerals, no. 309, p. 21.
- Anonymous, 1994a, As Cominco evaluates Altar garnet: Industrial Minerals, no. 324, p. 14.
- Anonymous, 1994b, Bitterroot update: Industrial Minerals, no. 327, pp. 14.
- Anonymous, 1995, Industrial minerals 1994-Garnet: Mining Engineering, v. 47, p. 545.
- Austin, G. T., 1994, Garnet; in Carr, D. D. (ed.), Industrial minerals and rocks: Society for Mining, Metallurgy, and Exploration Inc., Littleton, Colorado, pp. 523-533.
- Baker, T. G., 1993, Mobility of heavy metals in soils near the Hanover and Bullfrog tailings sites, Silver City, New Mexico: Unpublished MS thesis, New Mexico Institute of Mining and Technology, Socorro, New Mexico, 71 pp.
- Brandvold, L. A., 1974, Atomic absorption methods for analysis of some elements in ores and concentrates: New Mexico Bureau of Mines and Mineral Resources, Circular 142, 22 pp.
- California Air Resources Board, 1975, Method of test for abrasive media evaluation: Compliance Division, Sacramento, California, California test method no. 371-A, 14 pp. Test method No.
- Cetin, U., 1995, Recovery of garnet and sphalerite from Hanover mill tailings, Grant County, New Mexico: Unpublished MS thesis, New Mexico Institute of Mining and Technology, Socorro, New Mexico, 92 pp.
- Fattah, H., 1994, Royalstar Resources leads garnet pack: Industrial Minerals, no. 320, pp. 48-49.
- Faure, G., 1991, Principles and applications of inorganic geochemistry: MacMillan Publishing Company, New York, pp. 206-209.
- Federal Register, 1990a, Toxicity characteristic leaching procedure (TCLP), Rules and regulations: Part 302, Appendix II-Method 1311, June, v. 55, pp. 26,987-26,997.
- Federal Register, 1990b, Corrective action for solid waste management units at hazardous waste facilities; Proposed rule: Part 264, Section 26.4.521 (a)(2)(i-iv), Appendix A; Environmental Protection Agency, July, v. 55, no., 145, pp. 30,865-30,867.
- International Organization for Standardization, 1992, Preparation of steel substrates prior to the application of paints and related products-Surface preparation methods-Part Two: Abrasives for blast cleaning: ISO 8504-2 (Available from American National Standards Institute, New York), 6 pp.
- International Organization for Standardization (in preparation), Preparation of steel (and other) substrates prior to the application of paints and related products-Non-metallic blast-cleaning abrasives-Specifications-Part 10: Garnet minerals, ISO-DIS 11126-10.
- Ives, K. J., 1990, Testing of filter media: Journal of Water SRT-Aqua, v. 39, no. 3, pp. 144-151.
- Ives, K. J., 1993, Water filtration through granular materials: Industrial Minerals, no. 308, pp. 41-45.
- Jones, W. R., Herton, R. M., and Moore, S. L., 1967, General geology of the Santa Rita quadrangle, Grant County, New Mexico: U.S. Geological Survey, Professional Paper 555, 144 pp.
- Lueth, V. W., 1996, Garnet resource potential in southern New Mexico: This volume.
- Mathieu, G. I., Bosclair, M. R., and Wolfe, R., 1992, Geology, mineralogy, and processing of Mount Riordan garnet ores; in Hora, Z. D., Hamilton, W. N., Grant, B., and Kelly, P. D. (eds.), Industrial minerals of Alberta and British Columbia-Proceedings of the 27th Forum on the geology of the industrial minerals, Banff, Alberta: Alberta Geological Survey, Information Series 115, pp. 135-145.
- North American Mineral News, 1995, Garnet-New sources to cut loose: North American Minerals News, Metal Bulletin Plc, ISSN: 1358-334, May, pp. 10-12.
- O'Driscoll, M., 1993, Garnet-Set for blast off?: Industrial Minerals, no. 304, pp. 19-28.
- Ruby, M. V., Davis, A., and Nicholson, A., 1994a, In situ formation of lead phosphates in soils as a method to immobilize lead: Environmental Science and Technology, v. 28, pp. 646-654.
- Ruby, M. V., Sellstone, C., Bliss, L., Whitson, M., Shields, W. J., and Schoof, R. A., 1994b, In situ remediation strategies to reduce toxicity and exposure to lead in soil (abs.): Society for Environmental Geochemistry and Health, Abstracts and Authors, Rocky Mountain Conference, Salt Lake City, July 18-19, p. 22.
- Steel Structures Painting Council, 1991, Mineral and slag abrasives: Steel Structures Painting Council, Abrasive specification no. 1 (SSPC-AB 1), Pittsburgh, Pennsylvania, pp. 61-65.
- Turner, D. R., 1990, Geochemistry, stable isotopes, and fluid flow of the Empire zinc skarns, Central mining district, Grant County, New Mexico: Unpublished PhD dissertation, University of Utah, 295 pp.
- Turner, D. R., and Bowman, J. R., 1993, Origin and evaluation of skarn fluids, Empire zinc skarns, Central mining district, New Mexico, U.S.A.: Applied Geochemistry, v. 8, pp. 9-35.
- U. S. Bureau of Mines, 1995, Mineral industry surveys-Garnet: U.S. Bureau of Mines, May, (MINES FaxBack Document #410494), 2 pp.
- U. S. Environmental Protection Agency, 1994, Acid mine drainage prediction: U.S. Environmental Protection Agency, Office of Solid Waste, Special Waste Branch, Technical Document EPA 530-R-94-036; NTIS PB94-201829, 49 pp.
- Walder, I. F., 1993, Hanover mill tailings: Chemical and miner-



- alogical characterization and heavy metal mobility of a mill tailings (from Zn—Pb skarn deposits) and surrounding areas at Hanover, Grant County, New Mexico: [Unpublished report for MRRC], Price, Utah, 113 pp.
- Walder, I. F., 1994, Chemical and mineralogical characterization and heavy metal mobility of four mill tailings (from Zn—Pb skarn deposits) along Hanover Creek at Hanover, Grant County, New Mexico: [Unpublished report for MRRC], Price, Utah, 142 pp.
- Walder, I. F., and Chavez, W. X., Jr. 1995, Mineralogical and geochemical behavior of mill tailing material produced from lead—zinc skarn mineralization, Hanover, Grant County, New Mexico: *Journal of Environmental Geology*, v. 26, pp 1-16.

# Franklin Industrial Minerals— Mica plant operations in New Mexico

Gary L. Nelson\*

*Franklin Industrial Minerals—Mica Division P.O. Box 130, Velarde, New Mexico 87582, USA*

*\*Now at Hecla Mining Company, 6500 Mineral Dr., Coeur d'Alene, ID, 83814-8788*

**Abstract**—Franklin Industrial Minerals entered the mica business in 1990 with the acquisition of M.I.C.A. The operations consisted of a plant at Velarde, New Mexico, and patented mining claims and open-pit mine located some 30 mi north of the plant. Since the acquisition, Franklin has upgraded the facilities to focus on producing both an expanded line of products and consistently high-quality mica. This had included the installation of a state-of-the-art steam-tube fluidized-bed dryer, spirals for iron removal, a laboratory, and the installation of several environmental measures designed to improve community relations. Subsequently, Franklin acquired the mica and mineral operations of KMG Minerals, Kings Mountain, North Carolina. The two plants have been merged and are now being successfully operated as the KMG Mineral Division, Franklin Industrial Minerals.

## La empresa *Franklin Industrial Minerals*—Operaciones de su planta de producción de mica en Nuevo Mexico

**Resumen**—La empresa *Franklin Industrial Minerals* entró en la producción y comercialización de mica al adquirir la compañía *M.I.C.A.* en 1990. Consistía esta operación de una planta en Velarde, Nuevo Mexico, junto con pertenencias mineras y una mina a cielo abierto a unas 30 millas al norte de la planta. Desde que la adquirió, *Franklin* ha mejorado la operación con el fin de diversificar su línea de productos y producir mica de alta calidad. Se instaló una secadora moderna de lecho fluidizado a tubos de vapor, espirales para la remoción de hierro, y un laboratorio. Con el fin de mejorar relaciones con la comunidad, se instituyeron varias medidas para la protección del ambiente. Mas tarde, *Franklin* adquirió las operaciones de producción de mica y de otros minerales pertenecientes a *KMG Minerals* de *Kings Mountain*, en el estado de Carolina del Norte. Bajo el nombre *KMG Mineral Division, Franklin Industrial Minerals*, las dos plantas han sido combinadas en una sola operación próspera.

### Introduction

The mica mine and processing facility formerly known as Mineral Industrial Commodities of America, or M.I.C.A., Velarde, New Mexico, was purchased in July 1990 by Franklin Limestone Company. Franklin Limestone Company, a division of Franklin Industries (Nashville, Tennessee) was formally changed to Franklin Industrial Minerals in January 1992. Then in August Franklin purchased KMG Minerals, Kings Mountain, North Carolina. Both the New Mexico and North Carolina mica operations are now operated as the KMG Minerals Division, Franklin Industries.

In addition to the mica operation, Franklin Industrial Minerals has five calcium carbonate operations (two in Tennessee, two in Texas, and one in Florida) and a Specialty Products Division located in Dalton, Georgia; a large crushed limestone aggregate operation in Texas was also added in 1994. The calcium carbonate plants provide a variety of sized limestone products for various applications. The Dalton facility custom grinds calcium carbonate and aluminum trihydrate as well as housing Franklin's technical support and research department.

Mining by M.I.C.A. began in 1959 at several different sites. The current processing plant site was developed in the early 1980s, with the flotation mill going into service in 1984. Ore for the plant is mined on patented mining claims on U.S. Forest Service lands and trucked 30 mi to the process plant at Velarde, New Mexico.

### Geology and reserves

The mine is in the Kit Carson National Forest in Taos County, New Mexico, at approximately 8,600 ft above sea level. The primary orebody, which dips at an angle of about 35°, is a muscovite quartz schist and ranges from almost pure mica in the center to mica quartzite at the boundaries. During the patent process, the U.S. Forest Service geologists reported that the 10 patented claims (fee simple title) that constitute this mine contain the largest surface deposit of the high-quality muscovite mica reserves in North America.

The absence of any other major minerals in the schist and the high mica content, makes economical recovery readily achievable. Current proven reserves, based on drilling, are in excess of four million short tons (st) with recoverable product estimated at over 700,000 st. The mica itself is a fine-grained schist that exhibits an excellent white color after purification and processing.

### Mining

At the open-pit mine, a D-9 dozer is the primary piece of equipment. The dozer uses a ripper to excavate material that is not removable with the blade. Mica ore is pushed into a pile as it is being blended and stockpiled. Any overburden or inherent discolored "stringers" in the mine are removed and stockpiled separately.

A grizzly with 6 inch spacings is used to remove the oversize material. The <6 inch material passes through

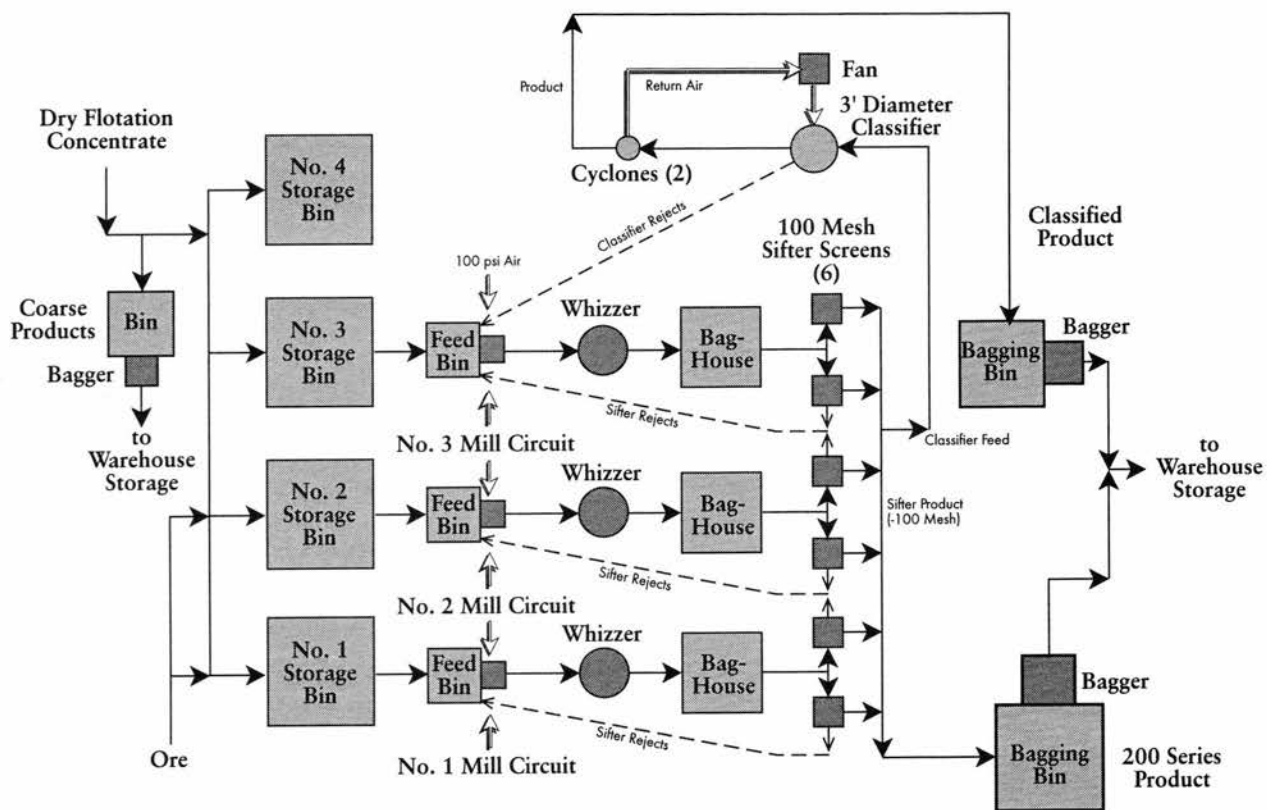

FIGURE 1—Flotation mill schematic of the Franklin Industrial Minerals—Mica Division, Velarde, New Mexico.

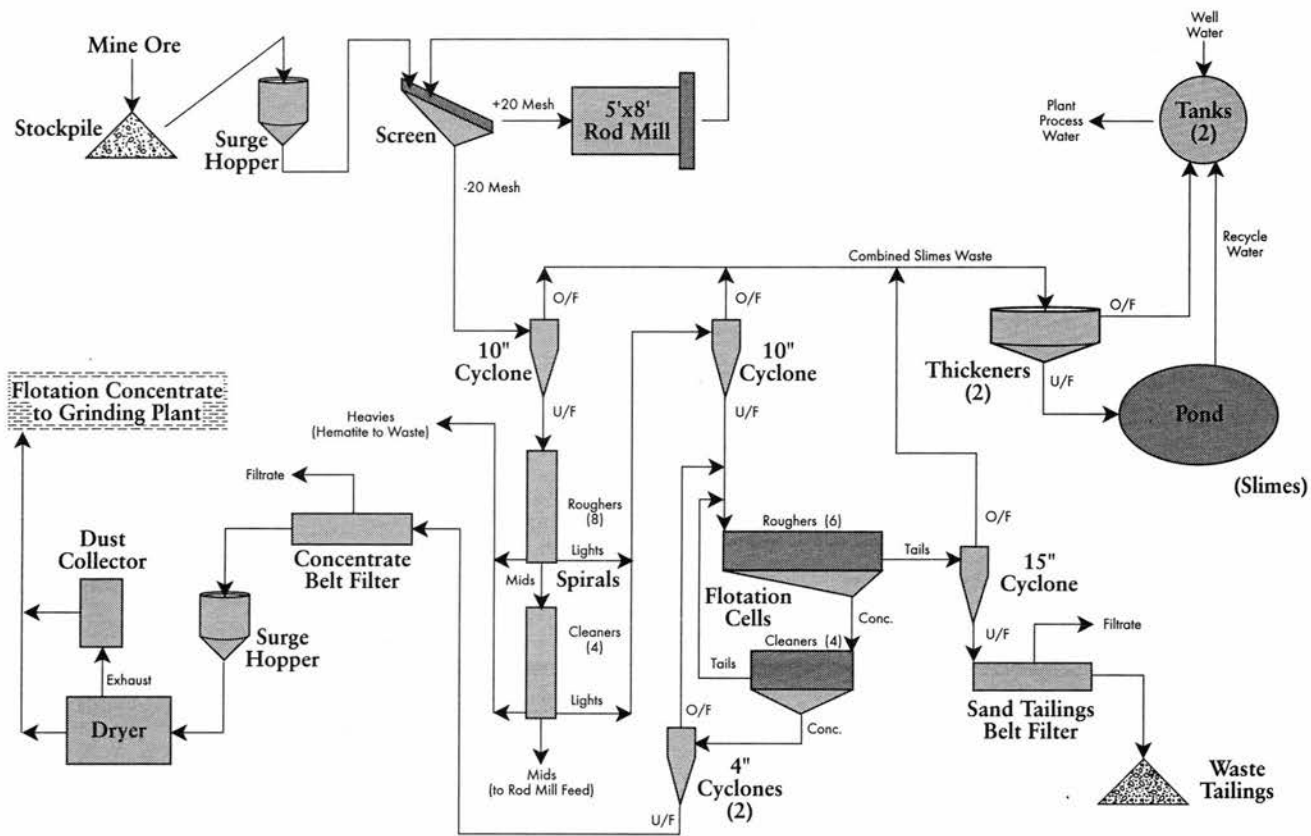

FIGURE 2—Grinding plant schematic of the Franklin Industrial Minerals—Mica Division, Velarde, New Mexico.

a double-deck screen and is sized to <1 inch. This sizing process upgrades the material to a mica content of the stockpiled ore to greater than 60%. Ore is transferred by a front-end loader from the stockpile to a truck that transports it 30 mi to the screening plant near the processing plant where it is again stockpiled. Actual mining is conducted between the months of April and November, with sufficient headfeed stockpiled to cover the remaining winter months. Plant headfeed levels are maintained at 2-4 weeks inventory levels, to allow for poor weather or equipment maintenance.

### Processing plant

The processing plant is about 35 mi north of Santa Fe, on New Mexico Highway 68 between Espanola and Velarde. It is situated near the Rio Grande at an elevation of approximately 5,500 ft. The basic plant consists of a flotation mill (Fig. 1) and grinding plant (Fig. 2). Additional facilities include buildings for warehousing of finished products and separate areas for concentrate drying and chemical storage.

The plant has undergone several changes and modifications since Franklin Industrial Minerals purchased the operation. The basic process and the principal changes that have been implemented since the acquisition are detailed in the section that immediately follows.

### Ore handling

The <1 inch ore from the mine is stockpiled within a partially enclosed berm. The primary purpose of the berm is to minimize fugitive dust loss due to high winds (particularly in the spring). As needed, the ore is transported by front-end loader to a belt-conveyor feed hopper fitted with a 6 inch grizzly. The grizzly is most useful in the winter months, when large chunks of frozen ore are possible. After the feed hopper, the ore is conveyed to a Hummer screen for final sizing through a 1 inch screen. The <1 inch fraction is then transported by a bucket elevator that feeds to a storage bin inside the flotation mill. This feed bin has a storage capacity of 5-8 hrs, depending on mill rate. The oversize, often consisting of chunks of frozen ore, is stockpiled until the spring thaw, when it is reintroduced to the circuit.

### Flotation mill

Using a metering screw for feed-rate control, ore is conveyed via belt and bucket elevators to a two-panel Derrick screen for size classification prior to grinding. The 0.28 inch screens make an approximate 30 mesh cut, with the oversize reporting to a 5 by 8 ft rod mill and the undersize reporting to desliming cyclones. The rod mill is run with a fairly light charge (approximately 25-30%) of 3 inch-diameter rods and solids of 40-45% in order to minimize the fraction of mica reporting to slimes (approximate <230 mesh fraction). The rod mill discharge is recirculated to a Derrick screen for classification.

The Derrick screen underflow fraction is passed in series through two 10 inch Krebs cyclones for desliming. The <230 mesh overflow from these cyclones is combined and reports to a thickener. The slimes are thickened with the assistance of chemical flocculants, and are then pumped to a waste pond for disposal. Thickener effluent, or overflow, reports to a process water tank for plant reuse. The underflow from the second cyclone is the feed to the flotation circuit. Flotation feed is diluted, the pH is adjusted with sulfuric acid, and an amine collector is

added to the rougher-cells feed box. The rougher circuit consists of six Gallagher 48 flotation cells. Rougher concentrate reports directly to a four-cell cleaner stage (also Gallagher 48) for further upgrading. Sand tailings discharge from the rougher cells is dewatered using a Krebs cyclone and an Eimco belt vacuum filter. The sand is then utilized in local construction applications or discarded as fill. Concentrate from the cleaner cells is dewatered similarly. Tailings from the cleaner cells are recirculated to the rougher cells feed box. The dewatered flotation concentrate is conveyed to the dryer circuit.

### Drying circuit

The dryer circuit at the Velarde plant is quite novel for the mica industry. The drying unit is a fluid-bed steam-tube dryer marketed by Heyl and Patterson. The fluid-bed dryer utilizes steam produced from a 200 hp boiler to preheat incoming fluidizing air and to provide additional indirect drying with two rows of finned steam tubes located in the fluidizing bed zone. The design provides complete concentrate drying at fairly low temperature; (<350°F), which insures no color or particle degradation of the flotation concentrate. Temperatures above about 600°F can result in a slight reduction in material whiteness as well as a potential loss in particle or flake integrity. Approximately 75% of the concentrate exits the dryer at the bed discharge, while the remaining 25% exits with the exhaust air and is captured in a dust collector. The two fractions are recombined and conveyed to storage bins in the grinding plant.

### Grinding plant

The grinding circuit utilizes a fluid-energy-milling concept for particle-size delamination and reduction. The current operation consists of three fluid-energy circuits in parallel. Dry mica is screw-fed directly into two opposing high-pressure air streams. The mica particles are ground and delaminated upon impact with each other in this high-energy environment. As the particles are ground, they are air-swept through a riser pipe into an air classifier where roughly a 100 mesh cut is made. Mica sized >100 mesh returns to the feed screws and is recirculated. Mica sized <100 mesh exits the air classifier and is collected in a baghouse. The product collected in the baghouse passes through gyratory sifter screens; two 100 mesh parallel on each mill circuit. The coarse rejects from the sifter return to the feed screws and are recirculated. The fine fraction, conveyed to a storage bin, is packaged as a standard 200 series product through a dedicated bagging unit. Currently, the product is packaged in 50 lb, multiwall, Kraft bags or 1 st supersacks. Product physical properties are controlled by variable-speed adjustments to both the mill-feed rate and air-classifier whizzer speed. The air used for grinding and conveying is furnished by one 450 hp compressor and four 200 hp compressors. The air is superheated prior to entering the grinding chamber.

A portion of the standard 200 series product is typically rerouted to an air-classifying circuit for additional processing in order to produce special products. A Sturtevant classifier is used to produce several different products containing specific particle-size distributions for a variety of different product applications. Product cuts are made at 325 and 400 mesh, and controlled by adjustments to the air flow, classifier rotor speed, feed particle size, and feed rate. Finished products are packaged by an

independent bagging unit. Due to the lower bulk-density characteristics of the classified materials, ranging from 11 to 15 lb /ft<sup>3</sup> (loose bulk density), a screw-auger packer is required for packaging.

### Warehouse and material handling

A warehousing facility adjacent to the grinding plant allows for the storage of sufficient inventory for each product line. The warehouse is also used for the storage of bag inventory—both 50 lb bags and 1 st supersacks as well as large maintenance items and test materials.

The products are shipped on pallets via various trucking companies to customers throughout the United States and Canada. Periodic shipments are made via rail facilities located in Albuquerque, New Mexico, mostly to overseas customers. Shipping containers are used for these overseas customers.

### Auxiliary equipment and facilities

The plant requires the use of a front-end loader for ore and waste handling. Two forklifts are used for material handling and various maintenance requirements. A 1 st truck has also been retrofitted with a tank for road-watering purposes.

A separate chemical-storage room was recently completed to house the limited quantity of chemicals used at the plant. Included is a 10,000 gal sulfuric-acid-storage tank in a containment area for bulk-handling purposes, as well as designated areas for flocculant, flotation amine, and pH control chemicals. A special effort has been made to utilize large tote-bin containers for these chemicals, to improve operator handling pertaining to safety procedures, and to reduce costs. The facilities for diesel, gasoline, and waste oil are all contained in one location for safe handling and proper containment.

The grounds immediately adjacent to the buildings have been equipped with a sprinkler system for fugitive-dust containment and vegetation irrigation. Additionally, magnesium chloride is periodically used on the plant road and high-traffic areas for dust control.

### Laboratory

A small control-laboratory building is located near the flotation mill and grinding plant. Routine process and product-quality-control test functions are conducted, and key variables are charted accordingly. The laboratory is equipped with particle-size-measuring equipment, both Rotap and Alpine machines, bulk-density-analysis equipment, ovens, weigh scales, pH meter, laboratory flotation machine, vacuum equipment, microscope, test equipment for boiler-water analyses, and other items. Specific test requirements for the flotation mill include mica grades of feed, concentrate, tailings, and moisture and impurity analyses. In order to track yields and recoveries, a flotation-mill-material balance is performed daily using composite sampling of key streams. In-process and product analyses conducted in the grinding plant include particle-size and bulk-density determinations. The product analyses are performed routinely during production, and additional lot-tests are performed for all products on a daily basis as well. Currently product analyses for optical properties and particle-size distributions using laser-light diffraction are performed at "sister" plants on a daily lot basis. An on-site color measuring instrument should be available shortly.

### Equipment modifications and improvements implemented

Since the operation was purchased by Franklin Industrial Minerals, several equipment modifications and plant improvements have been instituted. The Derrick screen was installed early in 1991 to provide a specific particle-size closed loop around the rod mill. As a result, a specific particle-size cut of about 30 mesh was realized for mill feed from the rod-mill circuit. This reduced the quantity of fines being produced, thus lowering the amount of plant losses in the slimes fraction. Additionally, mica losses to the flotation tailings were reduced because of the reduction of coarse mica particles in the mill feed. Particles of this size are less likely to float.

An undersized rotary dryer was replaced by a Heyl and Patterson fluid-bed dryer. The unit went into service in late January 1992, and is quite novel for the industry because a steam-tube configuration is included for additional drying. The dryer incorporates a boiler producing 150 psi steam for two specific purposes. Part passes through a heat-exchange area preheating the incoming dryer air stream. The remaining steam passes through finned steam tubes located in the fluidizing zone of the dryer bed.

When the plant was purchased, no capability existed to produce fine-particle-size and narrow-distribution classified products. Initially, a small 18 inch-diameter pilot-scale classifier was brought into the plant for product testing and development. As development of the fine-particle-size products progressed and were successful in the marketplace, a larger unit was purchased to meet production demands. The 18 inch pilot-scale unit was replaced by a 3 ft-diameter Sturtevant classifier, which went into service in February 1993. Production demands have required extensive use of the classifier since.

The general bagging facilities were modified following the installation of the classifier circuit. A new screw-auger bagger was installed in the classifier circuit to handle fluffy, lower bulk-density materials produced by this equipment.

In order to meet the demands of a more diversified product marketing base, a coarse-product circuit was developed and installed in mid-1993. The circuit allows flotation concentrate from the dryer to be separately processed and packaged. The material can be either directly packaged or routed through a sifter screen for specific particle-size-distribution requirements. A screw-auger packer is used in this application as well, and supersack packaging is also available.

Improvements to the flotation-mill ore-feeding system were made in the past 18 months. All the changes were directly related to plugging and maintenance problems caused by cold-weather operations. The ore-feed bin/grizzly was rebuilt and enlarged, and the conveyor feeding the Hummer screen was enlarged from an 18 inch to a 24 inch belt. Additionally, the bucket elevator was converted from a belt to a chain unit. Finally, appropriate discharge chutes and hopper sections within the circuit were lined with UHMW polyethylene sheets to improve material flow.

Laboratory equipment has been upgraded and improved to meet the in-process and finished-product quality-control requirements of the plant. Equipment for monitoring pH, pulp densities, measurement weights, and particle-size distributions have been upgraded. For example, an Alpine air-jet sieve unit has been acquired and

now replaces the Rotap screening equipment for particle-size analysis, and is now a primary quality-control tool.

### Under investigation

Several projects are currently under investigation for implementation within the process. They include areas of equipment improvement, specific process improvement, and product-quality improvement.

Desired adjustments in mining location and depth have increased the potential for hematite concentration in the mica product. This iron impurity, while still quite low in concentration, is present in sufficient quantity at the desired mining location to require separation and removal during plant concentration. Due to the significantly higher specific gravity of hematite compared to the mica and quartz constituents in the schist (approximately 5.0 vs. 2.8), the application is well suited to wet-spiral separation. Thus, a spiral circuit was inserted between the Derrick screen and rougher-flotation steps, spiraling the No. 1 cyclone underflow in a two-stage spiral rougher and scavenger circuit. The final spiral concentrate returns to the No. 2 cyclone for dewatering/ desliming prior to flotation.

Hematite separation and removal tests have also been performed on a high-intensity induced-roll magnet. While the tests were successful, the wet-spiraling technique proved more economic in practice. However, the same magnet proved highly successful in the paramagnetic separation of mica and quartz. The ability of the magnet successfully to separate mica entrained with quartz from pure mica particles has been of particular interest. This "upgrading" application is still under investigation.

Flotation circuit modifications and testing are ongoing. Recent equipment adjustments have included weir-level modifications and replacement of all the cell agitators. The desliming cyclones and feed pumps prior to the cells have also been adjusted to increase cyclone-feed pressures, improve particle sizing, and lessen the quantity of fines reporting to the waste stream. Limited testing on column flotation cells has also been initiated through an outside consultant. The initial work has centered on slimes recovery, although future testing will also consider the conventional rougher/cleaner cell applications.

Plant losses from cyclone desliming steps prior to flotation have received considerable attention. Several equipment methods for recovery of the >325 mesh fraction have been or are currently under investigation. Under the direction of the company's technical department, these recovery modifications include centrifugation, hydrosizing, wet screening, column flotation, cycloning, and magnetic separation.

### Product characterization

Franklin Industrial Mineral's Technical Department, located at the Specialty Products Division plant in Dalton, Georgia, has spent considerable time and effort developing an in-house program for mica-product characterization. The primary reasons for mica-product-characterization information, including both in-house and competitive products, are to understand better the specific physical variables of a given mica product and to correlate this information to various end-use application requirements. A significant variable for mica is the data associated with aspect ratio. A given mica particle's average particle-diameter-to-thickness ratio is considered one of the most

important variables for a mica product. This is simply due to the fact that mica use in most filler applications is predicated on the platy nature of the mineral, and is the primary reason for use in an application.

The aspect ratio number is formulated from evaluating average values for surface area, platelet thickness, mean particle-size diameter, and specific-gravity determinations. This characterization information is compiled periodically on all in-house products, as well as developmental products and competitive materials as is appropriate. The characterization information is currently considered proprietary.

Additional product characterization variables include product pH, purity, oil absorption, Hegman grind, bulk density, color analysis, whiteness, size distributions, and video prints. In addition to product development and customer application investigations, periodic analyses are performed on the staple product line. While some of the characterization data is considered proprietary, most of the information is available for customer use and is provided upon request.

### Product applications

Currently, the highest volume application for the plant's 200 series ground-mica products is joint-cement compound. The mica is used as a mineral filler primarily for improved cracking resistance in the compound, and has a white to off-white color. Additional 200 series product is sold for some plastic applications as well. The finer mica products produced from further classification, designated 325 and 400 series products, are primarily used in plastics, paint, rubber, and sealants.

In plastics, mica is used as a functional reinforcement filler. The platy structure of mica improves tensile and flexural strength and flexural modulus, and reduces heat distortion. In certain applications, mica is surface modified by chemically treating with an organo-silicon to enhance physical properties.

In paint (primarily exterior paints and primers), mica is used as a barrier pigment and to reinforce the paint film. Upon application and drying, the mica platelets tend to overlap and provide reduced moisture penetration and structural reinforcement. The reduced-moisture-penetration benefits paint films by providing metal primers with superior corrosion protection, reduced abrasion and blistering failures, and minimized peeling. Enhancement of structural reinforcement relates primarily to reduced cracking when drying, as well as reduced peeling and flashing upon aging. Additionally, mica in a paint absorbs ultraviolet light, greatly reducing the tendency of a paint to fade.

Coarse mica products (typically >200 mesh) are used in oil-well drilling muds, plastics, and certain small-volume applications. In drilling muds, mica acts as a sealant and prevents loss of circulation of the drilling fluid. The plastics application is primarily oriented to sound attenuation. In a specialty thermoplastic application for use in tile, countertops, and other houseware items, mica flakes are color-coated for aesthetic purposes prior to use as a filler. Flake material is also used by local pottery artists.

### Process quality-control and product quality-assurance

To meet the demands of improved productivity for the process operations and to maintain consistent finished

product quality-control standards, considerable improvements have been made in quality assurance and quality control. Routine procedures, sampling, and analytical requirements pertaining to key process variables have been implemented. Variables are also charted for control purposes, with the data being utilized for short- and long-term evaluations. Target values and specification ranges for important finished product variables are also evaluated in the same manner. In addition to daily, weekly, and monthly quality-control information, a quarterly report reviewing the major variables is published for internal review by management.

Specific quality-assurance information is provided to those customers requiring such verification. This may include "Certificate of Analysis" or "Certificate of Compliance" information based on the product lots shipped to the customer.

#### **Environmental responsibility**

Franklin Industrial Minerals has implemented several projects in New Mexico to reduce fugitive dust and noise pollution. A sprinkler system was installed in certain areas of the plant to reduce fugitive dust and promote vegetation growth. Additional berms have been constructed on-site near the ore stockpile areas to minimize fugitive dust as well. During high winds, chemical dust suppressants are used. Magnesium chloride is

sprayed on the main plant road and high-traffic areas within the plant.

With the surrounding community in mind, efforts have been made to reduce noise and heavy equipment operation during the evening. As examples, the plant front-end loader has been equipped with a strobe light for backup alarm purposes during non-daylight operation, and specific operational procedures have been implemented to minimize heavy equipment use during the night-shift (11:00 p.m.-7:00 a.m.)

#### **Summary**

Franklin has now operated the New Mexico mine and plant for over five years. While numerous changes and improvements have been made, particularly in process equipment and operation, the quality of the ore body and the positive future for mica have been confirmed. With the acquisition of KMG and the merger of the two mica product lines, numerous market synergies have been achieved. This has included the merging of distribution and networks and the expansion of export sales. KMG also maintains a state-of-the-art research facility in North Carolina that has served both locations well.

Franklin is pleased with the progress which has been made and is looking forward to participating in the continuing growth in the market for mineral reinforcements.



# Economic geology of perlite in New Mexico

## James M. Barker<sup>1</sup>, Richard M. Chamberlin<sup>1</sup>, George S. Austin<sup>1</sup>, and David A. Jenkins<sup>2</sup>

<sup>1</sup>New Mexico Bureau of Mines & Mineral Resources, New Mexico Tech, 801 Leroy Place, Socorro, New Mexico 87801-4796, USA  
<sup>2</sup>Grefco Inc., Lompoc, California 93436

**Abstract**—Perlite is an altered rhyolitic glass containing 2-5 wt.% water. It expands or "pops," when heated quickly to plasticity while evolving steam, to form lightweight, glass foam. Commercial perlite deposits in New Mexico are well-developed zones of chemical weathering (hydration) superimposed on highly permeable and thick glassy zones at the chilled upper surface and toes of high-silica-rhyolite lava flows and lava domes.

New Mexico perlite output, which is about 80% of the record 710,000 short tons produced domestically in 1994, is produced by three companies (Dicaperl, Harborlite, U.S. Gypsum) at four open-pit mines (No Agua Peaks [2], Grants, Socorro). Most unexpanded perlite produced in New Mexico is shipped primarily by rail mainly to expanders throughout North America. Some expanded perlite is shipped by Dicaperl from their sizing and expansion plant at Antonito, Colorado, about 27 mi north of No Agua Peaks.

The main producing area in New Mexico is at No Agua Peaks. It is from Pliocene high-silica-rhyolite lava flows. These consist of about 50 wt.% recoverable perlite mined by Dicaperl from the thinner western flows and about 20 wt.% recoverable perlite mined by Harborlite from thicker eastern flows. The smaller Socorro deposit mined by Dicaperl is a Miocene, glassy high-silica-rhyolite lava dome that is 95 wt.% microvesicular perlite. The Grants perlite deposit mined by U.S. Gypsum is part of a large, Pliocene, high-silica-rhyolite lava dome that consists of less than 5 wt.% perlite primarily in the glassy eastern toe of the dome.

## Geología económica de la perlita en Nuevo Mexico

**Resumen**—Perlita es un vidrio riolítico alterado que contiene de 2% a 5% por peso de agua. Al calentarlo rápidamente se ablanda, despidiendo vapor y se hincha o "estalla" para formar una espuma vitrea liviana. Los depósitos comerciales en Nuevo Mexico son zonas bien desarrolladas de alteración química (hidratación) superimpuestas sobre gruesas zonas vitreas en la cara superior y los frentes rápidamente solidificados de corrientes y domos de lava de riolita silícica.

Nuevo Mexico contribuye un 80% de las 710,000 toneladas cortas (*short tons*) de la producción doméstica registrada en 1994 por tres empresas (*Dicaperl*, *Harborlite* y *U.S. Gypsum*) en cuatro operaciones a cielo abierto (localizadas en No Agua Peaks [dos], Grants y Socorro). La mayor parte de la perlita no dilatada producida en Nuevo Mexico se remite por ferrocarril a plantas en America del Norte. *Dicaperl* también despacha perlita dilatada de su planta de clasificación y dilatación en Antonito (estado de Colorado), unas 27 millas al norte de *No Agua Peaks*.

*No Agua Peaks* es el distrito productor más importante en Nuevo Mexico. La roca de caja consiste de corrientes pliocenas de lava riolítica de alto contenido de sílice. *Dicaperl* produce de corrientes más delgadas en el oeste del distrito que contienen un 50% por peso de perlita recuperable. *Harborlite* explota las corrientes más gruesas del este del distrito que contienen un 20% de perlita recuperable. El depósito de Socorro, más pequeño que el anterior, pertenece a *Dicaperl*. Este yacimiento se aloja en un domo mioceno de riolita vitrea alta en sílice y consiste en un 95% de perlita microvesicular. El depósito de Grants, explotado por *U.S. Gypsum*, forma parte de un extenso domo plioceno de lava riolítica silícica que contiene menos del 5% de perlita concentrada principalmente en la base vitrea oriental del domo.

### Introduction

Commercial perlite is an altered high-silica rhyolitic volcanic glass that contains 2-5 wt.% water. Classical perlite is a variety of commercial perlite in which the spherical hydration geometry produced megascopic concentric fractures ("onionskin" texture). The geometry of wetted surfaces in pumiceous and granular (microvesicular) obsidians apparently inhibits the development of classic perlite textures during hydration by meteoric water. We recognize that most commercial perlite belongs to a special class of rhyolite known as high-silica rhyolite with 75-77.5 wt.% silica (Chamberlin and Barker, this volume). Perlite occurrences worldwide are associ-

ated with Tertiary through middle Quaternary continental volcanic fields (Breese and Barker, 1994; Breese and Piper, 1985).

Perlite was used in the late 19th century and perhaps in the 18th century (Howell, 1974) and was recognized as early as the 3rd century B.C. (Kadey, 1983). The modern industry was developed in the late 1940s. Perlite is mined by seven companies at nine operations in five western states. New Mexico accounts for over 80% of the record 710,000 short tons (st) mined in 1994 (Bolen, Harper, and Hatch, 1995). About 20% is mined in Arizona, California, Colorado, and Nevada. Perlite exports, primarily to Canada, were estimated to be 33,000 st, and

imports, primarily from Greece, were estimated to be 49,600 st in 1993 (Bolen, 1995). Most perlite is shipped to expansion plants near end users.

Crude perlite expands, or "pops," into glass foam when heated quickly to plasticity while evolving steam. In 1994 68 plants in 34 states expanded perlite (Bolen, 1995). Construction uses of expanded perlite accounted for 71% of total domestic sales. Expanded perlite used as filter aid accounted for 10%, while use as fillers and in agricultural and other markets accounted for 19%. Leading consuming states, in descending order of expanded perlite consumed or sold, were Georgia, Mississippi, Illinois, Pennsylvania, Alabama, California, Florida, and Virginia in 1994 (Bolen et al., 1995).

Sized perlite sold for an average of \$29.94/ st; expanded perlite averaged \$194 / st in 1994 (Bolen et al., 1995). Average prices (per st) for expanded perlite by end use are: low-temperature insulation \$494, fillers \$356; cavity-fill insulation \$325, horticultural aggregate \$298, concrete aggregate \$280, filter aid \$272, high-temperature insulation \$249, oil and water absorbent \$245, plaster aggregate \$198, acoustic tile \$152, and roof insulation board \$132 (Bolen et al., 1995).

### Perlite mining in New Mexico

New Mexico supplies perlite from three Tertiary deposits: a world-class deposit at No Agua Peaks in Taos County, north-central New Mexico; a smaller but high-yield deposit near Socorro; and a moderate-yield deposit near Grants (Fig. 1). The world's largest perlite deposit at No Agua Peaks (Whitson, 1982) sustains two mining operations. Perlite occurs on the top and flanks of each of the four (north, south, east, and west peaks) No Agua Peaks (Breese, 1984; Naert, 1974; Naert et al., 1980).

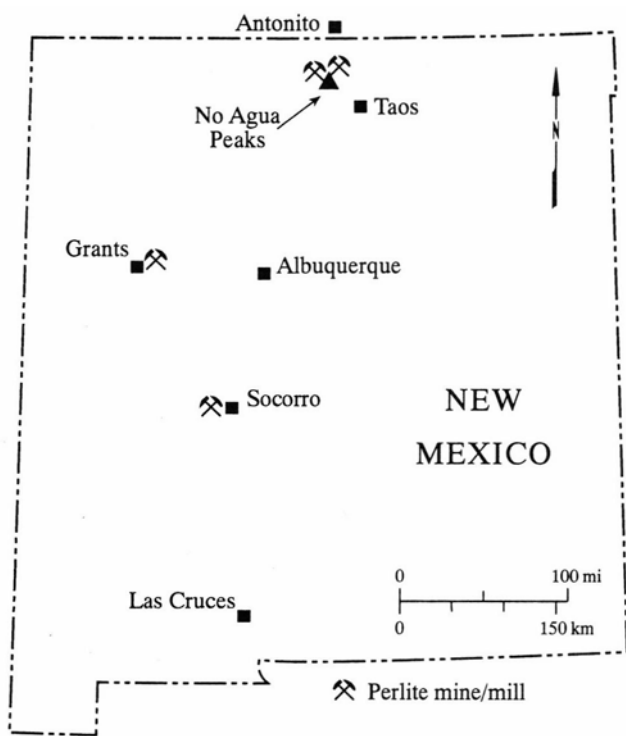

FIGURE 1—Active perlite mines in New Mexico. The output from the No Agua Peaks operations is trucked to the railhead at Antonito, Colorado, where Dicapertl also expands perlite. The Grants and Socorro operations ship their output by rail directly from their plants.

Dicapertl, the perlite unit of Grefco, produces perlite from a open-pit mine in the low hills on the western flank of west peak. Harborlite operates the former Manville or Celite open-pit mine on the crest and outer flanks of west, east, and south peaks. Dicapertl also mines (open-pit) the Socorro deposit near Socorro, Socorro County, central New Mexico, and U.S. Gypsum operates an open-pit mine on East Grants Ridge near Grants in west-central New Mexico. The following discussion draws heavily on Austin and Barker (1995) with updates by some New Mexico perlite producers.

All current New Mexico perlite producers operate open pit mines although the perlite mine at Brushy Mountain (Whitson, 1982), about 12 mi east of No Agua Peaks, was both an open pit and underground operation of Silbrico until the late 1980s. The perlite ore is usually extracted by scrappers and/or rippers but some ore must be drilled and blasted. Some producers crush the ore at the mine while others crush at the mill. Most truck crude perlite from the mine to the plant, but some pits are near enough to use conveyor belts or to dump from hauling or mining equipment directly into the crusher. At the mill, perlite is crushed to about -6 inches, dried to remove free moisture (the combined moisture for expansion is unaffected), recrushed, and screened. Oversize is usually reground. All but one company (U.S. Gypsum) produce more than one size of crude perlite. Some operations have expanders at or near the mill, but most move crude perlite to expanders in various parts of the country and to Canada and Mexico.

### Dicapertl perlite (No Agua Peaks, New Mexico; Antonito, Colorado)

General Refractories Co. (renamed Grefco) opened the El Grande mine (Fig. 2) at No Agua Peaks in 1958. The mine is on patented claims and other fee lands comprising about 1,200 acres. The El Grande mine is in sec. 15 T29N R9E on the southwest flank of the No Agua Peaks volcanic center (Breese, 1984; Naert, 1974; Naert et al., 1980). Grefco recently assigned perlite mining and milling to its Dicapertl subsidiary. The mine has large reserves of dominantly granular perlite with some pumiceous perlite at the eastern boundary of the property with Harborlite. Obsidian in vertical lenses is locally abundant on the north side of the main pit. The surface has been lowered about 150 ft over the approximately 400 acre mining area. Parts of the main pit have only 7-10 ft of ore remaining, but other areas have at least



FIGURE 2—View from the Dicapertl open pit at No Agua looking east toward west peak.

150 ft left to mine. Although most mining requires ripping with a Caterpillar D8L tractor, some perlite on the south edge of the pit is blasted with ammonium nitrate—fuel oil (ANFO). Two Caterpillar 631 scrapers (often pushed with the D8L, although they can scrape the ore alone) pick up and move the ore to the screening plant near U.S. Highway 285 on the west side of the pit. Three people are employed in the open pit.

Scrapers drop crude perlite over a grizzly (+14 inches) and help crush oversize as their tires pass over it. The primary jaw crusher below the grizzly reduces the perlite to about —2 inches. A conveyor belt feeds a hopper before crude perlite is drawn out to two inclined rotary dryers (8 x 53 ft and 6 x 45 ft). The dryers, fueled with a 50/50 mixture of No. 6 fuel oil and reclaimed oil, reduce free moisture (40 st/hr) from about 12 wt.% (winter) or 6 wt.% (summer) to less than 0.5 wt.% at a maximum temperature of 225°F. The dried perlite is screened and the +6 mesh is reground in a turbocrusher. The —6 mesh perlite is screened into seven fractions (ranging from 8 to 200 mesh) and conveyed to seven 100 st storage tanks. Perlite in the tanks can be reground to meet surges in demand for a particular size, blended to about 30 standard sizes, or custom-blended. The screening plant produces about 200,000 st /yr of sized crude perlite and employs 24 people.

Two to three bottom-dump trucks are under contract to move the crude perlite from the screening plant to the railhead and expansion plant just south of Antonito, Colorado, 25 mi to the north. The crude perlite is dumped and moved by conveyor belt and elevators to one of 10 storage bins at the Antonito facility. Nine bins hold 100 st each and the tenth holds 2,000 st. Most (88%) perlite is loaded into railcars for shipment to expanders in other states; 7% is expanded on site. Railcars are usually 100 st bottom-dump type, but some (1 to 2 cars/wk) are leased 100 st pressure-differential (PD) railcars for fine-grained perlite (Fig. 3). About 5% of crude perlite is shipped in 30 st trucks to customers, commonly on either customer or contract-carrier trucks. Nineteen people work at the Antonito expansion plant.

The Antonito facility includes two vertical expanders (18.5 inch and 30 inch diameters) that are operated on the second and swing shifts. The first shift (day shift) performs maintenance and loads railcars and trucks. Expanded perlite is bagged and shipped to California, Colorado, Connecticut, Idaho, Kansas, Montana, New Mexico,

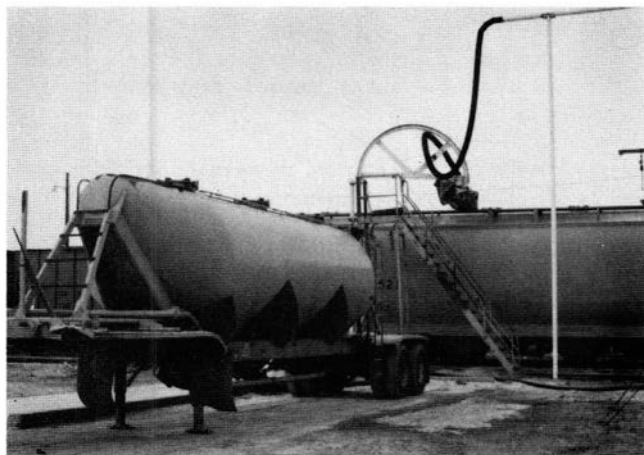

FIGURE 3—Pressure differential (PD) railcars being loaded with fine perlite at the Dicaperl plant at Antonito, Colorado.

New York, North Carolina, Oregon, Texas, Washington, Canada (Ontario), and Mexico. The expanded perlite is shipped mainly by truck in 25, 20, and 18-20 lb paper bags (2-ply, Kraft). Trade names of expanded perlite bagged at Antonito are "Dicaperl" for horticultural or fillers in 4 ft<sup>3</sup> bags and "Dicalite" in smaller bags by weight for filter aid. About one railcar of expanded perlite is shipped from Antonito each week.

Dicaperl ships about 20% of their crude product to Grefco-owned Chemrock Corp. plants in Florida, Indiana, Maine, and Tennessee. About 80% of the product goes to outside customers in Florida, Idaho, Illinois, Indiana, Maine, Massachusetts, Missouri, North Carolina, Ohio, Oregon, Pennsylvania, Tennessee, Texas, and Wisconsin. About 50-60 railcars of crude perlite are shipped from Antonito weekly.

About 50% of Dicaperl perlite is used in acoustical ceiling tile, 32% as block fill and other aggregates, 10% as horticultural perlite, and about 8% as filter aid. Perlite filter aids are slowly losing ground to diatomaceous earth. Microspheres of expanded perlite form a very small but growing, high-value market, primarily as fillers in plastic.

#### Harborlite (No Agua Peaks, New Mexico; Antonito, Colorado)

The Harborlite mine and screening plant is at No Agua Peaks about 24 mi south of Antonito, Colorado, and just northeast of Dicaperl. The mine was opened about 1952 or 1953 at north peak, northeast of the plant. The hilltop perlite on north peak, has excessive obsidian so mining ceased in 1981. Harborlite has about 1,500 acres of surface rights and additional 500 acres of mining rights on the No Agua Peaks. Mining has disturbed 300 to 400 acres.

Since 1981 Johns Manville Corporation, the owner at the time, and subsequent owners or subsidiaries (Celite and now Harborlite) concentrated on the flanks of south peak, at the west (Area A) and east (Area B) sides, and west Peak. The ore here is both granular and pumiceous, although some "classical" perlite is found at the core of the hills. In general, a lateral progression from denser perlite to granular to pumiceous exists from south peak southward. Some fine-grained, gray-to-clear obsidian is present in the "classical" and granular perlite, but the pumiceous perlite contains virtually none.

The flanking flows are mined inward toward the core of the hill until overburden is too thick to strip. When the total Harborlite lease area and extraction rate are considered, at least a 20 year supply of perlite is present. Perlite breccia on the southern flank of west peak is similar to adjacent Dicaperl ore; the east edge of the Dicaperl mine lies on the west flank of west peak. Perlite is ripped 70-80% of the time except for the hardest classical perlite (west peak is all ripped; some blasting is needed at south peak). Blasting, using ANFO, accounts for 20-30% of ore mined. A Komatsu 365 tractor with three rippers loosens the ore. Perlite is loaded with Caterpillar 992B front-end loaders with 10 yd<sup>3</sup> buckets onto three Euclid R50 mine trucks (50 st) for the 2 mi haul to the screening plant (Fig. 4).

At the screening plant, trucks deliver ore to an approximately 25,000 st stockpile. A Caterpillar 988 front-end loader (tire) moves ore to a grizzly (-2 ft) over a primary jaw crusher. Most of the +2 ft perlite is broken by loader (tire) traffic over the grizzly. The primary crusher reduces the perlite to —4 inch ore later screened to —0.5 inch.



FIGURE 4—Truck being loaded by front-end loader at the Harborlite open pit, No Agua Peaks. The highwall behind vehicles marks local pit margin related to high overburden ratios.

Sized crude perlite is trucked 27 mi from the No Agua screening plant to the railhead at Antonito, Colorado. Harborlite has six tractors that move two twin-bottom-dump trailers, five sets of 15 st bottom-dump pup trailers, and two pressure-differential (PD) trailers. Typically, only two to three trucks haul crude perlite between the mine/mill and the crushing plant. The ore is dumped by truck or Caterpillar 910 front-end loader into either a coarse or a fine circuit and moved by conveyor belt over a vibrating centron and into 11 silos that store dried and sized perlite ore, which is in seven standard sizes that can be blended to customer specifications. Multiple samples are taken from all railcars as they are loaded, allowing immediate adjustment and recording what was sent to customers. Testing facilities are extensive and include a lab expansion furnace to aid in product and ore-grade control. Perlite is rescreened a last time during loading into bottom-dump or 100 st PD railcars at the rate of about 30 bottom-dump and 1-2 PD railcars per week. Less than 5% of the ore is shipped by truck, mostly to local or small markets or those lacking rail service. Eight employees work at the Antonito facility.

Harborlite supplies crude perlite to customers in California, Florida, Illinois, Minnesota, Mississippi, Pennsylvania, and Texas. Some customers in California and Texas take fine-size perlite in PD cars. All perlite from the Harborlite No Agua mine is sold to outside customers. About 50% goes into acoustical tile, 30% into fesco (roof) board, 10% into filter aids, 5% into silica flux at foundries, 5% into horticulture, and a very small amount for microspheres. Perlite imported from Greece has little impact on markets at the present time, although some customers accept perlite from both Harborlite and Greece.

#### Dicaperl Perlite (Socorro, New Mexico)

The Dicaperl Socorro mine and screening plant is on the flank of Socorro Peak in sec. 27 T3S R1W. The mine is adjacent to the plant, which together employ 30 people, and occupies 70-90 acres on patented claims (Weber, 1963; Chamberlin, 1980, 1981). The Socorro mine was one of the first perlite mines in the United States when it opened in 1949, but it was closed from 1959 to 1975. A geothermal test well drilled in 1978 reportedly intercepted 387 ft of perlite near the center of the present pit (William Nowell, pers. comm. 1978). This drill hole thickness plus about 300 ft of perlite exposed above the pit floor suggest a total perlite thickness of over 600 ft for

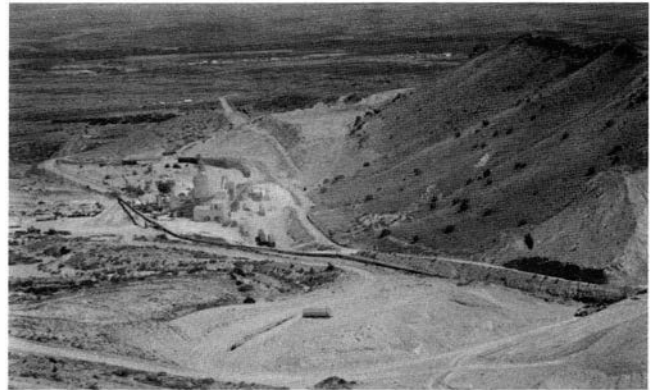
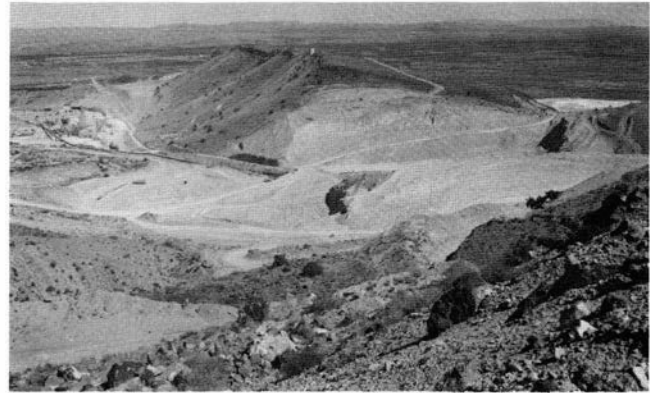

FIGURE 5—A. Panorama of the Socorro open-pit mine operated by Dicaperl. View is southeast from the flank of Socorro Peak. The oldest tailings are the white wedge along U.S. Highway 60 at the upper right. B. Detail of plant area from 5A. A conveyor belt transfers mine-run ore from the grizzly (right) to the plant surge pile (left). The main pit is to the right of the grizzly. The scraper is about to drop mine-run perlite ore onto the grizzly. A train is approaching the plant between the surge pile and the hill in the middle ground. The southern portions of Socorro are in the background.

the Socorro deposit. This estimate may be exaggerated by previously unrecognized faults in the deposit, but well-exposed perlite reserves are substantial.

A mining crew of three works half a shift to replenish the surge pile and then finishes with reclamation work. Perlite is ripped with a D9 Caterpillar tractor, and two scrapers move it to the primary crusher near the bottom of the pit. The scrapers are Caterpillar 631B and 631D with a screw auger for large or hard perlite. A grizzly passes — 12 inch perlite to the primary jaw crusher where it is reduced to — 2 inches. A covered belt conveys the perlite to a seven-day surge pile near the plant (Fig. 5). A vibratory feeder below the surge pile moves ore into the plant where it is screened to — 3/8 inch. The +3/8 inch ore is recycled to a vertical impact crusher and then over the 3/8 inch screen. The crushed perlite is dried in a 400°F rotary dryer that reduces the free moisture to 0.25 wt.%. Discharged perlite has a temperature of about 250°F. The dryer is fired with waste crankcase oil. Dry — 3 / 8 inch perlite is screened again in one of two banks of screens and routed to storage. Eight products are stored in 12 tanks for blending to customer specifications.

About 130,000 st of crude perlite of all sizes were sold in 1992. Close to 210,000 st will be sold in 1995. Addition of regrind circuits has added capability to match surges in demand for a particular grade. The capacity of the plant is 45 short tons per hour (stph), dropping to 35 stph if

intense regrind is underway (maximum of 550 st per day [stpd] of crushed and sized perlite). A Santa Fe Railroad spur extends about 2 mi from the main line at the center of Socorro to the Dicaperl mill (Fig. 5).

About 98% of crude perlite is moved from Socorro to customers by rail, primarily in 100 st bottom-dump railcars. Some is moved in PD railcars for pneumatic unloading of finer sizes. A Dresser 520 front-end loader moves railcars and product around the plant. About 2% of crude perlite is trucked to customers requiring perlite in 50 lb sacks or 1 yd<sup>3</sup> super sacks. Dicaperl expansion plants are in Lafayette, Louisiana, and Jackson, Mississippi, and they take about 10-15% of the total crude perlite production. Customers for the Socorro perlite are in Alabama, Arizona, California, Colorado, Florida, Georgia, Illinois, Indiana, Iowa, Kentucky, Michigan, New Mexico, Oklahoma, Pennsylvania, Tennessee, Texas, and Wisconsin. About 10% of the product is exported to foreign countries, principally Canada, with a small amount to Mexico. About 60% of the Socorro Dicaperl output goes for ceiling tile. Most of the remainder is used in horticulture. A minor amount goes into filter aids, wallboard, and pipe insulation.

#### U.S. Gypsum (Grants, New Mexico)

The U.S. Gypsum (USG) operation at Grants, New Mexico, began in 1953 when USG bought about 1,600 acres (about 600 acres in perlite) of patented claims from the Pumice Corporation of America (Barker et al., 1989). PCA operated a pumice mine on the south side of East Grants Ridge. USG did not operate the pumice facility, but did open a perlite mine on a low hill at the east end of East Grants Ridge called Hill No. 7. Perlite production peaked in 1957 and has since decreased steadily to about 3,850 st mined in 1992. The present mine and mill are operated by four employees.

The open-pit mine covers 200-300 acres and has eight 25 ft benches (Fig. 6). The top of the original hill was about 200 ft above the base of the present mine. At present the mine is operated by 1 to 2 people who work both as miners and truck drivers. A Caterpillar 988A front-end loader is used to mine the perlite ore and move it to a Mack tractor with a 26 ft end-dump trailer. The ore, which is granular to pumiceous with no obsidian, is fractured in place and is easily broken by the loader, so blasting is unnecessary.

The crude perlite is trucked about 8 mi to the processing plant adjacent to the Santa Fe Railroad loading facility in Grants, where it is stored in a 0.5 acre stockpile.



FIGURE 6—View of the U.S. Gypsum perlite mine looking southeast along snow-covered East Grants Ridge.

An Allis Chalmers 745 front-end loader reclaims from the stockpile and dumps into a hopper that feeds a Nico-feeder Universal 3042 jaw crusher that reduces the ore to -4 inches. A conveyor belt moves the crushed perlite to a Tyrock screen that separates the ore into two streams at about 3/4 inch. The +3/4 inch perlite is reground in a Hydrocone 651 cone crusher and dumped into the circuit above the Tyrock screen. The -3/4 inch fraction is stored in one of two tanks. Stored ore is later removed from below into a 35 ft rotary dryer that is heated with natural gas. The perlite contains about 6 wt.% free moisture as it enters the dryer and has less than 0.5 wt.% when it leaves. Dried ore then goes to one of three roll crushers in series with four hammer screens producing the final size of -0.5 inch to +300 mesh (GA-1). Perlite in four sizes was produced, but current production is only in the GA-1 size. The -300 mesh material and baghouse fines are trucked to the mine and used as road material, or are dumped and covered.

Perlite is shipped from the Grants crushing plant primarily to USG plants in Indiana, New York, Ohio, and Texas, where it is expanded and used in Thermofill plaster. The ore expands to 6-9 lbs / ft when expanded at 1,300-1,325°F. About 20% of the 1992 shipments of 3,850 st went to a customer in Missouri. About 98% of production leaves Grants in 100 st bottom-dump railcars at the rate of 2-3 cars per month. The price for crude perlite to local customers using trucks is around \$50/st FOB plant.

#### References

- Austin, G. S., and Barker, J. M., 1995, Production and marketing of perlite in the western United States; *in* Tabilio, M., and Dupnas, D. L. (eds.), Proceedings of the 29th Forum on the Geology of Industrial Minerals: California Department of Conservation, Division of Geology, Special Publication 110, pp. 39-68.
- Barker, J. M., McLemore, V. T., Wilson, M. L., and Austin, G. S., 1989, East Grants Ridge—A mineral potpourri: New Mexico Geological Society, Guidebook 40, pp. 325-329.
- Bolen, W. P., 1995, Perlite; *in* Mineral commodity summaries 1994: U.S. Bureau of Mines, pp. 126-127.
- Bolen, W. P., Harper, V. C., and Hatch, R. L., 1995, Perlite, Annual review 1994: U.S. Bureau of Mines, Mineral Industry Surveys, 4 pp.
- Breese, R. O. Y., and Barker, J. M., 1994, Perlite; *in* Carr, D. D. (ed.), Industrial minerals and rocks, 6th ed.: Society for Mining, Metallurgy, and Exploration, Littleton, Colorado, pp. 735-749.
- Breese, R. O. Y., 1984, Rhyolite domes and flows at No Agua Peaks, New Mexico: New Mexico Geological Society, Guidebook 35, pp. 373-374.
- Breese, R. O. Y., and Piper, J. R., 1985, Occurrence and origin of perlite: Society of Mining, Metallurgy, and Exploration, Littleton, Colorado, Preprint 85-359, 12 pp.
- Chamberlin, R. M., 1980, Cenozoic stratigraphy and structure of the Socorro Peak volcanic center, central New Mexico: Unpublished PhD dissertation, Colorado School of Mines, 532 pp. [New Mexico Bureau of Mines and Mineral Resources, Open-file Report 118].
- Chamberlin, R. M., 1981, Cenozoic stratigraphy and structure of the Socorro Peak volcanic center, central New Mexico—A summary: New Mexico Geology, v. 3, pp. 22-24.
- Howell, W. R., 1974, The early history of the perlite industry: [Unpublished address], Perlite Institute, Colorado Springs, Colorado, April 21.
- Kadey, F. L., Jr., 1983, Perlite; *in* Lefond, S. J. (ed.), Industrial minerals and rocks, 5th ed.: Society for Mining, Metallurgy, and Exploration, Littleton, Colorado, pp. 997-1015.
- Naert, K. A., 1974, Geology, extrusion history, analysis of perlites from No Agua, New Mexico: Unpublished PhD disserta-

- tion, Pennsylvania State University, State College, Pennsylvania, 223 pp.
- Naert, K. A., Wright, L. A., and Thornton, C. P., 1980, Geology of the perlite deposits of the No Agua Peaks, Taos County, New Mexico: New Mexico Bureau of Mines and Mineral Resources, Open-file Report 162, 88 pp.
- Weber, R. H., 1963, Geologic features of the Socorro perlite deposit: New Mexico Geological Society, Guidebook 14, pp. 144—145.
- Whitson, D., 1982, Geology of the No Agua Deposit at No Agua Peaks, New Mexico; *in* Austin, G. S., compiler, Industrial rocks and minerals of the Southwest: New Mexico Bureau of Mines

# Genetic aspects of commercial perlite deposits in New Mexico

Richard M. Chamberlin and James M. Barker

*New Mexico Bureau of Mines & Mineral Resources New Mexico Tech, 801 Leroy Place, Socorro, New Mexico 87801-4796, USA*

**ABSTRACT**—New Mexico supplies perlite from three commercial deposits: a world-class deposit at No Agua Peaks in Taos County, a smaller but high-yield deposit near Socorro and a moderate-yield deposit near Grants. We interpret commercial perlite deposits in New Mexico as nothing more than chemically weathered (hydrated), glass-mantled, *high-silica rhyolite* volcanoes of late Cenozoic age (3.3-7.8 Ma) that are accessible to open-pit mining. The extreme viscosity of high-silica rhyolite lava (75.0-77.5 wt.% SiO<sub>2</sub>) favors formation of very thick glassy zones across the chilled surfaces of the slowly extruded flows. Perlite is not a primary igneous rock; it is formed by the slow diffusion of meteoric water at low temperature into nearly anhydrous primary obsidian.

The maximum economic potential of a perlite deposit (tonnage of accessible glass) is largely predetermined by the eruptive history of its parent volcano. Glassy, subhorizontal tops of microvesicular (i.e. permeable), high-silica lava flows are the most favorable precursors of commercial perlite deposits. Large, steep-sided, high-silica lava domes are much more common than high-silica flows, but the large domes yield relatively little commercial perlite because their complex cooling histories form an intimately interleaved mixture of glass and crystalline rhyolite. Numerous investigations demonstrate that high-silica rhyolite magma chambers contain strong, vertically oriented, chemical gradients prior to eruption. For example, rubidium is strongly concentrated at the top of the chamber, thus the initial eruption is highest in Rb, and the last magma to reach the surface is lowest in Rb.

Most of New Mexico's perlite production is from 3.9 Ma high-silica rhyolite lava flows at the No Agua Peaks volcanic center. The primary vent at No Agua is defined by a 270 m high Rb-rich composite lava dome, known as west peak, which contains minor perlite reserves. Slightly less Rb-rich and hotter lava then squeezed out from under the west flank of the dome to form relatively thin (75 m) but highly vesicular lobate flows that now consist of about 50% recoverable perlite mined by Diaperl. Finally, Rb-poor lavas were extruded from a large radial dike on the northeast flank of the dome. These thicker (120 m) flow lobes (mined by Harborlite) contain about 20% recoverable perlite.

The relatively small Socorro deposit (mined by Diaperl) consists of 95% microvesicular perlite and lacks the crystalline core common to most larger lava domes. The Socorro deposit is a zone of weathering (hydration) superimposed on a 7.85 Ma, glassy high-silica rhyolite lava dome at least 90 m thick and about 840 m in diameter. Sedimentation completely buried the high-silica lava dome by about 4 Ma, it was then uplifted along a Quaternary fault zone and exhumed.

The Grants perlite deposit (mined by U.S. Gypsum) is part of a large high-silica rhyolite lava dome that consists of over 95% crystalline rhyolite. The glassy eastern toe of the dome yields moderate amounts of perlite. This 3.3 Ma lava dome, 210 m high and 2.4 km wide, was buried by ash and lava flows from the Mount Taylor stratovolcano and was later exhumed.

## Genesis de yacimientos de perlita comerciales en Nuevo Mexico

**Resumen**—Nuevo Mexico (N.M.) produce perlita de tres yacimientos comerciales. De estos, el yacimiento de *No Agua Peaks*, en el condado de Taos, es de importancia mundial. Otro yacimiento, más pequeño pero de alto rendimiento, está cerca de Socorro. Un tercer yacimiento, de rendimiento moderado, está cerca de Grants. Interpretamos los yacimientos de perlita comerciales en N.M. como nada más que volcanes de *riolita muy silicica*, con caps superficial de vidrio volcánico químicamente alterado (hidratado), de edad cenozoica superior (3.3-3.7 millones de años [Ma]) y explotables a cielo abierto. La extrema viscosidad de la lava riolítica altamente silicica (75.0-77.5% por peso de sílice) permite que se formen zonas vitreas muy gruesas en el exterior de corrientes de lava lentamente expulsadas cuando entran en contacto con la atmósfera. Perlita no es una roca ígnea primaria, antes Bien, se forma por la lenta difusión de aguas meteóricas de Baja temperatura por la obsidiana primaria casi anhidra.

El máximo potencial económico de un yacimiento de perlita (tonelaje de vidrio accesible) es función de la historia eruptiva del volcán en que se formó. Las zonas periféricas subhorizontales vitreas de corrientes de lava muy silicica y microvesicular (y, por eso, permeables) son los precursores más favorables de los yacimientos comerciales. Por contraste, domos grandes de costados empinados de lava muy silicica, aunque mucho más frecuentes que las corrientes de lava silicica, son mucho menos rendidores de perlita comercial porque su compleja historia de enfriamiento produce una mezcla de delgadas capas intercaladas de vidrio y riolita cristalina. Numerosas



investigaciones han demostrado que antes de entrar en erupción las cámaras de magma riolítico altamente silícico poseen fuertes gradientes químicos verticales. Así, por ejemplo, rubidio está concentrado hacia la cuspide de la cámara, de modo que la erupción inicial es la más rica en rubidio y la última fracción de magma en llegar a la superficie es la más Baja.

La mayor parte de la producción de perlita en N.M. proviene de las corrientes de lava riolítica silícica (de 3.9 Ma de edad) que emanan del centro volcánico de *No Agua Peaks*. El orificio primario de *No Agua* está en un domo compuesto de lava rica en rubidio, de 270 metros de altura, conocido como *pico occidental*; este contiene reservas menores de perlita. Luego, lava más caliente y menos rica en rubidio emanó de por debajo del flanco oeste del domo para formar corrientes lobuladas relativamente delgadas (75 metros) pero altamente vesiculares que ahora consisten de unos 50% de perlita recuperable minada por *Dicaperl*. En una fase eruptiva final, lavas pobres en rubidio salieron de un gran dique radial en el flanco noreste del domo. Estos lóbulos más gruesos (120 metros), minados por la empresa *Harborlite*, contienen unos 20% de perlita recuperable.

El yacimiento relativamente pequeño de Socorro, trabajado por la empresa *Dicaperl*, consiste de 95% de perlita microvesicular y carece del núcleo cristalino que caracteriza a la mayoría de los domos de lava más grandes. El yacimiento de Socorro consiste de una zona de alteración (hidratación) superimpuesta en un domo de lava de riolita silícica vitrea de 7.85 Ma, de espesor mínimo de 90 metros y de unos 840 metros de diámetro. Hace unos 4 Ma, sedimentos habían tapado el domo completamente. Luego fue elevado a lo largo de una falla cuaternaria y exhumado.

El depósito de Grants (minado por la empresa *U.S. Gypsum*) es parte de un gran domo de lava riolítica silícica que consiste de un 95% de riolita cristalina. La base oriental vitrea del domo produce cantidades moderadas de perlita. Este domo tiene 3.3 Ma, altura de 210 metros y ancho de 2.4 kilómetros. Fue tapado por cenizas y corrientes de lava del estratovolcán de *Mount Taylor* y exhumado más tarde.

### Introduction

Commercial perlite is a water-rich (2-5 wt.% H<sub>2</sub>O), volcanic glass of normal rock density that expands or "pops" when heated in a furnace. Expanded perlite is a low-density anhydrous glass foam used chiefly in light-weight construction materials. Commercial perlite is not a primary igneous rock. It is predominantly formed by the slow diffusion of meteoric water at low temperature into nearly anhydrous primary obsidian (Friedman et al., 1966; Kadey, 1983; Breese and Piper, 1985; Breese and Barker, 1994).

New Mexico supplies perlite from three commercial deposits: a world-class deposit at No Agua Peaks in Taos County, a smaller but high-yield deposit near Socorro; and a moderate yield deposit near Grants (Fig. 1). A companion paper by Barker et al. (this volume) describes mining operations and production of perlite for these three deposits. New Mexico supplies approximately 80% of perlite produced in the United States.

The most significant common aspect of perlite deposits in New Mexico is that they are all *high-silica rhyolite lavas*, which contain 75.0-77.5 wt.% SiO<sub>2</sub> when calculated on an anhydrous basis (see Table 1). The extreme viscosity of high-silica rhyolite lava favors the development of very thick glassy zones across the rapidly chilled tops and margins of the slowly extruded flows. As hydrous high-silica magma rises to the surface it typically vesiculizes, fractures and dehydrates. Thus quenched lava near the top, bottom, and toe of a recent high-silica flow consists of nearly anhydrous obsidian (Westrich et al., 1988). Permeable zones of highly fractured and micro-vesicular obsidian may then be chemically weathered (hydrated by meteoric waters) to perlite in a few million years.

This paper summarizes common genetic links for commercial perlite deposits in New Mexico (see Fig. 2). These genetic links are considered to be general geologic processes associated with the formation of most commercial perlite deposits. In spite of these similarities, we emphasize here that the maximum economic potential of a perlite deposit (tonnage of accessible glass) is largely predetermined by the *unique eruptive history* of its parental high-silica rhyolite volcano. We present a reinterpretation of the eruptive history of the No Agua Peaks volcano

and discuss its implications to the distribution of perlite ore. This reinterpretation is guided by relatively new concepts concerning the emplacement of silicic lava domes and flows (Swanson et al., 1987) and the concept of compositionally zoned high-silica rhyolite magma chambers (Hildreth, 1981). Geologic descriptions of the Socorro and Grants perlite deposits are also presented. Comparison of these three deposits shows that the glassy flat tops of microvesicular high-silica rhyolite lava flows (not domes) are the most favorable precursors of commercial perlite deposits. This paper represents a significant revision of an unpublished preprint (Chamberlin et al., 1994).

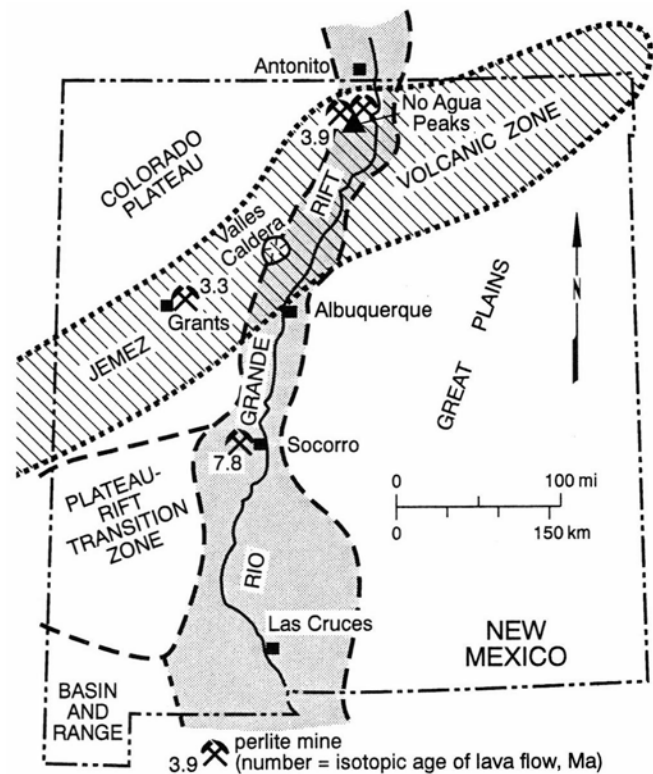

FIGURE 1—Index map of New Mexico showing the location of producing perlite deposits relative to major tectonic provinces (modified from Chapin et al., 1978; Humphreys and Dueker, 1994). Isotopic ages are from Table 1.

TABLE 1—Isotopic cooling ages of New Mexico perlite deposits.

Location/mine	Material dated	Method	Age $\pm$ 2 $\sigma$ (Ma)
No Agua/ Grefco	Obsidian	K-Ar	3.91 $\pm$ 0.27 <sup>1</sup>
Grants/ U.S. Gypsum	Obsidian	K-Ar	3.34 $\pm$ 0.16 <sup>2</sup>
Socorro/ Grefco	Sanidine	<sup>40</sup> Ar/ <sup>39</sup> Ar	7.85 $\pm$ 0.04 <sup>3</sup>

<sup>1</sup>Lipman and Mehnert, 1979<sup>2</sup>Lipman and Mehnert, 1980<sup>3</sup>New Mexico Geochronology Research Laboratory; M. Heizler and W. McIntosh, NMBMMR, written comm. 1993.

### Genetic links of perlite

The genesis of water-rich (2-5 wt.% H<sub>2</sub>O) volcanic glass, commonly called perlite, requires a long chain of complexly interacting geologic processes and events. The most fundamental and essential genetic links associated with the formation of commercial perlite deposits are listed in Figure 2. These genetic links as applied to New Mexico deposits are discussed below. Also note that several competing geologic processes tend to disrupt or curtail the formation of large bodies of nearly anhydrous volcanic glass (obsidian) capable of becoming a commercial perlite deposit. Examples of these inhibiting processes include explosive decompression (fragmentation) of rhyolitic magma or high-temperature crystallization in the slowly cooled core of a rhyolite flow.

#### Tectonic setting

Commercial perlite deposits in New Mexico are the magmatic and volcanic expression of a plate tectonic event that began approximately 30 million years ago (Ma) when western North America started to drift over part of the East Pacific Rise (Atwater, 1970). Continuing westward drift of the continent over this hot upwelling zone in the upper mantle (see Davis and others, 1993; Humphreys and Dueker, 1994) has led to increasing extension of the continental crust in middle to late Cenozoic time. Two episodes of gravitational collapse and discontinuous spreading of the continental crust have

formed the strongly extended Basin and Range province and its arm-like projection known as the Rio Grande rift. Isotopic cooling ages for commercial perlite deposits in New Mexico (Fig. 1, Table 1) indicate that these altered lavas were erupted contemporaneously with the latter episode of rifting in late Miocene to Pleistocene time.

Widespread basaltic volcanism across the western United States in late Cenozoic time (<16 Ma) is readily attributed to upwelling and partial melting of upper mantle rocks below the extensional orogen (Humphreys and Dueker, 1994). Associated loci of secondary partial melting in the lower to middle crust are likely sources of basalt-dacite-rhyolite volcanic fields such as the Taos Plateau volcanic field. The Taos field is located at the intersection of the northeast trending Jemez volcanic zone with the Rio Grande rift (Fig. 1; see Lipman and Mehnert, 1979). The Jemez volcanic zone has been a linear trend of episodic basaltic-to-rhyolitic volcanism for the past 10 million years. It is presently coaxial with a wide northeast-trending belt of low-velocity upper mantle interpreted as a zone of ongoing partial melting (Spence and Gross, 1990; Humphreys and Dueker, 1994). The Jemez volcanic zone, also known as the Jemez lineament, appears to be generally coincident with a Precambrian age-province boundary, which may define an ancient continental suture zone (Aldrich and Laughlin, 1984).

#### High-silica rhyolites

By definition, high-silica rhyolites contain 75.0-77.5 wt.% SiO<sub>2</sub>, when calculated on an anhydrous basis (Mahood and Hildreth, 1983). The most significant common trait of producing perlite deposits in New Mexico is that they are all high-silica rhyolite lavas (Table 2). On a world-wide basis, all major perlite deposits are

TABLE 2—Representative chemical analyses of samples from commercial perlite deposits in New Mexico. LOI = loss on ignition (total volatile content). Calculated anhydrous SiO<sub>2</sub> content assumes that LOI is 100% water.

Sample No.	No Agua 66L-234A <sup>1</sup>	Socorro 8-23-3 <sup>2</sup>	Socorro G-1B <sup>3</sup>	Grants U.S. Gypsum <sup>4</sup>
SiO <sub>2</sub> (wt.%)	75.97	74.35	74.99	73.53
Al <sub>2</sub> O <sub>3</sub>	13.18	12.60	12.63	12.82
Fe <sub>2</sub> O <sub>3</sub> <sup>*</sup>	0.63	0.48	0.60	0.75
MgO	0.04	0.01	0.03	0.14
CaO	0.49	0.50	0.50	0.53
Na <sub>2</sub> O	4.25	3.33	4.26	4.32
K <sub>2</sub> O	4.81	5.13	4.08	4.29
TiO <sub>2</sub>	0.06	0.05	0.05	0.03
P <sub>2</sub> O <sub>5</sub>	0.01	0.01	0.02	0.05
MnO	0.15	0.09	0.07	0.11
LOI	0.14	3.34	1.60	3.34
Total	99.75	100.01	98.83	99.91
Anhydrous				
SiO <sub>2</sub> (wt.%)	76.09	77.12	76.22	76.07
Rb (ppm)	280 <sup>5</sup>	256	267	no data
Sr	2.5 <sup>5</sup>	2	4	no data

<sup>1</sup>Obsidian from Grefco quarry at No Agua; from Lipman and Mehnert, 1979.<sup>2</sup>Perlite ore from Grefco quarry at Socorro; from Bobrow et al., 1983.<sup>3</sup>Felsite from northeast flank of Socorro perlite deposit; R. M. Chamberlin, unpublished data.<sup>4</sup>Perlite ore from U.S. Gypsum quarry at Grants; from Austin and Barker, 1995.<sup>5</sup>Trace element data from Zielinski, Lipman, and Millard, 1977.<sup>\*</sup>Total Fe as Fe<sub>2</sub>O<sub>3</sub>

FIGURE 2—Perlite's genetic links: a sequential list of fundamental and essential geologic processes associated with the formation of commercial perlite deposits. Chain diagram modified from Ohle and Bates, 1981.

apparently high-silica rhyolites (Kadey, 1983, table 2;  $>75\%$   $\text{SiO}_2$  when recalculated anhydrous).

The extreme viscosity of high-silica rhyolite lavas (Friedman and others, 1963) favors the development of thick glassy zones across the rapidly chilled tops of slowly extruded flows. Research drilling through Quaternary high-silica rhyolite lavas has documented that the upper obsidian zone may be as much as 60 m thick (Manley and Fink, 1987).

Compared to low-silica rhyolites (70-75%  $\text{SiO}_2$ , anhydrous), high-silica rhyolites are characterized by strong enrichment of highly charged cations such as Nb, Ta, U, and Rb and distinctly low abundances of Mg, Ca, Sr, and Ba. Geochemical and mineralogical studies of large volume high-silica rhyolite ash-flow tuffs (Hildreth, 1981) have led to the well documented concept of compositionally zoned magma bodies, as illustrated in Figure 3. Large volume ash-flows are emplaced in a geologic instant (days to months). Thus, the typical upward decrease in rubidium concentration observed in high-silica ash-flow sheets must record compositional zonation in the pre-eruption magma chamber. The empirical data from compositionally zoned ash-flow tuffs implies that high-silica magma chambers normally empty downward from the top (Hildreth, 1981, table 1). We suggest that the concept of compositionally zoned high-silica rhyolite magma chambers, when combined with precise trace-element distribution data, can be a valuable tool in deciphering the eruptive history of some larger perlite deposits such as at No Agua Peaks (See Table 3). The total volume of high-silica lava extruded at No Agua Peaks was approximately  $0.82 \text{ km}^3$  (Table 4). **If the strong**

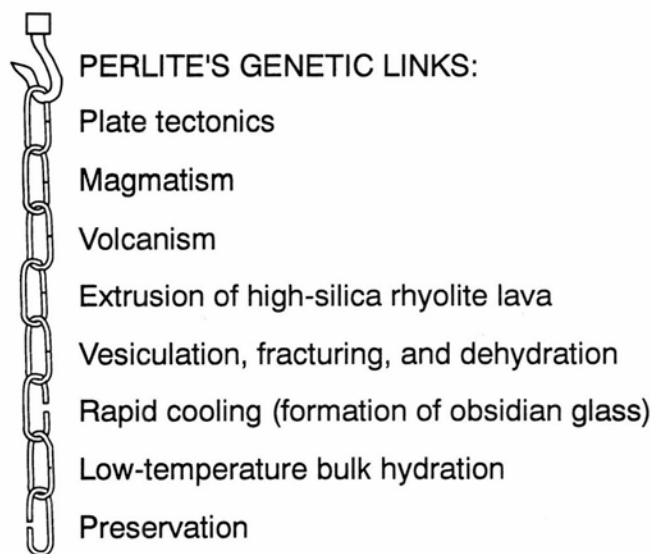
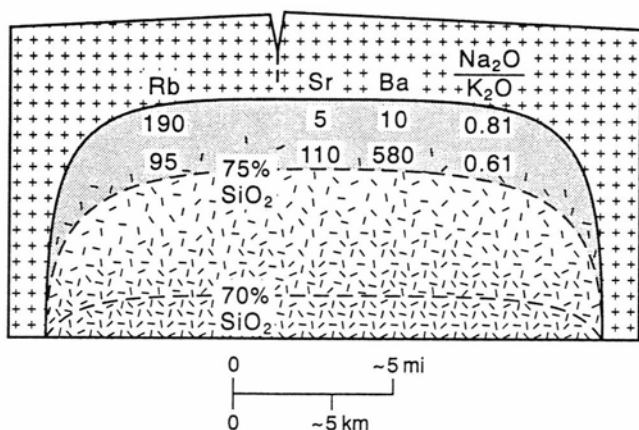

FIGURE 3—Conceptual model of a compositionally zoned magma chamber (in cross section, modified from Hildreth, 1981, fig. 10). Vertical zonation of trace-element concentrations (ppm) and  $\text{Na}_2\text{O}/\text{K}_2\text{O}$  ratio in the high-silica rhyolite magma (shaded) are from (Hildreth, 1981, table 1, Bishop Tuff). Dashes illustrate the distribution of pre-eruption phenocrysts, which typically increase downwards with decreasing silica content.

compositional variation at No Agua truly represents a zoned magma chamber, then the volume of that chamber must have been relatively small in order to allow that zonation to appear in the surface extrusions.

### Geometry and zonation of lava domes and flows

The economic potential of a perlite deposit is predetermined by the eruptive history of its parent volcano. New insights concerning the emplacement of silicic lava domes and flows have been derived from careful long-term observations (1981-1983) of a viscous dacite lava dome, which was slowly and episodically extruded onto the floor of the May 18, 1980, crater of Mount St. Helens (Swanson et al., 1987). Swanson's description emphasizes that the Mount St. Helens lava dome initially grew by numerous month-long periods of endogenous inflation each of which was followed by days-long periods of exogenous surface extrusion of stubby lava flows. As the pile of interleaved short flows grew around the vent, endogenous growth became increasingly important and finally the style changed from episodic to essentially continuous endogenous and exogenous growth. Swanson and his colleagues believe: "...the dome, its feeding conduit, and its magma reservoir to be in a delicate balance, able to alternate over short periods of time between dominantly endogenous and exogenous growth and between dominantly explosive and effusive activity." These new insights indicate that large steep-sided lava domes are most likely to be composite structures that contain complex internal cooling zones, very different from the simple "endogenous dome" model suggested for the No Agua Peaks perlite deposit (e.g., Whitson, 1982, fig. 2; Breese and Piper, 1985).

Our understanding of the geometry and internal zonation high-silica rhyolite lava flows and domes, as derived from a limited review of recent literature, is summarized in Figures 4 and 5. Key sources include the work of Swanson et al., (1987) as described above, and the results of research drilling through geologically young high-silica flows at Inyo domes, California, and at the Valles caldera in northern New Mexico (Fink and Manley, 1987; Westrich et al., 1988). Other useful descriptions and images of high-silica dome-flow complexes are found in Loney (1968), Smith et al., (1970), and Green and Short (1971). Our morphological comparison of eight separate high-silica dome-flow centers that define the Valles caldera ring-fracture zone (Smith et al., 1970; Spell et al., 1993) allows a gross estimate of the relative frequency of high-silica domes to high-silica flows.

The following general characteristics of high-silica rhyolite domes and flows are derived from the above literature and illustrated in Figures 4 and 5:

1. Initial eruptions from high-silica rhyolite volcanoes are commonly explosive "throat-clearing" events characterized by development of a large

TABLE 3—Geochemical fingerprints of obsidian samples for each major topographic location. Data from Whitson, 1982; Lipman and Mehnert, 1979. Assignment of eruptive phase is based on vertical zonation and emptied downwards from the top (see Figures 3, 7, and 8). A horizontal line indicates a significant demarcation, significantly greater than analytical error, between the low-Rb late phase and the high-Rb early phase.

Location	Phase	Rb (ppm)	$\text{Na}_2\text{O}/\text{K}_2\text{O}$
West peak	Early	318	1.03
Low hills	Middle (?)	280	0.88
South peak	Late	155	0.81
North peak	Late	140	0.70
East peak	Late	135	0.74

TABLE 4—Eruptive unit geometry and relative resource potential for New Mexico commercial perlite deposits. Maximum resource (Mt = millions of metric tons) assumes all original glass (obsidian) is altered to perlite and none has been removed by erosion. Proportion of "original glass" in No Agua eruptive units estimated from cross section (Fig. 9). Inaccessible glass that lies below crystalline felsite zones (e.g., noncommercial glass) is not included in the estimate of "original glass." Thickness and volume estimates use rough conversion factor of 100 ft = 30 m. Assumed nominal density of perlite is 2.2 gm/cc or 2.2 mt/m<sup>3</sup>.

Eruptive unit	Geometry	Thickness (m)	Volume (km <sup>3</sup> )	Original glass (%)	Maximum resource (±30%) (Mt)
No Agua:					
West peak (E)	Large dome	270	0.30	2–5	33
Low hills (M)	Thin flows	75	0.17	40–50	187
East peak (L)	Thick flows	120	0.35	15–20	154
Socorro	Small dome	90–120	0.03	90–95	63
Grants	Large dome	210	0.25	2–5	28

E = early phase M = middle(?) phase L = late phase (see Figures 8 and 9)

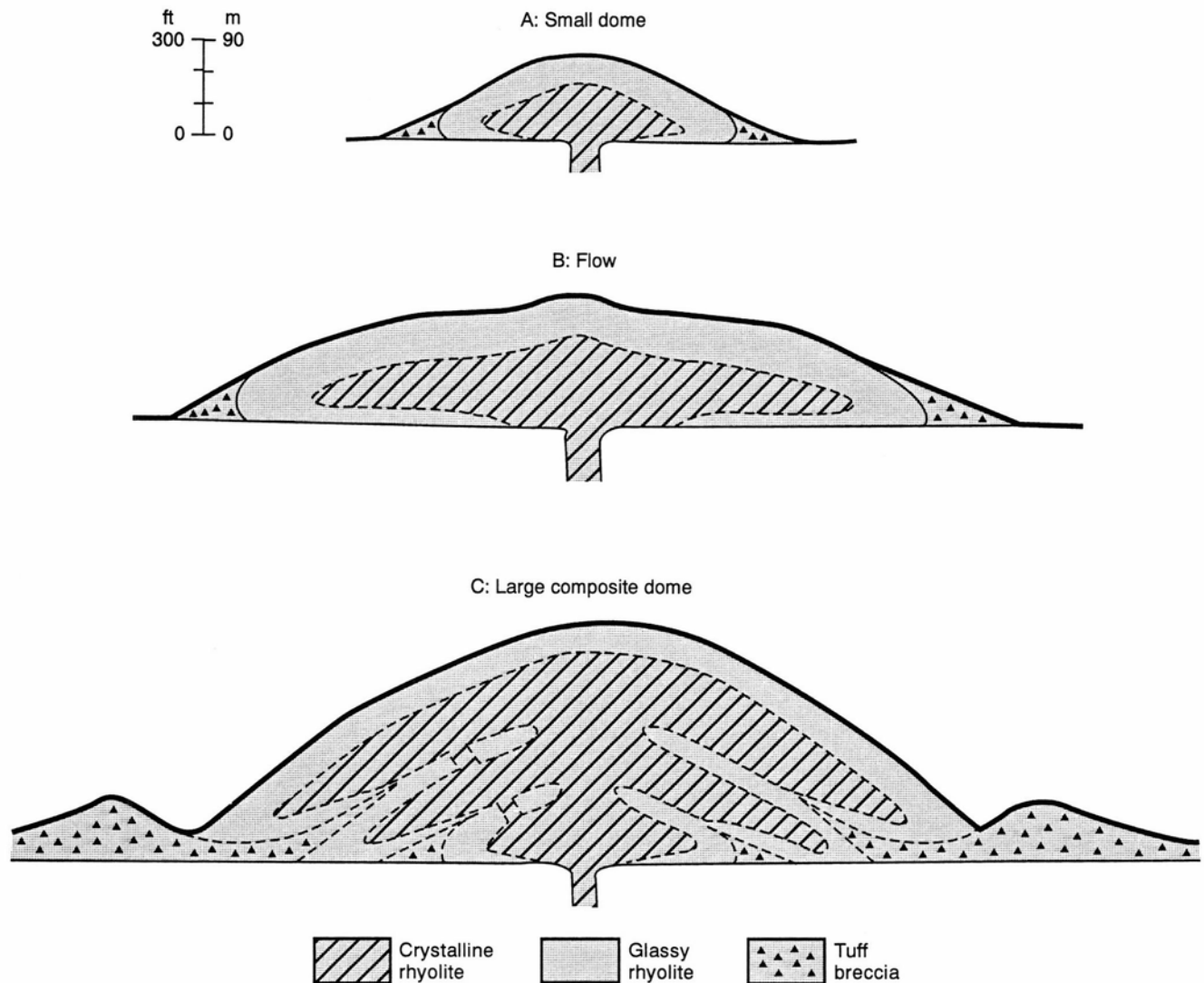

FIGURE 4—Schematic cross sections illustrating the geometry and internal cooling structure of a small dome **A**, a flow **B**, and a large composite dome **C**; the latter consisting of overlapping flow lobes. Small dome and flow are simple cooling units modeled after Manley and Fink, 1987. Second-order folds commonly observed on the upper surface of young flows (e.g., Green and Short, 1971, plate 90 B) are not shown. Composite dome is modeled after observations of the 1981–1983 lava dome at Mt. St. Helens (Swanson et al., 1987).

- tephra ring (ash and pumice-rich tuff breccia) surrounding the vent (Westrich et al., 1988).
- Steep-sided domes commonly range from 90 m to 360 m in height and have aspect ratios (width:height) of approximately 5:1 to 8:1
- Flat-topped flows tend to be lobate and short, less than 2 km long (except on steep slopes), with aspect ratios of 10:1 to 20:1.
- The steep toes of flows are commonly 90 m high, which is considered to be an average thickness for the very viscous flows.
- A small endogenous dome (Fig. 4A) may evolve

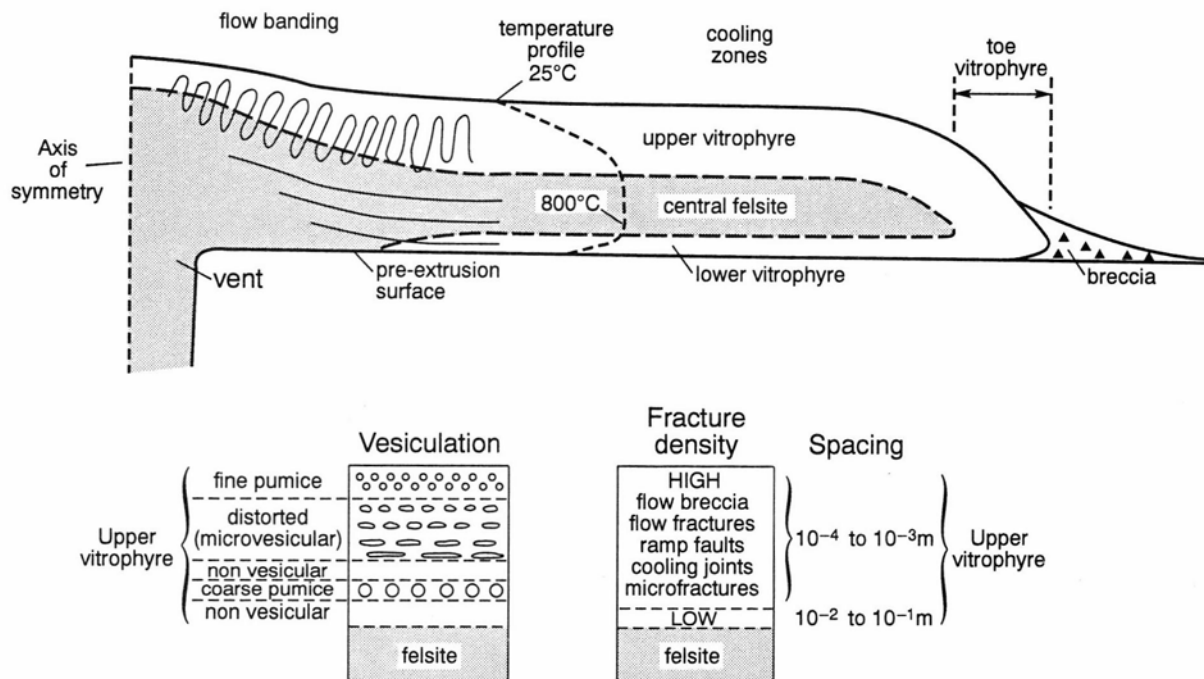

FIGURE 5—Schematic cross section illustrating the primary lithologic and textural zonation of a rhyolite lava flow; based on a simple cooling unit model (modified from Christiansen and Lipman, 1966; Fink and Manley, 1987; Manley and Fink, 1987). Vesicle size in pumiceous zones is highly exaggerated for clarity. Coarsely vesicular pumice zones are distinctly enriched in magmatic water (0.5 wt.%) in comparison to adjacent obsidian that contains about 0.1 wt.% magmatic water (Fink and Manley, 1987). Approximate height (thickness) of flow is 90 m.

6. Large domes, 180 to 360 m high (Fig. 4C) are most likely composite structures, consisting of interleaved, steeply inclined, stubby flows stacked up adjacent to their primary vent (Swanson et al., 1987).
7. Vents for domes and flows directly underlie the topographically highest point on the structure.
8. Rock-avalanche breccias and blocky pumiceous-ash deposits commonly form tephra rings around composite domes (Fig. 4C).
9. Singular composite domes are about three times more common than composite domes with flows emanating from their flanks, and about seven times more common than singular flows or small domes (Smith et al., 1970).
10. Flow bands tend to be steeply inclined in the upper half of flows and gently inclined in the lower half (Fig. 5 top).
11. Chilled vitrophyre zones typically parallel upper and lower cooling surfaces and merge at the steep toe of the flow (Fig. 5 top).
12. Pumiceous tops of flows generally grade downward to flattened microvesicular zones and dense non-vesicular glass, a reflection of the balance between vapor pressure and increasing overburden pressure (Fig. 5 bottom).
13. Pumiceous and non-pumiceous bands may be complexly interlayered and folded, a relationship that presumably reflects non-uniform vapor pressure in the viscous lava.
14. Coarsely vesicular zones (Fig. 5 bottom) represent redistribution and concentration of magmatic water (as much as 0.5 wt.% H<sub>2</sub>O) within the active flow.

15. Fracture density and interconnected vesicles (primary permeability) generally decrease downward in the flow (Fig. 5 bottom).
16. Primary fractures become widely spaced just above the mobile core of the flow; the core typically crystallizes to spherulitic felsite.

#### Hydration

Low-temperature hydration of obsidian by meteoric water is demonstrated to be a viable geologic process by two compelling lines of evidence. First, for over 30 years archaeologists have successfully used the thickness of hydration rinds on obsidian artifacts as an accurate dating tool (Friedman and Trembour, 1978). Second, oxygen and hydrogen isotope ratios of water extracted from 12 perlite samples collected in the western United States clearly show a meteoric origin (Taylor, 1968). Thus we confidently reaffirm the statement by Kadey (1983) that "Now there is universal acceptance of the theory that perlite was formed by the secondary hydration of obsidian after its emplacement." Alkali-rich obsidian is hygroscopic, thus its alteration to perlite by the slow diffusion of meteoric water inward from a wetted surface is virtually inevitable. The most significant factor in the *bulk* hydration of a large mass of obsidian to form a commercial perlite deposit is not composition, temperature, or time, but rather the primary distribution and spacing of wettable surfaces within the body of glass (Friedman et al., 1966; Friedman and Long, 1976; Friedman and Smith, 1958).

Classic "onionskin" perlite is formed by the hydration of subequant fragments of obsidian. Progressive inward diffusion of water causes the shell-like hydration rind to expand and create a strong tensile stress at the diffusion boundary. As the rind thickens, tension increases and ultimately forms a fracture that propagates

concentrically along the diffusion boundary. This tension fracture then becomes a new diffusion front and the process repeats itself ad infinitum. Granite boulders of exfoliation are kindred to classic perlite. Using the hydration rate calculated by Friedman et al., (1966, p. 327), a fist-sized (15 cm) block of solid obsidian requires approximately 100 million years to hydrate completely to classical perlite.

New Mexico perlite deposits have only had a few million years to become uniformly hydrated in bulk (Table 1). Obviously, the primary fracture spacing (and spacing of interconnected microvesicles) in the obsidian zones must have been much less than 15 cm, perhaps more like 0.5-1.0 mm, in order to achieve the observed uniform degree of hydration in the apparent time span.

We regard the formation of New Mexico perlite deposits as a type of chemical weathering. It is characterized by leaching of sodium and other mobile elements (e.g., Cl and F) and slight enrichment of potassium (compare perlite and unaltered felsite from Socorro in Table 2). Chemical weathering by meteoric waters may occur at the earth's surface, and for some distance below the surface. In the latter case leaching by shallow ground water is regarded as a continuum with subaerial weathering.

Some authors continue to suggest that high-temperature hydration of silica-rich lava prior to or during its emplacement may be a viable process in the formation of perlite (e.g. Breese and Barker, 1994; Breese and Piper, 1985; Weber and Austin, 1982). Granular perlite ores have been considered as possible candidates for a high-temperature hydration origin because they typically lack classic onionskin textures and macroscopic nodules of obsidian (Weber and Austin, 1982). Granular perlite ores are characterized by highly flattened microvesicles (Kadey, 1983; Breese and Barker, 1994). Our observation of micronodules of obsidian (0.1-0.2 mm in diameter) in granular perlite ore from the Socorro deposit implies that its precursor was a chilled microvesicular obsidian. In thin section, Socorro perlite ore displays flattened microvesicles approximately 0.5-1.0 mm long separated by small plate-like masses of glass about 0.1-0.3 mm thick. We suggest that the plate-like geometry of wettable surfaces in a flattened microvesicular obsidian inhibits the development of classic onionskin fractures. Non-classical, granular perlite ores are therefore readily interpreted as the product of low-temperature hydration of microvesicular obsidian.

### Preservation

At the same time that large obsidian deposits are being weathered (hydrated) to perlite, competing geologic processes tend to destroy the deposits or make them inaccessible to open-pit mining. These destructive processes include erosion, burial by younger volcanic rocks or sedimentary deposits, dismemberment by faulting, and hydrothermal alteration. The latter is commonly associated with devitrification (post-cooling crystallization).

High-silica rhyolite flows are characteristically emplaced in active tectonic belts; thus the above-mentioned tectonically influenced destructive processes are common aspects of perlite deposits and surrounding terranes. We note that the No Agua volcano was emplaced in a favorable structural zone at the western edge of the east-tilted San Luis Basin (see Lipman and Mehnert, 1979, fig. 2). If it had been located near the east margin of the basin, then the No Agua volcano would

now be buried by younger strata; and if located further west, then it would now be deeply eroded.

Some geologists consider volcanic glass to be "metastable" and infer that obsidian will inherently crystallize (devitrify, after cooling) given a few million, or tens of millions of years. On the cold dry surface of the moon volcanic glasses and impact glasses have persisted for over 4 billion years (Carmichael, 1979). This single observation should put the notion of "inherent devitrification" to rest. Although rare, occurrences of volcanic glass on the earth are known to be as much as 300-600 million years old (Marshall, 1961; R. L. Smith, U.S. Geological Survey, pers. comm. 1985).

### No Agua Peaks perlite deposit

The No Agua Peaks perlite deposit in north-central New Mexico (Fig. 1) is the world's largest perlite deposit (Whitson, 1982). Mining operations of Dicapperl are on the west flank of the volcanic center and operations of Harborlite Corporation are located on the east flank of the volcano. The No Agua Peaks represent one of the older volcanic centers that collectively make up the Taos Plateau volcanic field, which was erupted between about 4.5 and 2.0 million years ago (Lipman and Mehnert, 1979). Lipman and Mehnert (1979) report a K—Ar age for obsidian from the Grefco pit (west flank of volcano) of  $3.91 \pm 0.27$  Ma. Whitson (1982) cites an isotopic age of 4.2 Ma, for which the analytical error and sample location are not given. Considering analytical error in the K—Ar method, Whitson's cited age is essentially the same as that reported by Lipman and Mehnert (1979).

The No Agua Peaks perlite deposit has been used by several authors (Whitson, 1982; Kadey, 1983; Breese, 1984; Breese and Piper, 1985) as a model for the genesis of commercial perlite deposits. The detailed No Agua model of Breese and Piper (1985) has two well-established aspects: (1) perlite is primarily formed by the low-temperature diffusion of meteoric water into nearly anhydrous obsidian, and (2) the precursor obsidian is formed by rapid chilling of the top, bottom, and margins of a steep-sided, tabular body of rhyolite lava. An additional component of this *simple cooling unit model* is that the slowly cooled core of the thick tabular body commonly crystallizes to form a noncommercial lithoidal rhyolite, often called felsite or spherulitic rhyolite (Christiansen and Lipman, 1966; Manley and Fink, 1987).

### Relative age of eruption

Lavas and minor breccias that comprise the No Agua Peaks are phenocryst-poor (<1%) high-silica rhyolites (Table 2; Whitson, 1982, table 1). Previous investigations (Naert, 1974; Naert et al., 1980; Whitson, 1982) all recognized that the high-silica lavas on the east flank of the volcanic center were relatively enriched in Ba and Sr, and depleted in Rb, in comparison to Ba/Sr-poor and Rb-rich lavas that comprise the western flank and central portion of the volcanic pile (Whitson, 1982, figs. 10 and 11).

For the purpose of the following discussion, we choose to refer to these geochemically distinct lavas simply as Rb-rich, in the western domain, and Rb-poor in the eastern domain (Fig. 6). Based on statistical analysis of multi-element chemical data from 72 samples, Naert et al., (1980, p. 27) observed that the Rb-poor lavas were "less differentiated" and contained slightly higher mean concentrations of Fe, Mg, Ca, and K and lower mean con-



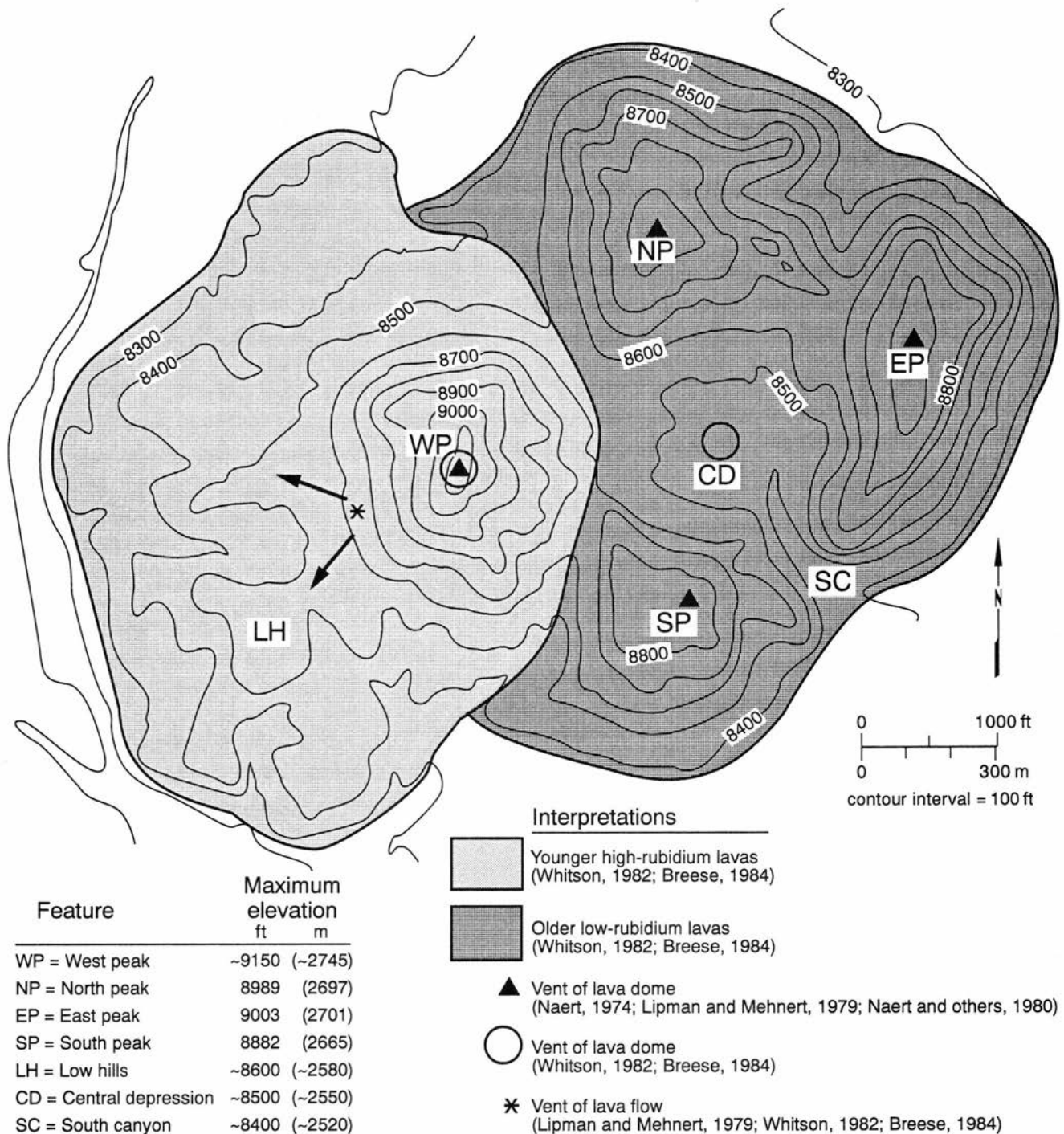

FIGURE 6—Generalized topographic map of the No Agua Peaks volcanic center showing major topographic features, published interpretations of age relationships of compositional domains, and published interpretations of volcanic vent locations. Contour interval in hundred feet above mean sea level. To make approximate conversion of feet to meters multiply by 0.3.

centrations of Na and Mn than the Rb-rich lavas. Using a classic concept of progressively differentiating magma chambers (Bowen, 1928), Naert then presumed that if the No Agua lavas were erupted from a single magma chamber, then the "less differentiated" Rb-poor lavas of the eastern domain should have been emplaced before the "more differentiated" Rb-rich lavas of the western domain. Whitson (1982, p. 93) preferred to interpret the Rb-poor and Rb-rich lavas as "derived from two compositionally different magma sources," presumably meaning two different magma chambers. Whitson also inter-

preted the Rb-poor lavas as being older; and in cross section he showed the eroded flank of a Rb-poor lava dome as being unconformably overlapped by a Rb-rich lava dome, whose vent is centered under west peak (Whitson, 1982, fig. 13).

At this writing we do not know of any critical field relationships, either superposition or cross-cutting, which can be used to establish the relative ages of the Rb-poor and the Rb-rich lavas. However, the well-established empirical observations of compositionally zoned ash-flow tuffs and the derivative concept of composi-



tionally zoned magma chambers (Fig. 3) indicates to us that there is a better than even chance that the Rb-rich and Rb-poor lavas represent early and late phase lavas, respectively, that were extruded from a single compositionally zoned magma chamber.

Geochemical fingerprints of lavas from different morphological units of the No Agua volcanic center, and our inferred relative age assignment are listed in Table 3. We tentatively subdivide the Rb-rich lavas into an early and middle(?) phase of eruption (Table 3) on the basis of slightly different Rb concentrations (nominal error  $\pm 10\%$ ) and  $\text{Na}_2\text{O}/\text{K}_2\text{O}$  (nominal error  $\pm 25\%$ ). Sr and Ba concentrations (Table 3, Fig. 3) argue for the opposite relative age relationship, but these concentrations are near detection limit where analytical error is typically  $\pm 50$  to  $\pm 100\%$ . Thus the real trend for Ba and Sr may be lost in analytical noise.

### Morphology of the No Agua volcano

The present day morphology and major topographic features of the No Agua volcanic center are shown in Figure 6. Glassy zones mantle all the peaks and low hills (Whitson, 1982, fig. 12); thus, it appears that the original volcano has been only moderately modified by erosion over the last 3.9 million years. If so, then erosion has preferentially removed loose breccia and ash leaving the "harder" lava as bedrock. The outer margins of the volcano are defined by steep slopes that rise 75-150 m above the surrounding basaltic plain. Presumably these glassy, steep slopes represent the moderately eroded toes of the original lava flows.

The highest peak, west peak, rises 240-270 m above the adjacent plain. All previous investigators have interpreted this round, steep-sided peak as a lava dome underlain by a central conduit (Lipman and Mehnert, 1979, fig. 1; Whitson, 1982, fig. 13). We emphatically agree, and furthermore suggest that this apex overlies the primary conduit for the entire volcano. The low hills area (Fig. 6) has been recognized by most authors as short coulee lava flows emanating from the west flank of west peak. We also support this interpretation.

Differences of opinion, however, exist with regard to the source vent or vents for the eastern three peaks (north peak, east peak, and south peak, Fig. 6). Naert (1974) and Lipman and Mehnert (1979) inferred a vent under the crest of each steep-sided peak. Whitson (1982) suggests that these three peaks are the expression of a large endogenous dome whose vent now underlies the cen-

tral depression (Fig. 6). Whether four domes or two domes, both models appear to have significant inconsistencies that reduce their viability.

### Four-dome model

The four-dome (four-vent) model (see Fig. 6; Naert, 1974, Lipman and Mehnert, 1979) has at least two severe inconsistencies. The most significant problem is that the inner flanks of north peak and east peak are formed by a continuous outcrop of crystalline rhyolite approximately 60-90 m thick (Naert, 1974, plate 1; Whitson, 1982, fig. 12). Obviously these peaks must represent a single cooling unit extruded penecontemporaneously from the same source, and cannot represent two abutting lava domes. Also, no apparent theoretical reason exists to explain why three of the proposed vents were sources of low-Rb lava, while the fourth vent (west peak) was the source of a high-Rb lava.

### Two-dome model

The two-dome (two-vent) model of Whitson (1982) and Breese (1984) clearly allows the compositionally distinct high-Rb lavas to be erupted from a vent under west peak, and would seem to allow the low-Rb lavas to be erupted from another vent under the central depression (Fig. 6). Whitson interpreted the low-Rb lavas as a large endogenous lava dome whose west flank was truncated and then unconformably overlain by the smaller lava dome of west peak (Whitson, 1982, fig. 13). We have redrawn Whitson's 1982 cross section (west to east) in a south-to-north orientation and present it here as Figure 7. This present-day true-scale cross section seems to show the aspect ratio (height:width) of a flat-topped lava flow (or flows) and does not look like a steep-sided lava dome to us. This cross section also illustrates that the formation of the central depression requires a large part of the "hard" crystalline core of the proposed dome to be removed by erosion; a scenario that we think is unlikely. Map relationships at the deep penetrating south canyon (Fig. 6) suggest to us that the canyon has incised along the abutting toes of two steep-sided flows (east peak and south peak). Whitson's geologic map (Whitson, 1982, fig. 12) shows that only a thin horizontal felsite zone is present along the walls of this canyon. If this canyon truly cuts perpendicular to Whitson's dome margin then the felsite zone should thicken very rapidly upstream along the canyon. The observed felsite pattern does not seem to support the large endogenous dome

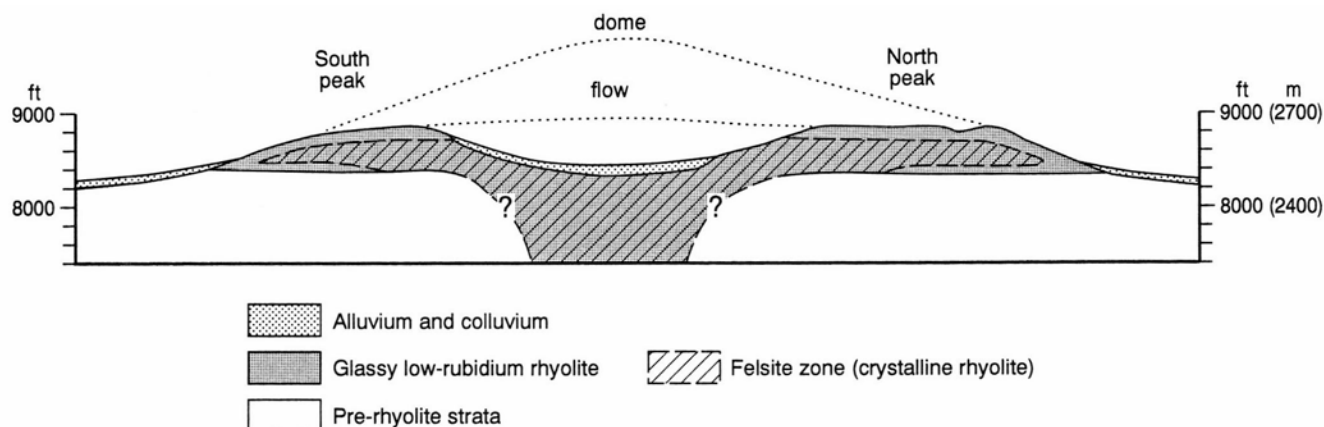

FIGURE 7—Present-day north-south cross section illustrating Whitson's 1982 interpretation of a "large endogenous dome" for the three eastern peaks of the No Agua volcanic center. Cross section derived from Whitson, 1982 (figs. 11 and 12).

hypothesis. Also it is difficult to explain why this canyon would have cut so deeply into the presumably solid margin of the large exogenous dome proposed by Whitson.

### One-dome model

Our preferred one-dome, (one-vent) eruptive model for the No Agua volcano is shown in map view and cross section in Figures 8 and 9, respectively. These palinspastic diagrams show the inferred pre-erosion, pre-faulting geometry of the No Agua volcano shortly after it cooled to ambient temperature, approximately 3.8 Ma ago.

In order of formation, the major elements of the one-dome model are:

1. Initial "throat clearing" explosive eruptions produced a large Rb-rich tephra ring around the vent. Presumably this tuff—breccia deposit was thickest and highest on the downwind eastern side of the vent. Rapid vesiculation and degassing of the magma remaining in the conduit chilled the upper part of the magma column. Thus, early phase high-Rb lavas extruded from the vent were extremely viscous and tended to pile up over the vent and within the ring of initial tuff breccia.
2. A high-Rb, high-silica, composite lava dome, as much as 270 m high, was slowly extruded over the primary vent at west peak.
3. As the composite dome grew its weight acted as a stopper over the underlying magma conduit and chamber; this allowed vapor pressure to increase within the magma column and the magma to re-equilibrate to a nominal pre-eruption temperature of 900°C (Friedman et al., 1963, fig. 11).
4. As vapor pressure grew and exceeded lithostatic load, a relatively low viscosity (hotter) high-Rb, high-silica magma was relatively rapidly squeezed out from under the west flank of the composite dome.
5. Extrusion of the hotter and slightly vapor enriched (0.3 wt.% H<sub>2</sub>O) magma onto the land surface (under atmospheric pressure) produced a rapidly vesiculating (foamy) and relatively thin (75 m) lava flow that spread in a semicircular geometry as much as 1.3 km outward from the vent. Apparently an obstruction caused the flow to divide into two lobes.
6. Rapid cooling of the upper surface of the lava flow by gas expansion, gas escape, and conduction led to the formation of an upper foamy obsidian zone as much as 45 m thick. Small ash-flows and debris-flows may also have accompanied this middle phase of eruption.
7. Presumably following another period of quiescence and vapor pressure increase, the northeast flank of the composite dome was fractured by radial expansion, and a new lateral vent was created for the high-silica volcano.
8. This relatively unconstrained radial vent allowed rapid degassing of the magma, possibly by small ash-flow events. Late phase low-Rb high-silica lavas were then slowly extruded from the radial dike and bulldozed their way eastward through and around a large pile of tuff breccia related to the early dome building event. The 120-150 m thickness of the low-Rb lava flow lobes indicates

a substantially higher bulk viscosity for the late phase lavas in comparison to the middle phase lavas (Fig. 9).

9. Finally, the late phase viscous flow lobes nearly encircled the older tuff-breccias to form a large kipuka, a Hawaiian term for openings of older rock encircled by younger lava flows (Green and Short, 1971).

The difference in thickness (i.e. bulk viscosity) between middle- and late-phase lavas is primarily attributed to a higher eruption temperature for the middle-phase lava. Increased concentrations of fluorine also tend to reduce the viscosity of high-silica magmas, but no data are available at this time to evaluate this potential variable.

The model of a singular composite dome flanked by lateral flows generally satisfies the inconsistencies previously described for the four-dome and two-dome models. Notably, the one dome model allows the central depression (Fig. 6) to be readily formed by preferential erosion of soft tuff breccias from the kipuka. It provides new insights concerning the original distribution of obsidian, as shown in two dimensions in Figure 9. The relative resource potentials (estimated original tonnage of accessible obsidian) for various eruptive units of the No Agua volcano are listed in Table 4. Even with cumulative errors of as much as 30% in these estimates, it seems clear that the flat tops of vesicular high-silica rhyolite lava flows are the most favorable precursor of perlite deposits. In contrast, large composite lava domes of high-silica rhyolite, which are more common, will typically yield only moderate quantities of commercial perlite.

### No Agua fault

Two lines of evidence suggest that a down-to-the-west normal fault now cuts across the No Agua Peaks volcano (Fig. 8). Naert (1974) reported a 330 m deep drill hole near the north margin of the volcano. This drill hole indicates that the base of the glassy rhyolite lava flow, now perlite (Naert, 1974), rests depositionally on a basalt lava at an elevation of about 2,400 m. This is approximately 60120 m lower than the base of the steep slopes that define the lava perimeter at other locations (Fig. 8). Additional evidence of a fault consists of north-trending, west-facing linear escarpments that define the west margins of south peak, north peak, and a low escarpment (-10 m high) in younger basalt flows about 1.6 km to the north. We suggest the depressed perlite/basalt contact in the above mentioned drill hole is on the down-dropped western side of a Pliocene to Quaternary normal fault with a stratigraphic throw of 60-120 m.

### Socorro perlite deposit

The Socorro perlite deposit, mined by Dicaperl, is about 6 km southwest of the town of Socorro in central New Mexico (Fig. 1). This small volume, high-yield deposit lies along a Quaternary fault-line escarpment that defines the eastern flank of the west-tilted Socorro Peak uplift. Our following description of the Socorro perlite is primarily based on a geologic map of the Socorro Peak volcanic center (scale 1:12,000) by Chamberlin (1980), unpublished petrologic studies by Chamberlin, a regional geochemical study of late Miocene silicic domes and flows by Bobrow et al., (1983), and drill hole data provided by Dicaperl. Except for some structural details and age relationships, our observations are in general agreement with an early reconnaissance study by We-

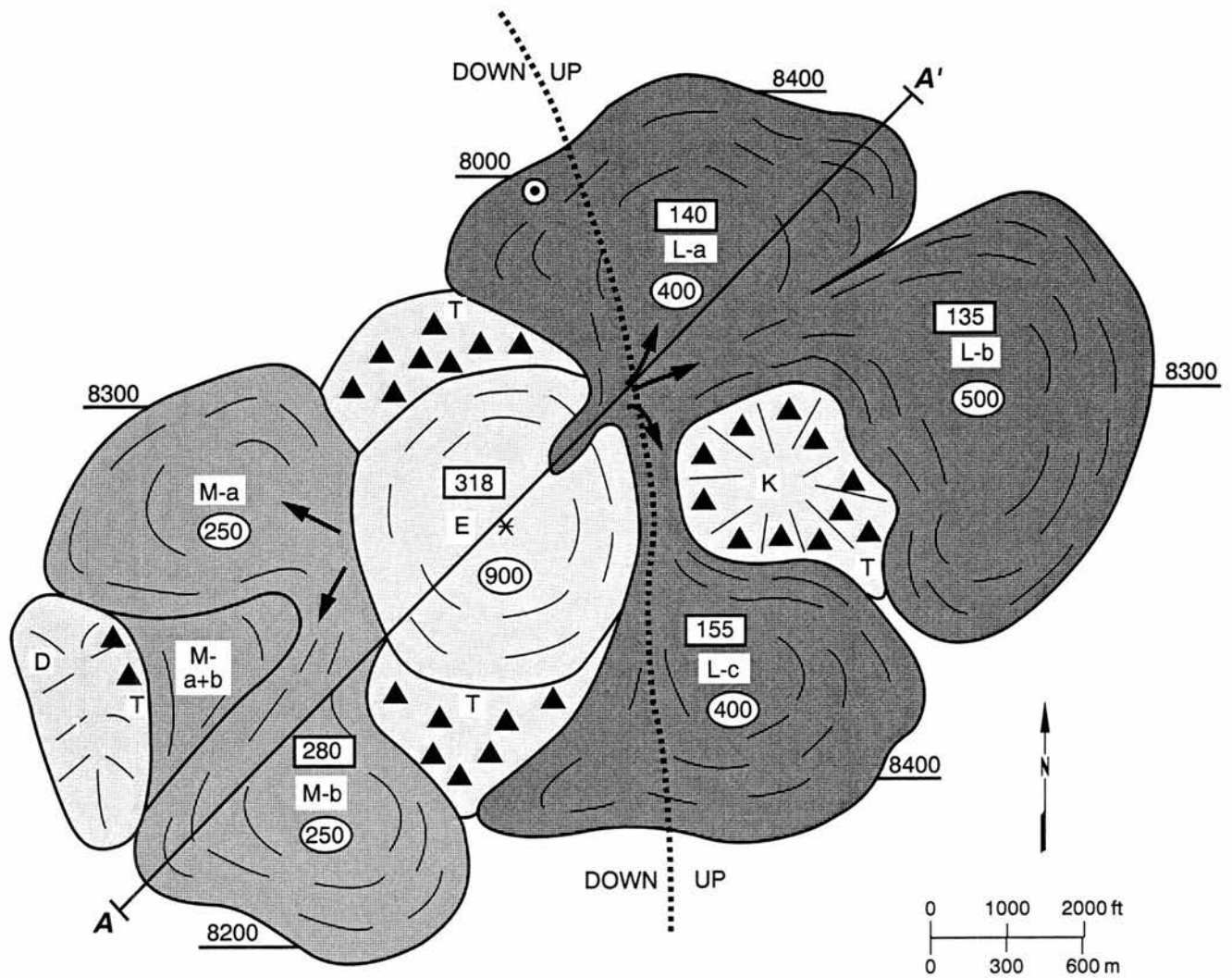

### Phases of eruption

- L = Late phase lava
- M = Middle phase lava
- E = Early phase lava
- Early (?) tuff breccia (remnant of tuff ring ?)
- 318 Rubidium concentration (ppm) in obsidian nodules (from Whitson, 1982)
- 8400 Approximate elevation (present-day) of base of lava flow (feet above sea level)
- 900 Maximum thickness of lava flow/ dome (in feet)
- Drill hole (Naert, 1974)
- ✱ Primary vent

- Inferred divergent flow at secondary lateral vent
- Generalized flow lines (after Naert, 1974)
- Kipuka or steptoe (pre-existing topographic high, flanked by younger lava)
- D = Debris-flow deposit
- T = Known exposure of tuff breccia below flank of lava flow

FIGURE 8—Line drawing of the No Agua Peaks volcanic center (ca 3.8 Ma) showing an inferred eruptive history based on rubidium distribution within the high-silica rhyolite lavas (rubidium data from Whitson, 1982). Thickness of flows and basal elevations of flows estimated from U.S. Geological Survey topographic maps. Generalized flow lines are derived from foliation data of Naert (1974). Vent locations and flow geometry are primarily guided by topography and felsite distribution (Naert, 1974, plate 1; Whitson, 1982, figs. 11 and 12). To convert meters to feet divide by 0.3.

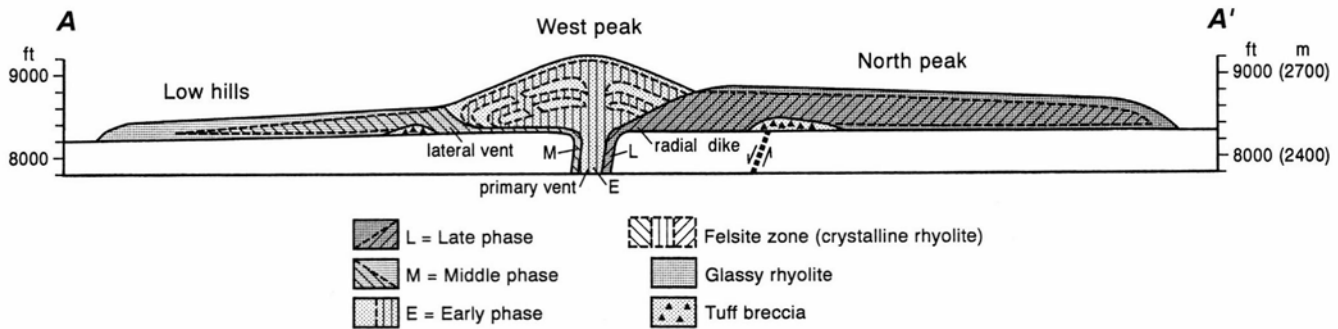

FIGURE 9—Interpretive cross section (line A–A' of Fig. 8) illustrating the primary and secondary vent geometries for early, middle, and late phases of lava extrusion at the No Agua Peaks volcanic center. Topographic profile is similar to modern profile, but smoothed to compensate for erosion. Represents zonation after complete cooling of lava flows at about 3.8 Ma. Only the first-order distribution of glass and felsite are shown; pre-eruption phenocrysts (<1%) and irregularly distributed strings of syneruptive crystalline mush (e.g. Whitson, 1982, fig. 6 and 7) are not shown. Vertical scale equals horizontal scale.

ber (1963). The overall geometry of the Socorro perlite deposit, as described below, suggests that it is transitional between a small dome and a small flow (see Fig. 4A and 4B). For brevity it is simply referred to here as a small dome.

Some unique aspects of the Socorro perlite deposit have generated different opinions regarding its origin. The general absence of classic onionskin textures and absence of macroscopic obsidian in the granular (microvesicular) perlite ore at Socorro led Weber and Austin (1982) to suggest that these granular ores were formed by high-temperature hydration of silica-rich magma prior to or during its emplacement. Alternatively we suggest that the platy geometry of wetted surfaces in the microvesicular glass inhibits the formation of classic onionskin perlite, which requires a roughly spherical hydration geometry in order to form concentric fractures. Our observation of obsidian micro-nodules in the Socorro perlite deposit support its interpretation as the product of low-temperature hydration of a permeable microvesicular body of obsidian.

The Socorro perlite deposit is interpreted here as a zone of weathering (hydration) developed on a small glassy lava dome of high-silica rhyolite (Table 2), which has recently yielded a  $^{40}\text{Ar}/^{39}\text{Ar}$  age of  $7.85 \pm 0.04$  Ma (Table 1). This new age determination, from a separate of sanidine phenocrysts, is in good agreement with an earlier K–Ar whole-rock age of  $7.4 \pm 0.4$  Ma (Chamberlin, 1980; unpubl. data from C. E. Chapin, New Mexico Bureau of Mines and Mineral Resources).

The Socorro perlite deposit represents the youngest and most silicic of a series of dacite, low-silica rhyolite and high-silica rhyolite lavas, domes and tuffs that erupted onto the playa floor of an early rift basin from about 11.9 to 7.8 Ma (Chamberlin, 1981; Table 1). Continuing sedimentation completely buried the high-silica dome by about 4 Ma. Fortunately the small dome was then uplifted along a Quaternary fault zone and sufficiently exhumed by erosion to allow open-pit mining of this now uniformly hydrated microvesicular glass.

Geologic mapping, preliminary petrographic studies, and geochemical analyses of the Socorro perlite deposit indicate the following characteristics:

1. The lava dome has a maximum lateral extent of 840 m and is exposed over a topographic interval of 135 m; the partially buried crest of the dome (or flow) is a flat surface over a distance of 360 m.
2. The lava is a high-silica rhyolite (76–77%  $\text{SiO}_2$ ,

anhydrous), strongly enriched in lithophile trace elements, namely Rb, Mn, Nb, Ta, Pb, Th, U, and heavy-rare-earth elements; also it is relatively depleted in Sr and Ba (Bobrow et al., 1983; Table 2).

3. Steep flanks of the original dome are largely buried by younger sandstones and mudstones of the lower Santa Fe Group and the southeast margin of the dome is a fault contact. Map relationships also suggest that the main perlite outcrop is split in half (east and west) by a down-to-the-east normal fault with an approximate throw of 60 m.
4. Topographic relief in the western block and a recent geophysical test hole near the south end of the eastern block both require a minimum thickness of 90 m for the original unfaulted lava dome.
5. An early phase of cogenetic lithic-rich ash-flow tuff and bedded tuffs, as much as 20 m thick, is discontinuously exposed around the flanks of the lava dome; large mudstone clasts (>0.6 m) in an ash-flow outcrop about 0.8 km north of the dome indicate proximity to the source vent.
6. Greater than 95% of the exposed lava dome consists of phenocryst-poor (<1%) glassy, micro-vesicular, flow-banded rhyolite; sparse fine-grained phenocrysts of oligoclase, sanidine, quartz, and rare biotite are evenly distributed throughout the dome.
7. A large lens of crystalline felsite, approximately 60 m wide and 180 m long, is present at the northeast margin of the dome; numerous small contorted and fractured bands of this syneruptive "crystalline mush" extend into the main body of glass.
8. Flow-banding is dominantly defined by flattened microvesicles and locally by stringers of syneruptive felsite; flow-banding is generally steep, irregular and roughly defines a concentric pattern within the dome.
9. Density and microvesicularity are inversely proportional; over a 90 m vertical transect; density generally increases downward from about 1.8 gm/cc to about 2.2 gm/cc; small lenses of dense nonvesicular perlite locally occur near the center of the dome.
10. Some samples of dense microvesicular perlite from the core area contain rare microscopic nodules of obsidian, 0.1–0.2 mm in diameter.

A confident interpretation of the eruptive history for this high-silica rhyolite lava dome will require additional and deeper drilling to define more precisely its original geometry and the total distribution of perlite ore. Based on available data, we suggest the following tentative eruptive history.

Initial eruptions at about 7.85 Ma began with a "throat clearing" series of pyroclastic events including small volume ash-flow tuffs and ash falls. Shortly thereafter a highly viscous, slightly volatile enriched, high-silica magma rose slowly in the open conduit toward the surface. Chilling of the magma cap, at or near the vent walls (at elevated vapor pressure?), locally formed a granophyric crystallite mush, which became part of the initial surface extrusion. Finally a viscous, foamy, high-silica melt was then very slowly extruded through a confined(?) orifice to pile up as a small circular steep sided and flat-topped mass with a total volume of about 0.03 km<sup>3</sup> (Table 4). Termination of extrusion at this point allowed the relatively small mass to cool as a simple unit. The combination of cooling by gas expansion (vesiculation), cooling by gas escape (dehydration), extreme viscosity, and relatively large ratio of surface area to thermal mass, apparently allowed this small body to cool quickly enough that the commonly observed crystalline core did not form. Flow fractures, cooling cracks, microfractures, and flattened microvesicles formed a highly permeable body of obsidian, which was then readily altered by meteoric waters into a small, but unusually high-yield body of commercial perlite.

#### Grants perlite deposit

The Grants perlite deposit, mined by U.S. Gypsum, is located approximately 13 km northeast of the town of Grants in west central New Mexico. Our rudimentary knowledge of this perlite deposit is primarily from publications by Kerr and Wilcox (1963), Thaden et al., (1967, geologic map, 1:24,000), and Barker et al., (1989). The Grants perlite is a glassy phenocryst-poor high-silica rhyolite lava (Table 2) that initially yielded K—Ar ages on obsidian ranging from 2.7 to 3.8 Ma (Bassett et al., 1963). A more recent K—Ar age determination of 3.34 ± 0.16 Ma by Lipman and Mehnert (1980) is considered to be the most reliable determination available at present. This high-silica lava dome was one of the earliest eruptions of the Mount Taylor volcanic field (Crumpler, 1982). The dome was buried by ash, volcanoclastic sediments, and lava flows by about 2.5 Ma. Quaternary erosion has exhumed most of the original high-silica lava dome.

The Grants perlite deposit lies at the northeast end of an elliptical, flow-banded, mostly lithoidal (crystalline) rhyolite lava dome that is approximately 2.4 km long and 1.6 km wide. It rises 180–240 m above nearby exposures of Upper Cretaceous sandstones and shales, which appear to define the pre-eruption surface. Kerr and Wilcox (1963) indicate that the perlite deposit is separated from the main body of lithoidal rhyolite by an interval of rhyolitic tuffs. This overall geometry implies that the main body of lithoidal rhyolite represents a large composite lava dome (Fig. 4C) and that the perlite deposit is either a stubby subhorizontal lava flow or a steeply inclined flow at the outer margin of the composite dome. A determination of the cooling geometry of the Grants perlite deposit should aid greatly in the utilization of this resource.

The Grants composite dome has an estimated volume

of 0.25 km<sup>3</sup> and probably contained no more than about 5% accessible obsidian on its outer surface shortly after eruption. The lateral extent of commercial perlite at the Grants mine appears to be limited to the present quarry area. An unpublished company report (cited in Austin and Barker, 1995) of an unmined perlite thickness of 390 m (indicated by drilling) appears to be geologically unlikely.

#### Summary and conclusions

Perlite is an *altered* (weathered) rhyolitic glass that contains 2–5 wt.% water. Most of New Mexico's perlite production comes from the weathered, glassy, flat tops and steep toes of high-silica rhyolite (75.0–77.5 wt.% SiO<sub>2</sub>) lava flows at the No Agua Peaks eruptive center of late Tertiary age (3.91 ± 0.27 Ma). An early 270 m high lava dome, which piled up over the primary vent at west peak, is mostly crystalline rhyolite and yields little perlite. Extremely vesicular lobate lava flows, which "leaked" from under the west flank of the primary dome, are relatively thin (75 m) and perlite-rich flows with as much as 50% recoverable perlite. Relatively thick (120 m) late-phase lava flows, were then extruded from a radial dike on the northeast flank of the primary dome. The late-phase eastern flows apparently encircled remnants of an early tuff—breccia cone. At twice the volume of the western flows, the thicker eastern flows are almost equally productive because they contain as much as 20% recoverable perlite. Our revised eruptive history for the No Agua Peaks volcanic center is primarily based on the well-documented concept of compositionally zoned high-silica rhyolite magma chambers and published geochemical data from the No Agua lavas. Relatively rapid and uniform bulk hydration of the obsidian-capped No Agua flows was made possible by a high initial-fracture permeability and interconnected microvesicles.

The small high-silica rhyolite dome near Socorro is unusually productive because it lacks the crystalline core commonly found in larger high-silica lava flows. This late Tertiary (7.85 ± 0.04 Ma) microvesicular dome (>95% glass) is at least 90 m thick and approximately 840 m in diameter. It apparently welled up within a tuff cone on the floor of an early basin of the central Rio Grande rift; and it was completely buried by about 4 Ma. The dome was then uplifted and exhumed along a Quaternary fault zone, thus providing access to the now uniformly hydrated glassy *core* of the dome.

Another exhumed high-silica rhyolite lava dome near Grants, which consists of over 95% crystalline rhyolite, yields moderate amounts of perlite from the eastern toe of the dome. This 3.3 Ma composite dome, as much as 210 m high, was temporarily buried by ash and lava flows from the western flank of the Mount Taylor stratovolcano.

New Mexico supplies over 80% of domestic perlite from these three geologic deposits. Most of this production comes from the world-class deposit at No Agua Peaks, which sustains two large mining operations. Dicaparl produces perlite from a strip mine on top of the vesicular flows that define the west flank of the volcanic center. Harborlite mines the crest and outer toes of the higher flat-topped peaks (flow lobes) that define the eastern flank of the volcanic center. Dicaparl also mines the Socorro deposit, and U.S. Gypsum operates the mine at Grants.

### Acknowledgments

We especially thank Nelia Dunbar for constructive comments on an early version of this manuscript. While the conclusions are our own, her insights concerning the role of magmatic water in rhyolite eruptions have been most helpful in our interpretation of eruptive events at the No Agua volcano. Also, many thanks to Dicaperl personnel, D. A. Jenkins and T. L. Hall, who provided helpful drill hole data for the Socorro and No Agua deposits.

Technical assistance was provided by Lynne Hemenway, Rebecca Titus, Kathy Glesener, and Mickey Wooldridge. George Austin and Gretchen Hoffman reviewed the manuscript and provided helpful comments. All discussions of perlite build on the pioneering work of Irving Friedman and his associates Robert L. Smith and William Long; we appreciate their careful research, they deserve our applause.

### References

- Aldrich, M. J., Jr., and Laughlin, A. W., 1984, A model for the tectonic development of the southeastern Colorado Plateau boundary: *Journal of Geophysical Research*, v. 89, pp. 10,207-10,218.
- Atwater, T., 1970, Implications of plate tectonics for the Cenozoic tectonic evolution of western North America: *Geological Society of America Bulletin*, v. 81, pp. 3513-3536.
- Austin, G. S., and Barker, J. M., 1995, Production and marketing of perlite in the western United States; *in* Tabilio, M., and Dupras, D. L. (eds), *Proceedings of the 29th Forum on the Geology of Industrial Minerals: California Department of Conservation, Division of Mines and Geology, Special Publication 110*, pp. 39-68.
- Barker, J. M., McLemore, V. T., Wilson, M. L., and Austin, G. S., 1989, East Grants Ridge-A mineral potpourri: *New Mexico Geological Society, Guidebook 40*, pp. 325-329.
- Bassett, W. A., Kerr, P. F., Schaeffer, O. A., and Stoenner, R. W., 1963, Potassium-argon ages of volcanic rocks north of Grants; *in* Kelley, V. C., (compiler), *Geology and technology of the Grants uranium region: New Mexico Bureau of Mines and Mineral Resources, Memoir 15*, pp. 214-216.
- Bobrow, D. J., Kyle, P. R., and Osburn, G. R., 1983, Miocene rhyolitic volcanism in the Socorro area of New Mexico: *New Mexico Geological Society, Guidebook 34*, pp. 211-217.
- Bowen, N. L., 1928, *The evolution of the igneous rocks: Princeton University Press, Princeton, New Jersey*, 334 pp.
- Breese, R. O. Y., and Barker, J. M., 1994, Perlite; *in* Carr, D. D. (ed.), *Industrial minerals and rocks, 6th ed.: Society for Mining, Metallurgy, and Exploration, Littleton, Colorado*, pp. 735-749.
- Breese, R. O. Y., 1984, Rhyolite domes and flows at No Agua Peaks, New Mexico: *New Mexico Geological Society, Guidebook 35*, pp. 373-374.
- Breese, R. O. Y., and Piper, J. R., 1985, Occurrence and origin of perlite: *Society of Mining, Metallurgy, and Exploration, Littleton, Colorado, Preprint no. 85-359*, 12 pp.
- Carmichael, I. S. E., 1979, Glass and the glassy rocks; *in* Yoder, H. S., Jr.(ed.), *The evolution of the igneous rocks-50th anniversary perspectives: Princeton University Press, New Jersey*, pp. 233-244.
- Chamberlin, R. M., 1980, Cenozoic stratigraphy and structure of the Socorro peak volcanic center, central New Mexico: Unpublished PhD dissertation, Colorado School of Mines, 532 pp. [NM Bureau of Mines and Mineral Resources, Open-file Report 118].
- Chamberlin, R. M., 1981, Cenozoic stratigraphy and structure of the Socorro peak volcanic center, central New Mexico-A summary: *New Mexico Geology*, v. 3, pp. 22-24.
- Chamberlin, R. M., Barker, J. M., and Jenkins, D. A., 1994, Economic geology of perlite production in New Mexico: *Society for Mining, Metallurgy, and Exploration, Littleton, Colorado, Preprint no. 94-255*, 24 pp.
- Chapin, C. E., Chamberlin, R. M., Osburn, G. R., White, D. L., Sanford, A. R., 1978, Exploration framework of the Socorro geothermal area, New Mexico: *New Mexico Geological Society, Special Paper no. 7*, pp. 115-129.
- Christiansen, R. L., and Lipman, P. W., 1966, Emplacement and thermal history of a rhyolite flow near Fortymile Canyon, southern Nevada: *Geological Society of America Bulletin*, v. 77, pp. 671-684.
- Crumpler, L. S., 1982, Volcanism in the Mount Taylor region, New Mexico: *New Mexico Geological Society, Guidebook 33*, pp. 291-298.
- Davis, P. M., Slack, P., Dahlheim, H. A., Green, W. V., Meyer, R. P., Achauer, U., Glahn, A., and Granet, M., 1993, Teleseismic topography of continental rift zones; *in* Iyer, H. M., and Hirahara, K. (eds.), *Seismic Tomography: Theory and Practice: Blackwell, London*, pp. 265-298.
- Fink, J. H., and Manley, C. R., 1987, Origin of pumiceous and glassy textures in rhyolite flows and domes: *Geological Society of America, Special Paper 212*, pp. 77-88.
- Friedman, I., and Long, W., 1976, Hydration rate of obsidian: *Science*, v. 191, pp. 347-352.
- Friedman, I., and Smith, R. L., 1958, The deuterium content of water in some volcanic glasses: *Geochimica et Cosmochimica Acta*, v. 15, pp. 218-228.
- Friedman, I., and Trembour, F. W., 1978, Obsidian: The dating stone: *American Scientist*, v. 66, pp. 44-51.
- Friedman, I., Long, W., and Smith, R. L., 1963, Viscosity and water content of rhyolite glass: *Journal of Geophysical Research*, v. 68, pp. 6523-6535.
- Friedman, I., Smith, R. L., and Long, W. D., 1966, Hydration of natural glasses and formation of perlite: *Geological Society of America Bulletin*, v. 77, pp. 323-328.
- Green, J., and Short, N. M. (eds.), 1971, *Volcanic landforms and surface features: A photographic atlas and glossary: Springer-Verlag, New York*, 519 pp.
- Hildreth, W., 1981, Gradients in silicic magma chambers-Implications for lithospheric magmatism: *Journal of Geophysical Research*, v. 86, no. B11, pp. 10,153-10,192.
- Humphreys, E. D., and Dueker, K. G., 1994, Physical state of the western U.S. upper mantle: *Journal of Geophysical Research*, v. 99, no. B5, pp. 9635-9650.
- Kadey, F. L., Jr., 1983, Perlite; *in* Lefond, S. J. (ed), *Industrial Minerals and Rocks, 5th ed.: American Institute of Mining, Metallurgy, and Petroleum Engineers, Littleton, Colorado*, pp. 997-1015.
- Kerr, P. F., and Wilcox, T., 1963, Structure and volcanism, Grants Ridge area, New Mexico: *New Mexico Bureau of Mines and Mineral Resources, Memoir 15*, pp. 205-213.
- Lipman, P. W., and Mehnert, H. H., 1979, The Taos Plateau volcanic field, northern Rio Grande rift, New Mexico; *in* Riecker R. E. (ed.), *Rio Grande rift: Tectonics and magmatism: American Geophysical Union, Washington, D.C.*, pp. 289-311.
- Lipman, P. W., and Mehnert, H. H., 1980, Potassium-argon ages from the Mount Taylor volcanic field, New Mexico: *U.S. Geological Survey, Professional Paper 1124-B*, 8 pp.
- Loney, R. A., 1968, Flow structure and composition of the southern coulee, Mono Craters, California-A pumiceous rhyolite flow: *Geological Society of America, Memoir 116*, pp. 415-440.
- Mahood, G., and Hildreth, W., 1983, Large partition coefficients for trace elements in high-silica rhyolites: *Geochimica et Cosmochimica Acta*, v. 47, pp. 11-30.
- Manley, C. R., and Fink, J. H., 1987, Internal textures of rhyolite flows as revealed by research drilling: *Geology*, v. 15, pp. 549-552.
- Marshall, R. R., 1961, Devitrification of natural glass: *Geological Society of America Bulletin*, v. 72, pp. 1493-1520.
- Naert, K. A., 1974, *Geology, extrusion history, and analysis of perlites from No Agua, New Mexico: Unpublished PhD dissertation, Pennsylvania State University*, 223 pp.
- Naert, K. A., Wright, L. A., and Thornton, C. P., 1980, *Geology of the perlite deposits of the No Agua Peaks, Taos County, New Mexico: New Mexico Bureau of Mines and Mineral Resources, Open-file Report 162*, 88 pp.
- Ohle, E. L., and Bates, R. L., 1981, *Geology, geologists, and min-*

- eral exploration: Economic Geology, 75th Anniversary Volume, pp. 766-774.
- Smith, R. L., Bailey, R. A., and Ross, C. S., 1970, Geologic map of the Jemez Mountains: U.S. Geological Survey, Miscellaneous Investigations Map 1-571, scale 1:125,000.
- Spell, T. L., Kyle, P. R., Thirlwall, M. F., and Campbell, A. R., 1993, Isotopic and geochemical constraints on the origin and evolution of post-collapse rhyolites in the Valles caldera, New Mexico: *Journal of Geophysical Research*, v. 98, no. **B11**, pp. 19,723-19,739.
- Spence, W., and Gross, R. S., 1990, A topographic glimpse of the upper mantle source of magmas of the Jemez lineament, New Mexico: *Journal of Geophysical Research*, v. 95, pp. 10,829-10,850.
- Swanson, D. A., Dzurisin, D., Holcomb, R. T., Iwatsubo, E. Y., Chadwick, W. W., Jr., Casadevall, T. J., Ewert, J. W., and Heliker, C. C., 1987, Growth of the lava dome at Mount St. Helens, Washington (USA), 1981-1983: Geological Society of America, Special Paper 212, pp. 1-16.
- Taylor, H. P., 1968, The oxygen isotope geochemistry of igneous rocks: *Contributions to Mineralogy and Petrology*, v. 19, pp. 1-71.
- Thaden, R. E., Santos, E. S., and Raup, O. B., 1967, Geologic map of the Grants Quadrangle, Valencia County, New Mexico: U.S. Geological Survey, Map GQ-681, scale 1:24,000.
- Weber, R. H., 1963, Geologic features of the Socorro perlite deposit: New Mexico Geological Society, Guidebook 14, pp. 144-145.
- Weber, R. H., and Austin, G. S., 1982, Perlite in New Mexico; *in* Austin, G. S. (compiler), *Industrial rocks and minerals of the Southwest: New Mexico Bureau of Mines and Mineral Resources, Circular 182*, pp. 97-101.
- Westrich, H. R., Stockman, H. W., and Elchelberger, J. C., 1988, Degassing of rhyolitic magma during ascent and emplacement: *Journal of Geophysical Research*, v. 93, no. B6, pp. 6503-6511.
- Whitson, D., 1982, Geology of the No Agua Deposit at No Agua Peaks, New Mexico; *in* Austin, G. S. (compiler), *Industrial rocks and minerals of the Southwest: New Mexico Bureau of Mines and Mineral Resources, Circular 182*, pp. 89-95.
- Zielinski, R. A., Lipman, P. W., and Millard, H. T., Jr., 1977, Minor-element abundances in obsidian, perlite, and felsite of calc-alkalic rhyolites: *American Mineralogist*, v. 72, pp. 426-437.





# Natural clinker—The red dog of aggregates in the Southwest

Gretchen K. Hoffman

*New Mexico Bureau of Mines & Mineral Resources, New Mexico Tech, 801 Leroy Place, Socorro, New Mexico 87801-4796, USA*

**Abstract**—Clinker is generally a baked to fused to melted byproduct of the natural combustion of coal. Use of scoria, red dog, and baked shale to refer to the lithologies associated with natural coalburn are common, but these terms are confusing or poorly describe the material. The various lithologies and different degrees of melting associated with the coalburn make it difficult to use one term for the entire range of rock affected. Coal geologists refer to the baked rocks associated with naturally burned coal beds as clinker. Use of the term clinker in this paper refers to the result of natural coalburn not the byproducts of industrial or electrical operations.

Clinker is a result of coal combustion often attributed to human-produced fires such as prairie fires, or lightning strikes. However, spontaneous combustion may be a significant cause of coal burns that commonly occur in the subbituminous and lignite coal fields of the western United States. Because of their high moisture and oxygen content, low-rank coals have a greater tendency to self-heat. Many of these coals are aquifers and seasonal fluctuations in the water table can cause heat-of-wetting, an exothermic reaction. When the water level drops, the heat-of-wetting process increases oxidation and self-heating accelerates until smoldering or combustion occurs. Some investigators believe the presence of dispersed pyrite in the oxidizing coal significantly increases the potential for spontaneous combustion. Bituminous coals begin self-heating at 140°F but lignite and subbituminous coals can begin self-heating at 86°F. Clinker deposits are often found on the edges of drainage systems, where downcutting of streams exposes coal beds and fluctuations in the moisture enhance the possibility of heat-of-wetting leading to spontaneous combustion.

Investigations of clinker in Wyoming and North Dakota have looked at the origin of these deposits and their potential use as indicators of coal resources. The red, purple, or black colors caused by iron oxidizing during heating produce distinctive outcrops. Shale, mudstone, and siltstone closest to the burning coal are altered to a brick-like material and nearby sandstone is hardened by heat. These rocks often are more resistant to erosion than the unbaked sequences, resulting in prominent topographic features. The hardness of clinker is useful in some applications of industrial minerals.

Much of the San Juan Basin in northwest New Mexico has outcrops of soft shale, siltstone, coal, sandstone, and clinker. Common aggregates such as limestone, sand, and gravel are not readily available. Use of clinker as road base on some New Mexico county gravel roads is common where there is no other suitable material and clinker deposits are nearby. In New Mexico and Arizona a few coal mines use clinker on their mine roads, for reclamation purposes, and for stabilization. Peabody's Arizona Black Mesa mines have experimented with clinker as an aggregate for concrete, but it did not have the required strength for permanent structures.

The New Mexico State Highway Department has tested several clinker deposits in the San Juan Basin. The different rock types and the degree of heating result in variable quality. Los Angeles (LA) abrasion-test results range from 24.8 to 47.9% and the soundness test from 1.5 to 11.5%. These LA abrasion figures (percentage of weight loss during tumbling) are high, making most of the clinker deposits unacceptable for paved-road base, but the soundness values (how material withstands the freeze-thaw cycle) are within the acceptable range. Because of the variation in quality, the use of clinker is dependent on the availability and cost of other aggregates.

## Escoria natural de carbon—el *Perro Colorado* de agregados en el Suroeste

**Resumen**—Escoria (*clinker*), en general, es un producto secundario de la combustión de yacimientos de carbón. A las litologías asociadas se las designa comúnmente con términos tales como *escoria*, *perro colorado* (*red dog*), *esquisto cocido*. Estas designaciones son imprecisas. Por otro lado, un solo término no basta para describir toda la gama de litologías y diversos grados de fusión resultantes. Los geólogos del carbón llaman *clinker* a las rocas calcinadas asociadas con estratos de carbon quemados naturalmente. En este trabajo se designa como *clinker* el resultado de combustión natural o espontánea de estratos de carbón en contraposición con los productos secundarios de operaciones industriales o eléctricas.

La producción de *clinker* es el resultado de la combustión de carbon muchas veces atribuible a la acción humana, tales como incendios de campo, o a procesos naturales, por ejemplo relámpagos. Además de estos factores, una causa importante de incendios puede ser la combustión espontánea en yacimientos de carbón sub-bituminoso o de lignito en el oeste de los Estados Unidos. Debido a su alto contenido de humedad y oxígeno, carbons de bajo rango tienen mayor propensión a

## Introduction

Natural-clinker deposits are very common in the low-rank-coal regions of the western United States, particularly in Montana, North Dakota, and Wyoming. Over a thousand square miles of clinker have been mapped in the northern Powder River Basin of Montana alone (Heffern et al., 1993). The distinctive red to purple color of clinker deposits and their resistance to weathering yield unique outcrops. They are different from the normal dull gray, tan, and black of the coal-bearing sequences. These deposits have long been recognized as an indicator of coal and are useful exploration tools for the coal geologist in locating coal seams. Rarely is clinker considered a potential source of aggregate. However, a lack of good local aggregate has led many coal mines and county road departments in the western United States to use clinker as an economic alternative to long hauls from more traditional aggregate deposits.

## Terminology

In 1918, Rogers published a detailed study of clinker deposits in Montana, calling the material baked shale or slag. Blain's (1954) discussion of North Dakota occurrences noted that "scoria" referred to the entire baked-rock sequence and "clinker" was only used to refer to the fused slag-like masses within the baked deposits. Blain felt scoria was incorrectly used in referring to sedimentary rocks and thought the term clinker was more appropriate in discussing the heavy, black, vesicular, slag-like masses found within the section of baked rock. Coates (1980) defined clinker as the baked rocks associated with coal burning in place. Sarnecki (1991) de-

scribed clinker as "a rock sequence because the overburden from which it originates is a mix of different rock types, and heat from the burning coal creates several new rock types." To most coal geologists, and in this paper, clinker or clinker deposit refers to a rock sequence altered by an adjacent coal bed burning in place instead of the manufactured consequence of an industrial operation or electrical generation process.

## Formation of clinker

Clinker is the result of coal combustion caused by prairie or forest fires, lightning strikes, human-produced fires, and spontaneous combustion. Spontaneous combustion takes place most often in low-rank coals because of their high moisture, volatile matter, and oxygen content. Lignite and subbituminous coal beds in the western United States (Fig. 1) are commonly aquifers. Heat-of-wetting (Kuchta et al., 1980) can occur when water levels fluctuate in the coal aquifer because of seasonal changes, increasing oxidation and self-heating to a point of smoldering and combustion. The downcutting of streams through coal beds can also start the heat-of-wetting process; as a result, clinker deposits are common along drainage patterns. Downcutting may lower the water table, allowing methane and volatile matter to be desorbed, influencing the possibility of ignition (E. L. Heffern, Bureau of Land Management, pers. comm. 1995). The minimum self-heating temperature for bituminous coal is 140°F, but for lignite and subbituminous coal beds it is as low as 86°F (Kuchta et al., 1980). Higher-rank coals do not naturally combust unless mined or stored in stock piles. Factors influencing spontaneous combustion of

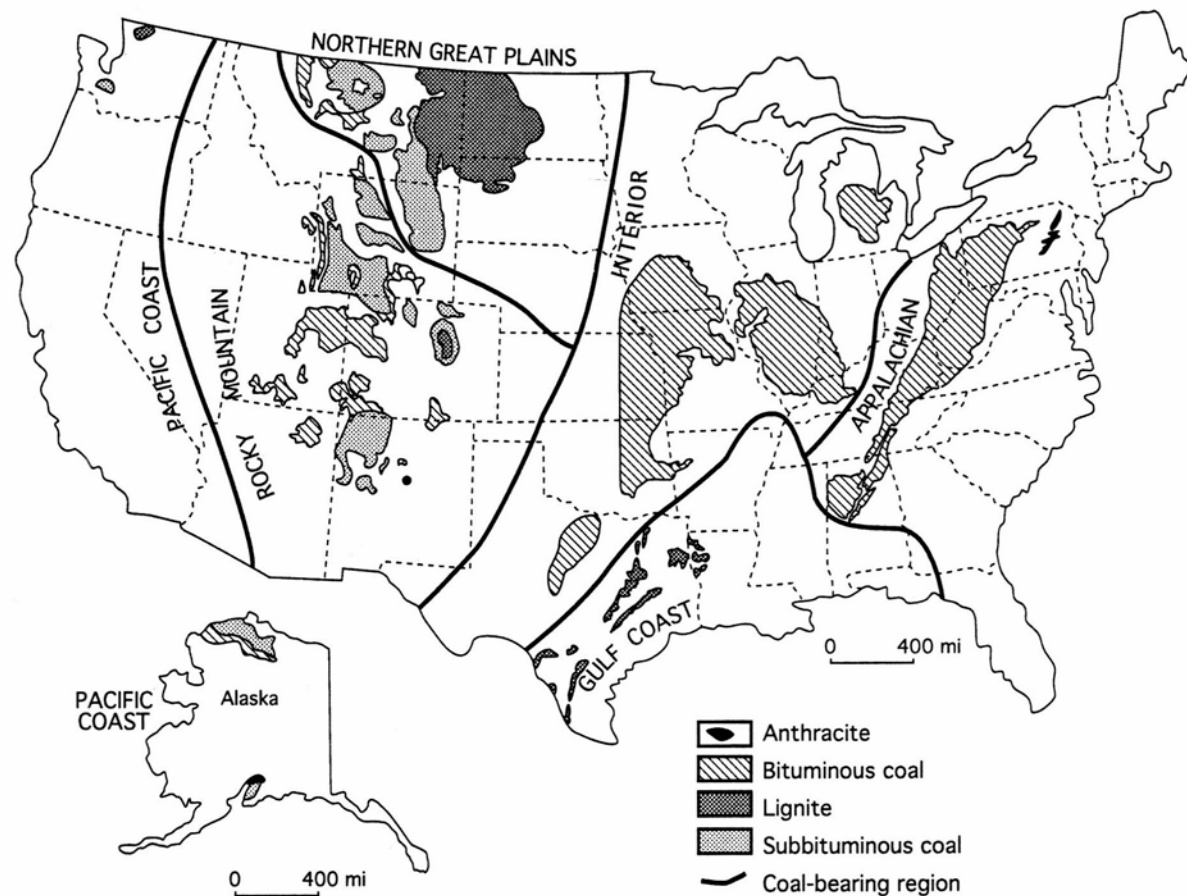

FIGURE 1—Coal-bearing areas of the United States. Major areas of clinker deposits are in the subbituminous and lignite coal fields of the Rocky Mountain and northern Great Plains areas. Modified from Energy Information Administration, December 1994.

stock piles are good air flow and increased surface area (Herring, 1980). Pyrite content is often mentioned as a possible factor in spontaneous combustion. Studies by Kim (1977) suggest that coal may be more susceptible to spontaneous heating if fine-grained pyrite is distributed throughout the coal. The pyrite concentration must exceed 2% before it is a significant factor in combustion. Most of the western coals are low in sulfur, less than 1%, therefore pyrite is not considered a significant factor in their combustion. Sarnecki (1991) reported coal beds thicker than 5 ft are more prone to spontaneous combustion. Some evidence exists that beds less than 3 ft thick have ignited during prairie fires (E. C. Murphy, North Dakota Geological Survey, pers. comm. 1994; and D. A. Coates, U.S. Geological Survey, pers. comm. 1995). Some investigators believe prairie and forest fires are probably the principal cause of coal-bed fires resulting in clinker (D. A. Coates and E. L. Heffern, pers. comm., 1995).

#### Lithology

Different rock types occur within a clinker deposit because of varying lithology overlying the coal and varying degrees of heat. The rocks under the burned coal show little or no evidence of heat alteration, suggesting that most of the heat is dissipated laterally or upward by advection (Cosca et al., 1989). Coal combustion leaves an ash that is only 5-10% of the original thickness of the coal bed, depending on ash content of the coal. Often the ash layer is not present because it easily erodes or dissolves. Fine-grained rocks immediately above the burn

ing coal bed or along the sides of chimneys may melt completely, forming highly vesicular, glass-like material that Cosca et al. (1989) called paralava. Above the paralava, the rocks are partially melted to a dense, brick-like rock called buchite or more appropriately porcellanite (Fig. 2; Sarnecki, 1991; D. A. Coates, pers. comm. 1995). Porcellanite is fused shale or clay that exhibits conchoidal fracture and ranges in color from gray to yellow-beige to deep red, depending on the iron geochemistry. Above the porcellanite, baked rocks display color changes depending on their iron geochemistry and thermal gradient, but retain more of their original textures and bedding (Fig. 3). Instead of being indurated, some claystones and shales are more friable than in their original state. Clark and Peacor (1992) found that low to moderate temperatures caused delamination in phyllosilicates due to dehydroxylation. This delamination results in very friable material. Sandstones in the sequence above the coalburn commonly become better indurated and can be of reddish color. As the coal burns back from the outcrop, a void is created, resulting in a rotational slumping of the overburden (Coates, 1988). A collapse can smother the fire, but often creates fractures allowing fresh air to reach the burning coal, rejuvenating the fire. Gases formed during the burning of coal escape upward through these vents and combust when they interact with fresh air (Fig. 2). The heat generated by the burning gases is sufficient to melt the adjacent rock. Some melted overburden collapses, breaks, and falls into the vents. The molten rock (paralava) cements the collapsed material into a welded breccia (Fig.

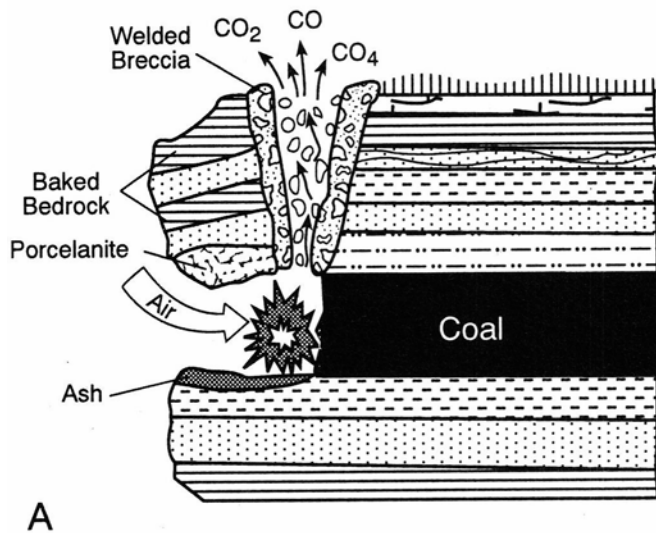

A

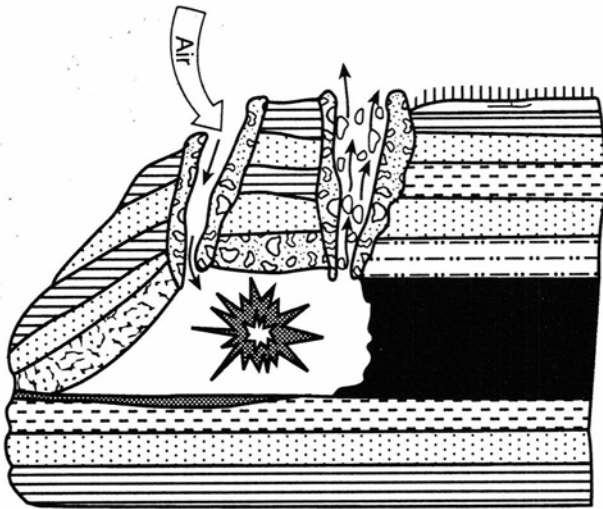

B

FIGURE 2—Clinker formation sequence: A, Initial clinker formation due to natural combustion at the coal outcrop showing resultant rock types. B, Post-collapse burn continuation set up by circulation of air to fire chamber through vents. Fresh-air flow is shown by white arrows, exhaust-gas flow is shown by black arrows in exhaust vents. Zone of alteration occurs to the left of, and includes, the exhaust vent. From Sarnecki (1991) reproduced with permission of Techbooks.

4). This forms highly resistant chimney-like structures within the laterally more extensive clinker (Figs. 2 and 5).

#### Previous work

Lewis and Clark (1814) recognized clinker on their expedition into the western territories. Rogers (1918) discussed the formation of clinker and looked at the petrology of the different rocks formed from coal burning in place. Two descriptive studies on clinker in North Dakota are by May (1954) and Blain (1954). Several studies by Coates (1980, 1984, 1988) examined clinker in the Powder River Basin, Wyoming. These studies dealt with clinker formation and its effect on the landscape, and age-dating of detrital zircons in the clinker along headlands to document the development of headlands. Coates (1984) also discussed the use of magnetite-rich spinel in clinker for paleomagnetic studies. Heffern et al. (1993)



FIGURE 3—Outcrop of clinker in upper Menefee Formation, southeast San Juan Basin. Original bedding apparent, although most of the sequence has been baked by the underlying coal. Dark layer consists of iron concretions.



FIGURE 4—Closeup of welded breccia at the Peabody mine aggregate pit. Large pieces of baked shale and siltstone are welded together by glass-like material.



FIGURE 5—Large chimney structure at Peabody mine aggregate pit. The chimney walls consist of welded breccia formed during the venting of combustible gases. All the other material around this structure has been mined out, but this material is firmly in place and cannot be moved.

mapped extensive clinker deposits in the northern Powder River Basin in Montana.

Recognition of the role of clinker in finding coal resources and in mine design are parts of the recent studies by Budai and Cummings (1984) and Sarnecki (1991). Using clinker to map coal occurrences has long been a

tool of the coal geologist because of their (1) distinctive color and (2) relative topographic prominence owing to greater resistance to weathering. These rocks have increased magnetism from being baked in reducing conditions (Coates, 1984), and Sarnecki (1991) suggests that aerial or surface magnetic surveys could help to delineate the extent of the burn back from the outcrop and the location of unburned coal. Once the boundary between coalburn and remaining coal is detected, core drilling is necessary to determine the quality of the in-place coal. In practice, mines usually depend on drilling to delineate the boundary between burn and economic coal.

Few investigators discuss in print the use of clinker as an industrial mineral. Sarnecki (1991) recognized the variable strength of clinker and its potential to be an aquifer because of its highly fractured nature. He suggested that mine engineers need to be aware of the variable strength and fractured nature of clinker before locating structures at the mine, and stressed the need for strength tests to determine if this material is suitable as road-base material for haul roads. For reclamation purposes, he felt porous clinker could be used in alluvial runs and main recharge zones of reconstructed spoil aquifers to return to steady-state conditions and possibly reduce total dissolved solids. Clinker's resistance to weathering may cause it to deteriorate slower than other spoil.

**Occurrences in New Mexico and Arizona**

The San Juan Basin (SJB) covers an area of about 26,000 mil in northwestern New Mexico and southwestern Colorado. This basin extends into eastern Arizona along its southwestern margin. The Cretaceous portion of the basin has a north-south dimension of about 180 mi and is about 150 mi wide (Fig. 6). Structural components of the SJB have been present to some extent as

early as in mid-Paleozoic time, but the basin's present form is largely a Laramide phenomenon (Beaumont, 1993). The structural axis of the basin has a northerly and westerly arcuate trend that is nearer the eastern and northern margins.

All three major Upper Cretaceous coal-bearing sequences in the SJB, northwest New Mexico, have clinker deposits (Fig. 6). The Fruitland and Menefee Formations have more clinker than the older Crevasse Canyon Formation. Clinker has been mapped by several investigators and its outcrops are easy to recognize on color aerial or color infrared photographs. These deposits often occur along the major drainage systems in the area where streams have cut down through the coal. Most of the clinker is along the Chaco River, a major drainage area on the west side of the basin that continues along a south-east trend. This trend parallels the Chaco slope where the Upper Cretaceous rocks dip gently to the northeast (Fig. 6). On the edge of the basin, many Menefee and Crevasse Canyon coal outcrops in the Gallup area have burned, creating clinker.

Although numerous outcrops occur within the basin, very few are mined for aggregate, in part because better material is available. The only commercial pits are in the Gallup area. One sells clinker to the public, and the other operation is almost totally dedicated to mining clinker for use at the McKinley coal mine northwest of Gallup (Fig. 6, sample location G).

Black Mesa in northeast Arizona is an erosional remnant of Upper Cretaceous rock surrounded by older Mesozoic sedimentary rocks (Fig. 7). The Cretaceous rocks are folded into long, broad synclines and anticlines. Wepo Formation coal reserves in the northern part of Black Mesa are preserved within the Maloney and Black Mesa synclines trending north-south and

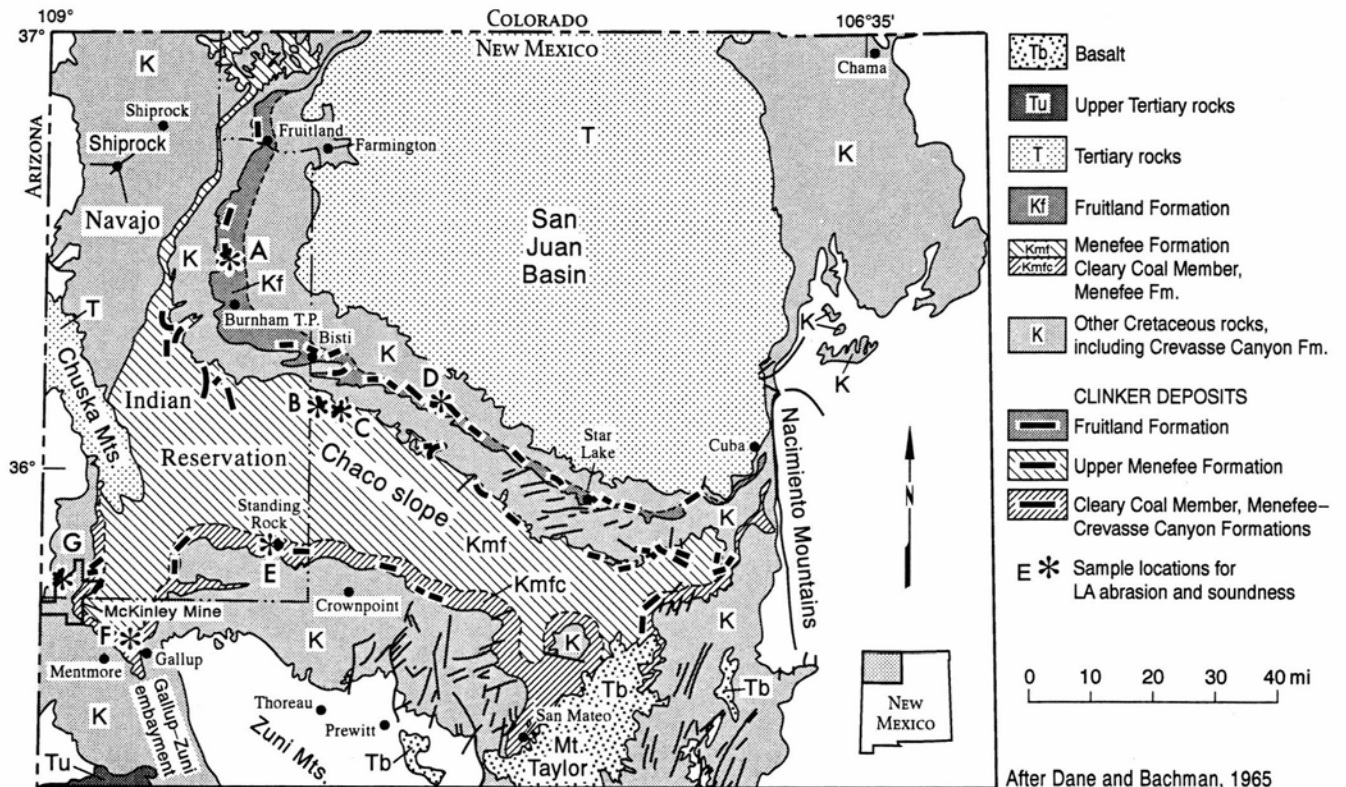

FIGURE 6—Index map of coal-bearing sequences in the San Juan Basin with locations of clinker outcrops and sample locations for Table 1.



northwest—southeast, respectively (Fig. 7). The Maloney syncline cuts across the Peabody coal lease (Black Mesa and Kayenta mines) and the coal-bearing formation thins to the northeast, away from the syncline. Wepo coal outcrops in the northern part of the mesa and coalburn areas are specifically mentioned by Peirce et al. (1970) and Reppenning and Page (1956).

#### Uses

Road base is the primary use of clinker material in New Mexico and Arizona in areas where aggregates such as limestone and sand and gravel are not available. The Sandoval County Road Department uses this material on unpaved roads in the southeast SJB. All of Sandoval County's clinker pits are on private land and the county pays the landowners \$3-7/yd<sup>3</sup> of rock. Crushing equipment is not available, so when mining with a front-end loader at the outcrop the preferred material is the baked shale or porcellanite that breaks into smaller pieces rather than the baked sandstone or welded breccia.

A private contractor (Jim Stephens) holds a Bureau of Land Management lease on a clinker deposit adjacent to the Pittsburg and Midway's McKinley coal mine. Most of the material from this pit is used at the McKinley mine. The entire rock sequence of the clinker deposit is crushed and sieved to minus 2 1/2 inch aggregate for use as road base on the haul roads. Approximately 30,000 yd<sup>3</sup> per year are produced from this pit.

Many clinker outcrops are within the Peabody coal lease; some are used for aggregate and other deposits

become part of the spoil during the mining sequence. Peabody has two main pits for mining and crushing clinker to use as road-base material. For each of the five active coal pits on the two mines within the Peabody lease, borrow pits supply clinker aggregate for nearby drainage and spillways. Peabody contracts to an outside company for mining, crushing, and screening of 200,000 yd<sup>3</sup> of material every other year for road base and backfill from two pits within their lease property. Clinker is sized at minus 3 inch for haul roads and minus 1 1/2 inch aggregate for backfill. The cost for the clinker after crushing and screening is \$4-5 yd<sup>3</sup> (R. Lehn, Peabody Western, pers. comm. 1995). Both coal-mine properties and Sandoval County use a thick layer (10-16 inches) of clinker on their roads because the material breaks down quickly. Resurfacing is done every 3-5 years on the Sandoval County roads using only baked shale. The mines resurface every 5-6 years, suggesting that either the combination of baked shale, sandstone, and paralava is more resistant or crushing to uniform size is beneficial. Clinker also breaks into angular fragments, particularly the porcellanite, which is very abrasive to tires when a new layer is applied to the road. The clinker exhibits excellent drainage properties that help to keep the haul roads from getting water-soaked.

Both the McKinley and Peabody coal mines use clinker directly from the pit to control water erosion in drainage areas, spillways, and ditches. The porcellanite is less dense and breaks down, making it marginal as rip-rap material, but when mixed with the baked sandstone, paralava, and welded breccia, it appears adequate in controlling erosion. At the Peabody property, a mixture of large- and small-size clinker along dam facings and spillways has been used with success (Figs. 8, 9). Engineers at this property also have used clinker as a "rock mulch" to stabilize a slope along a temporary road (Fig. 10). Applying six inches of rock mulch to the slope as a stabilizer has kept erosion to a minimum for two years (R. Lehn, pers. comm. 1995). This area will go through the regular reclamation process once mining is complete.

The fine-sized clinker, remaining after crushing and sieving, serves as traction on icy paved roads within the mines. At the McKinley mine, fine-sized clinker is used as a base material under concrete slabs to promote drainage. Both mines are using boulder-size clinker material for constructing "animal habitats" in their reclaimed areas.

Peabody mine engineers have tried using clinker as an aggregate in mixing concrete and asphalt. The mate-

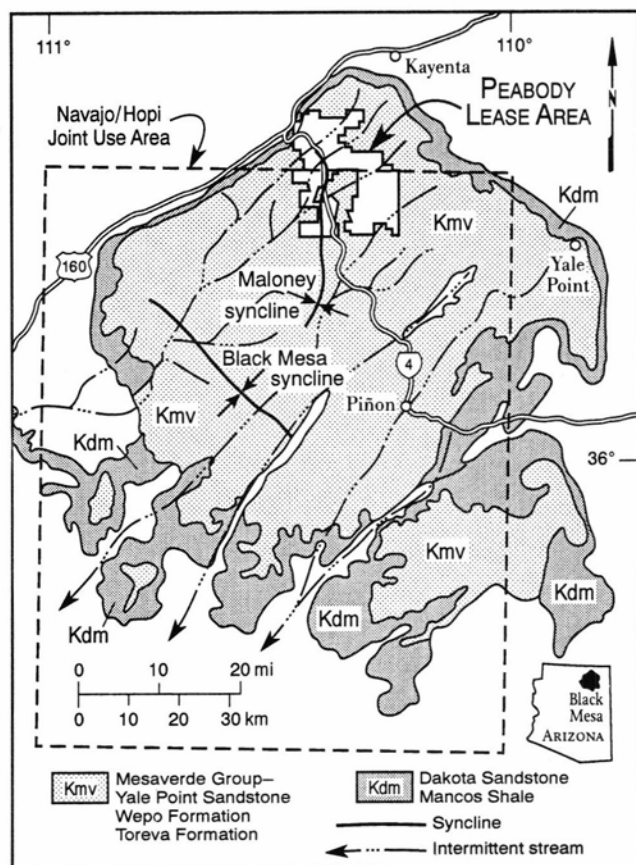

FIGURE 7—Cretaceous outcrops and synclinal features on Black Mesa, northeast Arizona. Location of Peabody Coal Company lease shown. Modified from Monore (1977) and Reynolds (1988).



FIGURE 8—Dam-facing made of large clinker material at Peabody Black Mesa mines, northeast Arizona.





FIGURE 9—Spillway lined with clinker at Peabody Black Mesa mine. Material is taken directly from a borrow pit nearby; the size of the aggregate is variable.



FIGURE 10—Rock “mulch” used to stabilize slope along temporary road. Road also has base of clinker.

rial is unsuitable for concrete because it takes too much water and detracts from the strength properties of the concrete. Both D. A. Coates and E. L. Heffern (pers. comm. 1995) mentioned seeing concrete made with clinker in the Powder River Basin. In some cases the clinker material had weathered out, leaving holes in the concrete. The asphalt application at the Black Mesa mines also had its drawbacks because the clinker absorbed too much of the oil.

Near the San Juan mine northwest of Farmington, New Mexico (Fig. 6), a small clinker deposit has been mined in the past for landscaping material. Clinker is used for landscaping in the Powder River Basin and surrounding areas (E. L. Heffern, pers. comm. 1995).

### Quality and testing

Use of clinker material is dependent on its availability near the location where it is to be applied. If a better source of aggregate requires transportation, creating an additional expense for the mines or county road departments, clinker is used. Two other counties, San Juan and McKinley, contain clinker deposits, but their road departments do not use them because they have access to better material. The New Mexico State Highway Department (NMSHD) has tested clinker for soundness (percent lost during simulated freeze—thaw situation) and LA abrasion (percent lost during tumbling). Results of these tests are in Table 1. The state of New Mexico

does not use clinker as a road base for paved roads, although it is used in Wyoming (E. L. Heffern, pers. comm. 1995) perhaps because of availability. Clinker deposits are not large enough to meet the highway-department needs and the LA abrasion tests show the material to be variable and of marginal quality, ranging from 24.8 to 47.9% loss by weight. Abrasion loss should be less than 30% (Goldman, 1994), although the NMSHD set its abrasion limit at 38% loss. From the available tests, a sandstone sample had the worst abrasion loss (98.5%). This sandstone was probably friable and not baked significantly by the coalburn. Soundness results are better, ranging from 1.8 to 11.5% loss by weight. All but one sample was within the minimum standard of less than 10% loss (Goldman, 1994).

For this study four samples were taken from the Peabody Black Mesa property and the clinker pit adjacent to the Pittsburg and Midway's McKinley mine and analyzed at the NMSHD testing laboratories (Table 1). Crushed clinker from stockpiles at each property (Samples G<sub>1</sub> and H<sub>1</sub>) were collected for analyses. A borrow-pit sample on the Peabody lease (H<sub>2</sub>) and a porcellanite sample from the McKinley mine (G<sub>2</sub>) were tested as a comparison to the mixed material crushed at each mine. The crushed material which both coal mines use on their haul roads is of good to fair quality with abrasion exceeding 30% and soundness of below 10% (Table 1). The porcellanite sample from the McKinley

TABLE 1—Analyses of clinker deposits by the New Mexico State Highway Department Materials and Testing Laboratories. All information is from NMSHD except for sample G and H location, formation, quality, estimated quantity, material, and area sampled. \*Failed soundness test—no data available; †New Mexico State Highway Department, ca 1975; ‡New Mexico State Highway Department, 1968.

Sample letter	Location	Formation	LA Abrasion (% loss)	Soundness (% loss)	Quality	Estimated quantity (yd <sup>3</sup> )	Material	Area sampled
†A	T26N R16W	Fruitland	24.8	1.8	Good	150,000	baked shale	prospect pit
†B <sub>1</sub>	T22N R12W sec. 31	Menefee	28.7	11.5	Good	25,000+	baked shale	prospect pit
†B <sub>2</sub>	T22N R12W sec. 31	Menefee	98.5	—	—	—	sandstone	prospect pit
†C	T22N R13W sec. 31	Menefee	40.0	6.0	Fair	150,000	baked sh & ss	developed pit
†D	T22N R10W sec. 20	Fruitland	47.9	9.2	Good	100,000	baked shale	exploration site
†E	T18N R15W	Menefee	44.4	9.5	Fair	30,000	baked shale	established pit
†F	T16N R18W sec. 32	Menefee	35.6	—	Poor	10,000	baked shale	established pit
G <sub>1</sub>	T16N R20W sec. 6	Menefee	46.0	7.6	Fair	25,000 /year	mixed clinker	main pit, crushed
G <sub>2</sub>	T16N R20W sec. 6	Menefee	30.0	1.1	Good	—	porcellanite	main pit
H <sub>1</sub>	Peabody lease, AZ	Wepo	43.0	5.0	Fair	150,000 /year	mixed clinker	main pit, crushed
H <sub>2</sub>	Peabody lease, AZ	Wepo	33.0	20.4*	Poor	—	baked shale	borrow pit

mine aggregate pit had the best characteristics of the four samples. The borrow-pit sample from the Peabody mines did very poorly on the soundness test. The result of these four samples and the samples from NMSHD pits illustrate the variability of clinker and the need to test the material before use.

### Conclusions

Clinker deposits are common in low-rank coal areas of the western United States because of the high moisture, volatile matter, and oxygen content in the coal. The moisture in the coal increases the internal temperature through heat-of-wetting. Fluctuations in the water table can lead to heat-of-wetting and release of methane. Drops in moisture increase oxidation leading to smoldering and spontaneous combustion. Prairie and forest fires and lightning strikes can also cause coal outcrops to ignite. Once a coal bed ignites, the overlying rocks are baked differentially, depending on the distance from the coal and whether vents form near the fire front as the overlying rock collapses. The rocks nearest to the coal and next to vents melt and become glassy, forming paralava or a welded breccia. Other rock, particularly shale or mudstone, almost reach melting temperature and become brick-like rock called porcellanite. Much of the sandstone associated with coalburn is baked and hardened. This rock sequence makes up a clinker deposit which is distinctive because of its red to purple coloration and resistance to weathering.

Clinker is a tool for coal exploration and is useful as an aggregate in areas that are deficient in limestones or other suitable material. Although the LA abrasion characteristics of this material are variable, it is resistant to weathering during the freeze-thaw cycle. Applications of clinker are limited to road base, erosion control, and dam facings. Large-size clinker material is effective as animal-habitat shelters in reclaimed mine areas; it is used for landscaping in the Powder River Basin and surrounding areas. The fine-size material left after crushing and sieving works well for traction on icy roads. Clinker is rarely used when better-quality material is readily available, but when the cost of transportation becomes a factor in obtaining aggregate, clinker is an adequate substitute in many aggregate applications.

### Acknowledgments

The author wishes to thank Jim Stephens (Jim Stephens Inc.), Randy Lehn (Peabody Western), Buck Woodward (Peabody Western), and George Greigo (Sandoval County) for access to pits and mines and sharing their knowledge on use of clinker as an industrial mineral. Thanks to Jim Stokes of the New Mexico Highway Department testing laboratory for analysis of the clinker samples collected for this study. Discussions with Donald A. Coates (U.S. Geological Survey), Ed Heffern (Bureau of Land Management, Cheyenne, Wyoming), Ed Murphy (North Dakota Geological Survey), and Robert Russell (New Mexico Energy, Minerals, and Natural Resources Department) helped to provide valuable details about the development of clinker and its usage in the Southwest. Thanks to Ed Heffern and Donald A. Coates for reviewing this article and improving its content. Illustrations were done by Kathy Glesener and Rebecca Titus of the New Mexico Bureau of Mines and Resources drafting section.

### References

- Beaumont, E. C., 1993, Geologic setting; *in* Hoffman, G. K., Campbell, F. W., and Beaumont, E. C., Quality assessment of strippable coals in northwestern New Mexico: Fruitland, Menefee, and Crevasse Canyon Formation coals in San Juan Basin, and Moreno Hill Formation coals in Salt Lake field: New Mexico Bureau of Mines and Mineral Resources, Bulletin 141, pp. 7-9.
- Blain, W. S., 1955, "Scoria" of North Dakota; *in* Contributions to the geology of North Dakota: North Dakota Geological Survey, Bulletin 28, pp. 138-143.
- Budai, C. M., and Cummings, M. L., 1984, Geologic controls of coal burns and oxidized zones in the Antelope coal field, Converse County, Wyoming; *in* Proceedings of the 1984 symposium on the geology of Rocky Mountain coal, Bismarck, North Dakota, October 2-4, 1984: North Dakota Geological Society, Publication 84-1, pp. 168-183.
- Clark, B. H., and Peacor, D. R., 1992, Pyrometamorphism and partial melting of shales during combustion metamorphism: Mineralogical, textural, and chemical effects: Contributions to Mineralogy and Petrology, v. 112, no. 4, pp. 558-568.
- Cosca, M. A., Essen, J. W., Geissman, J. W., Simmons, W. B., and Coates, D. A., 1989, Pyrometamorphic rocks associated with naturally burned coal beds, Powder River Basin, Wyoming; *American Mineralogist*, v. 74, pp. 85-100.
- Coates, D. A., 1980, Formation of clinker by natural burning of coal beds in the Powder River Basin, Wyoming; *in* Carter, L. M. (ed.), Proceedings of the fourth symposium on the geology of Rocky Mountain coal, Golden, Colorado, April 28-29, 1980: Colorado Geological Survey, Resource Series 10, pp. 37-40.
- Coates, D. A., 1984, Progress of studies of clinker in western coal basins; *in* Proceedings of the 1984 symposium on the geology of Rocky Mountain coal, Bismarck, North Dakota, October 2-4, 1984: North Dakota Geological Society, Publication 84-1, pp. 200-201.
- Coates, D. A., 1988, Clinker produced by natural burning of Tertiary coal beds in the Powder River Basin and its effect on landscape; *in* Geological Society of America field trip guidebook, Centennial meeting, Denver, Colorado: Professional Contributions of the Colorado School of Mines, no. 12, pp. 220-221.
- Dane, C. H., and Bachman, G. O., 1965, Geologic map of New Mexico: U.S. Geological Survey, scale 1:500,000, 2 sheets.
- Energy and Information Administration, December 1994, Core Industrial Annual 1993: DOE/EIA-0804(93), p. 235.
- Goldman, H. B., 1994, Sand and gravel; *in* Carr, D. D., (ed.), Industrial minerals and rocks, 6th ed.: Society for Mining, Metallurgy, and Exploration, Littleton Colorado, pp. 873-875.
- Heffern, E. L., Coates, D. A., Whiteman, J., and Ellis, M. S., 1993, Geologic map showing distribution of clinker in the Tertiary Fort Union and Wasatch Formations, Northern Powder River Basin, Montana: U.S. Geological Survey, Coal Investigations Map C-142, scale 1:175,000.
- Herring, J. R., 1980, Geochemistry of clinker, naturally burning coal, and mine fires; *in* Carter, L. M. (ed.), Proceedings of the fourth symposium on the geology of Rocky Mountain coal, Golden, Colorado, April 28-29, 1980: Colorado Geological Survey, Resource Series 10, pp. 41-44.
- Lewis, M., and Clark, W., 1814, History of the expedition under the command of Lewis and Clark, Allen, P. (ed.): Bradford and Inskeep, Philadelphia, v. 1, pp. 180, 189.
- Kim, A. G., 1977, Laboratory studies on spontaneous heating of coal: U.S. Bureau of Mines, Information Circular 8756, 13 pp.
- Kuchta, J. M., Rowe, V. R., and Burgess, D. S., 1980, Spontaneous combustion susceptibility of U.S. coals: U.S. Bureau of Mines, Report of Investigations RI-8474, 37 pp.
- May, P. R., 1954, Clinker: North Dakota Geological Society Guidebook, southwestern North Dakota Field Conference, pp. 18-19.
- Moore, R. T., 1977, Chemical analyses of coal samples from the Black Mesa field, Arizona: Arizona Bureau of Mines, Circular 18, pp. 1-3.
- New Mexico State Highway Department, 1968, Geology and aggregate resources, Geology Section, District 3: New Mexico State Highway Department, Santa Fe, New Mexico.

- New Mexico State Highway Department, ca 1975, Geology and aggregate resources, Geology Section, District 3: New Mexico State Highway Department, Santa Fe, New Mexico.
- Peirce, H. W., Keith, S. B., and Wilt, J. C., 1970, Coal, oil, natural gas, helium, and uranium in Arizona: Arizona Bureau of Mines, Bulletin 182, pp. 11-41.
- Repenning, C. A., and Page, H. G., 1956, Late Cretaceous stratigraphy of Black Mesa, Navajo and Hopi Indian Reservations, Arizona: American Association of Petroleum Geologists Bulletin, v. 40, pp. 255-294.
- Reynolds, S. J., 1988, Geologic Map of Arizona: Arizona Geological Survey, Map 26, scale 1:1,000,000.
- Rogers, G. S., 1918, Baked shale and slag formed by the burning of coal beds: U.S. Geological Survey, Professional Paper 108A, pp. 1-10.
- Sarnecki, J. C., 1991, Formation of clinker and its effects on locating and limiting coal resources; *in* Peters, D. C. (ed.), Geology in resource utilization: TechBooks, Fairfax, Virginia, pp. 29-35.



# Advances in the understanding of the industrial mineral resources of the state of Georgia

Mark D. Cocker and Bruce J. O'Connor

*Georgia Geologic Survey, 19 Martin Luther King, Jr., Dr., S.W., Atlanta, Georgia 30334, LISA*

**Abstract**—An accelerated program of studies to improve the base of geological information on Georgia's mineral resources has recently been concluded. The projects range from detailed evaluations of individual mineral deposits to broad, regional investigations. Studied were heavy minerals, construction sand and gravel, offshore phosphates, as well as stratigraphy and geology of the kaolin belt in the Coastal Plain province; pegmatites, talc deposits, granite and granitic gneiss, and mafic and ultramafic rocks in the Piedmont and Blue Ridge provinces; and high-magnesium carbonate rocks (dolostones), ceramic clays and shales, manganese deposits, and coal in the Valley and Ridge province. Approximately 40 Georgia Geologic Survey publications, several open-file reports, and numerous non-Survey publications document the results of these projects. Data obtained during these studies should be helpful in defining feasibility of and guidelines for offshore mining, guidelines for protection of aquifers, construction material for continued growth of population centers in Georgia, and potential health hazards to drinking-water resources.

## Avances en el conocimiento de minerales industriales en el estado de Georgia

**Resumen**—Recientemente se completó un programa acelerado para mejorar la base de información geológica relacionada con recursos minerales del estado. Los proyectos varían desde la evaluación detallada de yacimientos individuales hasta amplias investigaciones regionales. En la Provincia de la Llanura Costanera esos estudios abarcaron minerales pesados, arena y pedregullo de construcción, fosfatos en la zona marina costanera (*offshore*), así como la estratigrafía y geología de la zona de ocurrencia de caolín. En la Provincia del Pie de Monte y de la Loma Azul (*Blue Ridge*) se examinaron las pegmatitas, depósitos de talco, granito, gneiss granítico y rocas máficas y ultramáficas. En la Provincia de Valles y Lomas (*Valley and Ridge*) se estudiaron carbonatos de alto contenido de magnesio (*dolostones*), arcillas y esquistos arcillosos cerámicos, depósitos de manganeso y de carbón. Unas 40 publicaciones del Servicio Geológico de Georgia, varios informes en archivo abierto al público y numerosas publicaciones hechas por profesionales no vinculados al Servicio Geológico documentan los resultados. La información ganada con estos estudios será útil para definir la practicidad de explotación minera en el mar costanero, para la reglamentación de estas actividades mineras, para reglamentar la protección de acuíferos, para guiar la producción de materiales de construcción en la expansión continuada de centros de población y para identificar riesgos a la salubridad de aguas potables.

### Introduction

Georgia is consistently among the top states in industrial mineral production. It ranked third in 1992. The value of non-fuel minerals produced in Georgia increased to \$1.35 billion in 1992, marking the 11th increase in 12 years (Sikich and O'Connor, 1994). In 1992 Georgia led the United States in the quantity and value of kaolin and total clays, quantity of granite, and the value of barite mined. Georgia also was second in the production of natural iron-oxide pigments (Sikich and O'Connor, 1994). However, until recently little modern information has been published concerning the geology of these mineral resources. Such information is critical for the economy of the state, protection of the state's environment, and regional planning for growth.

In 1982 the Georgia Geologic Survey Branch of the Environmental Protection Division initiated an Accelerated Economic Minerals Program (AEMP) to improve the geologic data base for selected mineral commodities in Georgia so that mining companies might initiate mineral exploration. The selection of specific mineral com-

modities was based on three criteria: (1) the commodity is currently not being mined or investigated, (2) the potential exists for the occurrence of the commodity in commercial quantities, and (3) the development of the commodity would have a significant impact on the economy of Georgia. These projects ranged from detailed evaluations of individual mineral deposits to broad, regional investigations (Shapiro, 1986, 1987, 1988, 1990). The program was terminated due to funding cutbacks in 1992, and not all projects were completed.

The purpose of this paper is to provide a summary of these recent studies conducted or sponsored by the Georgia Geologic Survey. The focus is on those studies that relate to the economic and environmental geology of Georgia. This paper includes nearly 100 references that resulted from the AEMP. O'Connor (1990) summarized historical development, information, and background references on Georgia's industrial minerals.

The AEMP included ten core and seven correlative projects (Tables 1 and 2). Eight of the ten core projects are commodity-oriented investigations, and two are re-

TABLE 1—Core projects.

1.	Geologic/mineral atlas of Georgia
2.	Compilation of mineral testing and consulting services
3.	Construction materials of the coastal plain
4.	Manganese and associated metals
5.	Heavy mineral sands
6.	Sulfides
7.	High-silica sands
8.	Magnesium
9.	Pegmatites
10.	Platinum

TABLE 2—Correlative projects.

1.	Gold
2.	Granite and granite gneisses
3.	Ceramic clays and shales
4.	Mafic and ultramafic rocks
5.	Coal
6.	Oil and gas
7.	Offshore phosphates

gional compilations. The seven correlative projects were already underway or scheduled for start-up at the time that the AEMP was legislatively funded in 1985.

### Geologic framework

Georgia is divided into six major physiographic provinces (Fig. 1), from north to south: the Appalachian Plateau, the Ridge and Valley, the Blue Ridge, the Piedmont, the Coastal Plain, and the Continental Shelf. The Ridge and Valley and Appalachian Plateau provinces in northwest Georgia are composed of folded and faulted Paleo

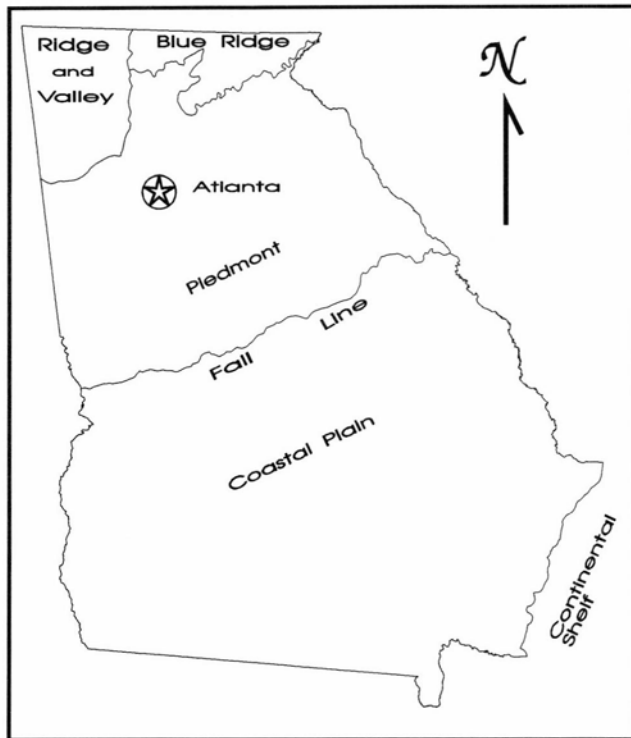

FIGURE 1—Physiographic provinces of Georgia with Atlanta and the Fall Line. The area shown as Ridge and Valley also includes the Appalachian Plateau province. General studies that include large portions of Georgia are: Koch, 1988; Koch and Koch, 1987, 1989; Koch et al., 1984; O'Connor, 1990; Steele, 1986; and Vincent, 1983.

zoic sedimentary rocks; the Blue Ridge and Piedmont Provinces in central Georgia are composed of Precambrian to Paleozoic igneous and metamorphic rocks; and the Coastal Plain and Continental Shelf provinces in south Georgia are made up of Cretaceous to Holocene sediments.

### Statewide mineral-resource information

Although information on previous mining activity and exploration is important for future mineral-exploration programs, regional planning, and environmental investigations, that information is scattered throughout voluminous literature and is not readily available to the mining industry, public, or government. Barrett (1983), Kellam (1986), Koch et al. (1984), Koch and Koch (1987, 1989), and McConnell and Abrams (1984) located known mines and prospects in Georgia from published and unpublished sources on topographic maps. These maps are on file at the Georgia Geologic Survey. Koch (1988) plotted regional stream-sediment geochemical data from the U.S. Department of Energy's National Uranium Resource Evaluation (NUKE) program as point maps for the northern two-thirds of Georgia. Vincent (1983) compiled a list of geoscience testing facilities in Georgia that were available in 1982. Steele (1986) summarized descriptions of petroleum exploration wells drilled in Georgia from 1979 to 1984.

### Non-metallic resources

#### Appalachian Plateau and Ridge and Valley provinces

**Geology**—These provinces (Fig. 1) of northwest Georgia are composed of folded Cambrian to Pennsylvanian carbonates, sandstones, shales, and cherts. At the eastern and southern border, Paleozoic strata are overthrust by igneous and metamorphic rocks of the Blue Ridge province along the Great Smoky-Cartersville fault. Cambrian and Mississippian limestone and shale are the major industrial minerals used for aggregate, cement, and for brick and tile manufacture. Ordovician slate was previously expanded for lightweight aggregate. Barite and iron-oxide pigments (ocher and umber) are mined from weathered Cambrian carbonate rocks in the Cartersville District. Bauxite, dolomite, fire clay, flagstone, and tripoli were previously mined in northwest Georgia. Barrett (1983) compiled an atlas of mines, prospects, and fossil localities in this area.

**Coal**—In the Appalachian Plateau (Fig. 2), Pennsylvanian coal typical of the Appalachian coal basin occurs predominantly in three counties in the northwestern corner of the state. Although most of the seams are thin and covered by thick sandstone overburden, some contain bituminous coal low in volatiles and ash and high in free-swelling indices, which makes a high-quality metallurgical or metallurgical-blend (Coleman et al., 1986a, b). Extensive coal mining in Georgia flourished through the 19th century but gradually declined during the first half of the 20th century, with the last surface mine closing in 1985. Coals in northwest Georgia were analyzed for ultimate and proximate values, calorific value, forms of sulfur, ash-fusion temperatures, free-swelling index, and more than 60 major, minor, and trace elements. Crawford (1989) mapped the geology of the Pennsylvanian system and coal-mine locations at a scale of 1:24,000.

**Manganese**—Herz (1989) evaluated the potential for high-grade, high-tonnage deposits in Lower Cambrian

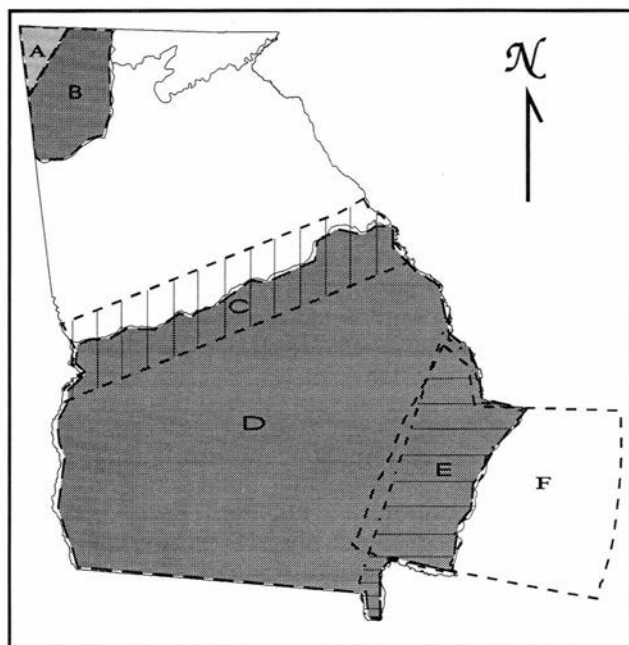

FIGURE 2—Locations of studies involving primarily sedimentary rocks. **A**, *Coal and clays*: Barrett, 1983; Coleman et al. 1986a, 1989; Crawford, 1989; O'Connor, 1985a, 1985b, 1985c, 1988d. **B**, *Magnesium carbonates and clays*: Barrett, 1983; Friddell, 1995; O'Connor, 1984, 1986, 1987, 1988a, b, c, 1989. **C**, *Fall Line stratigraphy and mapping*: Hetrick, 1990, 1992, in preparation; Hetrick and Friddell, 1990; Hetrick et al., 1987. **D**, *Construction materials and Coastal Plain stratigraphy*: Brackman, 1991; Friddell, 1987; Friddell and Brackman, 1987; Huddleston, 1988, 1993. **E**, *Heavy minerals*: Bonn and Simonson, 1991; Cocker, 1993b, c, d; Cocker and Shapiro, 1994. **F**, *Heavy minerals, phosphates, seismic stratigraphy, and offshore mining*: Cocker, 1993b; Grosz, 1993; Henry and Idris, 1992; Henry and Kellam, 1988; Herring et al., 1992; Kellam, 1986; Kellam and Henry, 1986, 1987; Kellam et al., 1988, 1992; Mannheim, 1992; Popenoe, 1992; Taylor et al., 1995; Zellars-Williams, 1988.

and Lower Mississippian carbonates in the Ridge and Valley province and Upper Cretaceous carbonates on the Coastal Plain province (Fig. 3). Manganese deposits in these carbonates do not have the characteristics of the major ocean anoxia, chemical-sedimentation model and are not believed to be economically significant (Herz, 1989).

**High-magnesium carbonates**—Friddell (1995) investigated the economic potential of the Cambrian-Ordovician Knox Dolomite, the Cambrian Shady Dolomite, and the Cambrian Conasauga Formation (Fig. 2). Abundant high-magnesium carbonates in the area are primarily suited for agricultural lime.

**Common clays**—Common clays in Georgia are an important source for the production of ceramic and structural-clay products, predominantly common brick and ceramic tile (O'Connor, 1989). Common-clay production in Georgia for 1992 was valued at over 15.3 million dollars (Sikich and O'Connor, 1994). The most significant deposits of these clays are located in the 10 northwestern counties (Fig. 2). These clays were formed by intense weathering of Paleozoic marine shales.

In the 19th century many companies mined common clay at numerous locations throughout Georgia. Several companies presently mine clay at scattered locations in the Ridge and Valley, Piedmont, and the northern edge of the Coastal Plain provinces (O'Connor, 1989).

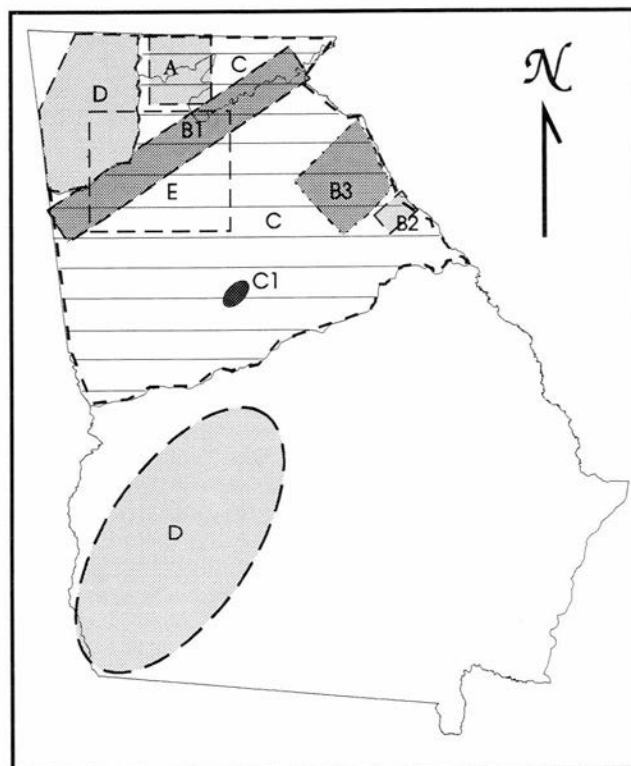

FIGURE 3—Locations of studies involving primarily metallic deposits. **A**, *Massive sulfides*: Abrams, 1986, 1987. **B**, *Volcanogenic gold*: (B1) Cook and Burnell, 1986; German, 1985, 1988, 1989, 1990, 1991; McConnell et al., 1986a, b; (B2) German, 1993; (B3) Hurst, 1990; Hurst et al., 1990; Allard and Whitney, 1994. **C**, *Platinum-group metals*: (C1) Cocker, 1995a; (C2) Higgins et al., 1992. **D**, *Sedimentary manganese*: Herz, 1989. **E**, *Greater Atlanta region (variety of metallic deposits)*: McConnell and Abrams, 1984.

O'Connor (1984, 1985a, b, c, 1986, 1987, 1988a, b, c, d) compiled all available ceramic firing tests and related analytical data on the ceramic and structural clays in the 10 northwestern counties.

### Piedmont and Blue Ridge provinces

**Geologic setting**—These provinces (Fig. 1) are composed of late Precambrian to Paleozoic igneous and metamorphic rocks (mostly gneisses, schists, and granites). Much of the bedrock in the Blue Ridge and Piedmont is blanketed with a thick residual-clay mantle (saprolite). Quaternary to Recent alluvium is common along the major drainages. These provinces are the sources of crushed and dimension stone (mostly granite and marble) as well as feldspar, scrap mica, residual clay (as structural clay for cement and brick), industrial sand, and talc. Alluvial clay, asbestos, beryl, corundum, kyanite, vein quartz, sheet mica, and soapstone have also been mined here. Two atlases of mines and prospects show the known mining localities for these provinces outside the Greater Atlanta area (Koch et al., 1984; Koch and Koch 1987).

**Granite and granite gneisses**—Georgia is among the leading producers of both crushed and dimension granite in the United States. The granite industry in Georgia is second only to the kaolin industry in its economic importance to the state. Vincent (1984) mapped the Siloam Granite (Fig. 4) in the Carolina terrane of the eastern Georgia Piedmont. Allard and Whitney (1994) mapped and compiled the Carolina terrane in east-central Georgia (Fig. 4) including the Elberton and Danburg granites



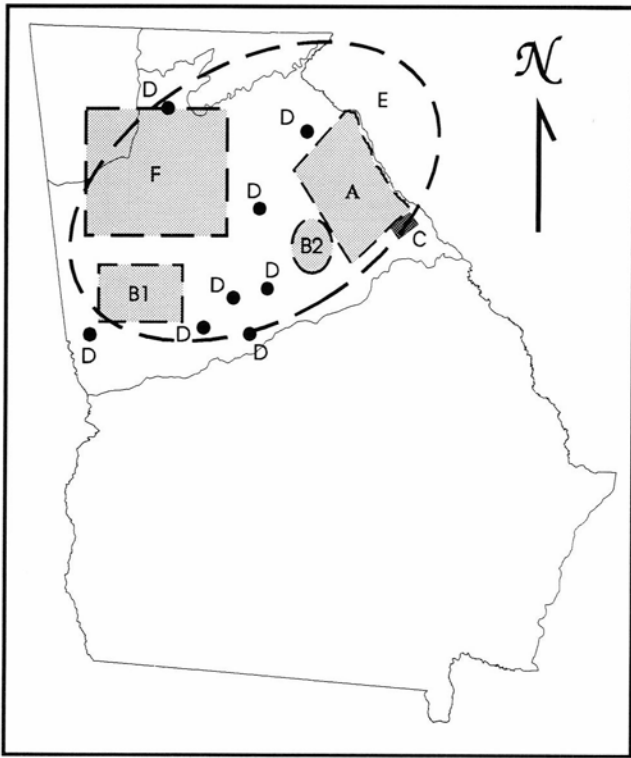

FIGURE 4—Locations of studies involving primarily igneous and metamorphic rocks. **A**, *Eastern Carolina terrane*: Allard and Whitney, 1994. **B**, *Granitic rocks*: (B1) Atkins and Lineback, 1992; (B2) Vincent, 1984. **C**, *Talc, serpentinite, rare-earth elements*: Cocker, 1989a, b, c, 1990, 1991a, 1992b, c. **D**, *Pegmatites*: Gunow and Bonn, 1989; Gunow et al., 1992; Cocker, 1991b, 1992a, d, e, 1993a, 1994, 1995a. **E**, *High-magnesium silicate rocks*: Vincent et al., 1990. **F**, *Greater Atlanta region (variety of igneous and metamorphic rocks)*: McConnell and Abrams, 1984.

and several metagranitic plutons. Atkins and Lineback (1992) mapped the Cedar Rock complex, an extensive metagranitic unit in the Inner Piedmont south of Atlanta (Fig. 4).

**High-magnesium silicate rocks**—In addition to dolomites, other sources of magnesium are metamorphosed and altered ultramafic and mafic igneous rocks (including dunite, soapstone, talc, and serpentinite). These rocks are used for producing refractory material, primarily for bricks to line furnaces in the iron and steel industry. Vincent et al. (1990) located and described 27 of the many mafic and ultramafic rock units found in Georgia. Descriptions include thin-section analyses and whole-rock geochemistry of the least-altered rock units. This study provides a modern overview of these types of occurrences and detailed location maps (Fig. 4).

**Talc**—Cocker (1989a, b, c, 1991a, 1992a, b) described the geologic setting, rock types, rock chemistry, and origin of altered serpentinites of the Burks Mountain complex in the southeastern Piedmont (Fig. 4). The Burks Mountain complex contains potentially economic deposits of talc, titanium, vanadium, and rare earths. This study revealed a body of talc at a grade of 25% and an estimated resource of 7.3 million tons. The serpentinite host rock was defined by detailed mapping, a ground magnetic survey, and core drilling. The talc deposit is near the surface and could be mined by open-pit methods. Drill cores also contain significant intervals of unweathered, massive serpentinite that may be suitable for use as dimension stone and other industrial purposes.

**Rare-earth elements**—Iron-oxide minerals enriched in rare-earth elements, titanium, and vanadium are also found within the Burks Mountain complex (Fig. 4). Cocker (1990, 1992c) described the mineralogy, textures, and geochemistry of this unique occurrence. This mineralization was discovered as the result of mapping near the Burks Mountain talc body.

**Pegmatites**—In Georgia, pegmatites have been important sources of sheet and scrap mica, feldspar, and beryl. Mica is widely used as a filler, coating agent, and in electronics. Feldspar is a major component of many fired ceramics. Beryl is used in special high-temperature ceramics and in electronics. Pegmatites are potentially important sources for strategic and critical elements such as beryllium, niobium, tantalum, lithium, and a variety of rare-earth elements. Re-examination of the distribution, geochemistry, and petrogenesis of pegmatites in Georgia identified particular pegmatite bodies and districts as having greater potential for containing rare metals (Gunow and Bonn, 1989; Gunow et al., 1992; Cocker, 1991b, 1992d, e, f, 1993a, 1994, 1995b). Each pegmatite mine and pegmatite body was located in the field on 1:24,000 topographic maps, and these locations are in several Geographic Information System (GIS) databases. Additional geochemical data from other districts (Cocker, unpublished data) are on file at the Georgia Geologic Survey. Gunow and Bonn (1989) and Cocker (1991b, 1992d, e, f, 1993a, 1994, 1995b) demonstrated the value of geochemical data and techniques used for evaluating the pegmatites in the extreme weathering conditions of the Piedmont and Blue Ridge of Georgia.

Gunow and Bonn (1989), Gunow et al. (1992), and Cocker (1994, 1995b) examined the geochemistry and mineralogy of several relatively unknown districts (Cherokee–Pickens, Thomaston–Barnesville, Jasper County, and Troup County; Fig. 4). Gunow et al. (1992) provided subsurface lithologic and geochemical details from five core holes in the Cochran Pegmatite mine. A study of the Jasper County pegmatite district in the central Piedmont shows that pegmatites in the northern third of the district may be enriched in rare-metal-bearing minerals (Cocker, 1992g, 1995b) and that large areas in Jasper County have a high potential for additional feldspar-rich pegmatites. The pegmatitic feldspar is used in ceramics, pottery, glass, and latex filler. District-scale geochemical and mineralogical zoning was defined for the Thomaston–Barnesville district, which was the largest producer of sheet mica in the southeastern United States during World War II. This zoning indicates that the greatest potential for rare-metal-bearing pegmatites is in the central part of the district (Cocker, 1991b, 1992e).

### Coastal Plain and Continental Shelf provinces

**Geologic setting**—The Coastal Plain occupies the southern two-thirds of the state and is composed of poorly consolidated sediments (predominantly clays, sands, and marls) that range from Cretaceous to Holocene in age. These strata are essentially undeformed and dip very gently toward the coast to the south and southeast. The sediments are the source for most of Georgia's various clays (bauxite, fuller's earth, kaolin, and structural clay) as well as construction sand and gravel, industrial sand, soft limestone (for aggregate and cement), and minor horticultural peat. Weathered Pleistocene barrier-island sands in the southeastern corner of the state have been mined for heavy-mineral sands (ilmenite, leucoxene, monazite,

staurolite, rutile, and zircon). Atlases of mines and prospects (Koch and Koch, 1989; Kellam, 1986) provide summaries of mining localities for the Coastal Plain province.

Huddleston (1993) described the regional stratigraphy, structure, and paleontology of the Oligocene sediments of south Georgia (Fig. 2). These strata form the framework for part of the upper Floridan aquifer, which is the major source of drinking water in coastal Georgia and a critical ground-water resource for Georgia, Florida, Alabama, and South Carolina. That report provides the basis for predicting the hydrologic properties of the aquifer over large regions. The Gulf trough, the largest structural feature in the subsurface of south Georgia, is a major impediment to the flow of ground water from the recharge areas of the Floridan aquifer (Huddleston, 1993).

**General—The Georgia Geologic Survey** developed a GIS under a grant from the U.S. Minerals Management Service (Cocker, 1993c). This GIS will be an important tool for resource management along the Georgia coast. Several maps were generated which demonstrate the relationship between offshore active bottoms and areas of erosion on the Continental Shelf (Cocker, 1993b)—this relationship had not been previously identified. An assessment of environmental research containing a computer database of approximately 2,500 references covers potential biological, chemical, geologic, and oceanographic effects of offshore mining relevant to the Georgia Continental Shelf (Taylor et al., 1995).

Koch (1988) showed the distribution of various metals in stream sediments collected during the U.S. Department of Energy's NURE program. Of particular interest are maps showing the distribution of uranium, thorium, rare-earth elements, aluminum, pH, conductivity, and alkalinity. These are useful for heavy-mineral and kaolin studies.

**Heavy-mineral sands—In** the Coastal Plain and Continental Shelf of Georgia and other Atlantic states, heavy minerals are concentrated in placer deposits associated with major river systems and major beach deposits. Heavy-mineral beach deposits are principally associated with Pleistocene, Holocene, and perhaps Pliocene shorelines (Kellam et al., 1992; Cocker, 1993c; Cocker and Shapiro, 1994). Older placer deposits associated with Cretaceous and Eocene sands near the Fall Line are suggested by the NURE geochemical maps in Koch (1988). Zellars-Williams (1988) and Grosz (1993) described the abundance and distribution of heavy minerals in samples from offshore Georgia. Extensive sampling of Pleistocene deposits covers much of the southeastern Coastal Plain of Georgia (Kellam et al., 1992). Detailed sampling in and adjacent to the Altamaha River delta is documented by Bonn and Simonson (1991) and Kellam et al. (1992). These earlier studies are summarized by Shapiro and Bonn (1990) and Cocker and Shapiro (1994).

Cocker (1993c, 1993d) re-examined the heavy-mineral data and analyzed the variation in mineralogy between various Pleistocene and Holocene beach deposits and offshore samples, and used the data (1993d) to develop a model for deposition and concentration of heavy minerals into economic shoreline deposits. Cocker (1993b) incorporated all of the previously published coastal data into a computer-based GIS.

**Construction aggregate—Construction** aggregate on the Coastal Plain includes sand and gravel deposits that can be modified to meet ASTM standards for fine and

coarse aggregate. Because coarse aggregate must currently be transported to Coastal Plain construction sites from the Fall Line area or the Piedmont, construction costs are increased significantly. Friddell (1987), Friddell and Brackman (1987), and Brackman (1991) located, described, sampled, analyzed, and evaluated deposits of aggregate with potential reserves of at least 100,000 yds<sup>3</sup>.

Friddell (1987) identified seven areas in the western third of the Coastal Plain that have a high potential for the production of coarse construction aggregate. Friddell and Brackman (1987) identified one area in the eastern third of the Coastal Plain with a moderate potential for limited production of coarse construction aggregate and seven areas with high to moderate potential for the production of fine aggregate. Brackman (1991) located 148 sites in the central third of the Coastal Plain as having some potential for aggregate production (Fig. 2).

**Phosphate—Large** Miocene phosphate deposits occur in the Waycross Basin in the eastern part of the Georgia Coastal Plain and on the adjacent Continental Shelf (Fig. 2). The bulk of the phosphate is in the Tybee Phosphorite Member of the Hawthorne Group. Henry and Idris (1992), Henry and Kellam, (1988), Herring et al. (1992), Kellam and Henry (1986, 1987), Kellam (1986), Kellam et al. (1988), Mannheim (1992), and Popenoe (1992) mapped and described the regional stratigraphy using seismic surveys and core drilling. Herring et al. (1992) and Mannheim (1992) provided mineralogical and chemical analyses of drill cores from the phosphate deposits.

**Kaolin—Cretaceous** and Early Tertiary sediments immediately south of the Fall Line (Figs. 1, 2) host several world-class kaolin-producing districts and are an area of significant recharge for the Floridan aquifer system. Ongoing mapping and stratigraphic studies (Hetrick et al., 1987; Hetrick, 1990, 1992, in preparation; Hetrick and Friddell, 1990; Huddleston, 1993) are part of a long-range effort to perform detailed geological mapping of the entire Fall Line ground-water-recharge zone. These studies provide important geologic information for mineral exploration, hydrologic investigations, ground-water modelling, and regional planning of orderly development and utilization of natural resources and the location of landfills, roads, and industrial sites. This mapping has expanded our knowledge of the stratigraphic framework and geologic history of the region. Mapping at 1:24,000 and compiled at 1:100,000 was completed for four adjoining regions along the Fall Line: Fort Valley (Hetrick, 1990), Wrens (Hetrick, 1992), Macon-Sandersville (Hetrick and Friddell, 1990), and Butler (Hetrick, in preparation).

The most recent study in the Butler area suggests the presence of major faulting or other tectonic displacement of sediments along the Flint River. The effect of such displacement on ground-water supplies remains to be investigated. Current mapping in the Valdosta area will continue this series of studies of the Fall Line stratigraphy and recharge zone.

## Metallic resources

### General

Volcanogenic base-metal, massive-sulfide and related vein- and disseminated-gold deposits occur within several belts of the Piedmont and Blue Ridge. Residual iron ore and barite overlying Knox Group carbonates in the Ridge and Valley may be weathered residuum of Mississippi Valley-type sulfides, fluorite, and barite mineralization.

**Volcanogenic massive sulfides**—Massive-sulfide deposits in Georgia may consist of veins or layers of pyrite, pyrrhotite, and chalcopyrite with minor amounts of gold, galena, and sphalerite. Several such deposits were mined for the production of sulfuric acid. Abrams (1986, 1987) identified and mapped a geologic marker horizon south from the massive-sulfide deposits of Ducktown, Tennessee, and evaluated drill-core and geochemical data in that area (Fig. 4).

McConnell and Abrams (1984) mapped and compiled the geology and many mineral deposits of the Greater Atlanta region (Fig. 4) and discussed the massive-sulfide deposits of the western Piedmont of Georgia. Allard and Whitney (1994) mapped and compiled the geology of the volcanogenic Carolina terrane in eastern Georgia (Fig. 4). The numerous sulfide deposits, including the pyritiferous kyanite deposit at Graves Mountain, are placed within the context of the volcanogenic terrane.

**Mississippi Valley-type sulfides**—The potential for Mississippi Valley-type sulfides in the Knox Dolomite of Polk County, northwest Georgia, was examined with 23 core holes (total of 11,800 ft), numerous thin-sections, and field studies. Results suggest that residual iron-ore deposits of northwest Georgia may be weathered sulfide deposits. Trace galena, fluorite, and barite mineralization was found in the field (Fig. 3); however, no economic mineralization was discovered. Chowns (1993, 1994) and Chowns and O'Connor (1992) obtained important local and regional stratigraphic information on the Knox Dolomite from the drill cores, as well as petrographic and field studies.

**Gold**—Two major gold-producing areas were subjects of several studies that included modern 7.5 minute quadrangle-scale mapping (published at 1:100,000). McConnell et al. (1986a, b) and German (1985, 1988, 1989, 1990, 1991) examined in detail the geology, structure, mineralogy, and geochemistry of the gold-bearing volcanogenic deposits in the Dahlonga belt (Fig. 3). German (1990) completed petrographic and geochemical studies of core holes into a pyrite-rich (up to 50% pyrite) sericite-quartz schist body in the Dahlonga district. Cook et al. (1984) prepared a geologic map of the Dahlonga district. Cook et al. (1986) studied the trace-element signatures of several lithologic units in that district. Allard and Whitney (1994) synthesized the geology of the eastern part of the Carolina terrane in Georgia (Fig. 3) and placed the many volcanogenic base- and precious-metal deposits in the context of the evolution of these rocks. Hurst (1990) and Hurst et al. (1990) compiled the geology in east-central Georgia and conducted a geochemical reconnaissance for gold. German (1993) also prepared a detailed geologic map and evaluation of the McDuffie County gold belt in the southeastern Piedmont province (Fig. 3), a relatively unknown but historically important gold mining district.

**Platinum**—Platinum may occur with other precious metals such as iridium, rhodium, palladium, osmium, and ruthenium either in ultramafic rocks or in placer deposits. Higgins et al. (1992) investigated the platinum-group-metal potential of the Blue Ridge and Piedmont provinces (Fig. 3). Based on their whole-rock major and trace-element chemical analyses of 169 mafic and ultramafic rocks, the Gladesville layered mafic intrusion was considered to have the highest potential for hosting economic concentrations of platinum-group metals.

Cocker (1995a) described base- and precious-metal-enrichment trends in a 1,000 ft core hole drilled in the

early 1970s in the Gladesville layered mafic intrusion (Fig. 3). The drill hole consists mainly of steeply dipping layers of norite, anorthosite, and olivine gabbro that are cut by diabase dikes and numerous feldspar-rich pegmatites. Correlation of these metal-enrichment trends with enrichment of the volatiles CO<sub>2</sub> and S and with increased amounts of olivine gabbro suggests differentiation trends similar to those in the Stillwater complex in Montana, which is a major source of platinum and palladium.

#### Use in economic and environmental studies

The population of Georgia has grown significantly during the past several decades and is currently undergoing a major surge spurred in part by the 1996 Olympic Games in Atlanta. Georgia is currently ranked 11th in population and is expected to be among the 10 most-populous states in a few years. Principal areas of growth are in and adjacent to the Atlanta metropolitan area, Athens, Augusta, Columbus, Chattanooga (Tennessee), Savannah, Brunswick, and Macon. Construction material for housing, industry, and transportation is more abundant in the Piedmont and Ridge and Valley provinces than in the Coastal Plain. Investigation of the sand and gravel deposits on the Coastal Plain provides data with which the cost and direction of growth can be planned.

Data obtained during the AEMP and subsequent studies should be helpful in a variety of environmental and economic investigations. Some of the more important environmental issues that Georgia needs to address include: feasibility of and guidelines for offshore mining; guidelines for protection of aquifers along the Fall Line, shallow coastal aquifers and deeper aquifers that extend offshore; fracture-controlled aquifers in the Piedmont and Blue Ridge; carbonate aquifers in the Ridge and Valley; regional reservoirs in the Ridge and Valley, Piedmont, and Blue Ridge provinces; water-quality planning and river-basin management; wildlife and commercial-fisheries habitat protection; landfill siting; mineral-resource planning, development, and remediation.

In Georgia, increasing public awareness and need have focussed more attention on ground-water and surface-water quality. The location of Augusta, Macon, and Columbus and the kaolin mines in the principal recharge zone of the Floridan aquifer require careful planning of development of both population centers and mineral resources. Exceptional growth of Savannah and Brunswick has added considerable stress to the aquifer in the Miocene strata. Salt-water incursion is increasing in this aquifer because of increasing drawdown from wells. Offshore mining of phosphate in the Miocene strata could exacerbate that problem. Continued outward growth from Chattanooga and smaller cities in the Ridge and Valley province will increase the need for aquifer protection and perhaps the likelihood of a major regional reservoir. Increased water withdrawal in carbonate aquifers will increase the potential for sinkhole development. Location and composition of numerous sulfide mines and occurrences may affect water quality either downstream or in proposed reservoirs. Kaolin mining and processing may also affect water quality.

Several other less well-known environmental issues may affect mineral development in Georgia. For example, maintenance of air quality around crushed-stone operations in metropolitan areas is a major concern. Industrial-mineral development may encounter problems

associated with protection of wildlife habitats both on-shore and offshore. Certain endangered plants are found only on particular granite or serpentinite pavements. Offshore hardgrounds are critical habitats for sport and commercial fish. Also whales, turtles, and manatees may be affected by coastal or offshore mineral development.

### Summary

The AEMP and subsequent projects increased the general and detailed geologic databases for a wide variety of industrial- and metallic-mineral deposits in Georgia. Roughly 100 publications document the geology, mineralogy, geochemistry, and geophysics of these mineral deposits as well as surrounding areas. Core drilling has provided a wealth of subsurface information on the mineral deposits and surrounding geologic units. Geologic mapping ranged in scale from outcrop to 1:100,000 compilations. The variety and extent of information discussed in this paper should provide an important database upon which mineral exploration may be developed.

The geology, mineralogy, geochemistry, geophysics, and down-hole data acquired during the AEMP should prove valuable in economic and environmental studies. Rapid growth of Georgia's population out from major cities will increase environmental pressures on undeveloped or environmentally sensitive areas. This growth will lead to increased industrial-mineral requirements that may be in conflict with that growth. That conflict may be direct as in cases of crushed-stone quarries versus subdivisions, or indirect such as mineral development in critical aquifer-recharge areas. The numerous maps produced in the AEMP program should be of benefit for local and regional planning agencies to incorporate both growth of the population and necessary industrial-mineral development. Studies of the mineralogy, geochemistry, geophysics, and down-hole data provide the details for the mineral and environmental studies. The wealth of new data generated by the AEMP will help shape decisions regarding regional planning, mineral development, and environmental protection.

### Acknowledgments

The authors wish to thank Robin McDowell and Earl Shapiro of the Georgia Geologic Survey for their review of an early draft of this manuscript.

### References

- Abrams, C. E., 1986, Base metal mines of the southwest Ducktown District, Georgia; *in* Misra, K. C. (ed.), Volcanogenic sulfide and precious metal mineralization in the southern Appalachians: University of Tennessee, Department of Geological Science, Studies in Geology 16, pp. 78-96.
- Abrams, C. E., 1987, Base metal mines and prospects of the southwest Ducktown District, Georgia: Georgia Geologic Survey, Information Circular 78, 61 pp.
- Allard, G. O., and Whitney, J. A., 1994, Geology of the Inner Piedmont, Carolina terrane, and Modoc zone in northeast Georgia: Georgia Geologic Survey, Project Report 20, 36 pp.
- Atkins, R. L., and Lineback, J. A., 1992, Structural relations, origin and emplacement of granitic rocks in the Cedar Rock complex, Georgia Piedmont: Georgia Geologic Survey, Bulletin 115, 40 pp.
- Bonn, G. N., and Simonson, D. N., 1991, Evaluation of heavy mineral-bearing nearshore sand, Altamaha Sound, and the adjacent nearshore, Georgia: Georgia Geologic Survey, Open-file Report 90-3, 160 pp.
- Barrett, J. S., 1983, Geologic atlas of northwest Georgia: Georgia Geologic Survey, Open-file Atlas, scale 1:24,000, 77 maps.
- Brackman, J. S., 1991, Construction material potential of the middle Georgia Coastal Plain- An evaluation: Georgia Geologic Survey, Bulletin 108, 228 pp.
- Chowns, T. M., 1993, Depositional environments and diagenetic history of the upper Knox Group in core holes from near Cedartwon, Polk County, Georgia: Georgia Geologic Survey, [Unpublished report], 150 pp.
- Chowns, T. M., 1994, Stratigraphy of the Knox Group in core holes from near Cedartwon, Polk County, Georgia: Georgia Geologic Survey, [Unpublished report], 98 pp.
- Chowns, T. M., and O'Connor, B. J. (eds.), 1992, Cambro-Ordovician stratigraphy in northwest Georgia and southeast Tennessee-The Knox Group and the Sequatchie Formation: Georgia Geologic Survey, Guidebooks, v. 12, no. 1, 156 pp.
- Cocker, M. D., 1989a, Talc alteration of a serpentinite in the Burks Mountain ultramafic complex, Columbia County, Georgia (abs.): Geological Society of America, Abstracts with programs, v. 20, no. 2, p. 8.
- Cocker, M. D., 1989b, Metamorphism and deformation of the Burks Mountain ultramafic complex, Columbia County, Georgia (abs.): Geological Society of America, Abstracts with programs, v. 20, no. 2, p. 8.
- Cocker, M. D., 1989c, Geochemistry of a vertically zoned, metamorphosed and serpentinitized harzburgite, implications for the tectonic evolution of the southern Appalachian Piedmont (abs.): Geological Society of America, Abstracts with programs, v. 20, no. 7, p. 106.
- Cocker, M. D., 1990, Mineralogy, geochemistry and genesis of REE-Ti-V enriched iron oxides in the Burks Mountain complex, Columbia County, Georgia (abs.): Geological Society of America, Abstracts with programs, v. 22, no. 4, p. 8.
- Cocker, M. D., 1991a, Geology and origin of a talc prospect in the Burks Mountain complex, Columbia County, Georgia; *in* Pickering, S. M., Jr. (ed.), Proceedings of the symposium on the economic geology of the southeastern industrial minerals: Georgia Geologic Survey, Bulletin 120, pp. 107-133.
- Cocker, M. D., 1991b, Geochemical zoning in muscovites from the Thomaston-Barnesville pegmatite district, Georgia (abs.): Geological Society of America, Abstracts with programs, v. 23, no. 1, p. 17.
- Cocker, M. D., 1992a, Economic geology of altered serpentinites in the Burks Mountain complex, Columbia County, Georgia: Georgia Geologic Survey, Bulletin 123, 89 pp.
- Cocker, M. D., 1992b, Geology and geochemistry of altered serpentinites in the Burks Mountain complex, Columbia County, Georgia: Georgia Geologic Survey, Bulletin 124, 112 pp.
- Cocker, M. D., 1992c, Mineralogy, geochemistry and genesis of REE-Ti-V enriched iron oxides in the Burks Mountain complex, Columbia County, Georgia; *in* Rheams, K. F., and McClellan, G. H. (eds.), Industrial minerals of the southeastern United States-Proceedings of the 2nd annual symposium on industrial minerals: Alabama Geological Survey, Circular 161, pp. 77-89.
- Cocker, M. D., 1992d, Pegmatite investigations in Georgia; *in* Sweet, P. C. (ed.), Proceedings of the 26th Annual Forum on the Geology of industrial minerals: Virginia Department of Mines, Minerals and Energy, Division of Mineral Resources, Publication 119, pp. 103-111.
- Cocker, M. D., 1992e, Muscovite geochemistry and rare-metal potential of pegmatites in the Thomaston-Barnesville district, Georgia (abs.): Geological Society of America, Abstracts with programs, v. 24, no. 2, p. 9.
- Cocker, M. D., 1992f, Enrichment of trace elements in rare-metal bearing pegmatites of the muscovite class: Examples from the Jasper, Thomaston-Barnesville, Troup and Cherokee-Pickens districts in Georgia (abs.): Geological Society of America, Abstracts with programs, v. 24, no. 7, p. A216.
- Cocker, M. D., 1993a, Geochemistry and economic potential of pegmatites in the Thomaston-Barnesville district, Georgia: Georgia Geologic Survey, Geologic Report 7, 81 pp.
- Cocker, M. D., 1993b, Report on the Georgia Coastal Geographic Information System: Georgia Geologic Survey, Open-file Report 93-1, 19 pp.

- Cocker, M. D., 1993c, Relation of heavy mineral suites to Pleistocene to Holocene shoreline sequences in Georgia (abs.): Geological Society of America, Abstracts with programs, v. 25, no. 4, p. 9.
- Cocker, M. D., 1993d, A model for heavy mineral deposit formation within Pleistocene to Holocene shoreline sequences in Georgia (abs.): Geological Society of America, Abstracts with programs, v. 25, no. 4, p. 9.
- Cocker, M. D., 1994, Muscovite geochemistry and rare-metal potential of pegmatites in the Troup County pegmatite district, Georgia (abs.): Geological Society of America, Abstracts with programs, v. 26, no. 4, p. 8.
- Cocker, M. D., 1995a, Base- and precious-metal and major-element trends in the Gladesville layered mafic intrusion, Jasper County, Georgia (abs.): Geological Society of America Abstracts with programs, v. 27, no. 2, p. 44.
- Cocker, M. D., 1995b, Geological setting and geochemical trends in the Jasper County pegmatite district, Georgia; *in* Walker, B. J. (ed.), Proceedings of the 28th Annual Forum on the Geology of the Industrial Minerals: West Virginia Geological and Economic Survey and U.S. Bureau of Mines, Circular 46, pp. 85-94.
- Cocker, M. D., and Shapiro, E. A., 1994, Distribution of heavy minerals on the Georgia Coastal Plain and Continental Shelf; *in* Dellagiarino, G., Masterson, A. R., and Miller, L. A. (eds.), Proceedings of the third symposium on studies related to continental margins—A summary of year-five and year-six activities: Minerals Management Service, Continental Margins Committee, Association of American State Geologists, and University of Texas (Austin), Bureau of Economic Geology, pp. 55-61.
- Coleman, S. L., Crawford, T. J., and Medlin, J. H., 1986a, Quality of coal resources underlying Sand and Lookout Mountains in Georgia and Alabama: Georgia Geologic Survey, Bulletin 102, 75 pp.
- Coleman, S. L., Crawford, T. J., and Medlin, J. H., 1986b, Analyses of coal from northwest Georgia: Georgia Geologic Survey, Information Circular 76, 321 pp.
- Cook, R. B., Jr., Burnell, J. R., Jr., and Sibley, D. E., 1984, Preliminary geologic map of the Dahlonga district, Georgia: Georgia Geologic Survey, Open-file Report 85-3, 1:24,000 map.
- Cook, R. B., Jr., and Burnell, J. R., Jr., 1986, The trace element signature of some major lithologic units, Dahlonga district, Lumpkin County, Georgia; *in* Misra, K. C. (ed.), Volcanogenic sulfide and precious metal mineralization in the southern Appalachians: University of Tennessee, Department of Geological Science, Studies in Geology 16, pp. 206-219.
- Crawford, T. J., 1989, Geology of the Pennsylvanian System of Georgia: Georgia Geologic Survey, Geologic Atlas 2, 16 plates., scale 1:24,000.
- Friddell, M. S., 1987, Construction material potential of the Coastal Plain of southwestern Georgia: Georgia Geologic Survey, Bulletin 106, 253 pp.
- Friddell, M. S., 1995, High magnesium limestones and dolostones of northwest Georgia: Georgia Geologic Survey, Bulletin 126, 53 pp.
- Friddell, M. S., and Brackman, J. S., 1987, Construction material potential of the eastern Georgia Coastal Plain—An evaluation: Georgia Geologic Survey, Bulletin 108, 239 pp.
- German, J. M., 1985, Geology of the northeastern portion of the Dahlonga gold belt: Georgia Geologic Survey, Bulletin 100, 41 pp.
- German, J. M., 1988, The geology of gold occurrences in the west-central Georgia Piedmont: Georgia Geologic Survey, Bulletin 107, 48 pp.
- German, J. M., 1989, Geologic setting and genesis of gold deposits of the Dahlonga and Carroll County gold belts, Georgia: Economic Geology, v. 84, pp. 903-923.
- German, J. M., 1990, Stratigraphic implications from core drilling in the vicinity of the Royal Vindicator gold mine, Haralson County, Georgia: Georgia Geologic Survey, Information Circular 84, 19 pp.
- German, J. M., 1991, A petrologic and economic study of a hydrothermal alteration zone in Lumpkin County, Georgia: Georgia Geologic Survey, Information Circular 89, 34 pp.
- German, J. M., 1993, Geology of the McDuffie County gold belt: Georgia Geologic Survey, Bulletin 125, 59 pp.
- Grosz, A. E., 1993, Mineralogy and heavy-mineral resource potential of surficial sediments on the Atlantic Continental Shelf offshore of Georgia: Georgia Geologic Survey, Project Report 19, 31 pp.
- Gunow, A. J., and Bonn, G. N., 1989, Mica geochemistry and origin of pegmatites, Cherokee-Pickens district, Georgia: Georgia Geologic Survey, Bulletin 103, 93 pp.
- Gunow, A. J., Bonn, G. N., and O'Connor, B. J., 1992, Subsurface geology of the Cochran Pegmatite, Cherokee-Pickens district, Georgia: Georgia Geologic Survey, Geologic Report 5, 27 pp.
- Henry, V. J., and Idris, F. M., 1992, Offshore minerals assessment studies of the Georgia Continental Shelf—Phase 2: Seismic stratigraphy of the TACTS area and evaluation of selected sites for economic hard minerals potential: Georgia Geologic Survey, Project Report 18, 143 pp.
- Henry, V. J., Jr., and Kellam, J. A., 1988, Seismic investigation of the phosphate-bearing, Miocene-age strata of the Continental Shelf of Georgia: Georgia Geologic Survey, Bulletin 109, 43 pp.
- Herring, J. R., Mannheim, F. T., Farrell, K. M., Huddleston, P. F., and Bretz, B., 1992, Size analysis, visual estimation of phosphate and other minerals, and preliminary estimation of recoverable phosphate in size fraction of sediment samples from drill holes GAT-90, Tybee Island and GAS 90-2, Skidaway Island, Georgia: Georgia Geologic Survey, Project Report 16, 36 pp.
- Herz, N., 1989, Evaluation of the manganese resources of Georgia: Georgia Geologic Survey, [Unpublished report], 31 pp.
- Hetrick, J. H., 1990, Geologic atlas of the Fort Valley area: Georgia Geologic Survey, Geologic Atlas 7, 2 plates., scale 1:100,000.
- Hetrick, J. H., 1992, Geologic atlas of the Wrens-Augusta area: Georgia Geologic Survey, Geologic Atlas 8, 3 plates., scale 1:100,000.
- Hetrick, J. H., in preparation, Geologic atlas of the Butler area: Georgia Geologic Survey, Geologic Atlas 9, scale 1:100,000.
- Hetrick, J. H., and Friddell, M. S., 1990, A geologic atlas of the central Georgia kaolin district: Georgia Geologic Survey, Geologic Atlas 6, 4 plates., scale 1:100,000.
- Hetrick, J. H., Friddell, M. S., and Weaver, C. E., 1987, Clay mineralogy of the Hawthorne Group: Georgia Geologic Survey, Information Circular 79, 102 pp.
- Higgins, M. W., Crawford, T. J., Lesure, F. G., Nelson, A. E., Grossman, M. W., Doughten, N. R., McCartan, L., Crawford, R. F., III, Medlin, J. H., Gotfried, D., Cook, R. B., Jr., Sanders, R. P., and Gillon, K. A., 1992, A preliminary geochemical evaluation of potential for platinum deposits in the crystalline rocks of Georgia: U.S. Geological Survey, Open-file Report 92-220, 89 pp.
- Huddleston, P. F., 1988, A revision of the lithostratigraphic units of the Coastal Plain of Georgia—The Miocene through the Holocene: Georgia Geologic Survey, Bulletin B-104, 162 pp.
- Huddleston, P. F., 1993, A revision of the lithostratigraphic units of the Coastal Plain of Georgia—The Oligocene: Georgia Geologic Survey, Bulletin B-105, 152 pp.
- Hurst, V. J., 1990, Gold in east-central Georgia: Georgia Geologic Survey, Bulletin B-112, 60 pp.
- Hurst, V. J., Kremmer, T., and Bush, P. B., 1990, Geochemical reconnaissance for gold in east-central Georgia: Georgia Geologic Survey, Information Circular 83, 23 pp.
- Kellam, M. F. (ed.), 1986, Geologic atlas of Coastal Georgia: Georgia Geologic Survey, Geologic Atlas 5, scale 1:249,285.
- Kellam, J. A., Bonn, G. N., and Laney, M. L., 1992, Distribution of heavy mineral sands adjacent to the Altamaha Sound—A possible exploration model: Georgia Geologic Survey, Bulletin 110, 61 pp.
- Kellam, J. A., and Henry, V. J., 1986, Interpretation of the seismic stratigraphy of the phosphatic middle Miocene on the Georgia Continental Shelf: Georgia Geologic Survey, Geologic Atlas 4, 9 plates., scale 1:449,659.

- Kellam, J. A., and Henry, V. J., 1987, Seismic investigation of the Tybee Trough area; Georgia/South Carolina: Southeastern Geology, v. 28, no. 2, pp. 65-80.
- Kellam, J. A., Shapiro, E. A., and Henry, V. J., 1988, Mineral resource assessments for the Continental Shelf of Georgia as a part of the Continental Margins Study Program; *in* Hunt, M. C., Ratcliff, D. C., Doenges, S., and Condon, C. (eds.), Proceedings of the First symposium on studies related to continental margins-A summary of year-one and year-two activities: Minerals Management Service, Continental Margins Committee, Association of American State Geologists, and University of Texas (Austin), Bureau of Economic Geology, pp. 124-137.
- Kellam, J. A., Mallary, M., McKenzie, M., and Laney, M. L., 1992, Heavy mineral-bearing sands from the Wicomico to the Princess Anne barrier complexes along the Georgia Coastal Plain: Georgia Geologic Survey, Bulletin 111, 50 pp.
- Koch, G. S., 1988, A geochemical atlas of Georgia: Georgia Geologic Survey, Geologic Atlas 3, scale 1:1,785,000.
- Koch, G. S., and Koch, R. S., 1987, Geologic atlas of Georgia-A second atlas of mine workings, quarries, and prospects in part of northern Georgia: Georgia Geologic Survey, Open-file Atlas, scale 1:24,000.
- Koch, G. S., and Koch, R. S., 1989, An atlas of mine workings and quarries in the Coastal Plane of Georgia: Georgia Geologic Survey, Open-file Atlas, scale 1:24,000, 84 maps.
- Koch, G. S., Koch, R. S., and Kapatov, A., 1984, Geologic atlas of Georgia-An atlas of mine workings, quarries and prospects in part of northern Georgia: Georgia Geologic Survey, Open-file Atlas, scale 1:24,000, 211 maps.
- Mannheim, F. T., (ed.), 1992, Geology, stratigraphic relationships, and chemical composition of phosphatic drill cores (TACTS boreholes) from the Continental Shelf off Georgia: Georgia Geologic Survey, Project Report 17, 47 pp.
- McConnell, K. I., and Abrams, C. E., 1984, Geology of the greater Atlanta region: Georgia Geologic Survey, Bulletin 96, 127 pp.
- McConnell, K. I., Abrams, C. E., and German, J. M., 1986a, Gold deposits in the northern Piedmont of Georgia and Alabama and their relationship to lithostratigraphic units; *in* Misra, K.C. (ed.), Volcanogenic sulfide and precious metal mineralization in the southern Appalachians: University of Tennessee, Department of Geological Science, Studies in Geology 16, pp. 164-181.
- McConnell, K. I., German, J. M., and Abrams, C. E., 1986b, Gold and base metal mineralization host rocks in the Dahlonga and Carroll County gold belts, Georgia: Georgia Geological Society, Guidebooks, v. 6, no. 5, 120 pp.
- O'Connor, B. J., 1984, Ceramic and structural clays of Bartow County, Georgia: Georgia Geologic Survey, Information Circular 64, 163 pp.
- O'Connor, B. J., 1985a, Ceramic and structural clays of Catoosa County, Georgia: Georgia Geologic Survey, Information Circular 65, 46 pp.
- O'Connor, B. J., 1985b, Ceramic and structural clays of Chattooga County, Georgia: Georgia Geologic Survey, Information Circular 66, 83 pp.
- O'Connor, B. J., 1985c, Ceramic and structural clays of Dade County, Georgia: Georgia Geologic Survey, Information Circular 67, 68 pp.
- O'Connor, B. J., 1986, Ceramic and structural clays of Floyd County, Georgia: Georgia Geologic Survey, Information Circular 68, 238 pp.
- O'Connor, B. J., 1987, Ceramic and structural clays of Gordon County, Georgia: Georgia Geologic Survey, Information Circular 69, 106 pp.
- O'Connor, B. J., 1988a, Ceramic and structural clays of Murray County, Georgia: Georgia Geologic Survey, Information Circular 70, 81 pp.
- O'Connor, B. J., 1988b, Ceramic and structural clays of Polk County, Georgia: Georgia Geologic Survey, Information Circular 71, 130 pp.
- O'Connor, B. J., 1988c, Ceramic and structural clays of Walker County, Georgia: Georgia Geologic Survey, Information Circular 72, 158 pp.
- O'Connor, B. J., 1988d, Ceramic and structural clays of Whitfield County, Georgia: Georgia Geologic Survey, Information Circular 73, 86 pp.
- O'Connor, B. J., 1989, An overview of the geology of clays, shales and slates utilized in ceramic and structural clay products in Georgia; *in* Hughes, R. E., and Bradbury, J. C. (eds.), Proceedings of the 23th Forum on the Geology of Industrial Minerals: Illinois Geological Survey, INM 102, pp. 91-95.
- O'Connor, B. J., 1990, The industrial rocks and minerals in Georgia-An overview; *in* Zupan, A. J., and Maybin, A. H., III (eds.), Proceedings of the 24th annual Forum on the Geology of Industrial Minerals, South Carolina Geological Survey, pp. 95-110.
- Popenoe, P., 1992, Maps and cross sections depicting the shallow seismic stratigraphy of the Continental Shelf and slope off Georgia from interpretation of high-resolution seismic-reflection data: Georgia Geologic Survey, Project Report 15, 35 pp.
- Shapiro, E. A., 1986, Status report-Accelerated Economics Minerals Program: July 1985 through September 1986: Georgia Geologic Survey, Open-file Report 87-1, 55 pp.
- Shapiro, E. A., 1987, Status report-Accelerated Economics Minerals Program: July 1986 through June 1987: Georgia Geologic Survey, Open-file Report 88-1, 68 pp.
- Shapiro, E. A., 1988, Status report-Accelerated Economics Minerals Program: July 1987 through June 1988: Georgia Geologic Survey, Open-file Report 89-1, 79 pp.
- Shapiro, E. A., 1990, Status report-Accelerated Economics Minerals Program: July 1988 through June 1989: Georgia Geologic Survey, Open-file Report 90-2, 85 pp.
- Shapiro, E. A., and Bonn, G. N., 1990, Heavy-mineral-bearing sands of coastal Georgia; *in* Hunt, M. C., Doenges, S., and Stubbs, G. S. (eds.), Proceedings of the second symposium on studies related to continental margins-A summary of year-three and year-four activities: Minerals Management Service, Austin, Texas, pp. 105-111.
- Sikich, S. W., and O'Connor, B. J., 1994, The mineral industry of Georgia: U.S. Bureau of Mines, Annual Report 1992, 14 pp.
- Steele, W. M., 1986, Petroleum exploration wells in Georgia 1979-1984: Georgia Geologic Survey, Information Circular 77, 24 pp.
- Taylor, L., Harding, J., Henry, V. J., Kelly, J., and Trulli, H., 1995, Assessment of environmental research and nonmineral resources offshore Georgia: Georgia Geologic Survey, Project Report 21, 368 pp.
- Vincent, H. R., 1983, Geoscience testing facilities in Georgia, 1982: Georgia Geologic Survey, Circular 7, 59 pp.
- Vincent, H. R., 1984, Geologic map of the Siloam Granite and vicinity, Georgia: Georgia Geologic Survey, Geologic Atlas 1, 1 plate, scale 1:48,000.
- Vincent, H. R., McConnell, K. I., and Perley, P. C., 1990, Geology of selected mafic and ultramafic rocks of Georgia-A review: Georgia Geologic Survey, Information Circular 82, 59 pp.
- Zellars-Williams, 1988, Offshore minerals assessment study: Georgia Geologic Survey, Project Report 14, 291 pp.





# Background stream-sediment geochemistry and hydrogeochemistry of a major river basin in Georgia—Use in industrial-mineral-resource and environmental studies

Mark D. Cocker

*Georgia Geologic Survey, 19 Martin Luther King, Jr., Dr., S.W., Atlanta, Georgia 30334, USA*

**Abstract**—A program to define the background geochemistry and hydrogeochemistry of major river basins in Georgia utilizes a Geographical Information System (GIS) to analyze National Uranium Resource Evaluation (NURE) geochemical and hydrogeochemical databases. The first basin examined was the Oconee River Basin in east-central Georgia. NURE data were contoured with the GIS and the resulting maps were used to evaluate relationships of the NURE data with individual geologic units and specific rock types identified and mapped with the GIS. Rock composition, geologic history, weathering, and permeability significantly influence stream-sediment geochemistry and hydrogeochemistry. Distinct regional and local geologic controls are evident in pH, conductivity, alkalinity of stream water, and in the concentration of Al, Ce, Co, Cr, Cu, Dy, Eu, Fe, Hf, K, La, Li, Lu, Mg, Mn, Na, Nb, Ni, P, Sc, Sm, Sn, Sr, Th, Ti, U, V, W, Yb, and Zn in stream sediments. Primary regional controls are tectonostratigraphic terranes in the Piedmont and stratigraphy of the Coastal Plain. Primary local controls include individually mapped rock units such as granites and gabbros. The NURE stream-sediment geochemical data define areas that may contain the following types of mineral resources: (1) heavy-mineral placers or paleoplacers; (2) pegmatites, granites, or metamorphic rock units rich in K- or Na-feldspar; (3) kaolin deposits; and (4) base-metal sulfides.

The NURE databases, collected during the 1976-1978 period, provide important baseline geochemical and hydrogeochemical information with which to evaluate more recent data for environmental studies. The baseline data are important for maintenance of water quality and river-basin management planning and may be useful for permitting such activities as mineral exploration, mining, mining reclamation, landfill siting, sewage treatment, other activities that may discharge into streams or rivers, and for radon-potential studies. Local increases in the concentration of certain heavy metals and changes in pH, conductivity, and alkalinity of streams that differ from background data suggest that some of the NURE data may indicate prior anthropogenic contamination.

## Geoquímica e hidrogeoquímica de sedimentos fluviales en una cuenca fluvial mayor de Georgia—Su use como información de base en estudios de minerales industriales y del ambiente natural

**Resumen**—En un programa para adquirir información geoquímica e hidrogeoquímica de base en cuencas fluviales mayores del estado de Georgia se utiliza un Sistema de Información Geográfica (*Geographical Information System [GIS]*) para analizar compilaciones de datos geoquímicos e hidrogeoquímicos adquiridos por la Evaluación Nacional de Recursos de Uranio (*National Uranium Resource Evaluation [NURE]*). La primera cuenca que se examinó fue la de Río Oconee, en el centro-este de Georgia. Los datos de NURE fueron contorneados con GIS y los mapas producidos luego fueron usados para relacionar los datos con unidades geológicas individuales y con litologías específicas que habían sido identificadas y levantadas con GIS. La composición de las rocas, la historia geológica, la alteración y la permeabilidad tienen efectos apreciables sobre la geoquímica e hidrogeoquímica de sedimentos fluviales derivados. Expresos controles geológicos regionales y locales se manifiestan en pH, conductividad y alcalinidad de las aguas fluviales y en la concentración de Al, Ce, Co, Cr, Cu, Dy, Eu, Fe, Hf, K, La, Li, Lu, Mg, Mn, Na, Nb, Ni, P, Sc, Sm, Sn, Sr, Th, Ti, U, V, W, Yb y Zn en los sedimentos fluviales. Los controles primarios regionales son terrenos tectonoestratigráficos en el Pie de Monte y la estratigrafía de la Planicie Costanera. Los controles primarios locales son unidades litológicas individuales, tales como granitos y gabbros. Los datos geoquímicos NURE de sedimentos fluviales definen áreas que pueden contener los tipos siguientes de recursos minerales: (1) pláceres de minerales pesados o paleopláceres, (2) pegmatitas, granitos o unidades de rocas metamórficas ricas en feldspatos de potasio o sodio, (3) depósitos de caolín y (4) sulfuros de metales comunes.

Las colecciones de datos NURE, reunidos entre 1976 y 1978, suministran importante información geoquímica e hidrogeoquímica que forma la base de comparación con datos más recientes recogidos en el curso de estudios ambientales. Estos datos de base son importantes para mantener la calidad de aguas potables y para la administración de la cuenca fluvial. Podrían ser útiles también para otorgar permisos de actividades tales como exploración mineral, minería, reclamación de terrenos minados, la ubicación de rellenos de tierra (*landfills*), el tratamiento de aguas servidas u otras actividades que producen descargas en ríos o arroyos, así como estudios para determinar el potencial de ciertas áreas para emanaciones de radón. Incrementos locales en la concentración de ciertos metales pesados y cambios del pH, conductividad y alcalinidad de ríos y arroyos y que difieren de las concentraciones base sugieren que los datos de NURE pueden indicar contaminación antropogénica anterior.

## Introduction

Mapping of surficial geochemical data for states, provinces, and countries during the past decade provides an overview of relative geochemical abundance levels, regional trends, and anomalous patterns (Koch et al., 1979; Koch, 1988; Darnley, 1990; Bolviken et al., 1990; McMillan et al., 1990; Kerr and Davenport, 1990; Reid, 1993; Birke and Rauch, 1993; Davenport et al., 1993; Simpson et al., 1993; and Xie and Ren, 1993). Surficial geochemical data can be significant in mineral-resource, geological, agricultural, and forestry evaluations and waste-disposal siting. The data can also be useful in health and environmental studies, particularly in areas such as the southeastern United States where rock exposures are poor.

In Georgia, surficial geochemical data as well as stream hydrogeochemical data and bedrock geology are being documented for each major river basin to aid in planning for the maintenance of surface-water quality (Cocker, 1995b; Cocker, in review). The geochemical data are used to quantify natural geochemical baselines and anthropogenic effects. These data may also be used for mineral-resource evaluation and locating potentially economic mineral resources. Environmental effects of mineral-resource exploration, development, and remediation on surface-water quality may be evaluated relative to these data.

The Oconee River Basin (ORB) in east-central Georgia (Fig. 1) is the first major river basin in the state to be systematically documented with respect to available geochemical and geological data. Important kaolin, granite, and pegmatitic feldspar and mica deposits are found in the ORB. Pegmatitic rare-, base-, and precious-metal and heavy-mineral deposits also may be present (Cocker, 1995a, c).

Cocker (1995b, in review) used the U.S. Department of Energy's NURE stream-sediment geochemical and hydrogeochemical databases collected during the late

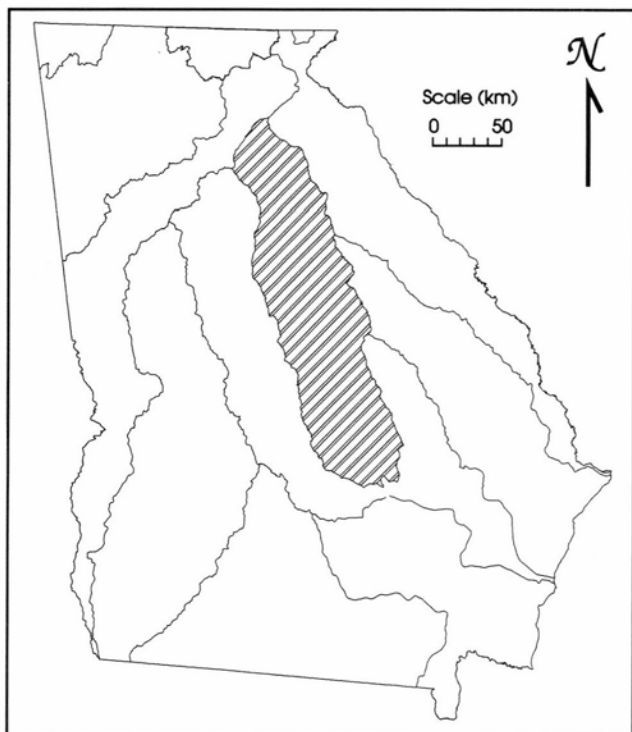

FIGURE 1—Location of the Oconee River Basin (shaded) in Georgia. Other major river basins are outlined.

1970s as the primary databases for analysis. The spatial relationship of the geochemical data to different rock units shown on a digitized version of the Geologic Map of Georgia (Georgia Geologic Survey, 1976) was used to interpret the data. A computer-based GIS was used because of the variety of databases, the different geographic extents and scales, and types of data.

This paper briefly describes the ORB and its geology and discusses geochemical associations derived from analysis of the NURE data. Several representative GIS-contoured geochemical maps and GIS-selected data are discussed as examples to use in mineral-resource evaluation and environmental studies of the ORB.

## Description of the Oconee River Basin (ORB)

The ORB covers 13,820 km<sup>2</sup>, averages about 60 km in width, and is 270 km long. It includes parts or all of 27 counties. Several mid-sized cities including Athens, Milledgeville, and Dublin, and two regional reservoirs, are in the ORB.

The ORB crosses the Piedmont and part of the Coastal Plain Physiographic provinces. Major rivers and streams in the ORB generally flow southeast across the Piedmont and the Coastal Plain. About 60% of the basin is in the Piedmont and the remaining 40% in the Coastal Plain. Piedmont province topography is characterized by broad, generally flat surfaces cut by steep-sided valleys containing major streams. The boundary between the Piedmont and Coastal Plain is a conspicuous topographic break referred to as the Fall Line (Fig. 2). Coastal Plain topography is characterized by deeply dissected, hilly terrain near the Fall Line and more gentle terrain toward the southern end of the ORB.

## General geology of the Oconee River Basin

The lithologic composition of the ORB and the distribution of specific rock units as derived by GIS analysis of the Geologic Map of Georgia (Georgia Geological Survey, 1976) indicate that various types of gneiss, including biotite gneiss, granite gneiss, and amphibolite gneiss, are the dominant (57%) lithologies in the ORB. In the Coastal Plain, which occupies 39% of the ORB, sands and clays make up 85% of the sediments, and the remaining 15% are calcareous sediments or Quaternary alluvium.

In the ORB the Piedmont is divided into two major Paleozoic-age tectonostratigraphic terranes—the Inner Piedmont to the north and the Carolina terrane to the south (Fig. 2). Cataclastic rocks of the Towaliga fault zone separate the Carolina and Inner Piedmont terranes (Williams, 1978). Cataclastic rocks of the Brevard fault zone mark the northern boundary of the Inner Piedmont with the Blue Ridge terrane (Fig. 2). Regional tectonic fabric trends are approximately N45°E. Younger faults, igneous dikes, and granitic intrusions cut across the main regional fabric from northwest to southeast. The Inner Piedmont and Carolina terranes differ in overall rock composition and metamorphic grade. This is reflected in the stream-sediment geochemistry and hydrogeochemistry on both sides of the Towaliga fault zone.

The Inner Piedmont contains mainly migmatitic granitic and biotitic (intermediate) gneisses with lesser amounts of schists, amphibolites, and ultramafic rocks. Protoliths for these Inner Piedmont rocks were primarily sedimentary and perhaps felsic-to-intermediate igneous

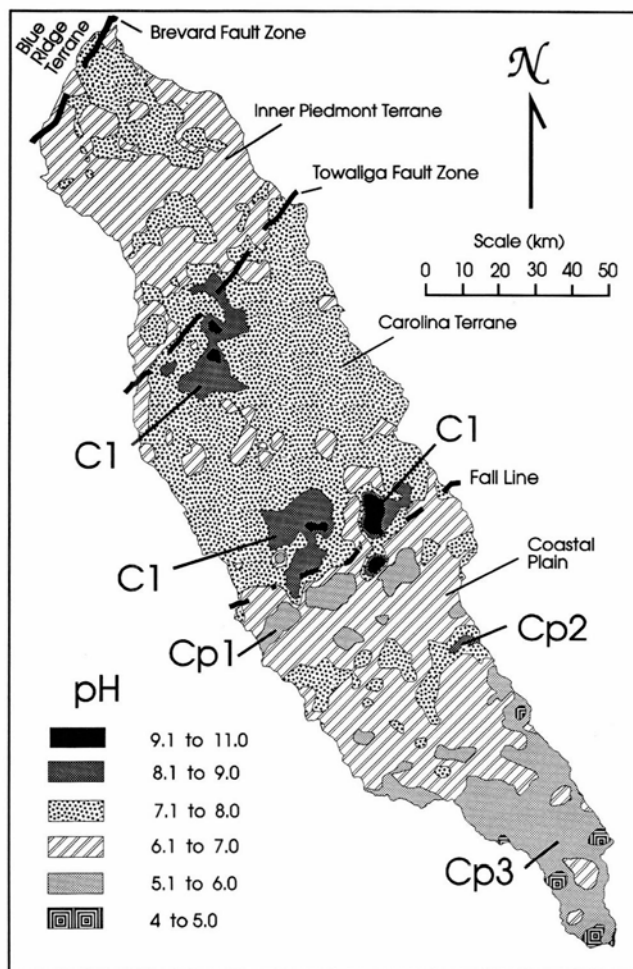

FIGURE 2—Distribution of stream pH in the Oconee River Basin. Locations of the major tectonic terranes (Blue Ridge, Inner Piedmont, and Carolina) and the Coastal Plain are shown. Traces of the major faults that separate these terranes are indicated on the map. The Fall Line marks the northern edge of the Coastal Plain. Specific features (C1, Cp1, etc.) are discussed in the text.

rocks (Horton and McConnell, 1991). Metamorphic grade is moderate to high. Granitic gneisses include metamorphosed granodiorites, granodioritic gneisses, two-mica gneisses and migmatites, as well as minor amphibolitic gneisses. Many of the biotitic (or intermediate) gneisses are migmatites and paragneisses. Schistose rock units include staurolite-mica schist, sillimanite-mica schist, sillimanite-graphite schist, biotite schist, and muscovite-biotite-tourmaline schist. Quartzites include amphibole-plagioclase quartzite, garnet-plagioclase quartzite, feldspar quartzite, sillimanite-garnet quartzite, and massive quartzite.

The Carolina terrane is composed of lower-metamorphic-grade mafic to felsic metavolcanic and meta-volcaniclastic rocks of the Carolina slate belt and intermediate-grade metamorphic rocks of the Charlotte belt. This terrane may be a remnant of a Late Proterozoic to Middle Cambrian island-arc complex thrust onto North America (Williams and Hatcher, 1983). Biotitic gneisses and aluminous schists are also found in the Carolina terrane. Mafic and ultramafic rocks include amphibolites, amphibolitic gneisses, serpentinites, and gabbroic intrusions. Mafic and ultramafic rock units found along northeast-trending linear belts may be igneous intru-

sions or remnants of oceanic crust tectonically emplaced along crustal sutures. Portions of several late Paleozoic granite plutons (i.e. Elberton, Siloam, and Sparta Granites) are found in the eastern half of the basin. Pyroxenite, gabbro, and tonalite intrusions extend to the northeast along the southern and northern edges of the Carolina terrane (Libby, 1971; Conway, 1986; Dunnagan, 1986; Davidson, 1981; Allard and Whitney, 1994).

The Coastal Plain portion of the ORB consists of Cretaceous to Eocene sandy and clayey units near the Fall Line, Eocene to Oligocene calcareous sediments near the middle, and Miocene sandy sediments in the southern third. Hetrick and Friddell (1990) described and mapped the stratigraphy of the Coastal Plain near the Fall Line in greater detail.

### Mineral resources

A variety of mineral resources are found within or adjacent to the ORB. Crushed stone, gravel, kaolin, dimension stone, feldspar, and mica are the principal non-metallic products. Deposits of olivine, asbestos, corundum, vermiculite, talc, kyanite, sillimanite, and various heavy minerals are also found in the ORB, but have not been of economic importance. Base and precious metals have been prospected or mined principally in areas east of and adjacent to the ORB. The mineral resources are commonly concentrated in elongate bands or "belts" that in general trend across the ORB from southwest to northeast. These belts are generally associated with specific groups of rock units. The principal mineral belts include the Piedmont monazite belt (Mertie, 1979), several strings of mafic and ultramafic intrusive igneous rocks, several pegmatite districts, the Carolina slate belt, and the Coastal Plain kaolin belt.

The Piedmont monazite belt contains phosphates, oxides, and silicates of Th, U, Ce, Dy, Eu, Hf, La, Lu, Sm, Ti, Yb, and Zr (Overstreet et al., 1968; Mertie, 1979). These minerals occur principally within granitic and intermediate/biotitic gneisses and migmatitic rocks north of the Towaliga fault zone in the Inner Piedmont (Woolsey, 1973). The monazite belt may represent metamorphosed paleoplacer meposits. Repeated cycles of weathering, erosion, deposition, and sedimentary fractionation have also formed heavy-mineral concentrations in Cretaceous and Eocene sandy sediments south of the Fall Line. Similar concentrations are found along ancient and present shorelines along the Georgia coast and on the Continental Shelf.

The mafic and ultramafic rocks commonly contain disseminated metallic sulfides and oxides and may host massive metallic sulfide and oxide deposits that contain Cu, Pb, Zn, Ni, Fe, Ti, V, Mn, Cr, Co, and rare-earth elements (Cocker, 1992). The Gladesville Norite on the western edge of the ORB contains Cu and Ni mineralization (Carpenter and Hughes, 1970; Cocker, 1995a) and is locally enriched in Co, Pt, Pd, and Au (Cocker, 1995a). This intrusion is also an important host for large feldspar-rich pegmatites of the Jasper County pegmatite district (Cocker, 1995c).

The Jasper County pegmatite district is the principal pegmatite district in the ORB and has good potential for additional pegmatitic-feldspar deposits (Cocker, 1995c). This district was the largest source of pegmatitic feldspar in Georgia and was one of the largest in the United States. The pegmatite bodies may be over 33 m wide and most are 65 to over 325 m long. Pegmatite mineralogy is microcline, perthite, and milky quartz with locally abundant muscovite, sodic feldspar, biotite, vermiculite (al-

tered from biotite), garnet, and pyrite. Major- and trace-element geochemistry of the pegmatites indicates that rare metals may be enriched in the northeastern part 01 the district (Cocker, 1995c).

Volcanogenic deposits within the Carolina slate belt contain Au, Cu, Pb, Zn, Fe, Mn, and Ba mineralization (Feiss and Slack, 1989; Allard and Whitney, 1994). Industrial minerals are commonly developed in or near the volcanogenic mineralization. Aluminosilicate deposits such as kyanite, pyrophyllite, or sillimanite (at Graves Mountain, Georgia; Willis Mountain, Virginia; and Hillsborough and Robbins—Glendon, North Carolina), are interpreted as metamorphosed alteration zones associated with volcanogenic mineralization (Feiss and Slack, 1989). The barite deposit at Barite Hill and the "mineralite" deposit at the Haile Mine, South Carolina, also are associated with volcanogenic sulfide mineralization.

The Elberton, Siloam, and Sparta granitic intrusions are important sources of crushed stone, dimension stone, and feldspar in the ORB. The extremely homogeneous, fine-grained, equigranular granite of the Elberton Granite is the principal dimension stone in Georgia. Microcline phenocrysts recovered from deeply weathered portions of the Siloam Granite, a multiphase-porphyratic-biotite granite (Vincent, 1984; Humphrey and Radcliffe, 1972), have replaced the pegmatites of the Jasper County district as the main source of K-feldspar. Small, unnamed, and undocumented granitic intrusions are the principal sources of sodic feldspar that are blended with K-feldspar for ceramics. Several quarries for dimension stone and crushed aggregate are developed in the Sparta Granite, a multiphase quartz-monzonite or granite/ adamellite intrusion in the southeast corner of the Carolina terrane (Humphrey and Radcliffe, 1972; Roberts-Henry, 1983).

The Georgia—South Carolina kaolin district extends through the ORB within Late Cretaceous to mid-Eocene sediments south of the Fall Line (Shrum, 1970; Riggs and Manheim, 1988). The kaolin is found as tabular lenses and discontinuous beds that were deposited in shallow water under fluvial/deltaic/coastal-marine environments. Heavy minerals are locally concentrated in or near these kaolin deposits (Hetrick and Friddell, 1990; Riggs and Manheim, 1988).

## Geochemistry

### Geochemical databases

This study used stream-sediment geochemical and hydrogeochemical databases collected during the late 1970s during the U.S. Department of Energy's NURE program. These databases provide the most extensive data for the ORB. The NURE databases were collected during a short period from 1976 to 1978.

The NURE Program was established to evaluate domestic uranium resources and to identify areas favorable for uranium exploration. NURE geochemical data and technical information concerning the types of data collected are on a CD-ROM disk (Hoffman and Buttleman, 1994). The U.S. Department of Energy's Savannah River Laboratory (SRL) directed the program for the 30 eastern states that included Georgia. To improve comparability, analyses were performed by the same laboratory using the same analytical procedures. SRL contracted sample collection and performed the laboratory analyses.

Data are organized by individual 1° x 2° National Topographic Map Series (NTMS) quadrangles. The ORB includes parts of the Greenville, Athens, Macon, and

Waycross NTMS quadrangles. Rock, soil, and saprolite samples also were collected for the Athens 1° x 2° quadrangle that crosses the middle of the ORB.

### Sample collection and analysis

A total of 792 NURE stream-sediment sample sites are within the ORB. Each stream-sediment sample represents an average area of 17 km<sup>2</sup>. More than 98% of the digitized sample locations were judged to be located as accurately as could be plotted on county road maps (Ferguson, 1978).

A minimum of five sediment sub-samples were composited from each stream site. Approximately 400 g of sediment passing a 420µm (U.S. Std. 40-mesh) screen were collected. A sample of one liter of filtered water was collected at each ground-water site (Ferguson, 1978).

Initial analyses included a suite of elements for nearly all the stream-sediment samples. All analyses were done by automated neutron-activation techniques (NAA) at the Savannah River Laboratory (Ferguson, 1978). Conductivity, pH, alkalinity, and temperature were measured from water samples collected at each site. Later, more than half of the ORB samples were analyzed for a second suite of elements. The stream sediments were analyzed for Ag, Al, Be, Ce, Co, Cr, Cu, Dy, Eu, Fe, Hf, K, La, Li, Lu, Mo, Mn, Mo, Na, Nb, Ni, P, Pb, Sc, Sm, Sn, Sr, Th, Ti, U, V, W, Yb, and Zn.

### Analysis of the geochemical data

Cocker (1995b, in review) used a GIS to contour the geochemical data and to identify and extract from other databases specific items such as drainage-basin boundaries, rock units, different types of samples, and unique geochemical values or ranges of geochemical values. The GIS selected single- or multi-element data for a river basin and areas adjacent to that basin and displayed that data with geographical or geologic information. In addition, the GIS identified sample points within each particular rock unit and calculated means, standard deviations, and correlation coefficients for each rock unit. Correlation coefficients helped to determine the more prominent geochemical relations (Table 1). The mineralogy and rock types or suites suggested by those geochemical relations and basin geology are summarized in Table 2.

The strongest correlations are those in the Ce—Dy—Th—La—Yb—Sm—Eu—Lu—Hf and Sc—Fe—V—Mg—Na—Mn—Al—Ti—Sr—alkalinity—pH—conductivity groups (Table 1). The first group probably indicates the presence of monazite in the stream sediments. The sec-

TABLE 1—Geochemical associations based on correlation coefficients.

(1)	Ce—Dy—Th—La—Yb—Sm—Eu—Lu—Hf
(2)	Sc—Fe—V—Mg—Na—Mn—Al—Ti—Sr—alkalinity—pH—conductivity
(3)	Hf—U—Th
(4)	Zn—Co—Cu—Ni
(5)	Li—Be—Mo—Zn—K—W
(6)	Sn—Be—K

TABLE 2—Mineralogy and rock types suggested by correlation associations and geology.

(1)	Monazite
(2)	Metavolcanic rocks of the Carolina terrane
(3)	Zircon
(4)	Base-metal sulfides
(5)	Pegmatites and granites
(6)	Pegmatites and granitic greisens

and group is spatially associated with the metavolcanic rocks of the Carolina terrane and probably indicates the presence of (1) Mn- and V-bearing Fe-Ti oxides, such as magnetite and ilmenite, and (2) mafic silicates such as amphiboles, pyroxenes, and olivine. The presence of sodic plagioclase, and perhaps sodic amphibole, is suggested by Na and Al. The association of Sr may indicate the presence of disseminated carbonates in the metavolcanic rocks of the Carolina terrane. Weathering of carbonates, Fe-Mg silicates, and plagioclase will have a strong effect on stream alkalinity, pH, and conductivity.

The third group in Table 1 (Hf-U-Th) may indicate the presence of zircon in the stream sediments. As an example, the distribution of Th is contoured in Figure 3.

The association of Zn-Co-Cu-Ni may indicate the presence of base-metal sulfides. Base-metal mineralization in the Carolina terrane is commonly associated with Au mineralization (Allard and Whitney, 1994). Little correlation exists between Pb and the other base-metal sulfides; high Pb concentrations may be due to another factor such as anthropogenic contamination.

The last two associations are not as strong as the first four groups but may indicate the presence of two separate felsic-rock suites. A granitic-pegmatite suite is suggested by the Li-Be-Mo-Zn-K-W group. The Sn-Be-K association may indicate a granitic-greisen suite or perhaps a different suite of pegmatites.

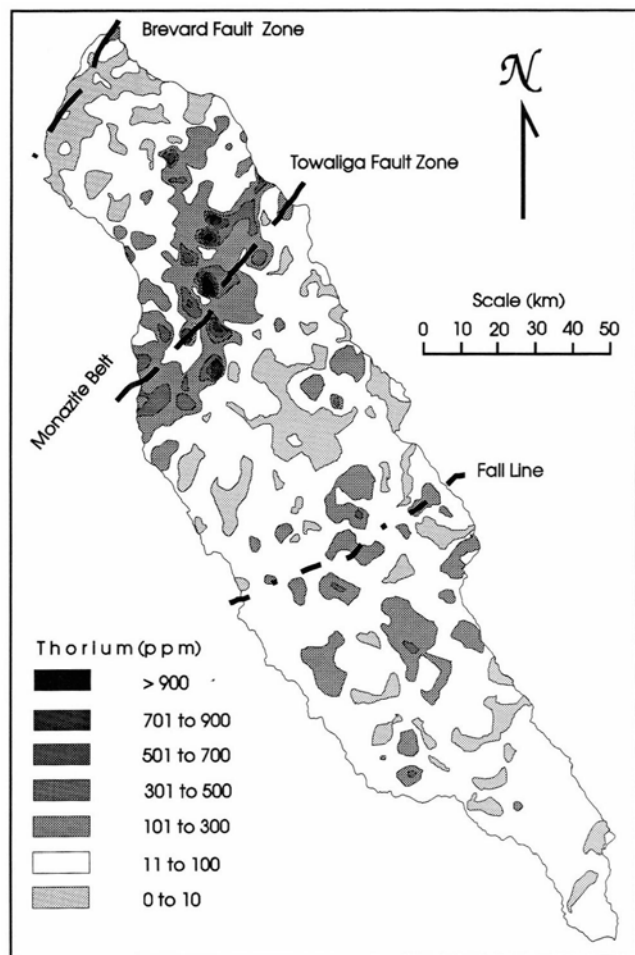

FIGURE 3—Distribution of thorium (Th) in the Oconee River Basin. Borders between the tectonic terranes and the Coastal Plain are as shown in Figure 2. The monazite belt extends north-eastward, generally along the northwestern side of the Towaliga fault zone.

### Regional geologic controls on geochemistry

Regional geologic controls on river-basin geochemistry and hydrogeochemistry may be demonstrated by stream hydrogeochemistry and the distribution of monazite and zircon. These are illustrated by distribution maps of pH (Fig. 2) and Th (Fig. 3).

**Stream hydrogeochemistry**—As shown in Figure 2, the ORB cuts across five regions which differ in pH, conductivity, and alkalinity. Two regions are characterized by streams with higher pH ( $>7$ ), conductivity ( $>50$  microohms/cm), and alkalinity ( $>0.3$  meq/L), and three regions are characterized by streams with lower pH ( $<7$ ), conductivity ( $<50$  microohms/cm), and alkalinity ( $<0.3$  meq/L) (Cocker, 1995b, in review).

In the northern half of the ORB, the region of higher alkalinity, conductivity, and pH is coincident with low-to-intermediate metamorphic grade, metavolcanic, and metavolcaniclastic rocks of the Carolina terrane (Fig. 2). Smaller areas (C1, Fig. 2) of higher alkalinity, conductivity, and pH (8.1-11.0) generally correlate with mafic rocks such as norites, gabbros, diorites, amphibolites, and amphibolitic gneisses (Cocker, in review). Streams within the Carolina terrane may be buffered by solution and hydrolysis of secondary carbonates and/or by hydrolysis of Fe-Mg silicates in the metavolcanics and metavolcaniclastic rocks of the Carolina terrane. Areas with the most alkaline streams (pH  $>8$ ) are underlain by hornblende gneiss and gabbroic intrusions, and their pH is probably related to a greater abundance of weathering mafic silicates and carbonates. Conductivity, which is related to the amount of dissolved solids, tends to be greater in streams where weathering and solution of mafic silicates and carbonates have occurred. Because rocks of the Carolina terrane are of lower metamorphic grade and are compositionally (amphiboles, pyroxenes, sodic plagioclase, and carbonates) more susceptible to weathering than rocks within the Inner Piedmont, they contribute more dissolved material to the streams, thereby elevating stream conductivity. In streams with lower pH (pH  $<7.1$ , Fig. 2), conductivity and alkalinity are coincident with high metamorphic grade, metasedimentary, granitic, and intermediate gneissic rocks of the Inner Piedmont terrane.

In the Coastal Plain, regions of higher alkalinity, conductivity, and pH (Cp2, Fig. 2) are spatially coincident with Eocene and Oligocene calcareous strata. Regions of higher pH in Figure 2 form a V-shape down dip, as do the strata on the Geologic Map of Georgia (Georgia Geologic Survey, 1976). In regions of low pH (Cp1 and Cp3, Fig. 2), conductivity and alkalinity are underlain by sandy sediments and clays of Cretaceous, Eocene (Cp1), and Miocene (Cp3) age. The northwest edge of the Cp3 region also forms a rough V-shape following compositional changes in the Coastal Plain strata. Increased acidity of streams within the Coastal Plain may be attributed to slow-flowing streams high in organic matter, and to highly permeable and relatively non-reactive sandy sediments (Cocker, 1995b, in review).

Because of relatively slow reaction rates under surface conditions, the reaction of water with impermeable or highly permeable rocks and sediments is expected to be minimal. The pH, conductivity, and alkalinity of surface water in contact with these types of rocks will more closely resemble rain water that has low pH, conductivity, and alkalinity. Also, water in contact with quartzose and granitic rocks is lower in dissolved solids because of the lower susceptibility of the felsic minerals to weathering.

Stream pH has an important effect on the dissolution or precipitation of metals. Stream-sediment geochemistry affects stream hydrogeochemistry and also has important buffering effects. Naturally buffered stream water in areas of sulfide mineralization can significantly reduce effects of land disturbance associated with mining or exploration activities.

### Stream-sediment geochemistry

**Heavy minerals (monazite and zircon)**—The two associations noted earlier, which indicate the likely presence of monazite and zircon, generally form similar distribution patterns in the ORB. The primary, strongest trend in the distribution of Ce, Dy, Th, La, Yb, Sm, Eu, Lu, Hf, and U defines what is called the monazite belt. This belt, as defined by Mertie (1979), extends in a northeast direction through most of the southeast Piedmont and cuts obliquely across the ORB within the Inner Piedmont and north of the Towaliga fault zone. Distribution of Th (Fig. 3) is a similar but simpler version of some of the more complex patterns displayed by elements such as Ce, La, and Sm. Higher concentrations of Th, as depicted by areas containing more than 100 ppm Th, extend south of the trace of the Towaliga fault zone. The location of this fault is uncertain in this part of Georgia, as depicted on the Geologic Map of Georgia (Georgia Geologic Survey, 1976).

Exploration for heavy-mineral deposits in the ORB may be enhanced through use of geochemical maps such as that for Th (Fig. 3). The geochemical maps of the NURE data more closely define and also expand the Monazite belt in this part of Georgia. In addition, expansion of this belt may indicate that either the Towaliga fault zone is not accurately mapped in this part of Georgia, or the heavy-mineral deposits are not necessarily restricted to metasedimentary rocks of the Inner Piedmont.

Maps such as the one for Th may also be useful in environmental studies. Maps that show the distribution of Th and U can be used to predict radon-susceptibility and areas of higher natural radioactivity with reasonably good accuracy.

### Additional uses in mineral exploration

The Al content of stream sediments may be useful for locating potential kaolin deposits and, when used in conjunction with other elements such as Na and K, potential sources of pegmatitic or granitic rocks. Stream sediments of the Coastal Plain generally contain less than 20,000 ppm Al and are distinctly different from those in the Piedmont that typically have more than 30,000 ppm Al (Cocker, in review). Cretaceous-early Tertiary undifferentiated sediments contain the highest Al (31,694 ppm) and the highest single analysis (169,000 ppm) in the Coastal Plain and may be related to the kaolin deposits. Within the Piedmont, high-mean Al concentrations (>70,000 ppm) are generally found within the Carolina terrane and may be related to the abundance of sodic plagioclase in the metavolcanic rocks. Locally within the Carolina terrane, large, feldspar-rich pegmatites in the Jasper County pegmatite district and sodic granites to the northeast of that district may be local sources for Al-rich sediments. The Elberton and Siloam Granites are also local sources of Al (50,000 - 80,000 ppm).

Sediments derived from pegmatites may be distinguished from other Al-rich sediments through the Li-Be-Mo-Zn-K-W and Sn-Be-K associations. Sedi-

ments containing elevated concentrations of Be (generally >3 ppm Be in the ORB) may be considered anomalous (Cocker, in review).

The Zn-Co-Cu-Ni association, particularly within the Carolina terrane, suggests the presence of base-metal sulfides. Stream sediments in the ORB with Cu >10 ppm, Co >10 ppm, Ni >6 ppm, and Zn >30 ppm are distinctly higher than background values (Cocker, in review). The presence of kyanite, barite, and "mineralite" deposits in metamorphosed alteration zones associated with volcanogenic base-metal sulfides would favor use of these metals in exploration for these industrial minerals. Concentrations of Pb >10 ppm, and as high as 525 ppm, are likely to be related to anthropogenic contamination.

As noted earlier, the Fe-Ti-V-Mn-Mg-Na-Al-Sc alkalinity-conductivity association is characteristic of the metavolcanic rocks of the Carolina terrane. Higher concentrations of Fe and Mg are commonly associated with amphibolite or hornblende gneiss, gabbros, or ultramafic rocks. In addition to the use of these metals in defining rock units and tectonic terranes, the ferrous metals may influence water quality and be extremely useful in mineral-resource studies. The direct effect of Fe and Mn on water quality is their tendency to form oxide or hydroxide crusts that may precipitate or adsorb heavy metals. Iron in sediments is an indication of the abundance of Fe-bearing minerals. Stream pH tends to rise because of hydrolysis of Fe-bearing silicates.

### Use in environmental studies

Geochemical, hydrogeochemical, and geological data documented and interpreted for the ORB will be critical for water-quality studies and river-basin-management planning (Cocker, 1995b; Cocker, in review). The NURE geochemical data provide a unique baseline of information from the late 1970s with which to examine subsequent changes in water quality. Chemical analysis by the same lab and by the same procedures permits comparisons of the NURE geochemical data within this basin and to other basins in the state. Regional reservoirs in the Piedmont are the primary source of drinking water for cities in the Piedmont. Planning and siting of these reservoirs may be guided by examination of the NURE data.

Recharge zones for regionally important Coastal Plain aquifers are located in the Cretaceous to Eocene strata that extend through the ORB. Guidelines for protection of these recharge zones may be established through use of the NURE geochemical data.

NURE geochemical data may also be of importance in landfill-siting issues. Background data and pre-existing geochemical anomalies can be used for landfill-siting and for monitoring leakage. Anthropogenic contamination can be identified and targeted for further study.

**Identification of contamination—Contamination of stream sediments** may come from a variety of sources. The NURE databases document human activities near the sample sites that might influence the analytical results. These include mining, sewage, sanitary landfills (dumps), farming, urban, and other activities. In general, urban, sanitary landfill, and sewage activities appear to impact stream-sediment geochemistry and stream hydrogeochemistry to a greater degree than the other activities in the ORB. At those sample sites that may be affected by contamination, maximum concentrations in stream sediments are 31 ppm Co, 38 ppm Cu, 30 ppm Ni, 525 ppm



Pb, 125 ppm Zn, 125,000 ppm Fe, 40 ppm Sn, 204,000 ppm Ti, 240 ppm V. A maximum conductivity of 173 microohms/cm was also noted at one of those sample sites.

Samples collected near mining activities contained higher Al (53,580 ppm) and lower Fe (16,960 ppm) than "non-contaminated" samples. Most of these sites are near kaolin mines in the Coastal Plain counties of Twiggs, Wilkinson, and Washington. A particularly high conductivity of 750 microohms/cm may be related to nearby kaolin processing in Sandersville.

### Summary

Databases created by the U.S. Department of Energy's NURE stream-sediment reconnaissance program provide important baseline geochemical data from the late 1970s. These geochemical data were used with a computer-based Geographical Information System and a geology coverage created from the Geologic Map of Georgia (Georgia Geological Survey, 1976) to define the background geochemistry and hydrogeochemistry of the Oconee River Basin as well as factors that control the geochemistry and hydrogeochemistry.

Major regional factors controlling distribution of metals within the ORB are the differences in composition and geologic history of igneous and metamorphic rocks between two regional tectonostratigraphic terranes of the Piedmont and between the crystalline rocks and the sediments of the Georgia Coastal Plain. Stream sediments within the Carolina terrane generally have higher concentrations of Fe, Mn, Ti, V, Mg, and Na than stream sediments of the Inner Piedmont or Coastal Plain. Mafic metavolcanic and metaplutonic rocks and associated stream sediments within the Carolina terrane are more reactive as suggested by higher pH, conductivity, and alkalinity in the streams. Calcareous sediments within the Coastal Plain may buffer rain and surface water by raising the pH and alkalinity and contribute more dissolved solids as measured by the higher conductivities. Sandy, permeable sediments and high amounts of decaying carbonaceous matter in slow-flowing streams of the Coastal Plain contribute to lower pH, conductivity, and alkalinity.

Mineral resources such as kaolin, aluminosilicates, barite, heavy minerals, base and precious metals, granitic rocks, and pegmatites found in or adjacent to the ORB may be located and evaluated through use of the NURE geochemical data and the GIS analysis of those data. Environmental studies related to mineral-resource exploration, development, and remediation may be also aided by the data and data analysis. Other environmental concerns, such as those related to water-quality and river-basin management, landfill siting, radon, and radioactivity studies may also benefit.

### Acknowledgments

The author wishes to thank Bruce O'Connor, Robin McDowell, and Earl Shapiro of the Georgia Geologic Survey for their reviews of an early draft of this manuscript.

### References

- Allard, G. O., and Whitney, J. A., 1994, Geology of the Inner Piedmont Carolina terrane, and Modoc zone in northeast Georgia: Georgia Geological Survey, Project Report 20, 36 pp.
- Birke, M., and Rauch, U., 1993, Environmental aspects of the regional geochemical survey in the southern part of East Germany; *in* Davenport, P. H. (ed.), *Geochemical mapping: Journal of Geochemical Exploration*, v. 49, pp. 177-200.
- Bolviken, B., Kullerud, G., and Loucks, R. R., 1990, Geochemical and metallogenic provinces—A discussion initiated by results from geochemical mapping across northern Fennoscandia; *in* Darnley, A. G., and Garrett, R. G. (eds.), *International geochemical mapping: Journal of Geochemical Exploration*, v. 39, pp. 49-90.
- Carpenter, R. H., and Hughes, T. C., 1970, A geochemical and geophysical survey of the Gladesville Norite, Jasper County, Georgia: Geological Survey of Georgia, Information Circular 37, 7 pp.
- Cocker, M. D., 1992, Mineralogy, geochemistry and genesis of REE-Ti-V-enriched iron oxides in the Burks Mountain complex, Columbia County, Georgia; *in* Rheams, K. F., and McClellan, G. H. (eds.), *Industrial minerals of the southeastern United States—Proceedings of the 2nd annual symposium on industrial minerals: Alabama Geological Survey, Circular 161*, pp. 77-89.
- Cocker, M. D., 1995a, Base- and precious-metal and major-element trends in the Gladesville layered mafic intrusion, Jasper County, Georgia (abs.): *Geological Society of America, Abstracts with programs*, v. 27, no. 2, p. 44.
- Cocker, M. D., 1995b, Geochemistry and hydrochemistry of a major river basin in the Piedmont and Coastal Plain provinces of Georgia; *in* Hatcher, K. J. (ed.), *Proceedings of the 1995 Georgia Water Resources Conference: Carl Vinson Institute of Government, University of Georgia, Athens, Georgia*, pp. 67-70.
- Cocker, M. D., 1995c, Geological setting and geochemical trends in the Jasper County pegmatite district, Georgia; *in* Walker, B. J. (ed.), *Proceedings of the 28th Annual Forum on the Geology of the Industrial Minerals: West Virginia Geological and Economic Survey, Circular 46*, pp. 85-94.
- Cocker, M. D., in review, Distribution of selected elements in stream sediments, stream hydrochemistry and geology of the Oconee River Basin, Georgia: *Georgia Geologic Survey, Bulletin*.
- Conway, K. M., 1986, The geology of the northern two-thirds of the Philomath quadrangle, Georgia: Unpublished MS thesis, University of Georgia, 136 pp.
- Darnley, A. G., 1990, International geochemical mapping: A new global project; *in* Darnley, A. G., and Garrett, R. G. (eds.), *International geochemical mapping: Journal of Geochemical Exploration*, v. 39, pp. 1-14.
- Davenport, P. H., Christopher, T. K., Vardy, S., and Nolan, L. W., 1993, Geochemical mapping in Newfoundland and Labrador—Its role in establishing geochemical baselines for the measurement of environmental change; *in* Davenport, P. H. (ed.), *Geochemical mapping: Journal of Geochemical Exploration*, v. 49, pp. 177-200.
- Davidson, J. W., 1981, The geology, petrology, geochemistry, and economic mineral resources of east-central Oglethorpe County, Georgia: Unpublished MS thesis, University of Georgia, 224 pp.
- Dunnagan, W. B., Jr., 1986, The geology of the Washington West 7.5' quadrangle, Georgia: Unpublished MS thesis, University of Georgia, 151 pp.
- Feiss, P. G., and Slack, J. F., 1989, Mineral deposits of the U.S. Appalachians; *in* Hatcher, R. D., Jr., Thomas, W. A., and Viele, G. W. (eds.), *The geology of North America, Volume F-2, The Appalachian-Ouachita orogen in the United States: Geological Society of America*, pp. 471-494.
- Ferguson, R. B., 1978, Preliminary raw data release, Greenville 1° X 2° NTMS area, Georgia, North Carolina, and South Carolina, SRL Document DPST-78-146-2: E.I. duPont de Nemours and Company, Savannah River Laboratory, Aiken, South Carolina, 149 pp.
- Georgia Geologic Survey, 1976, *Geologic Map of Georgia: Georgia Geological Survey, scale 1:500,000*.
- Hetrick, J. H., and Friddell, M. S., 1990, A geologic atlas of the Central Georgia kaolin district: *Georgia Geological Survey, Geologic Atlas 6*, 4 pl., scale 1:100,000.



- Hoffman, J. D., and Buttleman, K. P., 1994, National geochemical data base-National uranium resource evaluation data for the conterminous United States: U.S. Geological Survey, Digital Data Series DDS-18-A, 1 CD-ROM.
- Horton, J. W., Jr., and McConnell, K. I., 1991 The western Piedmont *in* Horton, J. W., Jr., and Zullo, V. A. (eds.), The geology of the Carolinas: Carolina Geological Society, Fiftieth anniversary volume, University of Tennessee Press, pp. 36-58.
- Humphrey, R. C., and Radcliffe, D., 1972, Geology, petrology and mineral resources of the crystalline rocks of Greene and Hancock counties: Georgia Geologic Survey, [Unpublished report], 56 pp.
- Kerr, A., and Davenport, P. H., 1990, Application of geochemical mapping techniques to a complex Precambrian shield area in Labrador, Canada; *in* Darnley, A. G., and Garrett, R. G. (eds.), International geochemical mapping: Journal of Geochemical Exploration, v. 39, pp. 225-248.
- Koch, G. S., Jr., 1988, A geochemical atlas of Georgia: Georgia Geologic Survey, Geologic Atlas 3, 13 pl., scale 1:1,785,000.
- Koch, G. S., Jr., Howarth, R. J., Carpenter, R. H., and Schuenemeyer, J. H., 1979, Development of data enhancement and display techniques for stream-sediment data collected in the National Uranium Resource Evaluation program of the United States Department of Energy: University of Georgia, 223 pp.
- Libby, S. C., 1971, The petrology of the igneous rocks of Putnam County, Georgia: Unpublished MS thesis, University of Georgia, 99 pp.
- McMillan, W. J., Day, S., and Matysek, P. F., 1990, Tectonic terranes, metallogeny and regional geochemical surveys-An example from northern British Columbia; *in* Darnley, A. G., and Garrett, R. G. (eds.), International geochemical mapping: Journal of Geochemical Exploration, v. 39, pp. 175-194.
- Mertie, J. B., Jr., 1979, Monazite in the granitic rocks of the southeastern Atlantic states-An example of the use of heavy minerals in geologic exploration: U.S. Geological Survey, Professional Paper 1094, 79 pp.
- Overstreet, W. C., White, A. M., Whitlow, J. W., Theobald, P. K., Jr., Caldwell, D. W., and Cuppels, N. P., 1968, Fluvial monazite in the southeastern United States: U.S. Geological Survey, Professional Paper 568, 81 pp.
- Reid, J. C., 1993, A geochemical atlas of North Carolina, USA: Journal of Geochemical Exploration, v. 47, pp. 11-27.
- Riggs, S. R., and Manheim, F. T., 1988, Mineral resources of the U.S. Atlantic continental margin; *in* Sheridan, R. E., and Grow, J. A. (eds.), The geology of North America, Volume 1-2, The Atlantic continental margin, U.S.: Geological Society of America, pp. 501-520.
- Roberts-Henry, M., 1983, A petrographic and geochemical analysis of the Sparta granitic complex, Hancock County, Georgia: Unpublished MS thesis, University of Georgia, 343 pp.
- Shrum, R. A., 1970, Distribution of kaolin and fuller's earth mines and plants in Georgia and north Florida: Georgia Geologic Survey, Map RM-3, scale 1:250,000.
- Simpson, P. R., Edmunds, W. M., Breward, N., Cook, J. M., Flight, D., Hall, G. E. M., and Lister, T. R., 1993, Geochemical mapping of stream water for environmental studies and mineral exploration in the UK; *in* Davenport, P. H. (ed.), Geochemical mapping: Journal of Geochemical Exploration, v.49, pp. 63-88.
- Vincent, H. R., 1984, Geologic map of the Siloam Granite and vicinity, eastern Georgia: Georgia Geologic Survey, Geologic Atlas 1, 1 pl., scale 1:48,000.
- Williams, H., 1978, Tectonic-lithofacies map of the Appalachian orogen-St. John's, Newfoundland, Canada: Memorial Institute of Newfoundland, scale 1:1,000,000.
- Williams, H., and Hatcher, R. D., Jr., 1983, Appalachian suspect terranes; *in* Hatcher, R. D., Jr., Williams, H., and Zietz, I. (eds.), Contributions to the tectonics and geophysics of mountain chains: Geological Society of America, Memoir 158, pp. 33-53.
- Woolsey, J. R., Jr., 1973, The geology of Clarke County, Georgia: Unpublished MS thesis, University of Georgia, 109 pp.
- Xie, X., and Ren, T., 1993, National geochemical mapping and environmental geochemistry-Progress in China; *in* Davenport, P. H. (ed.), Geochemical mapping: Journal of Geochemical Exploration, v. 49, pp. 15-34.

# Heavy minerals in fine-grained waste materials from sand and gravel plants of Indiana

Nelson R. Shaffer

*Indiana Geological Survey, 611 North Walnut Grove, Bloomington, Indiana 47405, USA*

**Abstract**—More than 170 operations extract sand and gravel resources from both Pleistocene and Holocene deposits throughout Indiana. Considerable amounts of fine-grained wastes are discarded during processing of the approximately 27 million metric (mt) tons of sand and gravel produced annually. Analyses of fine-grained waste materials sampled from numerous (50+) sites throughout the state reveal that heavy-mineral concentrations range from a trace amount to more than 10% and average about 2.5% by dry weight of these fines (as extracted by an 18 inch rotary concentrator). Little heavy material (0.3%) passes through processing to be included in the product. Large amounts of easily recoverable waste fines languish in abandoned sites. Much of the north-central United States has been glaciated; if heavy minerals are common to these glacial terrains, then a vast potential resource exists.

Analyses of the heavy-mineral fraction show that ilmenite, garnet, zircon, and other heavy minerals occur in the wastes together with about 30-45% magnetite. Trace amounts of other economically important minerals, primarily chromite, monazite, and gold, are also present. Relative proportions of minerals vary depending on geologic and processing details. Heavies tend to be concentrated in the finer fractions, especially those <0.175 mm. Previous workers have also noted abundant (1.0-9.9%) heavies in fine (<0.175 mm) fractions. Samples with generally higher total heavy-mineral concentrations contain relatively higher percentages of magnetite.

The amount and character of heavy-mineral suites vary from site to site and certain drainage basins tend to have greater amounts of various heavy minerals; pits along two major rivers have average concentrations of about 4.5%. Heavy minerals occur in concentrations exceeding 5% within fine fractions of sand deposits throughout Indiana. Similar values have been reported in adjoining states. While generally not present in economic amounts in raw materials, select deposits could produce byproduct heavy minerals from fine-grained materials currently rejected as wastes. Once cleaned of heavy minerals, the remaining sands could be attractive to specialty markets.

## Minerales pesados en materiales finos de desecho producidos en plantas de arenas y gravas en el estado de Indiana

**Resumen**—Hay, en Indiana, más de 170 operaciones de explotación de arenas y gravas de depósitos del Pleistoceno y Holoceno. Al procesar unas 30 millones de toneladas cortas (*short tons*) anualmente se desechan cantidades considerables de materiales finos. El análisis de muestras procedentes de los desechos de gran fino de numerosas operaciones (50+) de todas partes del estado, indican que su contenido de minerales pesados varía desde rastros a más del 10%, con un promedio de 2.5% por peso seco (extraídos con un concentrador rotativo de 18 pulgadas). Muy poco material pesado (0.3%) queda en el producto procesado. Grandes cantidades de desechos finos quedan así desperdiciados en sitios de explotación abandonados, de los que sería fácil recuperar los minerales pesados. Gran parte del norte y centro de los Estados Unidos fue cubierto por la glaciación pleistocena. Si minerales pesados son comunes en estos terrenos, entonces existe el potencial de un vasto recurso.

El análisis de la fracción de minerales pesados indica que contienen ilmenita, granate, circon y otros minerales pesados junto con un 30% a 45% de magnetita. Además se observan trazos de otros minerales económicos, principalmente cromita, monacita y oro. Las proporciones relativas de estos minerales dependen de los detalles geológicos y del procesamiento. Minerales pesados tienden a concentrarse en las fracciones más finas, especialmente en las de <0.175 milímetros. También investigadores anteriores han encontrado cantidad (1%-9.9%) de minerales pesados en las fracciones finas (<0.175 mm). En aquellas muestras que exhiben las concentraciones totales más altas de minerales pesados también suele ser mayor el porcentaje relativo de magnetita.

Cantidad y carácter de la asociación de minerales pesados varía de localidad en localidad y ciertas cuencas fluviales tienden a tener mayor cantidad de ciertos minerales pesados; excavaciones a lo largo de las orillas de dos ríos muestran concentraciones del orden de los 4.5%. En todas partes de Indiana, yacimientos de arena acusan concentraciones de minerales pesados en exceso de 5% en las fracciones finas. Cifras similares se conocen de estados vecinos. Aunque la materia bruta generalmente no contiene minerales pesados en concentraciones económicas, ciertos depósitos podrían producirlos como producto secundario de los materiales finos que al presente se usan como desechos. Una vez depurados de minerales pesados, las arenas restantes podrían cobrar interés económico para usos especiales.

## Introduction

For many years small amounts of placer gold (and some diamonds) have been produced from Indiana stream sediments derived from glacial deposits, particularly along ice-marginal positions. Gold and heavy-mineral occurrences in Indiana were summarized by Blatchley (1903), Logan (1922), Erd and Greenberg (1960), and Hill (1988), who concluded along with Sutton (1882) and Hafner (1921) that gold and accompanying black sands were brought into the Midwest by glacial action. Gunn (1967) questioned foreign origin for diamonds and Westman (pers. comm. 1984) and Hill (1988) also postulated local sources for diamonds. Similar gold and diamond occurrences are found in Ohio (Hanson, 1985; Carlson, 1991; Smith, 1992), Illinois (Lamar, 1968), and other glaciated areas. Virtually nothing is known about the amounts or characteristics of resistant heavy-mineral sands that invariably occur with the gold except for early (Day and Richards, 1906) or anecdotal accounts (Westman, pers. comm. 1984; G. Ziembra, pers. comm. 1993) that report high amounts of monazite, garnet, and zircon. Few efforts have been made to characterize mineral identity, quantity, characteristics, or particle size despite the obvious scientific and economic potentials of the deposits.

In some areas, sand and gravel operators have produced heavy minerals as byproducts of normal mining (Gomes et al., 1979; 1980; Martinez et al., 1981; Rukavine, 1986; Thompson, 1992a,b), and Indiana sand producers have reportedly recovered minor amounts of gold. With increasing uses of rare earths, platinum, titanium, and other commodities won from heavy minerals, it is appropriate to investigate compositions of Indiana sands for the presence of useful heavy minerals. Data of geologic significance obtainable from heavy minerals (i.e. Basu and Molinaroli, 1989; Grigsby, 1992) could elucidate studies of placer formation, mineral provenance, glacial-ice movement, and stream processes.

The presence of heavy minerals in midwestern Quaternary deposits is demonstrated by sedimentological- or glacial-provenance studies in which small samples of unconsolidated materials have been treated with heavy liquids [bromoform with specific gravity (*sp. gr.*) of 2.85] to separate their heavy-mineral suites (Table 1). Lamar and Grim (1937) reported heavy-mineral values for Illinois deposits to range from 0.5 to 9.0 wt.% and to include zircon, titanium minerals, magnetite, zircon, garnet, monazite, and several relatively light silicate minerals.

Krumbein and Rasmussen (1941) noted that a similar suite of heavy minerals comprised from 2.0 to 7.5% of fine (<0.175 mm) fractions of Lake Michigan beach sands, and suggested that concentrations could be found along relict shorelines. Heavy-mineral data for Cretaceous and Tertiary sands of southern Illinois were summarized by Hunter (1968), who reported lower total heavy-mineral percentages of 0.1-1.4, but containing from 46 to 74% ilmenite or leucoxene plus rutile, zircon, monazite, and other heavy minerals.

Heavy minerals are those with *sp. gr.* >2.85. They are commonly minor or accessory rock-forming minerals that are hard and resistant to weathering and transport degradation. They include several economically important industrial minerals such as magnetite, ilmenite, zircon, monazite, garnet, rutile, cassiterite, sphene, plus traces of gold and platinum-group elements. Heavy minerals are typically concentrated and sorted by moving fluids to form placer deposits, but they are dispersed in many nonfluvial sediments.

Early work on heavy minerals used heavy liquids, especially bromoform (*sp. gr.* 2.85), to separate them. Much of that work involved provenance determinations and little attention was given to the economic potential of these minerals. However, the early studies did establish widespread presence of heavy minerals in glacial deposits in the Midwest and the origin of some of these deposits from Precambrian terranes in Ontario and other northern areas, including some with known mineral deposits.

Heavy minerals certainly occur in fine-sand material that is currently being wasted in Indiana and other midwestern states. Production of these byproduct minerals is affected by such factors as the presence of existing sand and gravel mining. Advantages of pre-existing mining operations include the presence of an established infrastructure, machines, mining experience, abundant water, and existing permits. Simple modifications to existing plants could allow recovery of significant amounts of heavy minerals. Numerous abandoned sites exist whose general locations are known and whose exact heavy-mineral-rich waste areas could be easily defined by magnetic or radiometric techniques.

A problem that must be addressed is the unknown variability of grade within these deposits. Most of the heavy minerals examined in this study are relatively fine-grained and may, therefore, present extraction difficulties. Clay minerals in the wastes are also problematic. The largest challenge is the mindset of operators who have limited interest or experience with heavy-mineral markets.

## Procedures

Samples were collected from various parts of sand plants at 61 Indiana commercial operations (Fig. 1) from overflows of sand (classifier) screws or washers (Fig. 2), noted as wash; from waste ponds named delta; and from the concrete sand (#23) product where possible. In several instances, noticeable beds of black sands were sampled and identified as premium. Sampling was done by digging sands from near the surface. Five-gallon buckets were filled with each sample type. A few samples were panned by hand from small streams in Morgan, Brown, and Tippecanoe Counties. One sample from a placer deposit in Ross County, Ohio, studied by Smith (1992) was also examined.

Samples were dried, weighed, and their heavy-mineral fractions were concentrated using an 18 inch spiral

TABLE 1—Some previous studies of heavy minerals in Indiana and surrounding areas.

Author	Location	Heavy mineral percent
Lamar & Grim, 1937	Illinois River/beach	0.3-9.0
Hunter, 1966	Wabash River	1.3-10.5
Hunter, 1968	Southern Illinois-Cretaceous	0.1-1.4
Gunn, 1967	Midwest	No details
Smith, 1992	Ohio	~0-5
Day & Richards, 1906	Indiana beach	Concentrate only
Krumbein & Rasmussen, 1941	Illinois beach	1.9-7.1
Pettijohn, 1931	Lake Michigan beach	0.5-7.5
Dreimanis & Reavely, 1953	Lake Erie till	2-4
Dreimanis et al., 1957	Ontario till	0-14

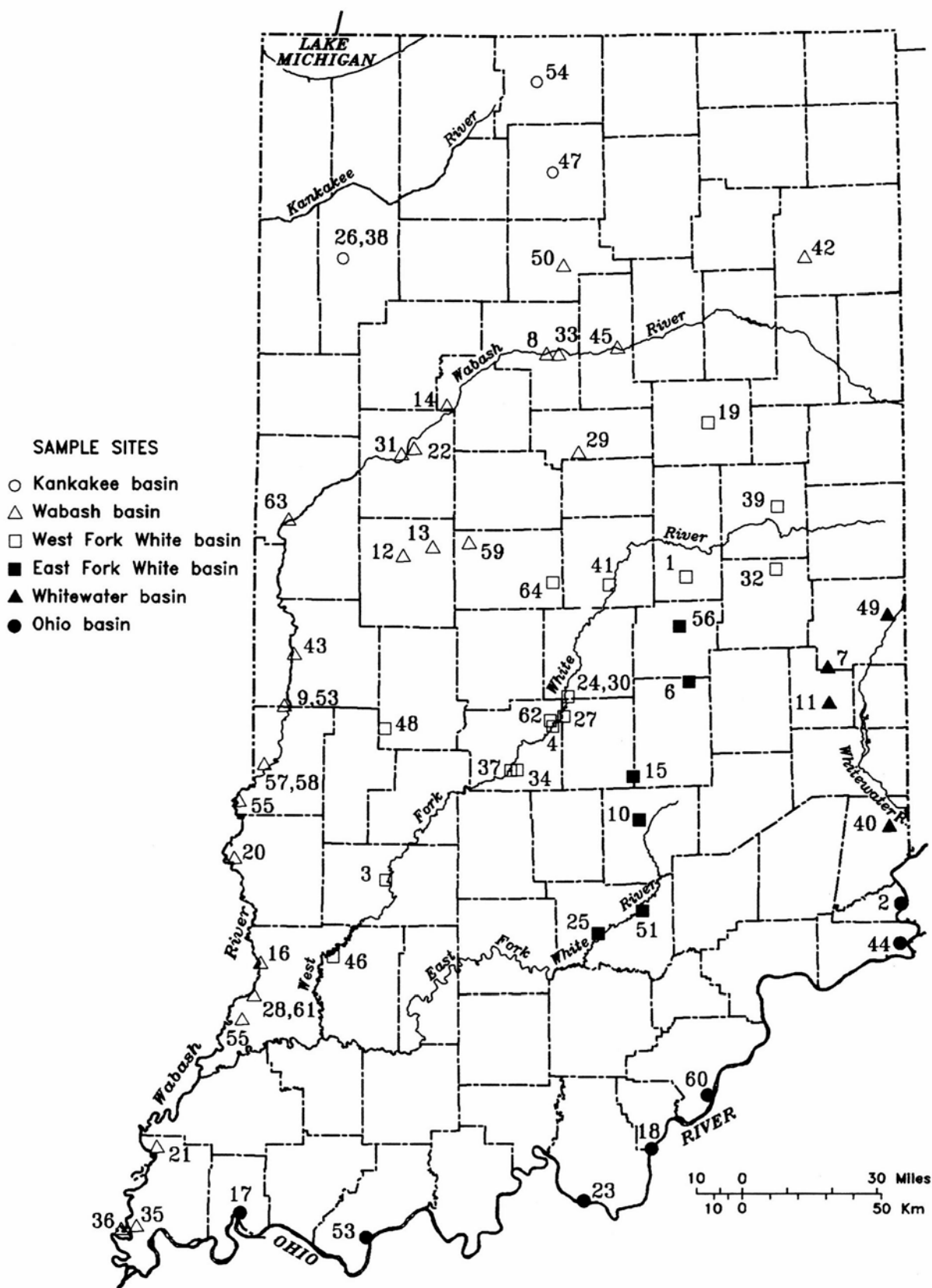

FIGURE 1—Sites of commercial sand and gravel operations sampled for heavy minerals. Symbols relate to general drainage areas.

concentrator (Fig. 3). Data for individual collection sites were reproducible (Table 2A) and one site showed rather constant values for samples collected over a six-year interval (Table 2B). Overall weight percentages of heavy minerals are reported in Tables 3A and 3B. Summaries presented on the basis of drainage areas are in Table 4.

These percentages are probably conservative when compared with previous data derived from heavy-liquid separations. The data represent concentrations from a single pass through the concentrator, and some (20%) recoverable heavies were commonly lost (Table 2C). Because we sampled fine wastes, some heavy minerals of larger grain

TABLE 2—Results of duplicate analyses. **A**, Replicate heavy-mineral analyses of individual samples. **B**, Heavy-mineral percentages in a Marion County site through time. **C**, Heavy-mineral percentage in a sample from single- and multiple-pass concentrations.

<b>A</b>		<b>B</b>			
Duplicates (wt.%)		Year	1988	1994	1994
5.3, 5.4		wt.%	12.6	10.8	11.6
6.1, 6.4					
0.7, 0.9					
0.2, 0.2					
0.1, 0.1					
5.1, 5.4					
3.6, 3.5					
1.0, 0.7					

<b>C</b>		
	1 pass	4 passes
wt.%	1.9	2.4



FIGURE 2—Sand plant showing sand screw. Running water concentrates fine-grained heavy minerals.

TABLE 3—Results of regional sampling. **A**, Heavy-mineral percentages in Indiana fine waste sands. **B**, Summary of heavy-mineral percentages. Tr = trace.

Site number	Location	Wash	Delta	Product	Premium
1	Anderson	0.2	Tr	0.1	
2	Aurora	2.6	2.7	0.1	5.2, 5.9
3	Bloomfield		1.1, 1.2	0.1	
4	Bluff Acres		1.3		
5	Brown County streams				
6	Caldwell	4.8		0.1	
7	Cambridge City	5.3	1.5	Tr	
8	Cass	6.6	Tr	0.5	10.2
9	Clinton	2.6		0.5	
10	Columbus	4.0	1.9	0.2	
11	Connersville	Tr		0.9	4.7
12	Crawfordsville	1.3	0.1	0.3	
13	Darlington			0.5	
14	Delphi	0.3			
15	Edinburg	5.3, 5.4		0.5	
16	Emison	0.4	2.4		
17	Evansville*	0.5, 0.1			
18	Floyd County	2.4		Tr	3.1
19	Gas City	3.2	1.1	0.1	
20	Graysville	7.2			7.7
21	Griffin	0.2	0.4	0.1	
22	Harner	0.6	0.6	0.4	
23	Harrison County	0.4	0.1		
24	Indianapolis*	0.1		0.3	
25	Jackson County	3.6, 3.5	3.4		5.4
26	Jasper County	Tr		Tr	
27	Johnson County IMI	Tr, 1.0, 0.7	1.3	0.2	
28	Knox County			Tr	
29	Kokomo	1.2		0.5	
30	Kopetsky	5.1, 5.4	3.6	0.3	10.8, 12.6, 11.6
31	Lafayette	0.2	0.1		
32	Laurey	0.2	2.9	Tr, 0.3	
33	Logansport	1.9			
34	Martinsville	Tr		0.1	
35	McDonald	3.5		Tr	
36	Merom			0.1	
37	Morgan County	0.4		0.3	
38	Morocco	Tr		0.1, Tr	
39	Muncie*		0.2		
40	New Trenton	1.3	1.4	0.2	
41	Noblesville	0.8		0.3	
42	Old Prairie	1.7		0.1	
43	Parke County			0.1	
44	Patriot			Tr	
45	Peru	Tr		Tr	

TABLE 3—Continued

Site number	Location	Wash	Delta	Product	Premium
46	Plainville	3.6, 3.1	0.2	0.3	
47	Plymouth	0.1		0.1	
48	Reelsville	0.1			5.8
49	Richmond	0.5		Tr	10.9
50	Rochester	0.8			
51	Seymour	1.9		0.2	
52	Shepherdsville	0.8			
53	Spencer County			0.1	
54	St. Joseph	2.8			
55	St. Thomas	0.1, 0.1	0.1	0.1	
56	Strubbe		0.1		
57	Terre Haute (MM)	6.1	6.4	0.3	
58	Terre Haute (S&G)	4.6		1.6	
59	Thornton	0.7	0.1	0.4	
60	Utica	0.1	0.1		
61	Vincennes	0.2			
62	Waverly	0.7		0.2	
63	West Lebanon	0.3	0.1		
64	Zionsville	1.2	1.0	0.9	9.9

\*Reworked material

## B

Type	Number	Range	Average
Raw	(3)	Tr-11	5.0
Washer	(49)	Tr-7.2	2.0
Delta	(25)	Tr-6.4	1.2
Product	(33)	Tr-1.6	0.3
Premium	(9)	Tr-12.6	7.8
All Wash	(58)	Tr-12.6	2.8

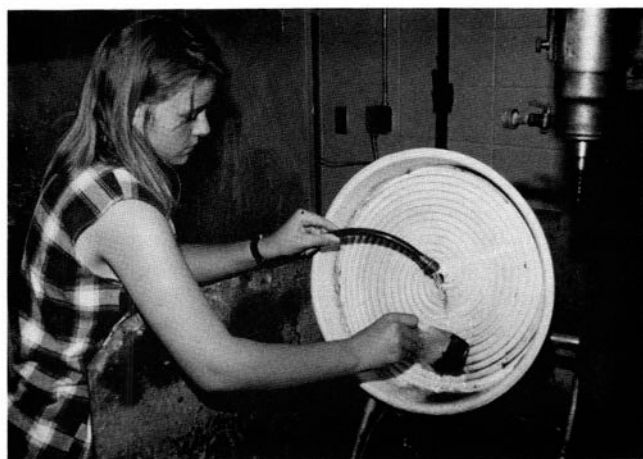

FIGURE 3—Laboratory spiral concentrator. Samples were dried, weighed, and heavy-mineral contents determined. Heavies spiral up the pan and fall through a hole in the central shaft into a collecting pan.

TABLE 4—Heavy-mineral percentages (wt.%) in different drainage areas of Indiana.

Drainage area	Wash	Delta	Product	Premium
East Fork White	4.0	1.8	0.2	5.4
West Fork White	2.0	1.3	0.3	8.7
Wabash	1.9	0.8	0.4	8.9
Ohio	1.5	1.4	0.1	—
Kankakee	0.3	—	0.1	—

size were undoubtedly removed in processing for the coarser-fraction products. Also, many systems were not conducive to adequate sampling procedures. Cyclone-type systems typically did not show appreciable heavy minerals in any fraction measured despite their ubiquitous presence in raw materials.

Several samples were further treated by a Franz magnetic separator to separate fractions of different magnetic properties. Early samples were divided into six magnetic fractions, but experience indicated that a three-part separation gave quicker and quite useful results. Table 5 is a summary of weight percentages for those three magnetic portions that represent (1) magnetite, (2) ilmenite plus garnet, and (3) others. Mineralogy of heavy-mineral suites was determined by X-ray diffraction.

A few samples were analyzed by neutron activation to determine their geochemical composition as summarized in Table 6. In addition, an industry source provided a few general X-ray fluorescence analyses that indicate considerable amounts (19-30%) of titanium and zircon.

Particle-size determinations were made of a few samples using standard methods with sieves and a Ro-Tap machine. Those data are summarized in Figure 4.

## Test results

Almost every operation yielded samples with heavy minerals (Table 3). Heavies occur dispersed in the sands and tills but are concentrated by running water. Raw materials contain trace amounts to about 11% heavies, but typical values appear to be in the 0.5-3% range. Discrete beds rich in black, heavy sands can be seen in most deposits. Heavy minerals are ubiquitous in fine fractions

TABLE 5—Average percentages (wt.%) and ranges of heavy minerals in magnetic fractions by sample types.

Type	(1) Magnetite	(2) Ilmenite & garnet	(3) Others
Raw (3)	57	33	10
Washer (12)	51	22	27
Delta (7)	44	28	28
Product (6)	34	26	40
All (35)	44	29	28
Overall range	(22-72)	(14-50)	(12-70)



TABLE 6—Results of chemical analyses. **A**, Summary of neutron-activation analyses of 25 waste sand heavy-mineral samples from Indiana. Values ppm. **B**, Major elements determined by X-ray fluorescence for three panned samples. Values in wt.%.

A					
Au	Zr	Cr	Ce	U	Th
0->10	1600->10,000	460-1300	50-490	5-47	10-136
6	7620	850	240	14	65
B					
As	Zn	Ni	Co	W	Ag
5-194	200-710	20-120	40-110	2-523	0-16
32	310	65	50	25	1
B					
Fe <sub>2</sub> O <sub>3</sub>	TiO <sub>2</sub>	Zr	Cr <sub>2</sub> O	CeO	P <sub>2</sub> O <sub>5</sub>
56-63	19-34	0.7-1.8	0.1-0.3	0.02-0.05	0.05-0.07
59	23	1.1	0.2	0.03	0.06

of midwestern sands, especially in sand classifier screws and their overflow. Material from these classifiers contained from trace amounts to 7.2% heavy minerals and an average of about 2%. Figure 5 is a summary of heavy-mineral percentages and the histogram shows a distinct bimodal distribution (Fig. 6).

In several cases, discrete beds (up to 2 cm thick) of black sand were noticed in waste-outflow channels. Samples of these were reported as premium and ranged from 1.5 to 12.6 wt.% with an average of 7.8% heavy minerals. Some of these beds appeared red due to abundant garnets.

Waste water and fine-grained materials are frequently washed into the original pit to form a delta. Where possible, samples were taken from these deposits. Heavy minerals were present in delta samples from trace amounts to 6.4% and averaged 1.2%. Concrete sand (#23), a product of intermediate particle size, contained relatively less heavy material and ranged from trace amounts to 1.6% with an average of only 0.3%.

Thirty-five samples were processed by magnetic separation. Our method yielded a mostly magnetite fraction; a secondary fraction of ilmenite, garnet, and other partially magnetic minerals; and a third, essentially non-magnetic group (Table 5). Values ranged from 22 to 72% magnetite with an average of 44%. The partially magnetic group ranged from 14 to 50% and averaged 29%; the nonmagnetics averaged 28% with a range of 12-70%.

Particle sizes for panned material (Fig. 4A) showed a distinct bimodal pattern with much of the heavy fraction in the 9-16 mesh-size range. A second range from 80 to 230 mesh contained about one-third of the heavy minerals. It is this finer fraction of heavy minerals that is concentrated during sand processing as shown by size analyses of washer overflow (Fig. 4B). Much of the large, panned heavy material was of minimal economic value and included magnetite- or iron-oxide-cemented siltstones from the underlying shale bedrock. Previous studies (Krumbein and Rasmussen, 1941; Hunter, 1968) noted the occurrence of heavy minerals in the fine-sand fraction. Apparently economic heavy minerals are sometimes concentrated in the 80-230 mesh portion of midwestern sand deposits. This material could be readily processed to extract heavy minerals of economic significance, especially at existing operations. Even with no

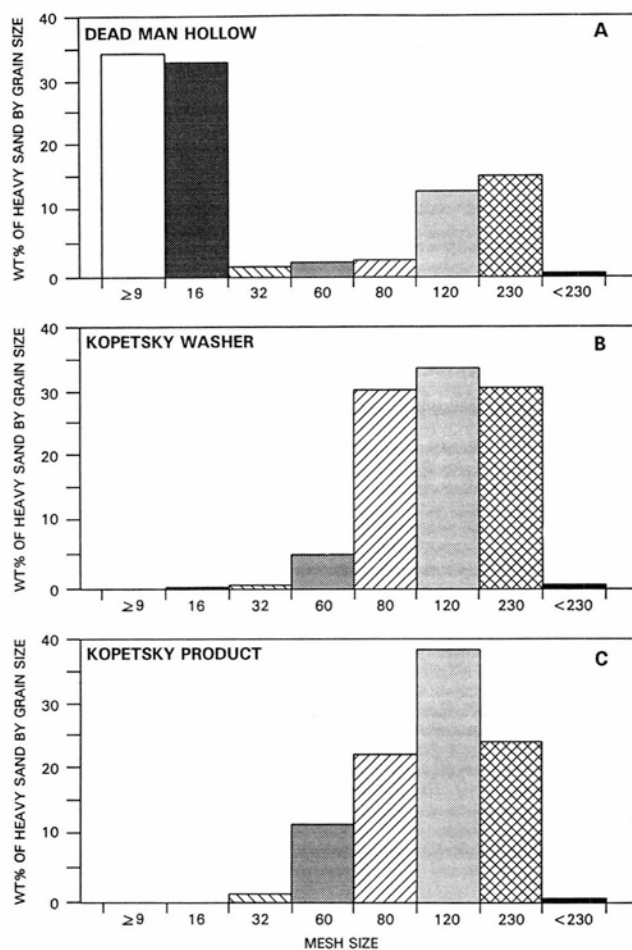

FIGURE 4—Histograms showing **A** heavy-mineral particle-size distributions of panned samples; **B** wash sample; and **C** product.

efforts to optimize their concentration, the heavies appear to be concentrated to impressive values in waste sands.

While these percentages may at first appear to be small, they are near those considered minable. Garnar (1981) gave values of 3-4% titanium-rich heavy minerals from deposits in the southeastern United States, and Grosz et al. (1990) cited values in the 3-6% range for worldwide deposits. Carpenter and Carpenter (1991) noted heavy-mineral values of 3.5-7.0% in potentially mineable deposits of the Atlantic Coastal Plain, whereas Davis and Sullivan (1971) found average values of 0.5-2.8% heavies, and Cochran and Smith (1972) reported 0.6-1.6% heavies in sand and gravel samples from that area.

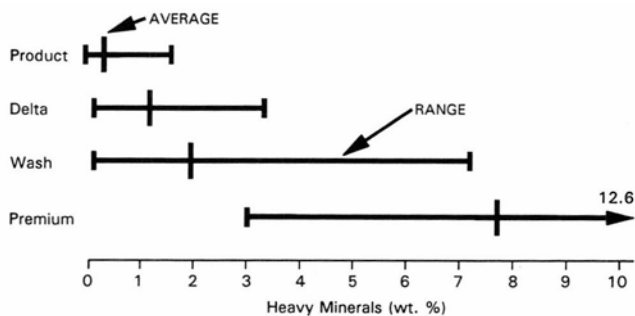

FIGURE 5—Ranges and averages of heavy minerals in different sample types.



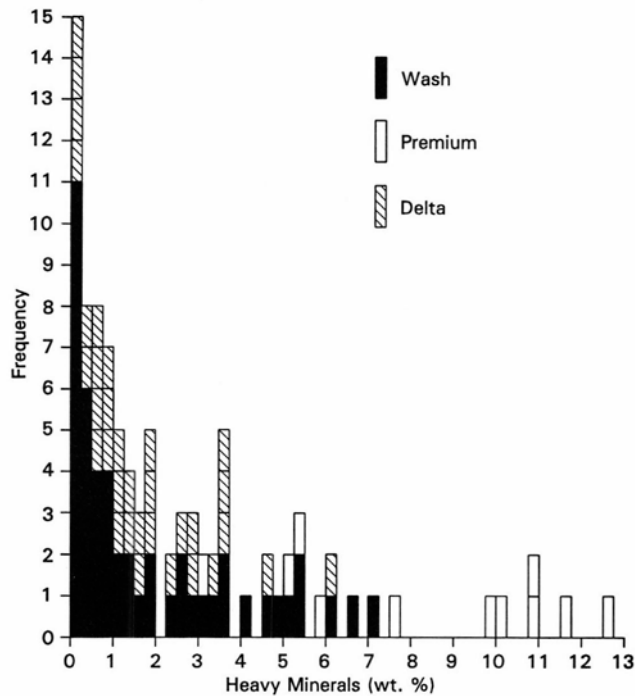

FIGURE 6—Histogram of heavy-mineral percentages showing multiple modes.

Heavy-mineral suites in Indiana are dominated by magnetite, but substantial amounts of ilmenite, garnet, zircon, monazite, and chromite have been noted. Rutile, lucoxene, spinel, and tourmaline also commonly occur. Pyrite is present in a few samples, but sulfides are generally scarce. Traces of gold and a number of other minerals are observed in most samples. Detailed study and quantification of heavy minerals remain to be completed, but economically useful materials are abundant in the waste sands sampled thus far.

Geochemical data from commercial neutron-activation analyses (Bondar—Clegg) confirm gold and other economic materials (Table 6A). Gold values average more than 7 ppm for samples analyzed to date, but this value is conservative because eight of the samples contained more than the 10 ppm upper detection limit of BondarClegg's analytical technique. Zirconium (average 7,600 ppm), chromium (850 ppm), rare-earth elements, uranium, and thorium are also present in considerable amounts, as would be expected. Very little silver was measured and no data are yet available for platinum-group elements. Limited chemical data by X-ray fluorescence (Table 6B) confirm the presence of titanium-bearing materials.

#### Heavy-mineral potential

Much of the northern United States was glaciated by the Laurentide ice sheet which covered more than  $13 \times 10^6$  km<sup>2</sup> of North America (Flint, 1971) and left glacial deposits over nearly four-fifths of Indiana. The ice sheet also transported and deposited ice-entrained debris over most of the northern tier of states. If all glaciated regions contain heavy minerals in sand and gravel deposits, the potential for meaningful production of commercially viable heavy minerals improves when compared with possible production from a single state.

Indiana has produced 16-26 million metric tons (mt) of sand and gravel annually since 1959 except during

the recession of 1981-84. A reasonable estimate of heavy minerals in waste material would require knowledge of the amount of fine-grained materials in the deposits. Several operators estimate that 15-20% of the total throughput is fine-grained waste, and even higher percentages of fines are reported by some (Patton, 1953, as reported in Carr and Webb, 1970). Assuming 20% fines and 23 million mt of production, an estimated 4.5 million mt of waste is produced annually in Indiana. Similar amounts are likely available in other glaciated states.

#### Conclusions

Potentially significant amounts of heavy minerals occur in sand deposits of glaciated regions of Indiana and other midwestern states. Values range from near zero to 12.6% and average more than 2%. Economic heavy minerals appear to become concentrated in currently discarded fine sand (<0.175 mm) fractions of existing commercial plants. Ilmenite, garnet, zircon, and monazite are common components of the heavy minerals, in addition to easily separated magnetite. Several positive factors enhance heavy-mineral-coproduction possibilities, but much more information is needed to define this newly recognized resource.

#### References

- Basu, A., and Molinaroli, E., 1989, Provenance characteristics of detrital opaque Fe-Ti oxide minerals: *Journal of Sedimentary Petrology*, v. 59, pp. 922-934.
- Blatchley, W. S., 1903, Gold and diamonds in Indiana: Indiana Department Geology Natural Resources, Annual Report 27, pp. 11-47.
- Carlson, E. H., 1991, Minerals of Ohio: Ohio Geological Survey, Bulletin 69, 155 pp.
- Carpenter, R. H., and Carpenter, S. F., 1991, Heavy mineral deposits in the upper Coastal Plain of North Carolina and Virginia: *Economic Geology*, v. 86, pp. 1657-1671.
- Carr, D. D., and Webb, W. M., 1970, Sand and gravel resources of Indiana: Indiana Geological Survey, Bulletin 42-D, 31 pp.
- Cochran, W., and Smith, R. L., 1972, Availability of ruffe as a product from sand-washing plants in the southeastern United States: U.S. Bureau of Mines, IC-8540, 27 pp.
- Day, D. T., and Richards, R. H., 1906, Investigation of black sands of the Pacific slope: U.S. Geological Survey Professional Paper, pp. 1175-1246.
- Davis, E. G., and Sullivan, G. V., 1971, Recovery of heavy minerals from sand and gravel operations in the southeastern United States: U.S. Bureau of Mines, RI 7517, 25 pp.
- Dreimanis, A., and Reavely, G. H., 1953, Differentiation of the lower and upper till along the north shore of Lake Erie: *Journal of Sedimentary Petrology*, v. 23, pp. 238-259.
- Dreimanis, A., Reavely, G. H., Cook, J. B., Knox, K. S., and Mouth, F. J., 1957, Heavy mineral studies in tills of Ontario and adjacent areas: *Journal of Sedimentary Petrology*, v. 27, pp. 148-161.
- Erd, R. C., and Greenberg, S. S., 1960, Minerals of Indiana: Indiana Geological Survey, Bulletin 18, 73 pp.
- Flint, R. F., 1971, *Glacial and Quaternary Geology*: John Wiley and Sons, New York, 892 pp.
- Gamar, T. E., Jr., 1981, Heavy mineral industry of North America; in Coope, B. M. (ed.), *Fourth Industrial Minerals International Congress*: Surrey, U.K., Metals Bulletin PLC, pp. 29-41.
- Comes, J. M., Martinez, G. M., and Wong, M. M., 1979, Recovering byproduct heavy minerals from sand and gravel, placer gold, and industrial minerals operations: U.S. Bureau of Mines, RI 8366, 29 pp.
- Gomes, J. M., Martinez, G. M., and Wong, M. M., 1980, Recovery of byproduct heavy minerals from sand and gravel operations in central and southern California: U.S. Bureau of Mines, RI 8471, 20 pp.

- Grigsby, J. D., 1992, Chemical fingerprinting in detrital ilmenite: *Journal of Sedimentary Petrology*, v. 62, pp. 331-337.
- Grosz, A. E., Berquist, C. R., Jr., and Fischler, C. T., 1990, A procedure for assessing heavy-mineral resources potential of continental shelf sediments; in Berquist, C. R., Jr. (ed.), *Heavy minerals-Virginia inner continental shelf*: Virginia Division of Mineral Resources, Publication 103, pp. 13-30.
- Gunn, C. B., 1967, Provenance of diamonds in the glacial drift of the Great Lakes Region, North America: Unpublished MS thesis, University of Western Ontario, London, 132 pp.
- Hafner, C., 1921, Placer gold in Indiana: *Engineering Mining Journal*, v. 111, p. 1023.
- Hanson, M. C., 1985, Gold in Ohio: *Ohio Geology Newsletter*, Spring 1985, 8 pp.
- Hill, J. R., 1988, Gold and diamonds in Indiana an update: *Indiana Geological Survey, Circular 12*, 56 pp.
- Hunter, R. E., 1966, Heavy minerals in sands along the Wabash River: *Illinois Geological Survey, Circular 402*, 22 pp.
- Hunter, R. E., 1968, Heavy minerals of the Cretaceous and Tertiary sands of extreme southern Illinois: *Illinois Geological Survey, Circular 428*, 22 pp.
- Krumbein, W. D., and Rasmussen, W. C., 1941, The probable error of sampling beach sand for heavy mineral analysis: *Journal of Sedimentary Petrology*, v. 11, pp. 10-20.
- Lamar, J. E., 1968, Gold and diamond possibilities in Illinois: *Illinois Geological Survey, Open-file Report*, 21 pp.
- Lamar, J. E., and Grim, R. E., 1937, Heavy minerals in Illinois sands and gravels of various ages: *Journal of Sedimentary Petrology*, v. 7, no. 2, pp. 78-83.
- Lamar, J. E., and Shrode, R. S., 1954, Heavy minerals in Illinois glacial sands: *Illinois Geological Survey, Industrial Mineral Note No. 1*, 3 pp.
- Logan, W. N., 1922, Gold in Indiana: *Indiana Department of Conservation Yearbook for 1921*, pp. 227-235.
- Martinez, G. M., Gomes, J. M., and Wong, M. M., 1981, Recovery of byproduct heavy minerals from sand and gravel operations in Oregon and Washington: *U.S. Bureau of Mines, RI 8563*, 14 pp.
- Pettijohn, F. J., 1931, Petrology of the beach sands of southern Lake Michigan: *Journal of Geology*, v. 39, pp. 432-455.
- Rukavine, M., 1986, There's still plenty of gold in those aggregate deposits: *Rock Products*, January, pp. 25-26.
- Smith, K. C., 1992, Source and occurrence of placer gold in central Rosa County, Ohio: Unpublished MS thesis, Ohio State University (Columbus), 169 pp.
- Sutton, G. B., 1882, The gold-bearing drift of Indiana: *American Association for Advancement of Science, Proceedings*, v. 30, pp. 177-185.
- Thompson, J. V., 1992a, Byproduct gold from construction aggregates: *Engineering and Mining Journal*, June 1992, pp. 49-52.
- Thompson, J. V., 1992b, Mining gold from aggregate deposits: *Rock Products*, Part 1, November, pp. 41-44; Part 2, December, pp. 50-54.

# Geology of resources for crushed-stone aggregate in Arkansas

Stephen W. Kline

*Center for Energy, Natural Resources, and Environmental Studies, Arkansas Tech University, Russellville, Arkansas 72801, USA*

**Abstract**—The Arkansas Center for Energy, Natural Resources, and Environmental Studies, has begun a study to bring together information from various sources to evaluate resources for crushed-stone aggregate in the state. Several factors may influence an increasing demand for crushed stone in the near future. The population is growing, especially in the northwestern part of the state. There are tentative plans for a north–south interstate highway for the western part of Arkansas. The southern and eastern parts of Arkansas are devoid of hard rock and depend on gravel deposits for aggregate. At present, the state highway department's (AHTD) requirements for asphalt pavement can be barely met by these gravels. If the Strategic Highway Research Program recommendations for asphalt mixtures are implemented, the presently marginal gravel deposits will become totally inadequate, and this deficiency will have to be taken up by shipping more crushed stone from the Paleozoic region of the state.

One goal of the present study is to determine the geologic mapping units that are being, or historically have been, quarried in the state for crushed stone, and to evaluate the relative quality of these units. From records of the federal Mine Safety and Health Administration, the U.S. Army Corps of Engineers, and the AHTD, the locations of nearly 350 present and past quarry sites have been plotted on Arkansas Geological Commission Geologic Worksheets (reconnaissance bedrock maps on 7.5 minute quadrangles). For approximately half of these sites, the Corps of Engineers and the AHTD have records of quality-control tests that have been done over the years. Compilation of these test results is still in progress.

Preliminary results from analysis of test data from 40 presently active quarries show some distinct trends. In the northern part of the state crushed stone is being produced from limestones (Pitkin, Fernvale/Kimmswick/Plattin, and Boone Formations), dolomites (Cotter, Powell, and Everton Formations), and sandstone (Bloyd and Hale Formations). The limestones rarely have trouble passing AHTD requirements for higher-quality aggregates (Los Angeles [LA] Abrasion Test, 40% loss; Sodium Sulfate [SS] Soundness Test, 12% loss), but the dolomites, while usually scoring excellent on the abrasion test, often fail the soundness test (36% failure rate). The Bloyd/Hale sandstones normally fare well on both tests, but one quarry is in a marginal occurrence. In the Arkansas River Valley area sandstone is produced from the Atoka and Hartshorne Formations. The many Hartshorne and Atoka quarries consistently return excellent results on both tests, though one Atoka quarry has frequent failure of the LA Abrasion Test. In the Ouachita section another sandstone from the Jackfork Formation has results similar to the Hartshorne and Atoka sandstones. One active quarry in the Ouachitas utilizes the Arkansas Novaculite. The abrasion and soundness results are good, and novaculite scores well on polish tests performed in Texas and Louisiana where much of it is marketed. However, the novaculite is hard on mining and crushing equipment. Arkansas' highest quality stone is produced from syenite plutons near Little Rock, and large volumes of this rock remain. Another igneous rock, the Hatton Tuff of the lower part of the Stanley Formation, has only recently begun to be exploited. Where unweathered, it is a superior-quality stone that scores well on abrasion and soundness tests. It also ranks in the highest class defined by Texas polish tests. Its geographic location near the southwestern limit of Paleozoic rocks makes it well positioned for the growing needs of the Gulf Coast region.

## Geología de rocas para agregado de piedra molida en Arkansas

**Resumen**—El Instituto de Investigaciones Mineras y Minerales del estado de Arkansas ha iniciado un estudio para reunir información de fuentes diversas con el fin de evaluar materia prima para agregado de piedra triturada en el estado. Hay varios factores que podrían afectar una creciente demanda para piedra molida en un futuro cercano. La población está en aumento, especialmente en el noroeste del estado. Hay planes tentativos para una carretera interestatal norte–sur en el oeste de Arkansas. Las partes sur y este de Arkansas carecen de afloramientos de roca Jura y para agregado dependen de yacimientos de grava. En la actualidad, esos depósitos de grava apenas pueden satisfacer la demanda que el Departamento de Carreteras de Arkansas (AHTD) tiene para pavimento de asfalto. En caso que se pongan en práctica las recomendaciones para mezclas de asfalto dadas por un *Programa de Investigaciones de Carreteras Estratégicas* los depósitos de grava, de calidad marginal al presente, serán totalmente inadecuados, y deberá remediarse esa deficiencia trayendo más roca triturada de la región de formaciones paleozoicas del estado.

Uno de los objetivos del presente estudio es identificar las formaciones geológicas que en el presente o pasado han sido explotadas para roca triturada y determinar su calidad relativa.

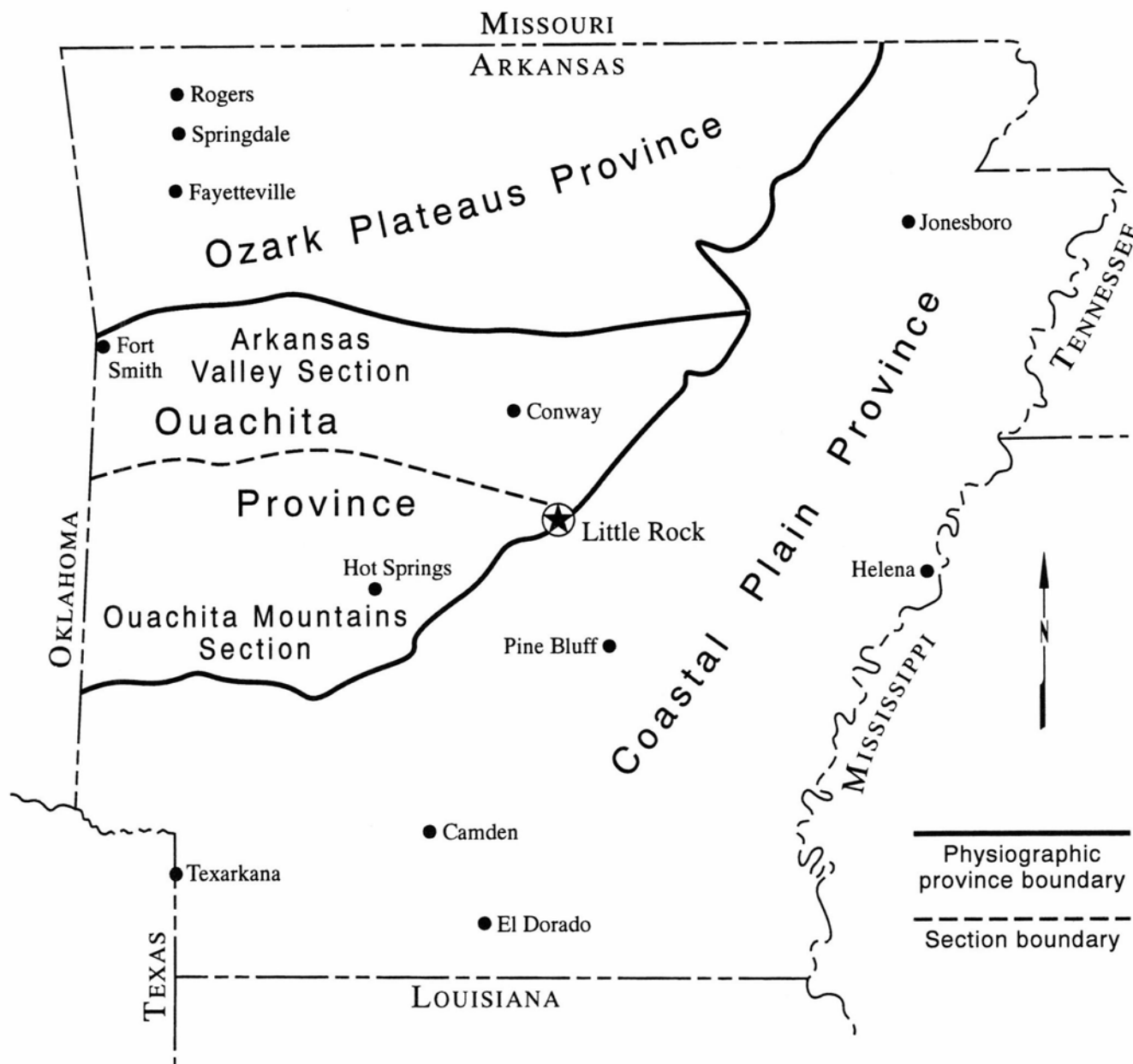

FIGURE 1—Map of Arkansas showing physiographic divisions. Well-lithified Paleozoic sedimentary rocks occur in the Ozark Plateaus province and in the Ouachitas province. Generally poorly lithified Cretaceous and younger sediments occur in the Coastal Plain province. Alkalic plutons are scattered in the area between Little Rock and Hot Springs.

records received from the AHTD and the Corps of Engineers, because for many of the quarry sites they have obtained engineering test data on the rock. Nearly 350 quarry locations have been acquired from these sources, but a number of ambiguous locations have yet to be resolved by field checking. Approximately half of the sites have records of quality-control tests. Locations are being plotted on USGS 7.5 minute topographic quadrangles. To determine the geologic unit in which a quarry occurs, the location is transferred to the corresponding Arkansas Geological Commission (AGC) Geologic Worksheet. AGC Geologic Worksheets are reduced-size 7.5 minute topo sheets with the boundaries of geologic mapping units drawn on them. Geologic Worksheets are available for nearly all the quadrangles that cover Paleozoic bedrock in Arkansas. The worksheets are based on compilation of

map data generated over many years by various workers mapping at scales from detailed to reconnaissance.

At present, engineering test data from 40 accurately located active quarries that regularly submit samples to the AHTD have been compiled and evaluated. Compilation of AHTD data on inactive quarries is still being conducted. Corps of Engineers data have been obtained but not yet analyzed. Progress in compilation of data from abandoned quarry sites is slow because many of the records are tied to the quarry operator rather than the site; and because sites have often changed hands through the years, sorting out applicable data is difficult.

The quantitative data used to compare the rock units consist of the "Los Angeles Abrasion Test" (AASHTO T-96) and "Sodium Sulfate Soundness Test" (AASHTO T-104). Although other factors are evaluated for acceptance

of stone for highway construction aggregate, these two quality tests are widely used by AHTD for acceptance (Arkansas Highway and Transportation Department, 1993), and suppliers that bid for AHTD jobs must submit samples on a yearly basis and have these parameters evaluated. The LA Abrasion Test is a measure of the stone's durability. Stone sieved to a specified size grading is tumbled in a drum and the amount of material lost by degradation of the stone under this process is measured. An abrasion loss of no more than 40% is allowed in aggregate for most asphalt surface course applications and for portland cement concrete (PCC) for rigid pavement and for structures. The SS Soundness Test simulates freeze-thaw conditions. Stone of a specified size grading is soaked in a solution of sodium sulfate and then dried in an oven. The absorbed sodium sulfate crystallizes and simulates the expansion of freezing water. This process is repeated five times and total loss by stone degradation is measured. For both asphalt and PCC applications the AHTD allows no more than 12% loss in this test.

In order to compare test data from quarries in different rock units, the data have been plotted on histograms. A problem to consider in this analysis is that operators who differ in degrees of competency work the various quarries in a particular rock unit. In spite of this, when AHTD test data are compared from a number of quarries that produce from the same rock unit, fairly consistent trends can be seen. Space here does not permit showing the data from each individual quarry. There is also quite a bit of consistency among different geologic map units that are of similar rock type. For example, sandstones are quarried from four different formations. The variation from quarry to quarry in one of these formations is quite similar to the variation seen in the other sandstone-bearing formations. With the data compiled so far, it is easier to make distinctions based on rock type than on geologic formations. Therefore, to conserve space, the data presented in this report combine quarries that are in the same rock type (Fig. 2). When more data are assembled, it may be possible to make distinctions among formations of similar rock type.

#### Comparison of aggregate source rock by region

The geologic units that are being worked in the 40 active quarries thus far analyzed are discussed by physiographic region (Fig. 1). The various regions tend to have contrasting rock types and/or other characteristics such as transportation access that make discussion by region useful.

#### Ozark region (northern Arkansas)

The northern Arkansas region is characterized by lower to middle Paleozoic carbonates (both dolomite and limestone) with nearly horizontal bedding. Other sedimentary rocks occur in lesser quantities, and the carbonates constitute the principal rock types quarried in that part of the state. In the eastern part bordering on the Arkansas River Valley, sandstones in the Bloyd and Hale Formations are also utilized. Because of their proximity to the Arkansas Valley area, and because the rocks quarried from the Bloyd and Hale are similar in lithology to many rocks quarried in the Arkansas Valley and Ouachita area, they are discussed with those areas.

**Limestones**—Eight quarries are presently operating in Limestones—six in the Boone Formation, one in the Pitkin Limestone, and one in a composite section that includes the Fernvale, Kimmswick, and Plattin Limestones. The

limestones rarely have trouble passing AHTD requirements for higher quality aggregates. Though some variation from quarry to quarry is evident, the data are insufficient to decide whether any one of these limestones is better than the others. A histogram showing variation in test data for all limestone quarries combined is included in Figure 2.

**Dolomite**—Dolomite aggregate is produced from nine quarries—two in the Cotter Dolomite, five in the Powell Dolomite, and two in the Everton Formation. None of the samples from dolomite quarries have failed the LA Abrasion Test (Fig. 2), but all the quarries have had some problem with passing the SS Soundness Test (though some quarries have fewer problems than others). Taking all the data together, a 36% failure rate occurs. As with the limestone, on the whole the various dolomite units do not show differences that would make any one dolomite unit more attractive.

X-ray diffraction analysis was conducted on some Cotter Dolomite samples from Missouri that consistently had problems on the SS Soundness Test, and it was found that the dolomite had significant amounts of clay (David Lumbert, AHTD Research, pers. comm. 1995). Perhaps clays in the dolomites are responsible for the frequent failure to pass the SS Soundness Test. Some quarries in dolomite have levels that consistently return better SS Soundness Test results than other levels in the same quarry. For example one quarry consistently passed on soundness only with stone from a stratigraphic interval of a few meters straddling a mineralized contact between the Powell and Cotter Dolomites. It would be helpful to the stone industry in that part of the state if a systematic study could be done that would determine the specific cause of soundness failure in the dolomites and whether there is a consistent stratigraphic relationship or an easily recognized petrographic feature that could differentiate between passing and failing dolomite.

Another difficulty commonly encountered in Arkansas with dolomite, and to some extent also with micritic limestones such as the Plattin and Kimmswick, is with AHTD specifications on "dust ratio" in base-course aggregate. Stone for base aggregate does not have to pass the SS Soundness Test but must pass the LA Abrasion Test, so in this regard the dolomites are excellent for base (Fig. 2). However, when crushing dolomite to get the necessary size grading for base, an excess of fines relative to sand-sized particles often occurs. The AHTD requires that the fraction passing the #200 sieve does not exceed the total passing the #40 sieve (this is the dust ratio). To remedy the problem, sand is commonly hauled in and mixed with the aggregate to lower the relative proportion of dust. An innovation used by at least one operator to deal with the problem is to mix in a portion of St. Peter Sandstone, an extremely friable local sandstone. In the quarry with the micritic Plattin and Kimmswick Limestones, a portion of the overlying Fernvale Limestone, a coarse grainstone that makes abundant sand-size particles when crushed, is mixed in.

**Need for siliceous material in northern Arkansas**—Another problem that is peculiar to the Ozark region stems from the low hardness (Mobs Scale 3-4) of carbonate rocks. For asphalt surface course applications, the AHTD requires the aggregate to have at least 40% siliceous material (no more than 60% dolomite or limestone). This is because dolomite and limestone tend to polish rapidly during road wear, and asphalt with carbonate rock as the sole aggregate tends to become slick with time. Tradition-

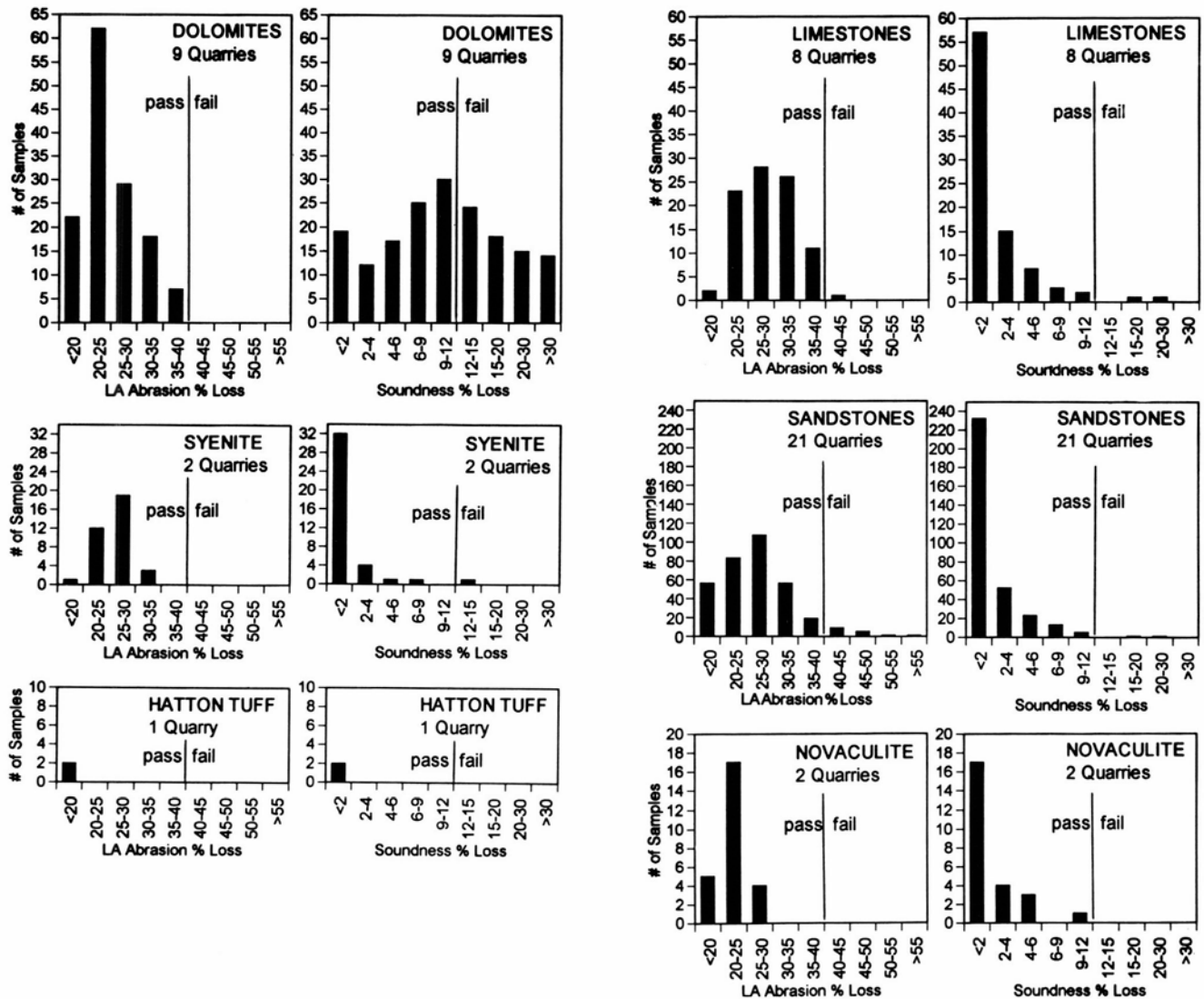

FIGURE 2—Histograms of AHTD test data (LA Abrasion and SS Soundness Tests). Data from quarries in similar rock types are combined. Values for passing/failing are indicated.

ally, local stream gravels have been dredged for siliceous material to supplement the carbonate aggregate in order to meet this specification. In recent years legislation has been enacted to eliminate mining of sand and gravel from a number of rivers in this scenic area prized for outdoor recreation activities such as boating and fishing. At the time of this writing, further legislation is being considered that would strengthen enforcement of these laws and increase regulation in streams where mining is permitted. Low availability of siliceous material for asphalt mixes has already led to shipping of crushed sandstone from the Arkansas River Valley area and chert from Oklahoma into northwest Arkansas, driving up costs for construction aggregate.

Future construction costs will be even higher if suitable local sources for siliceous aggregate are not found. Some harder portions of the St. Peter Sandstone have been tried, but without success. In order to be accepted by AHTD as "siliceous material," the portion retained on the #10 sieve must have insoluble residue of at least 85% when tested in a 1:1 solution of glacial HCl and water. The St. Peter Sandstone is cemented with calcite and too much of the total rock mass dissolves. Diagenetic chert occurs in some parts of carbonate formations, particularly in the Boone

Formation. In many places the chert in the Boone is tripolitic and contributes soft particles unacceptable in asphalt and PCC mixes. In aggregate for base course, an overabundance of tripolitic chert can cause the aggregate to fall short of the required compacted bulk density due to the low density of the porous tripoli. However, chert in some parts of the Boone is hard. It would be helpful to northern Arkansas if areas with enough durable chert in the Boone (or other formations) could be located.

#### Arkansas River Valley and Ouachita region (central Arkansas)

**Sandstones**—The most common rock type quarried for construction aggregate in the Ouachita Mountains, Arkansas River Valley, and neighboring southeast portion of the Ozarks is sandstone. In the southern Ozarks five quarries are active in the Bloyd Shale and the upper portion of the Hale Formation (units thus combined on AGC Geologic Worksheets and the *Geologic Map of Arkansas* [Haley et al., 1993]). In the Arkansas River Valley area, there are five active quarries in the Atoka Formation and seven in the Hartshorne Formation. In the Ouachitas, three quarries are active in the Jackfork Sandstone. Engineering test data for these sandstone units are quite similar. All the sand-

stone units show consistently good results on the SS Soundness Test, with very rare failure. Most quarries obtained good results on the L.A. Abrasion Test, but some problems with abrasion showed up in one quarry out of each of the Boyd / Hale, Atoka, and Jackfork Formations. Figure 2 shows a histogram of data from the sandstone units collectively. The positions of some Hartshorne Sandstone occurrences on the navigable Arkansas River are ideal for long-distance transport of stone to locations near the Arkansas and Mississippi Rivers that lack local aggregate sources.

A fairly consistent problem for quarries in the sandstone units is the presence of shale layers. Shale is the most common problem in Arkansas quarries, because so much of Arkansas' aggregate resources are in sedimentary rocks. The Boyd/Hale and Hartshorne sandstones are fluvial in origin, and the Atoka sandstones (in the areas where they are quarried) are deltaic. The Jackfork is interpreted as having been deposited in submarine-fan environments, with its massive sandstones representing fan channel deposits. Facies changes in any of these can unexpectedly introduce shale layers as quarrying proceeds. Operators must constantly keep a watchful eye for shale because even small amounts are unacceptable under AHTD specifications.

Concerning the Hartshorne Sandstone and Jackfork Formation, the state geologic map (Haley et al., 1993) and the AGC Geologic Worksheets would be useful in exploration for new quarry sites because major parts of these formations are composed of sandstone. However, the same maps would be of limited value in seeking to find new sites in the Atoka or in the Boyd and Hale Formations. These units are dominated by shales with lesser amounts of interlayered sandstone, although some sandstone horizons are thick enough to support stone quarries. The sandstone-bearing horizons are not designated on these maps. Maps showing sections of these units with distinction of rock type would be more useful, such as for the Atoka Formation in the central part of the Arkansas River Valley on the geologic maps of Merewether (1967) and Merewether and Haley (1969).

Igneous rocks— Nepheline-bearing syenite has been a long-standing resource for construction aggregate in the Little Rock area, and other occurrences that could be used are near Hot Springs (the Magnet Cove intrusive complex). Intrusive bodies near Little Rock are ideally located for the steady construction business in that urban center, as well as being close to the Arkansas River and to major rail lines. The stone from these bodies is excellent (Fig. 2), and because of the large size of the plutons the quarries are devoid of shale problems. There are still large reserves of these rocks for the future.

A relative newcomer to the aggregate scene in Arkansas is the Hatton Tuff, a Mississippian pyroclastic rhyolite in the lower portion of the Stanley Formation. This unit occurs predominantly in the southwestern portion of the Ouachitas, but it has also been found near Hot Springs. The unit is up to 40 m thick (and, being in the Ouachitas, dips moderately to steeply in most places). Not many test data are available on the Hatton Tuff from the AHTD (Fig. 2) because it has only recently begun to be utilized, and also because most of it has been shipped out of state. The data from AHTD look excellent, and similar tests done in Texas and Louisiana also indicate that this is a superior-quality stone. In addition to abrasion and soundness tests, both Texas and Louisiana require a pol-

ish test to determine the stone's potential for becoming slick after much tire wear. Many rocks do not score well on this test; however, samples from the Hatton Tuff have scored consistently in the highest category established by this test (Chen Fu, Texas Department of Highways and Public Transportation, pers. comm. 1995). Location on the southern tier of hard Paleozoic rock in the Ouachitas makes this rock unit well situated for the growing demand in south Arkansas, Louisiana, and Texas (however, Jackfork Sandstone and Arkansas Novaculite occur in this area as well, so the Hatton Tuff is not the only usable rock in the area).

Some confusion exists regarding the stone produced from the single quarry operating in the Hatton Tuff near Hatton, Arkansas. Samples of weathered Hatton Tuff from somewhere had been tested by the AHTD sometime in the past with poor results, giving the rock unit a poor reputation at the highway department. Later, when the quarry near Hatton began to supply rock from the Hatton Tuff (the test results of which are shown in Figure 2), a notion developed that the quarry was not actually in the Hatton Tuff but only near it. The rock from that quarry was thought to be a fine-grained syenite (trachyte) dike, a freak occurrence in some way genetically related to the Cretaceous syenite intrusives near Little Rock. Perhaps this concept arose because the fresh rock from the quarry looks quite different from the weathered rock, or perhaps because some of the rock in the quarry has a massive texture rather than one typical of tuffs. For whatever reason the notion arose, it is important to know whether the rock is a trachyte dike or the Hatton Tuff. The rock from that quarry makes excellent aggregate for a variety of applications. If the quarry is in a dike, then it will be difficult to locate another such deposit because it is a random occurrence. If it is the Hatton Tuff, then other occurrences are predictable because the unit has been mapped as a stratigraphic horizon through several counties in Arkansas and Oklahoma (Miser and Purdue, 1929).

To clarify whether the rock is the Hatton Tuff or an intrusive rock, the quarry was visited in early 1995. Several lines of evidence demonstrate that this rock is indeed the Hatton Tuff. The pit follows the easterly strike of the Hatton Tuff as mapped by Miser and Purdue (1929). The southern contact of the igneous body with the Stanley Formation is exposed in a highwall. Bedding in the Stanley near the contact has a strike of N77°E and a dip of 42°S. The beds are graded and show a complete Bouma sequence (Fig. 3) which indicates that they are not overturned. No sign of discordance in orientation with regional bedding was found in the southern contact between the igneous rock and the Stanley sedimentary rock.

Because the southern contact appears to be conformable and local bedding is not overturned, this contact is the stratigraphic "top" of the igneous body. The igneous rock in the upper 10-15 m (rough approximation) is massive and aphanitic. The northern (lower) contact with the Stanley also appears to be conformable. The rock in the lower part of the unit has abundant phenocrysts of feldspar and quartz and centimeter-size dark clots of chlorite-like material, some of which have feldspar phenocrysts in them. Most of the dark clots are flattened, giving the rock a texture that looks like the eutaxitic texture of a pyroclastic rock (the chlorite-like clots representing flattened pumice, but now altered). This stratigraphy of the rock unit quarried near Hatton matches exactly that described by Niem (1977) for the Hatton Tuff: a lower zone





FIGURE 3—Stanley Formation graded bed with a complete Bouma sequence a few meters above the contact with the underlying igneous rock. Photo taken on a nearly east-west-trending highwall on the south edge of a quarry in the Hatton Tuff.

rich in crystals and flattened pumice (replaced by celadonite, the actual mineral that resembles chlorite in these rocks), and an upper zone of fine aphyric tuff.

The final proof that the rock is Hatton Tuff and not an intrusive dike is that thin sections made from the quarry rock (Fig. 4) show abundant bubble-wall shards (glass replaced pseudomorphically by feldspar). Shard-rich textures like this can only be produced in extrusive, pyroclastic igneous rocks (Ross and Smith, 1961), not in intrusions, and the texture matches exactly that described by Niem (1977) for the Hatton Tuff.

**Other rocks**— One quarry presently operates in the Arkansas Novaculite and another quarry recently stopped production in that unit. Novaculite is a form of recrystallized chert, a microcrystalline quartz with a grain size somewhat coarser than common chert. As such it is a very hard, durable material (in places where it is not tripolitic), as demonstrated by the engineering test data (Fig. 2). This stone also performs well on polish tests, and large volumes have been exported to Texas and Louisiana because of its quality and advantageous geographic location. However, its highly abrasive nature (Mobs hardness of 7) makes this material hard on processing equipment. In the Ouachita orogenic belt this unit has been intensely folded, and in most places it is excessively jointed and breaks up into small, angular chunks that very quickly damage the tires of mining equipment.

A recent innovation in aggregate raw material is a quarry in a zone of contact metamorphism (hornfels) associated with the Magnet Cove intrusive complex. A quarry that was operating in the Arkansas Novaculite ran into trouble when a combination of effects caused by a severe storm and changes in regulations on mining practices made continuation of the novaculite pit impractical. On the same property is a tract of Stanley Formation rocks which are adjacent to the predominantly nepheline syenite Magnet Core intrusive complex, and were thus subjected to contact metamorphism that baked the shales into dense, hard, almost chert-like hornfels. Though chert-like in certain aspects, this material is not nearly as hard on equipment as actual chert or novaculite. Only one round of AHTD tests has been run on this material. Loss on the LA Abrasion Test was only 20.4%, but loss on the SS

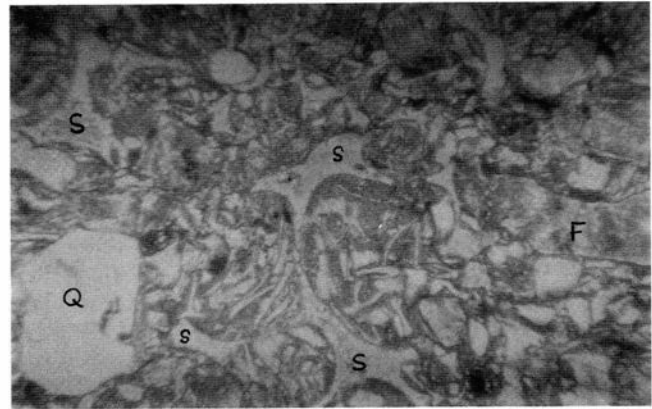

FIGURE 4—Photomicrograph of a Hatton Tuff thin section from a quarry near Hatton, Arkansas. Plane light, field of view 3.8 x 2.4 mm. Sample collected by Henry de Linde. A quartz phenocryst (slightly embayed) is indicated by Q, an alkali feldspar phenocryst by F, and some prominent bubble-wall shards by S.

Soundness Test was 13.6%. However, the SS Soundness Test was redone on a second sample which lost only 3.2%, so the material has been accepted for AHTD jobs. It remains to be seen how consistent this material will be, but it appears to be a good short-term resource. However, the Stanley Formation hornfels will not be a long-standing major resource for crushed stone in the state because the contact-metamorphic aureole around the plutonic complex averages only about 500 m in width (geologic map in Erickson and Blade, 1963). Moreover, only parts of the aureole occur in the Stanley Formation, and some of those areas are already occupied by residential or industrial developments.

### Conclusions

In northern Arkansas, the limestone formations are the most reliable aggregate sources and the preferable choice for future quarry sites. Where limestone is less abundant, as in the far northeastern section of the Ozarks, dolomite will be the best stone available, but some problems with "soundness" will likely be encountered. Research centered on ways how to recognize the best zones in the dolomite, either consistent stratigraphic zones or easily recognized petrographic indicators, would be very helpful to the stone industry in that area. If present trends in environmental protection of Ozark area streams continue, and if alternative local sources of siliceous material cannot be identified, costs for road construction with asphalt concrete in the northern sector of the state will continue to increase because of costs for importation of siliceous aggregate.

In the Arkansas River Valley, the abundant sandstones of that area will continue to be a dependable aggregate source for the future. The reserves are more than adequate for local needs, and this area will probably be an increasingly important source of supplemental siliceous aggregate for northern Arkansas. Also, for locations on suitable transportation courses such as near the Arkansas River, this area will likely continue to supply neighboring southern states.

In the Ouachita region, the syenite plutons along the eastern edge of this province will be a lasting resource for the Little Rock metropolitan area as well as for the Gulf Coast states lacking aggregate resources. Along the southern margin of the Ouachitas, the Jackfork Sandstone, the

Arkansas Novaculite, and the Hatton Tuff are suitable formations for production of aggregate and are well situated for shipping to southern Arkansas, Louisiana, and Texas.

### Acknowledgments

I wish to extend many thanks to Bill Pay, Geologist in Materials and Testing at the AHTD, who has been an invaluable source of information on the crushed-stone industry in the state and on specific problems associated with various rock units. Thanks also to David Lumbert, Geologist with the Research Division of AHTD, for helpful comments and encouragement during the course of this study. Also thanks to William Willis, Senior Geologist with Weyerhaeuser, who suggested this project and who also provided a very helpful review of the manuscript. Gerald Hutchinson of Arkansas Tech kindly provided a timely review of the manuscript. I also wish to thank Bill Williams, former State Geologist, and others on the staff of the Arkansas Geological Commission for encouragement, much useful information, and technical support (maps, AGC publications, etc.).

### References

- Arkansas Highway and Transportation Department, 1993, Standard specifications for highway construction: Arkansas Highway and Transportation Department, Programs and Contracts Division, 794 pp.
- Erickson, R. L., and Blade, L. V., 1963, Geochemistry and petrology of the alkalic igneous complex at Magnet Cove, Arkansas: U.S. Geological Survey, Professional Paper 425, 95 pp.
- Haley, B. R., Glick, E. E., Bush, W. V., Clardy, B. F., Stone, C. G., Woodward, M. V., and Zachry, D. L., 1993, Geologic map of Arkansas: Arkansas Geological Commission and U.S. Geological Survey, scale 1:500,000.
- Merewether, E. A., 1967, Geology of Knoxville quadrangle, Johnson and Pope Counties, Arkansas: Arkansas Geological Commission, Information Circular 20-E, 55 pp.
- Merewether, E. A., and Haley, B. R., 1969, Geology of the Coal Hill, Hartman, and Clarksville quadrangles, Johnson County and vicinity, Arkansas: Arkansas Geological Commission, Information Circular 20-H, 27 pp.
- Miser, H. D., and Purdue, A. H., 1929, Geology of the DeQueen and Caddo Gap quadrangles, Arkansas: U.S. Geological Survey, Bulletin 808, 195 pp.
- Niem, A. R., 1977, Mississippian pyroclastic flow and ash-fall deposits in the deep-marine Ouachita flysch basin, Oklahoma and Arkansas: Geological Society of America Bulletin, v. 88, pp. 49-61.
- Ross, C. S., and Smith, R. L., 1961, Ash-flow tuffs: Their origin, geologic relations, and identification: U.S. Geological Survey, Professional Paper 366, 81 pp.
- Sidder, G. D., and Sims, P. K., 1993, Industrial minerals—Today and tomorrow: The raw materials to build the upper Midwest—Workshop proceedings: Minnesota Geological Survey, Report of Investigations 42, 160 pp.
- Stroud, R. B., Arndt, R. H., Fulkerson, F. B., and Diamond, W. G., 1969, Mineral resources and industries of Arkansas: U.S. Bureau of Mines, Bulletin 645, 418 pp.
- Swanson, D. A., and McGehee, N. A., 1993, Projections of the population of Arkansas, by county, age, gender, and race—1990 to 2010: Arkansas Institute for Economic Advancement, Publication 93-14.

# Industrial minerals south of the Mexican border

Peter W. Harben

*Peter W. Harben Inc., P.O. Box 800, Morris, New York 13808, USA*

**Abstract**—Latin America encompasses more than 30 countries stretching from Mexico in the north to Argentina in the south, and generally includes the Caribbean nations. The region's six largest countries—Brazil, Mexico, Argentina, Colombia, Peru, and Venezuela—account for 75% of the 450 million population. This population is expected to grow to almost 490 million by the year 2000 and 654 million by 2025. This rapid population expansion together with projected increases in per-capita mineral consumption will make Latin America one of the world's fastest growing markets for industrial minerals. The opportunity exists, therefore, for rapid development and expansion of industrial-mineral production in the region as well as for increased international trade.

Latin America has a long mining history and boasts some classic deposits of industrial minerals. Mexico has world-class deposits of fluor spar and celestite (covered in *Mining Opportunities in Mexico* presented at the Forum in Long Beach, California, in 1993 and omitted in this paper); Brazil is one of the few paper-coating-grade kaolin and beryl producers in the world; Chile has unique nitrate (and iodine) deposits and mineral-rich salars with the potential to produce borates, lithium, soda ash, sodium sulfate, salt, magnesium, and more; Argentina is one of only three countries in the world with large-scale borax production; Argentina, Chile, Bolivia, and Peru hold much of the world's ulexite potential outside Turkey; Guyana, and more recently Brazil, set the standards for refractory-grade bauxite. These important operations are discussed in some detail below.

To date, much of this industrial-mineral production has been aimed squarely at the export market, mainly in North America, Europe, and the Pacific Rim. However, there has been an increasing amount of intra-regional trade and plans are in hand to boost this activity through the formation of a free-trade zone stretching from Alaska to Argentina. The 34 members, that is the entire Western Hemisphere minus Cuba, would represent a population of 850 million with a market worth \$13 trillion making it the largest single market in the world.

Beyond the classic deposits mentioned above, the level of production of industrial minerals in Latin America is currently somewhat disappointing. This paper includes tables of industrial-mineral production (1980-1993) by Latin American countries and compares the figures with world totals. These figures demonstrate that the region has to import a great variety of industrial minerals including potash, phosphates, soda ash, talc, and kaolin. The good news, of course, is that this shortfall represents exploration targets. There certainly is potential for increased trade and/or production encouraged by a growing and more sophisticated population, rapidly expanding free-market economics, and increased trade bolstered by reduced tariffs.

## Minerales industriales al sur de la frontera con Mexico

**Resumen**—America Latina abarca más de 30 países desde México en el Norte hasta Argentina en el Sur inclusive las naciones del Caribe, en general. Los seis países más grandes de la región—Brasil, México, Argentina, Colombia, Perú y Venezuela—poseen el 75% de la población total de 450 millones. Se estima que la población de esta región llegará a casi los 490 millones en el año 2000 y a 654 millones en 2025. Este crecimiento rápido de la población y anticipados aumentos en el consumo per cápita de minerales hacen que la expansión del mercado latinoamericano para minerales industriales será una de las más rápidas en el mundo. Por tanto, existe la oportunidad para el desarrollo y expansión acelerados de la producción y el comercio internacional de minerales industriales en la región.

La minería en América Latina viene de hace mucho tiempo y hace alarde de yacimientos clásicos de minerales industriales. México cuenta con depósitos de fluorita y celestita de renombre mundial. Estos yacimientos fueron tratados en el trabajo *Oportunidades de Minería en México* que se presentó en el *Forum* de Long Beach, California, 1993, por lo que se omiten en el trabajo presente. Brasil es uno de los pocos productores en el mundo de berilo y de caolín para revestimiento de papel. Chile posee yacimientos de nitrato y de yodo que no tienen igual, así como salares ricos en minerales explotables, como ser boratos, litio, soda cáustica, sulfato de sodio, sal, magnesio y otros. Argentina es uno de solo tres países productores de borax en gran escala. Argentina, Chile, Bolivia y Perú poseen gran parte de las reservas mundiales de ulexita, fuera de Turquía. Guayana y, más recientemente, Brasil imponen las normas para la bauxita refractaria. Estas operaciones importantes se detallan en el presente trabajo.

Hasta la fecha, mucho de esta producción de minerales industriales ha apuntado plenamente a la exportación, principalmente a América del Norte, Europa y el Borde del Pacífico. Sin embargo, un comercio intra-regional va en aumento y hay planes para incrementar esta actividad mediante la formación de una zona de comercio Libre que abarcaría desde Alaska hasta la Argentina. Los 34 miembros, o sea, todo el hemisferio occidental menos Cuba, representarían una

población de 850 millones y un mercado con valor de 13 trillones de dólares U.S., con lo cual sería el mercado único más grande del mundo.

Fuera de los yacimientos clásicos arriba mencionados el nivel de producción de minerales industriales en América Latina es un tanto desilusionante. En este trabajo se presentan tablas de la producción de minerales industriales por países de América Latina entre 1980 y 1993 y se comparan las cifras con los totales mundiales. Los números demuestran que la región debe importar gran variedad de minerales industriales, inclusive potasa, fosfatos, soda cáustica, talco y caolín. El aspecto positivo es que esta necesidad crea alicientes para la exploración. A la verdad, la situación es promisoría para el comercio y la producción estimulados por una creciente población más desarrollada, regimens de mercado libre en rápida expansión y creciente comercio estimulado por la reducción de tarifas.

### Introduction

Latin America encompasses more than 30 countries stretching from Mexico in the north to Argentina in the south. Generally, Caribbean countries such as Cuba, Jamaica, Haiti, and the Dominican Republic are included. Six countries—Brazil, Mexico, Argentina, Colombia, Peru, and Venezuela—account for 75% of the 450 million population. This population is expected to grow to almost 490 million by the year 2000 and 654 million by 2025 (Fig. 1).

Numerous industrial minerals serve the rapidly growing local markets, and in addition there is an increasing amount of intra-regional trade, particularly within trading blocks such as Mercosur, Caricom, the Andean Pact, and the Central American Common Market (Table 1 for list of members).

The region's strength as a trading block may be fortified still further with the inclusion of the United States and Canada in a trading club—34 countries comprising the Western Hemisphere minus Cuba have begun talks aimed at creating a free-trade zone in the Americas by 2005. If all goes as planned, custom officials will be redundant from Alaska to Argentina in what would be the world's largest single market totaling \$13 trillion, with a

population of 850 million. Negotiations started in May 1995 for Chile to join NAFTA. However, the simple concept of dropping the "N" from the acronym resulted in a near diplomatic *faux pas* since "AFTA" in Portuguese means an "open sore in the mouth," an anathema for politicians.

Latin America is also an important supplier of a variety of industrial minerals to world markets (Table 2; Fig. 2). Mexico is a prominent supplier of fluorspar, sulfur, gypsum, salt, and celestite (covered in *Mining Opportunities in Mexico* presented at the Forum in Long Beach, CA, in 1993); Brazil is one of the few large-scale producers of coating-grade kaolin and of beryl in the world; Chile has unique nitrate (and iodine) deposits and mineral-rich salars containing lithium soda ash, sodium sulfate, salt, magnesium, and more; Argentina, Bolivia, and Peru share a borate-rich region with Chile; and Guyana sets the standard for refractory-grade bauxite. Virtually all this production is geared to serve the export market, mainly North America, Europe, and the Pacific Rim.

The following sections discuss five of the region's most important industrial minerals—bauxite, kaolin, borates, nitrates, and iodine.

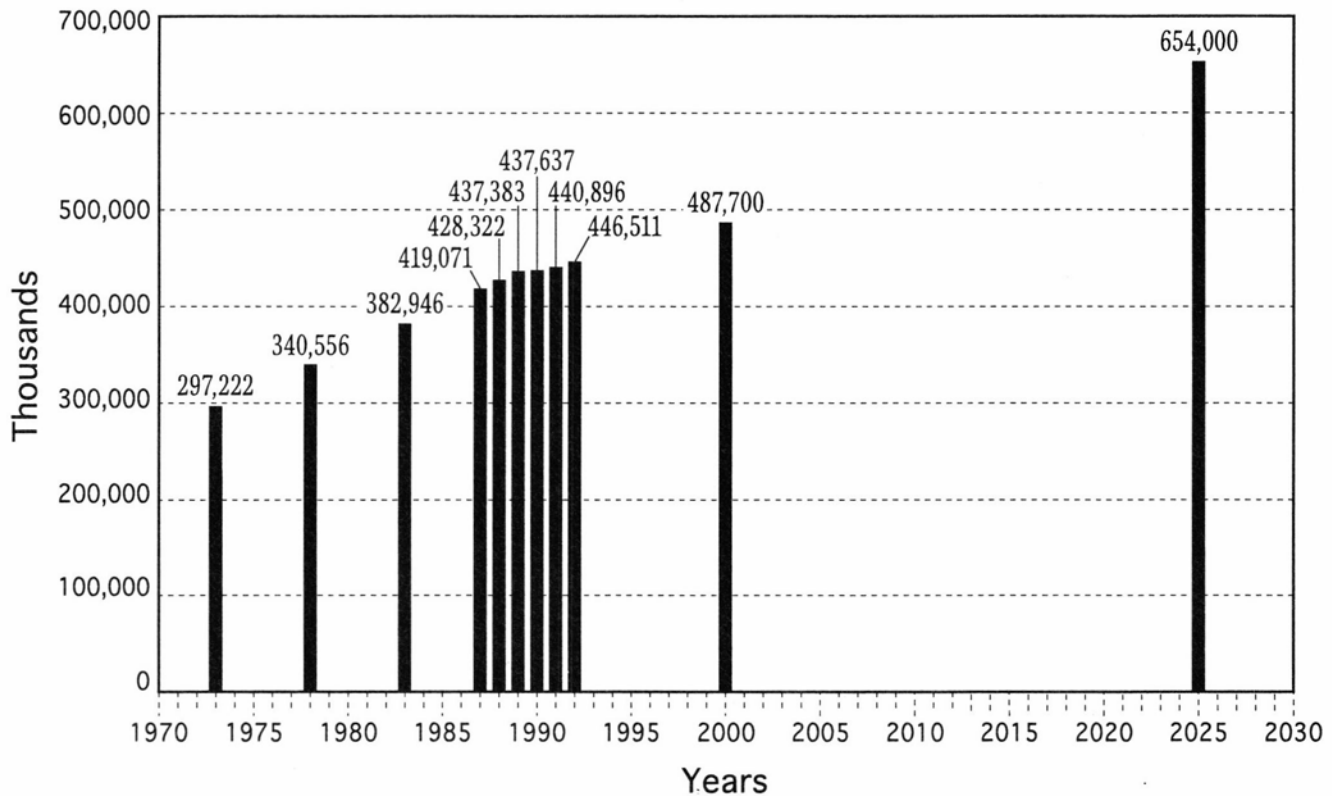

FIGURE 1—Population growth in Latin America with estimated values in 2000 and 2025.

TABLE 1—Trade groups in the Americas.

North American Free Trade Agreement (NAFTA)	MERCOSUR	Andean Pact	Central American Common Market (CACM)	CARICOM
Canada	Argentina	Bolivia	Costa Rica	Antigua/Barbados
Mexico	Brazil	Colombia	El Salvador	Bahamas
United States	Paraguay	Ecuador	Guatemala	Barbados
	Uruguay	Peru	Honduras	Belize
		Venezuela	Nicaragua	Dominica
				Grenada
				Guyana
				Jamaica
				Montserrat
				St. Kitts/Nevis
				St. Lucia
				St. Vincent and The Grenadines
				Trinidad/Tobago
<i>Market Size</i>				
<b>380,000,000</b>	<b>190,000,000</b>	<b>93,000,000</b>	<b>28,000,000</b>	<b>5,500,000</b>

TABLE 2—The 1993 production of industrial minerals in Latin America. Data in metric tons unless otherwise noted.

	Production	Percent of world production
Celestite	71,028	49
Iodine	5,550	33
Bauxite ('000)	29,104	28
Silica sand	16,566,921	16
Lime ('000)	14,794	14
Salt ('000)	20,300	14
Beryl	885	13
Sodium sulfate	620,000	13
Fluorspar	471,000	12
Boron minerals (of mineral and/or compound)	243,000	11
Graphite	567,390	11
Manganese ('000, gross weight)	2,313	11
Gypsum ('000)	8,926	10
Asbestos ('000)	246,000	9
Feldspar	522,091	9
Kaolin	2,050,332	8
Pyrophyllite	163,000	8
Lithium	12,530	8
Diatomite	109,000	8
Pumice	821,780	8
Monazite	1,400	7
Cement ('000)	89,987	7
Barite ('000)	313,300	6
Mica	12,009	6
Vermiculite	29,500	6
Talc	350,855	6
Nitrogen (ammonia) ('000 contained nitrogen)	5,070	6
Chromite (gross weight)	480,000	5
Sulfur, all forms ('000)	2,732,000	5
Iron oxide	286,772	5
Bentonite ('000)	375,039	5
Phosphate rock (gross weight)	3,687,000	3
Magnesite	268,900	3
Wollastonite	13,000	3
Perlite	37,222	2
Soda ash	711,000	2
Industrial diamonds ('000 carats)	55,703	2
Titanium minerals—ilmenite	70,000	2
Zircon	19,000	2
Potash (K <sub>2</sub> O)	228,000	1
Sillimanite mineral	600	0.2
Titanium—rutile	1,100	0.2

Latin America contributed about 28% of the world's bauxite production in 1993, largely from Jamaica (11 million mt/yr), Brazil (9 million mt/yr), Surinam, Guyana, and Venezuela (3 million mt/yr each). Although not the largest producer, Guyana is particularly intriguing since much of its output goes into non-metallurgical uses, in particular refractories and abrasives, with special chemical requirements as outlined in Table 3.

The commercial deposits of bauxite in Guyana occur in a belt 10-12 km wide and 125 km long, roughly parallel to the Atlantic coast (Fig. 3). Deposits in the bauxite belt, tend to occur in groups and are made up of gibbsite and minor boehmite, with kaolinite filling pockets in the deposits or occurring as dikes or irregular veinlets. Siderite is the most common iron mineral, and there are lesser amounts of goethite, pyrite, and hematite. Around 70% of the known bauxite reserves in Guyana have sufficiently low iron and silica to be classified as being chemical, abrasive, or refractory grade. Higher-iron bauxite is regarded as metallurgical grade. Bauxite from Guyana typically has the following composition:

Al <sub>2</sub> O <sub>3</sub>	55-60%
SiO <sub>2</sub>	1-10%*
Fe <sub>2</sub> O <sub>3</sub>	0.8-5%
TiO <sub>2</sub>	2-5%
LOI	30-32%

\* 10% is the refractory-grade cut off

### Producers

Since nationalization in 1971, the bauxite operations in Guyana have been run by the state-owned Bauxite Industry Development Company (BIDCO). However, plans are in hand to privatize the operations. The main refractory-grade bauxite operations are located around Linden on the Demerara River about 105 km south of the capital Georgetown (smaller operations are some 95 km south of Linden and serve the Berbice plant on the Berbice River and the processing plant at Everton near New Amsterdam. Because of their virtually unique nature, these deposits were developed and operated by Alcan in parallel with that company's commercial development of high-alumina refractories and chemicals.

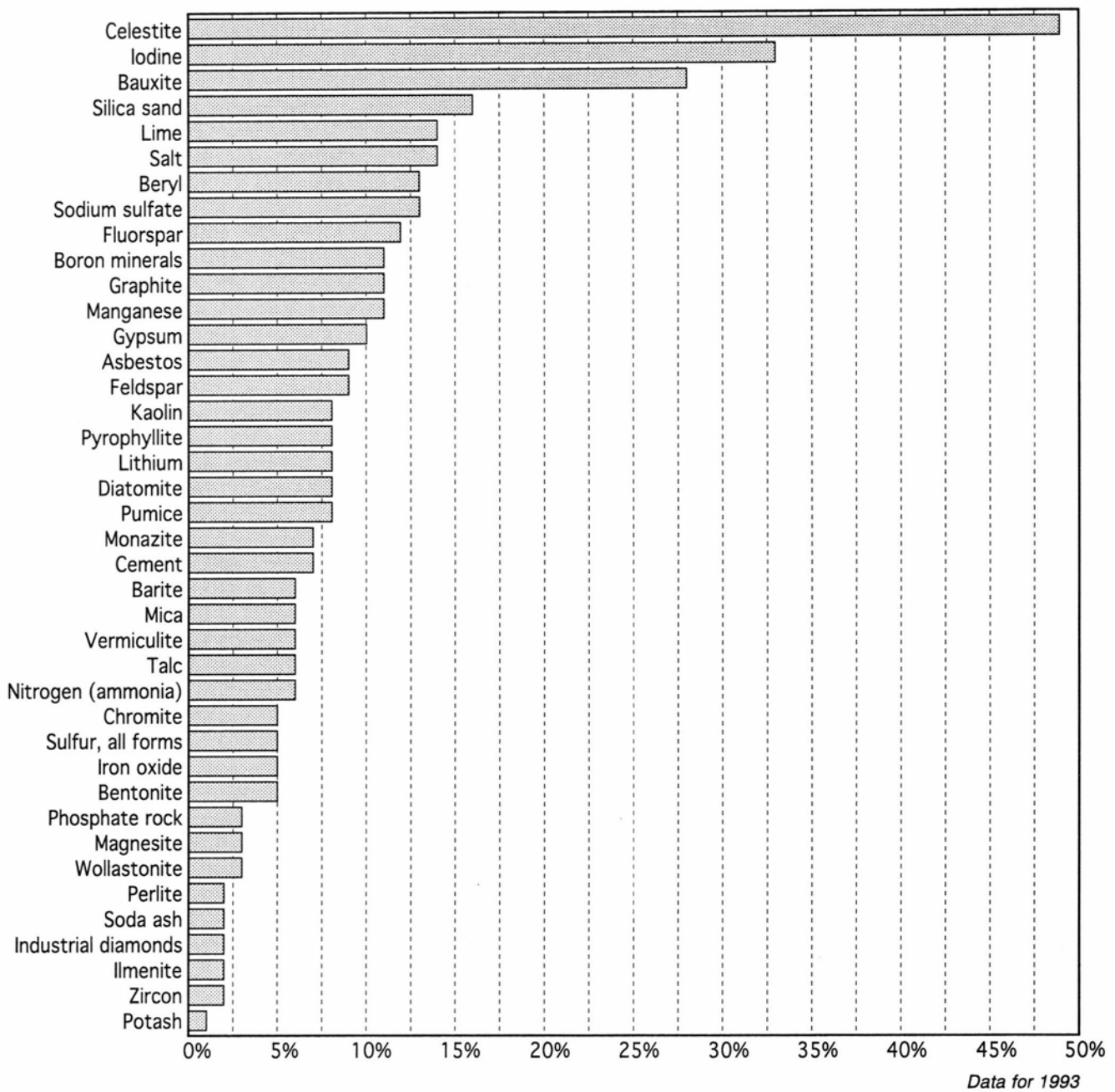

FIGURE 2—Industrial minerals in Latin America as a percentage of world total.

The thick and varied overburden requires a fairly complex mining plan which includes excavating the top sand with bucket-wheel excavators, removing the clay below using draglines, and then removing the bottom section of overburden by scrappers to expose approximately 10 m of bauxite ore. Waste material is

TABLE 3—Specifications for bauxite by end use.

	Metallurgical	Chemical	Cement	Refractory (calcined)	Abrasive (calcined)
Al <sub>2</sub> O <sub>3</sub>	50–55% min.	55%	45–55% min.	84.50%	80–88%
SiO <sub>2</sub>	0–15%	5–18% max.	6% max.	7.50%	4–8%
Fe <sub>2</sub> O <sub>3</sub>	5–30% max.	2%	20–30% max.	2.50%	2–5%
TiO <sub>2</sub>	0–6%	0–6%	3% max.	4%	2–5%

sent by conveyor belt to the adjoining mined-out area. Ore from several mines is trucked to a central stockpile and then delivered to the plant by rail. At the plant +10 mesh material (which constitutes about 40% of the ore as mined) is fed to the calciners; the balance is either used for dried bauxite products or is discarded as waste. Calcining creates still more losses, since 1.85 mt of ore yields 1 mt of calcined bauxite. Overall, 100 mt of raw bauxite yield 20 mt of Refractory A-grade Super Calcined Bauxite (RASC). This has become the industry standard with a typical Al<sub>2</sub>O<sub>3</sub> content of 88.30% and a guaranteed minimum of 86.50%. The typical bulk specific gravity is 3.13.

Exports of bauxite are largely to the United States, Europe, and to a lesser extent Japan (Fig. 4). Production in Guyana has fallen over the past 15 years, and production of calcined refractory-grade bauxite in particular has

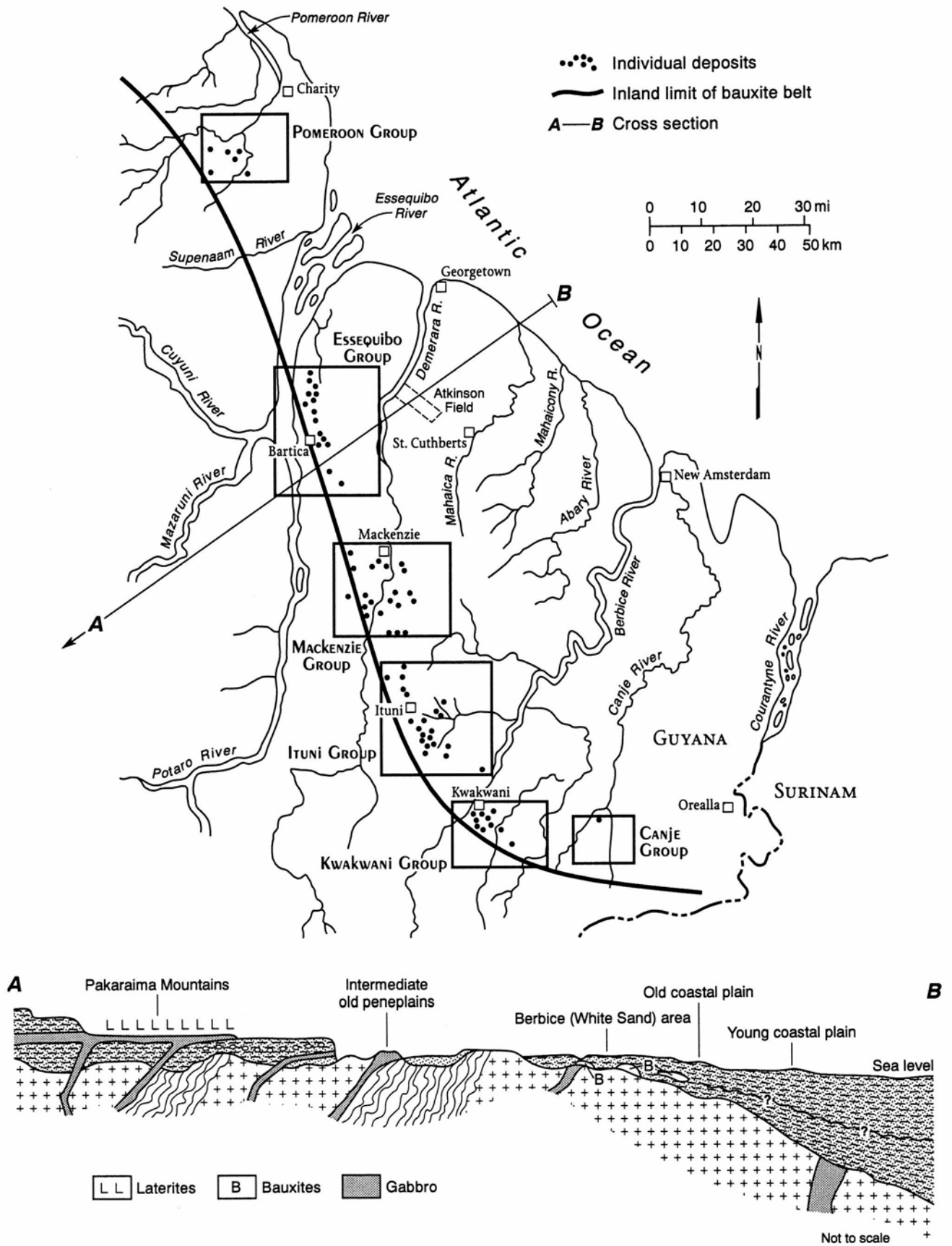

FIGURE 3—The main bauxite areas of the Guiana Shield. After Harben and Bates (1990); adapted from Aleva (1982) and Bleackley (1964).



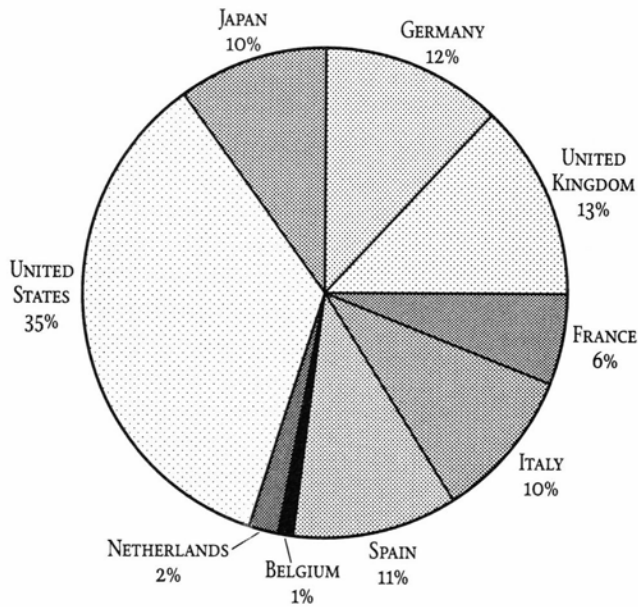

FIGURE 4—Guyanan exports of calcined bauxite from.

fallen from over 500,000 mt/yr at the beginning of the 1980s to less than 300,000 mt today; exports to the United States have fallen from 200,000 to 50,000 mt/yr over the same period. This decline is due to a combination of factors including competition from China and Brazil, high mining and production (oil for calcining) costs, irregularities in the quantity and quality of production, a decline in the size of the calcined-bauxite market, and domestic disorganization combined with industrial disputes and a lack of marketing expertise (Fig. 5).

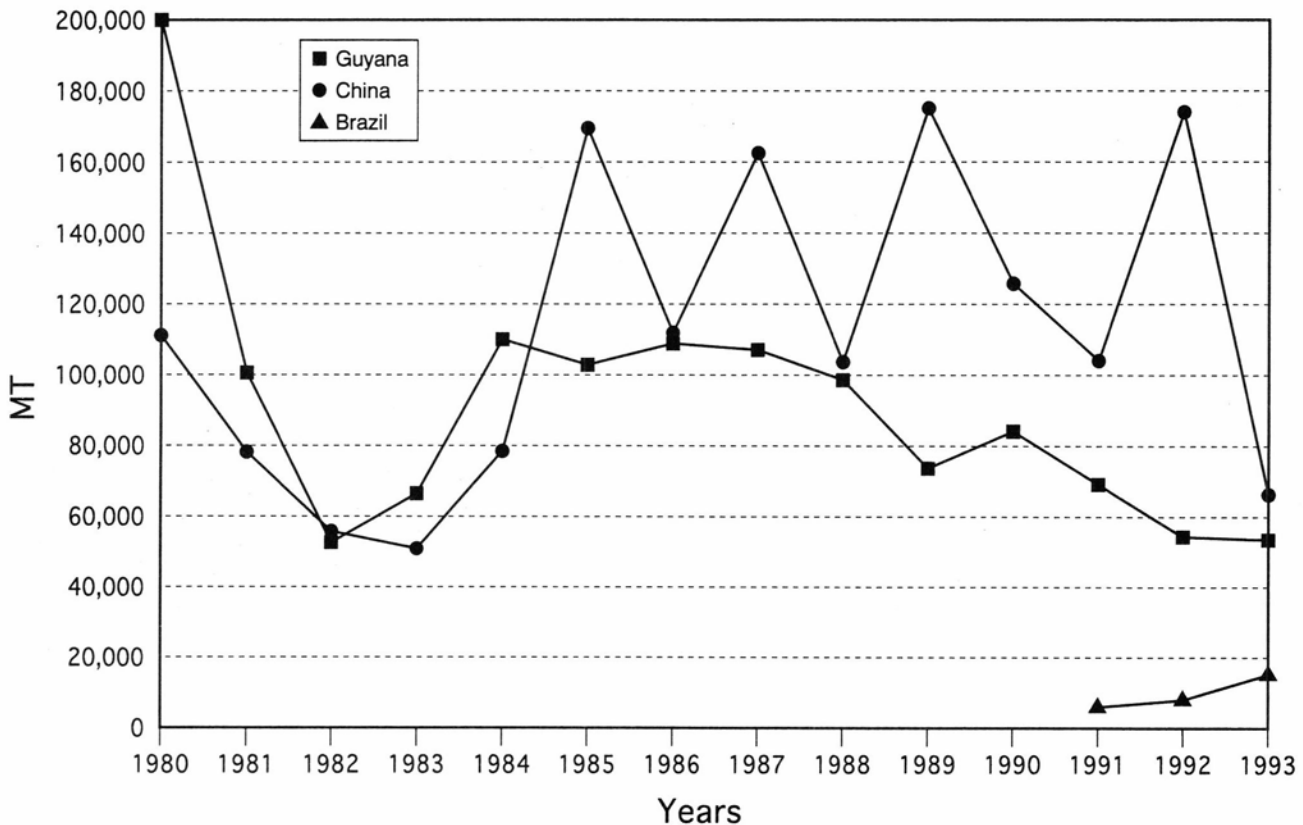

FIGURE 5—United States imports of calcined bauxite.

### Kaolin

Worldwide kaolin-production capacity just over 27 mt/yr is spread among more than 50 countries. The bulk is relatively low-cost unprocessed "common clay" used in lightweight aggregate, cement, brick, civil engineering and sealing, refractories, etc. In contrast, refined or processed grades of kaolin used as a feedstock for ceramics and as a white pigment in paint, plastics, rubber, paper, etc., are restricted to the United States (capacity of 9 million mt/yr), United Kingdom (3.7 million mt/yr), Australia (230,000 mt/yr), and Brazil (820,000 mt/yr) (Fig. 6). This refined kaolin (see chemistry and specifications in Tables 4 and 5) is a higher-priced, more sophisticated product serving an extremely wide geographic area through a modern long-distance transportation system.

Most Brazilian kaolin deposits were derived from pegmatites and similar rocks through intense weathering and then transported as sediment to their present location. These secondary kaolin deposits form part of the Pliocene Barreiras Series, a 700 m sequence of unconsolidated sandstone, mixed sand-clay, and kaolinitic clay. The upper part—the Belterra clays—contains the commercial clay beds that are 25-32 m thick and extend over an area of several tens of square kilometers. The clay is very fine (75% <2µm) and very similar to the hard, fine Tertiary clays of Georgia in the United States.

### Producers

Some 25 years ago a major pulp facility and adjacent kaolin plant were built on the jari River just north of the Amazon River delta in the State of Para, Brazil. The Filipe Mine, about 350 km west of Belem, is now owned by Caulim de Amazonia (CADAM), which in turn is owned by CAEMI, a major Brazilian iron ore and ferroalloys producer.

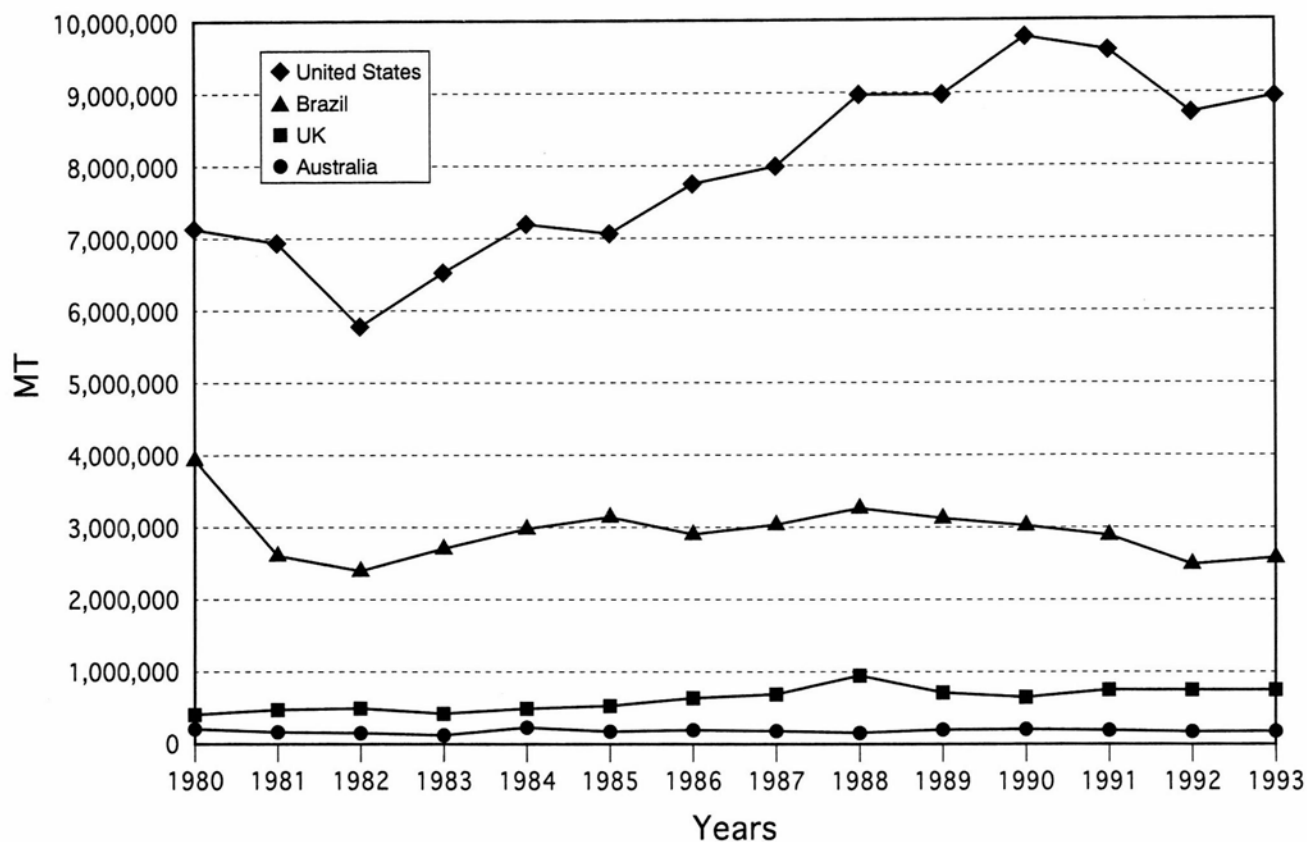

FIGURE 6—Production of refined kaolin production (mt).

The open-pit mine is located on the east bank of the Jari River about 100 km north of its junction with the Amazon River. Overburden stripping and clay mining employ self-loading scraper pans in a pit with 6 m high benches. Six benches are currently working the 32 m of

TABLE 4—Chemistry of commercial clays. After Pickering and Murray (1994).

	Kaolin (coarse coating) Georgia, USA	Kaolin (fine coating) Georgia, USA	Kaolin (fine coating) Brazil	Kaolin (coarse coating) Cornwall, UK
SiO <sub>2</sub>	45.2	45.0	46.0	47.2
Al <sub>2</sub> O <sub>3</sub>	39.2	38.0	37.0	37.6
Fe <sub>2</sub> O <sub>3</sub>	0.58	1.0	1.8	0.68
TiO <sub>2</sub>	0.53	1.6	0.98	0.04
MgO	0.08	0.09	0.07	0.2
CaO	0.06	0.06	0.02	0.08
Na <sub>2</sub> O	0.03	0.29	0.08	0.08
K <sub>2</sub> O	0.02	0.13	0.0	1.39
H <sub>2</sub> O	13.3	14.0	14.3	12.7

kaolin under about 11 m of overburden. Clay is blunged and dewatered in a stockyard in the mining area and transported by pipeline under the Jari River to the plant at Muguba on the west bank. Processing includes centrifuging to 97% <2µm, reduction leaching, filtration, and extrusion and apron drying. The clay is loaded in bulk directly onto large ocean-going vessels.

CADAM produces a very fine particle-size glossing kaolin known as *Amazon 88*, of excellent viscosity but only fair brightness and color (its main function is to improve the gloss of carbonate paper and to blend with coarser kaolin to improve their viscosity). The company introduced the brighter *Amazon 90* grade to the market in 1994. This grade, mainly for export to Europe and Japan, is produced by purification in cryogenic magnetic separators bought from Carpcos SMS Ltd. of the UK. The company is in the midst of a 5 year, \$43 million investment program designed to increase the production capacity of coating-grade kaolin to 750,000 mt/yr by 1995 and to establish an efficient worldwide distribution network. Kaolin exports from Brazil have increased from about 250,000 mt in 1990 to more than 400,000 mt in 1993. The most consistent growth has been in sales to Europe,

TABLE 5—Typical specifications for commercial paper-grade coating ka

	#2 High brightness	#1 High brightness	#1 Fine high brightness
TAPPI brightness, %	89.5–90.5	89.5–91.0	90.0–92.0
Particle size, %<2µm	80–84	90–92	96–100
Surface area, m <sup>2</sup> /g	12	13	22
325 mesh residue, max. %	0.01	0.01	0.01
Moisture, max. %	1	1	1
pH (28% solids)	6.0–7.5	6.0–7.6	6.0–7.7
Brookfield, 20 rpm, cps	350	350	350

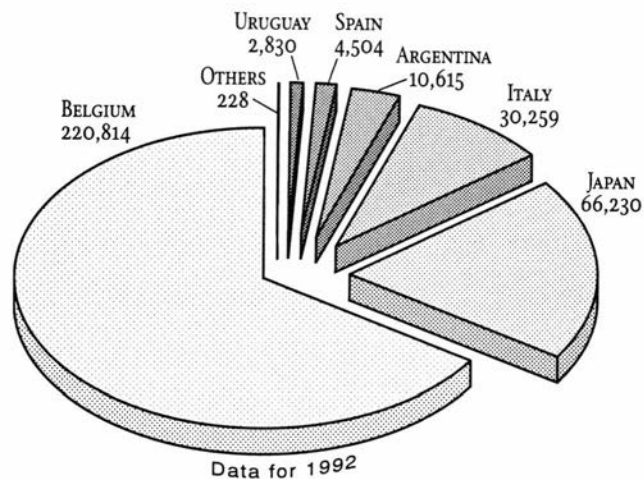

FIGURE 7—Brazilian exports of kaolin (mt).

which in 1993 accounted for 70% of exports. The bulk of the balance goes to Japan.

### Potential producers

Plans to develop extensive coarse-crystal (60% <2 $\mu$ m) kaolin deposits in northern Brazil are centered along the Capim River, south of the Jari River in Para State. In addition to being coarse-grained, the clay is soft and has a smooth conchoidal fracture, low Brookfield and Hercules viscosities, a high percentage of stack-like crystals packed face-to-edge, low iron and titanium content, and a leached GE brightness of 89.

There are several major kaolin projects in Brazil at various stages of development. These kaolin ventures have ambitious plans to penetrate world markets in the second half of the 1990s, but the remoteness of the area, lack of infrastructure, and poor state of Brazilian economy may prove difficult hurdles.

Rio Capim Quimica (RCQ), a joint venture between CADAM and Companhia Vale do Rio Doce (CVRD), is developing a paper-coating-grade kaolin mine with an initial capacity of 300,000 mt/yr near the town of Ipixuna. The capital investment is expected to be \$120 million for the first stage, with an additional \$130 million if the planned expansion to 1 million mt/yr materializes. However, the project has experienced delays because of environmental objections over a proposed 180 km long pipeline designed to carry kaolin slurry from the mine to the port of Barcarena near Belem at the mouth of the Para River.

A second project involves Rio Capim Caulim (RCC), a subsidiary of Mendes Junior, a Minas Gerais-based industrial group which will develop a kaolin deposit in Para State. Initial production of paper-coating-grade kaolin is scheduled for 1997 at a rate of 500,000 mt/yr, which could be increased to 1 million mt/yr as the market allows. About 90% will be exported, mainly in powder form, although slurry will be made where required using distributor's facilities. The total capital investment will be approximately \$120 million, to be shared between Mendes and the foreign shareholders. RCC is joining with Amberger Kaolinwerke GmbH (AKW) of Germany and other distributors to "ensure a market for its product and to share the project risks." The agreement allows AKW to take a 20% participation in RCC, and Euroclay, a AKW subsidiary, will become the distributor in Europe and Scandinavia. Additional 20% of RCC

TABLE 6—Production capacity of boron minerals in metric tons of B<sub>2</sub>O<sub>3</sub>. Adapted from Lyday (1991).

United States	735,000
Argentina	28,000
Bolivia	24,000
Chile	47,000
Peru	5,000
Turkey	560,000
Former USSR	41,000
China	5,000
<b>TOTAL</b>	<b>1,445,000</b>

shares have been set aside for the North American and Asian distributors (as yet unnamed).

Companhia de Pesquisa e Recursos Minerais (CPRM), the Brazilian geological survey, intends to privatize a kaolin deposit also in the Rio Capim area. Discovered in 1971, the deposit has 211 million mt of measured surface reserve of coating-grade kaolin. In 1989 Engelhard Corporation agreed to buy the rights to the deposit for \$26 million and commit to funding a 500,000 mt/yr mine and processing facility. However, irregularities and litigation nullified the sale and transfer process, forcing Engelhard to withdraw its offer. The deposit is once again up for auction.

On a smaller scale, Empresa de Caolim SA, a subsidiary of Industrias Klabin SA, is investing \$7 million in a kaolin operation at Bela Vista in Minas Gerais State. This will produce about 85,000 mt/yr of filler and ceramic-grade kaolin.

### Markets served

By far the bulk of the kaolin exported from Brazil is paper grade (*Amazon 88* and more recently *Amazon 90*). The main export markets are Belgium (as a gateway to Europe), Japan, Italy, Argentina, and Uruguay (Fig. 7).

### Borates

Commercial deposits of borates are extremely rare and their supply is geographically limited. The United States (based on borax, Na<sub>2</sub>B<sub>4</sub>O<sub>7</sub>·10H<sub>2</sub>O) and Turkey (based on borax, colemanite, Ca<sub>2</sub>B<sub>4</sub>O<sub>11</sub>·5H<sub>2</sub>O, and ulexite, NaCaB<sub>5</sub>O<sub>9</sub>·8H<sub>2</sub>O) control 70% of the world's known reserves and traditionally have dominated production. In recent years, however, this neat pattern has been disrupted by the emergence of Russia (based on datolite, CaBSiO<sub>4</sub>(OH)) as a supplier and by increased production in Latin America. Production capacities are provided in Table 7 and Figure 8.

TABLE 7—Specifications of borates produced in Chile. Values in wt.% unless noted otherwise. After Quiborax.

	Synthetic colemanite	Washed ulexite	Boric acid-technical	Boric acid-glass grade
B <sub>2</sub> O <sub>3</sub>	42	39.82	—	—
H <sub>3</sub> BO <sub>3</sub>	—	69.99	99.5	99.9
CaO	33	12.44	—	—
Na <sub>2</sub> O	—	7.14	—	—
Na <sub>2</sub> O-K <sub>2</sub> O	0.4 max	—	—	—
Al <sub>2</sub> O <sub>3</sub>	—	0.81	—	—
SiO <sub>2</sub>	3.0 max	—	—	—
As <sub>2</sub> O <sub>3</sub> (ppm)	150 max	100	—	—
Cl (ppm)	—	250	50	—
SO <sub>3</sub> (ppm)	—	600	150	—
Fe <sub>2</sub> O <sub>3</sub>	0.10 max	0.18	10 ppm	10 ppm

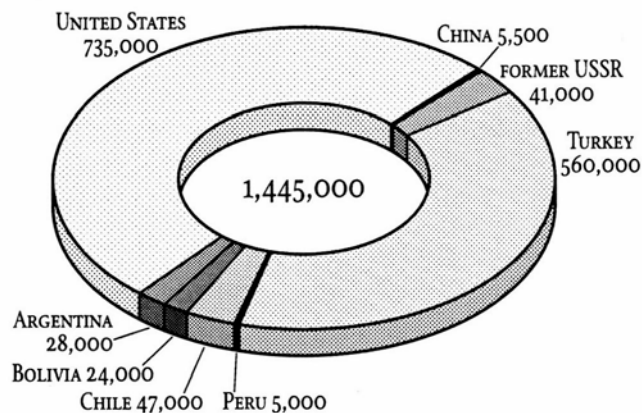

FIGURE 8—World production capacity of boron minerals (mt B<sub>2</sub>O<sub>3</sub>). After Lyday (1991).

Numerous borate deposits have been identified in the Cenozoic volcanogenic-sedimentary rocks in a 880 km long stretch of the Andes along the common borders of Argentina, Bolivia, Chile, and Peru. These are aprons, cones, or beds of ulexite and borax. Local tectonic and volcanic activity provided the materials, and the concentrating effect of the arid climate at altitudes of 3,000-4,000 m combined to form the deposits. Most have undergone relatively little deformation or diagenesis since their emplacement. For the most part, borate production in Latin America is based on ulexite along with one large deposit of borax.

### Producers

The leading borate producer in the region is Borax Argentina S.A., a subsidiary of US Borax Inc.; it operates the Tincaluya borax mine in Salar del Hombre Muerto, Salta Province, Argentina, which exploits a lenticular body of borax some 30 m thick and 100 m wide. The borax is intercalated with sandstone, claystone, tuff, evaporite, limestone, and conglomerate of the Sijes Formation, which rests on a thick halite sequence and is overlain by 50 m of sandstone, siltstone, and tuff. The age is uncertain. As mined, the borax ore is washed at the mine site and trucked to the processing plant at Campo Quijana near Salta City that has the capacity to produce 41,000 mt/yr equivalent of borax decahydrate (ten mole) as either borax decahydrate, borax pentahydrate, and/or anhydrous borax. Near Sijes to the north, up to 5,000 mt/yr of hydroboracite are produced at the Monte Amirillo Mine and 1,000 mt/yr of colemanite at the Esperanza Mine. Still farther north in Jujuy State is the Salar de Cauchari where Boroquimica's Porvenir Mine produces small quantities of ulexite. There are numerous small intermittent producers of ulexite in Argentina, many of which convert the mineral to boric acid.

Over the border in Chile, Quimica e Industrial del Borax Ltda. (Quiborax) produces around 200,000 mt/yr of ulexite at the Salar de Surire, which is used to feed a plant with the capacity to produce 36,000 mt/yr of boric acid, 25,000-30,000 mt/yr of 38-40% B<sub>2</sub>O<sub>3</sub> washed ulexite, and 24,000 mt/yr of 42%B<sub>2</sub>O<sub>3</sub> synthetic colemanite. Specifications of the main products are given in Table 7. At the time of writing (March 1995), negotiations for the acquisition of Quiborax by North American Chemical Corp. (NACC) were reportedly taking place.

Other smaller producers in Chile include Occidental Chemicals (Oxychem) (4,000 mt/yr boric-acid plant at

Talcahuano near Concepcion, 500 km south of Santiago), Minero del Boro (2,500 mt/yr of boric acid at Alto Hospicio), and Minera Ascotán (1,000 mt/yr of ulexite at Salar de Ascotán). Sociedad Minera Salar de Atacama (Minsal), a partnership of Amax, Corfo, and Molibdenos y Minerales, is a project designed to produce 500,000 mt/yr of KCl, 15,000 mt/yr of lithium carbonate, and 28,000 mt/yr of boric acid. However, Amax has been less than enthusiastic, and the project is on hold. There are several projects designed to develop the large borate resources of Chile.

To the north in Bolivia, Tierra S.A. mines ulexite ore from Salar de Capina and Salar Uyuni. The dried and calcined ore is used to feed a plant capable of producing three ulexite grades-30-32%, 35%, and 40% B<sub>2</sub>O<sub>3</sub> as well as boric acid. The mine and plant are high in the Andes (over 4,000 m elevation), and the company has severe financial problems. Production of ulexite in Peru, confined to the Laguna Salinas in the south, is dominated by an Italian company called Bittosi. However, it appears that low prices have forced the operation to close. Borate production since 1980 in Argentina and Chile is summarized in Figure 9.

### Markets served

The main use of borates is the glass industry where B<sub>2</sub>O<sub>3</sub> is a critical ingredient in the manufacture of fiber, borosilicate, container, and lead-crystal glass. The two important commercial types of fiberglass are textile-grade fiberglass (TGFG) and insulation-grade fiberglass (IGFG). More than half of the TGFG is used in glass-reinforced plastics (GRP) which in turn are formed into boat hulls, shower stalls, fishing rods, and the like. The second largest end-use category is in roofing shingles, carpet backing, and tires. Minor uses include electrical applications such as a reinforcing agent in transformer and electrical components and printed circuit boards, and household uses such as fabrics and appliances. Since the sodium content of textile-grade fiberglass needs to be kept to a minimum, colemanite and/or boric acid are the main sources of B<sub>2</sub>O<sub>3</sub>; there is no such restriction for insulation-grade fiberglass that uses mainly borax pentahydrate.

Except for Brazil and perhaps Mexico, the markets for borates within Latin America are quite modest. However, the limited number of large-scale borate suppliers promotes active international trade with significant tonnages being shipped to North American, European, and Pacific Rim markets. Exports of boric acid from Chile are mainly to the United States, Belgium, Japan, and the United Kingdom; ulexite is shipped to the United States, South Africa, Philippines, and Korea; and small amounts of refined borax go to Argentina, Peru, and Bolivia. Synthetic colemanite, which is no longer produced, was largely aimed at the Pacific Rim market, in particular Japan (Figs. 10, 11).

### Nitrates and iodine

Although eclipsed somewhat by synthetic sources for almost a century, natural nitrates are still produced commercially in Chile's Atacama Desert, specifically in the northernmost provinces of Tarapaca and Antofagasta. These deposits also yield commercial quantities of iodine.

Until about 1830, deposits of guano (bird and bat excreta) or the waste from slaughter houses, fish processing plants, and the like supplied the world's need for nitrates. Then Chile began supplying commercial quan-

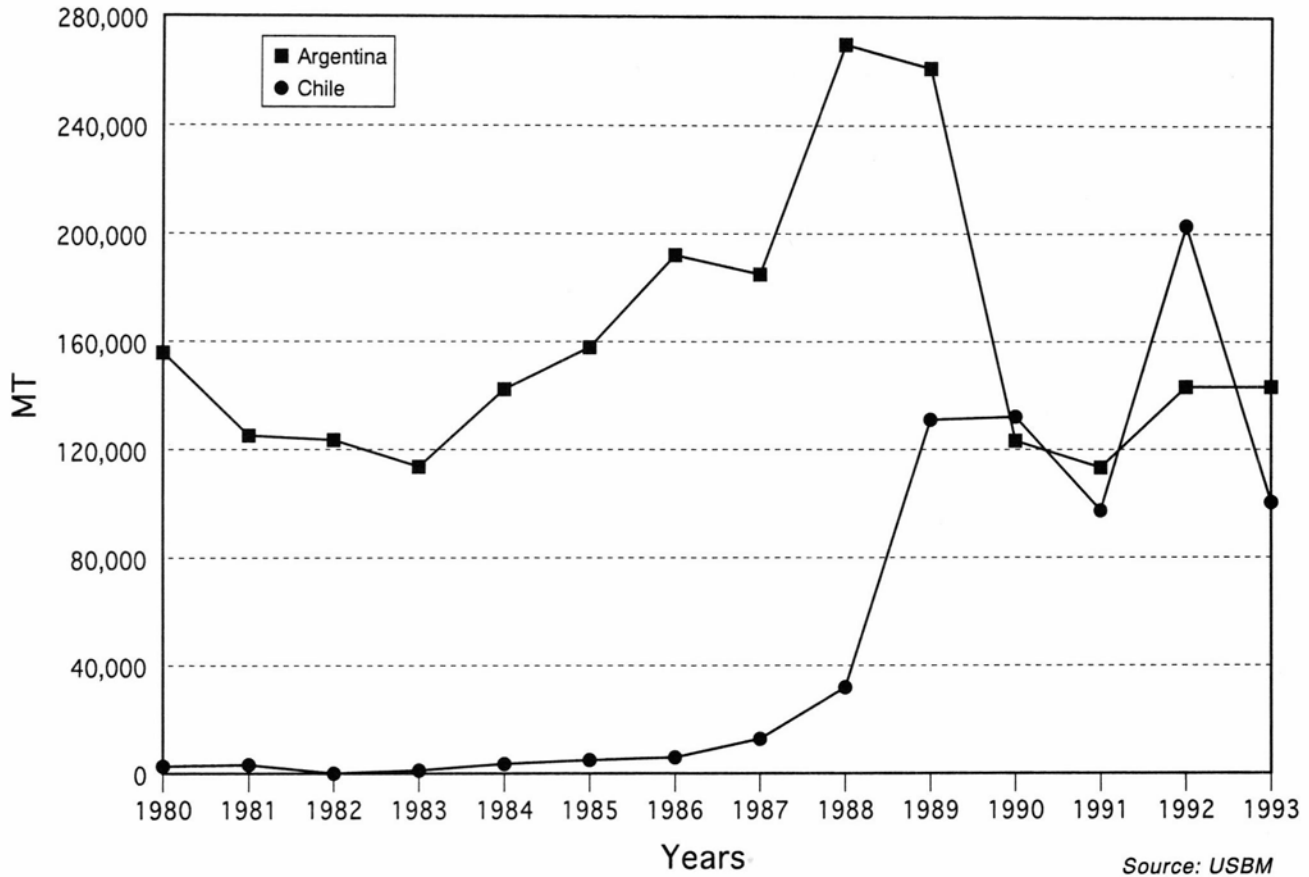

FIGURE 9—Latin American boron mineral production (mt of mineral and/or compound).

tities from its natural deposits in a 7 km wide belt extending for almost 150 km along the eastern side of the Coastal Range, a chain of relatively low mountains separated from the high Andes by a trough. The general area

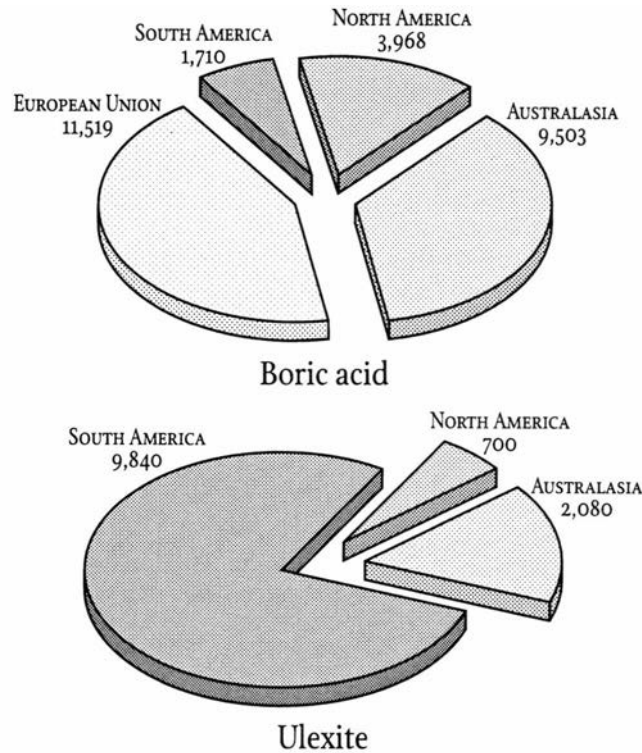

FIGURE 10—Chilean exports of borates (mt).

contains nitrate-rich soils, surfaces encrusted with nitrate-bearing soils, saline-cemented regolith, closed basins containing clay playas, and the commercial deposits themselves.

Commercial concentrations occur on or in rock types ranging from granite to limestone and shale, and there is little obvious correlation between the deposit and rock type. The caliche ore is part of a sequence of layers from coba at the base through caliche and costra to the chuca overburden, each with different physical and chemical characteristics. The caliche can be of the alluvial type with saline minerals cementing the regolith, or of the bedrock type with these minerals forming impregnations, veins, and irregular masses in porous or fractured bedrock. The deposits also contain relatively high concentrations of iodate.

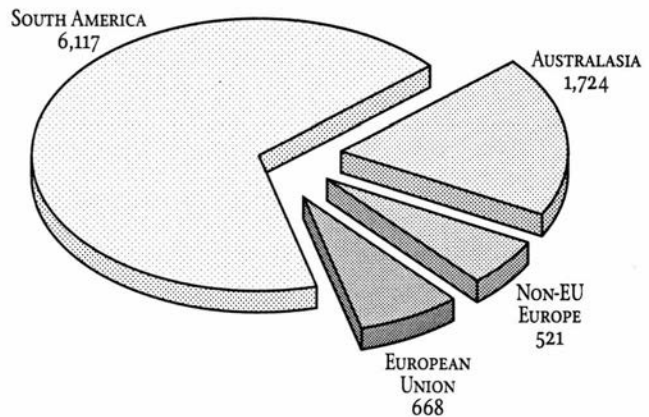

FIGURE 11—Argentinian exports of boric acid (mt).

These nitrate deposits are highly unusual as is the local climate. With an average annual rainfall of less than 0.1 cm and as much as 20 years between rain showers, this part of the Atacama Desert is among the driest regions in the world. More important, these conditions have prevailed since about the middle of the Miocene, which has allowed the gradual build-up of substantial quantities of saline materials.

**Producers**

The world's largest nitrate producer is SQM Nitratos, part of Sociedad Quimica y Minera de Chile SA (Soquimich). Caliche mined by dragline and power shovels in numerous open pits or "rajos" feeds process plants at Maria Elena and Pedro de Valdivia, both inland from the port of Tocopilla in Antofagasta province. The ore has a composition ranging 7-10% NaNO<sub>3</sub>, 4-10% NaCl, 10-30% Na<sub>2</sub>SO<sub>4</sub>, 2-7% Mg, Ca, K, Br, and I, 1-2% H<sub>2</sub>O, and 41-76% gangue. Ore is concentrated by a variation of the Guggenheim process. First used in the early 1920s, this involves counter-current leaching, with a saturated solution of sodium chloride and sulfate containing 320-340 g/l of NaNO<sub>3</sub> at 40-45°C (104-113°F). After about four days the solution contains 440-480 g/l of nitrates that crystallize out on cooling, leaving the original solution to be recycled. This process allows ore containing 10% nitrate or less to be mined commercially.

Nitrate production has declined from a peak in 1928, when 75 mines or "officinas" employed 45,000 men and produced 3.2 million mt/yr, to the current levels whereby SQM has the capacity to produce 900,000-1,000,000 mt/yr of different grades of nitrates, mainly 600,000 mt/yr of sodium nitrate and 400,000 mt/yr of potassium nitrate. Specifications are given in Table 8.

Production by Soquimich at the Pedro de Valdivia and Maria Elena plants is reported to have a capacity of between 242 and 250 mt/yr. Potential iodine reserves are estimated at 149,787 mt of economically recoverable iodine in ore surrounding the existing mining operations, and 199,716 mt more in overburden and waste dumps close to the plants.

There have been rumors that the Canadian firms Kap Resources and British Columbia Ltd. plan to develop Los Yombes and Yolanda salt flats near Taltal Region II. According to the rumors the deposits contain 122 million mt of iodine and nitrate with an average yield of 450 grams of iodine and 13.4% content of sodium nitrate. The investment is \$45 million for a project producing 1,000 mt/yr of iodine and 300,000 mt/yr of sodium nitrate.

**Markets served**

Nitrogen is one of the three primary plant nutrients, along with potassium and phosphorus, and is therefore an important fertilizer. Natural sodium nitrate may be used as a single nutrient or mixed with other nutrients into a multiple-nutrient fertilizer. Non-fertilizer applications for nitrate compounds include water treatment, food preservatives, and alkaline conditioning. Iodine is used in a variety of industries either in the form of resublimed iodine, organic compounds, or most commonly as inorganic compounds such as sodium, potassium, calcium, and ammonium iodide, and calcium and ammonium iodate. Little recognized but very important and necessary everyday use of iodine is as a dietary supplement to prevent iodine deficiency disorders in humans and livestock. The effects of iodine deficiency, caused by a low content of iodine in the soil and therefore diet, can be totally eradicated by adding 150-200 micrograms of

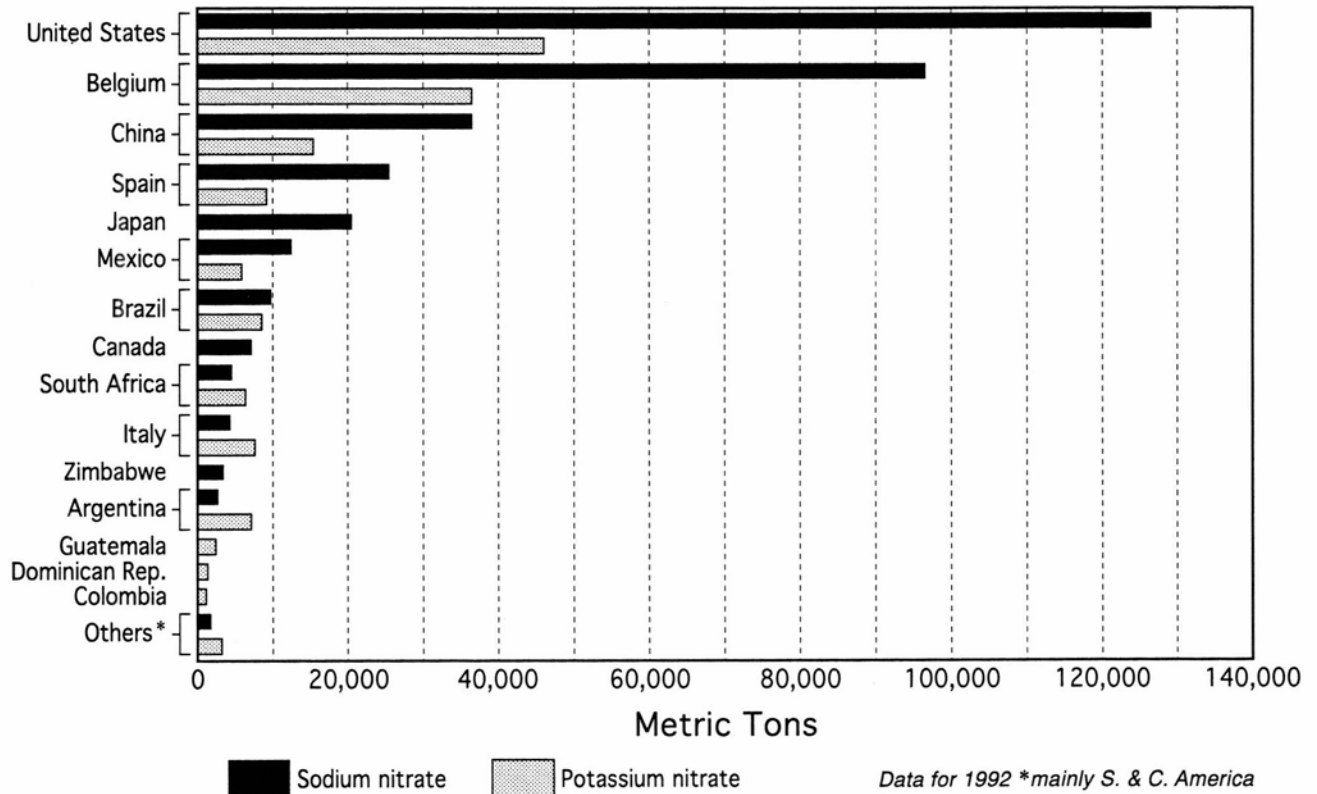

FIGURE 12—Chilean exports of potassium nitrate and sodium nitrate (mt).

TABLE 8—Specifications of nitrates from Chile. After SQM Nitratos S.A.

	Sodium nitrate (16-0-0)		Sodium potassium nitrate (15-0-14)		Magnesium sodium nitrate		Sodium nitrate (industrial grade)		Technical sodium nitrate		Refined sodium nitrate		Potassium nitrate prilled		Potassium nitrate standard	
	NaNO <sub>3</sub>	NaNO <sub>3</sub>	NaNO <sub>3</sub> +KNO <sub>3</sub>	NaNO <sub>3</sub> +MgO	NaNO <sub>3</sub>	NaNO <sub>3</sub>	NaNO <sub>3</sub>	NaNO <sub>3</sub>	NaNO <sub>3</sub>	NaNO <sub>3</sub>	NaNO <sub>3</sub>	NaNO <sub>3</sub>	NaNO <sub>3</sub>	KNO <sub>3</sub>	KNO <sub>3</sub>	KNO <sub>3</sub>
<b>Chemical analysis</b>																
Nitrogen (N), min.	16%	15%		15%										13.50%	13.50%	
Sodium nitrate (NaNO <sub>3</sub> )	96.8-97.9	64-66%					98%			99.20%						
Potassium oxide (K <sub>2</sub> O)	0.4-1.2%	14% min		0.50%										44% min.	45% min.	
Potassium nitrate (KNO <sub>3</sub> )		30%-32%														
Sodium (Na)	26%	18%		24%												
Magnesium oxide (MgO)	0.10%	0.10%		5.5% min												
Sulfur (S)	0.10%	0.10%		0.10%												
Sodium chloride (NaCl)							0.8% max			0.3% max						
Chloride (Cl)	1% max	0.8% min		1% min												
Iron (Fe)																
Sodium nitrite (NaNO <sub>2</sub> )																
Sodium sulfate (Na <sub>2</sub> SO <sub>4</sub> )							0.05% max			0.005% max						
Moisture (H <sub>2</sub> O)	0.15% max						0.35% max			0.10% max						
Insolubles	0.15%	0.15%					0.15% max			0.15% max				0.50% ma	0.10% ma	
Sodium tetraborate (Na <sub>2</sub> B <sub>4</sub> O <sub>7</sub> )							0.15% max			0.02% max				0.10% ma	0.04% ma	
Boric acid (H <sub>3</sub> BO <sub>3</sub> )							0.03% max			0.03% max						
Boron (B)	0.035% max.	0.30%					0.025% max									
<b>Screen (Tyler mesh)</b>																
plus 8 (2.38 mm)	10%	20%		20%			8%			5%				45%		
plus 10 (1.68 mm)	70%	70%		70%			65%			45%				86%		
plus 14 (1.19 mm)	96%	97%		97%			96%			90%				99%		
plus 35 (0.42 mm)																3%
plus 100 (0.149 mm)																62%
plus 150 (0.105 mm)																83%
plus 200 (0.074 mm)																91%
minus 20 (0.841 mm)	1.50%	1.00%		1.00%			2%			8%				0.10%		



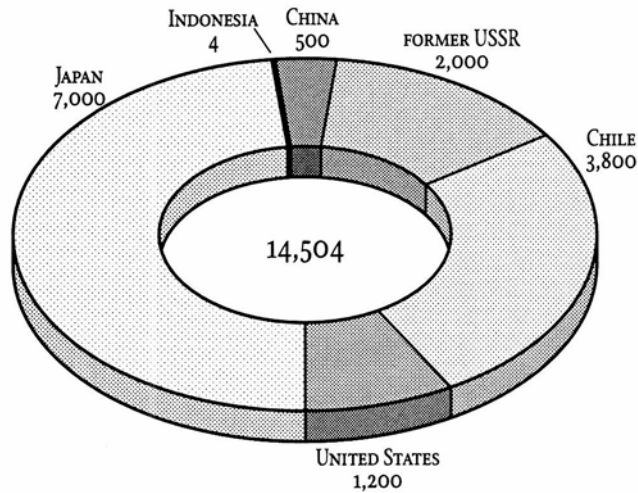

FIGURE 13—World production capacity of iodine (mt). After Lyday (1991).

iodine (generally as sodium or potassium iodide/iodate per capita per day, which is equivalent to one teaspoon per *lifetime*) to the diet through edible salt (or salt licks for animals). Potassium iodide is also used as a heat stabilizer in the manufacture of nylon, for converting rosins, tall oil, and other wood products to a more stable form, as an effective germicide, a developer in radiographic X-ray film, a catalyst, in inks and dyes, and in sanitation products. It is present in a host of ultramodern wares ranging from quartz-iodine lights to sodium-iodine scintillation crystals used in Geiger counters and in cloud seeding.

Exports of nitrates have increased in recent years to more than 665,000 mt/yr, including the recently introduced mixed fertilizers. The main destinations are the United States, Mexico, Brazil, Bolivia, Belgium, Italy, China, and Japan (Fig. 12). Chile is the second largest producer of iodine and the only commercial non-brine source (Fig. 13). The iodine in the caliche ore occurs largely as the minerals lautarite,  $\text{CaI}_2\text{O}_6$ , and dietzite,  $\text{CaO}\cdot\text{I}_2\text{O}_5\cdot\text{CrO}_3$ . The ore has an average iodine content of 0.04%; each 0.91 mt of caliche ore mined yields 34 kg of potassium nitrate, 6 kg of sodium sulfate, and 0.4 kg of iodine. Iodine is extracted by leaching with an alkaline solution to form sodium iodate, which concentrates as the sodium nitrate crystallizes. The sodium-iodate solution drawn off is treated with sodium-bisulfite solution to reduce the iodate to iodide, and iodine is precipitated by the addition of fresh sodium iodate. The precipitate is filtered, washed, dried, and for certain grades purified further by sublimation. Figure 14 summarizes the location of the main salars and nitrate plants in Chile.

### Conclusions

The Latin American region offers investors the potential for business development and at the same time business disaster. Regional growth rates provide a firm foundation for increased demand of industrial minerals ranging from fillers to fertilizers, and the natural mineral wealth and diversity of many countries allow for the possibility of self-sufficiency and export market share. The industry can build on the existing mineral industry including those minerals covered in this paper. However, the political instability and fiscal upheavals experienced recently in Mexico can easily spread to create an



FIGURE 14—Chilean salars and nitrate fields. After Harben and Bates (1990); adapted from Ericksen (1981).

atmosphere of uncertainty that rapidly undermines investment. Nevertheless, there can be no doubt that industrial minerals, being market driven, are prime targets for development and the crucial means of developing this challenging region.

### References

- Aleva, G. J. J., 1982, Bauxites and laterites on the Guiana Shield and its sediment covered margins; *in* Lyew-Ayee, A. (ed.), Proceedings of bauxite symposium V: Journal of the Geological Society of Jamaica, pp. 83-99.
- Aleva, G. J. J., 1984, Laterization, and cyclic landscape development in the Guiana Shield; *in* Jacob, L., Jr. (ed.), Bauxite, Proceedings of 1984 bauxite symposium: American Institute of Mining, Metallurgical, and Petroleum Engineers Inc., Los Angeles, pp. 297-318.
- Barker, J. M., and Lefond, S. J., 1985, Boron and borates: Introduction and exploration techniques; *in* Barker, J. M., and Lefond, S. L. (eds.), Borates—Economic geology and production: Society of Mining Engineers of the American Institute of

- Mining and Metallurgical Engineers Inc. Symposium, Denver, Colorado, pp. 27-34.
- Bleackley, D., 1959, Status of investigations into the bauxite deposits of British Guiana: Proceedings of Fifth Inter-Guiana Conference, pp. 213-227.
- Bleackley, D., 1964, Bauxites and laterites of British Guiana: Geological Survey of British Guiana, Bulletin 34, 156 pp.
- Bourne, H. L., 1994, Glass raw materials; *in* Carr, D. D. (ed.), Industrial minerals and rocks, 6th ed.: Society for Mining, Metallurgy, and Exploration Inc., Littleton, Colorado, pp. 543-550.
- Crozier, R. D., 1987, The Chilean nitrate industry vs the U.S. Department of Commerce: Industrial Minerals, no. 237, pp. 62-67.
- Dickson, T., and Harben, P., 1986, Refractory bauxite; *in* Dickson, E. M. (ed.), Raw materials for the refractories industry, 2nd ed.: Industrial Minerals, pp. 70-75.
- Ericksen, G. E., 1981, Geology and origin of the Chilean nitrate deposits: U.S. Geological Survey, Professional Paper 1188, 37 pp.
- Ericksen, G. E., 1983, The Chilean nitrate deposits: American Scientist, v. 71, pp. 366-374.
- Harben, P. W., 1992, Industrial minerals handybook: A guide to markets, specifications, and prices: Industrial Minerals Division, Metal Bulletin Plc, London, 147 pp.
- Harben, P. W., 1995, Industrial minerals handybook II: A guide to markets, specifications, and prices: Industrial Minerals Division, Metal Bulletin Plc, London, 254 pp.
- Harben, P. W., and Bates, R. L., 1990, Industrial minerals—Geology and world deposits: Industrial Minerals Division, Metal Bulletin Plc, London, 312 pp.
- Harben, P. W., and Dickson, E. M., 1985, Overview of market outlook and economics of borates; *in* Barker, J. M., and Lefond, S. J. (eds.), Borates—Economic geology and production: AIME Symposium, Denver, Colorado, pp. 3-12.
- Hinds, S. A., 1983, Refractory bauxite; *in* Dickson, E. M., and Harben, P. W. (eds.), Minerals in the refractories industry—Assessing the decade ahead: Industrial Minerals, no. 187, pp. 55-60.
- Hinds, S. A., Ralph, B., and Pollard, B., 1982, South American refractory grade bauxite—A guaranteed supply of high alumina refractory grog well into the 21st century; *in* Proceedings of Raw Materials for Refractories Conference: University of Alabama, Tuscaloosa, Alabama, pp. 35-56.
- Kistler, R. B., and Smith, W. C., 1983, Boron and borates; *in* Lefond, S. J. (ed.), Industrial minerals and rocks, 5th ed.: Society of Mining Engineers of the American Institute of Mining and Metallurgical Engineers Inc., New York, pp. 533-560.
- Lyday, P. A., 1991, Boron; *in* Minerals Yearbook: U.S. Bureau of Mines, v.1, p. 295.
- Moses, J. H., and Michell, W. D., 1963, Bauxite deposits of British Guiana and Surinam in relation to underlying unconsolidated sediments suggesting two-step origin: Economic Geologist, v. 58, pp. 250-262.
- Muessig, S., 1968, Recent South American borate deposits; *in* Rau, J. L. (ed.), Proceedings of 2nd Symposium on Salt, Volume 1: Northern Ohio Geological Society, Cleveland, Ohio, pp. 151-159.
- Norman, J. C., and Santini, K. N., 1985, An overview of occurrences and origin of South American borate deposits with a description of the deposit at Laguna Salinas, Peru; *in* Barker, J. M., and Lefond, S. J., (eds.), Borates—Economic geology and production: Society of Mining Engineers of the American Institute of Mining and Metallurgical Engineers Inc. Symposium, Denver, Colorado, pp. 53-69.
- Patterson, S. H., 1967, Bauxite reserves and potential aluminum resources of the world: U.S. Geological Survey, Bulletin 1228, 176 pp.
- Pickering, S. M., and Murray, H. H., 1994, Kaolin; *in* Carr, D. D. (ed.), Industrial minerals and rocks, 6th ed.: Society for Mining, Metallurgy, and Exploration Inc., Littleton, Colorado, pp. 255-277.
- Trivedi, N. C., and Hagemeyer, R. W., 1994, Fillers and coatings; *in* Carr, D. D. (ed.), Industrial minerals and rocks, 6th ed.: Society for Mining, Metallurgy, and Exploration Inc., Littleton, Colorado, pp. 483-495.

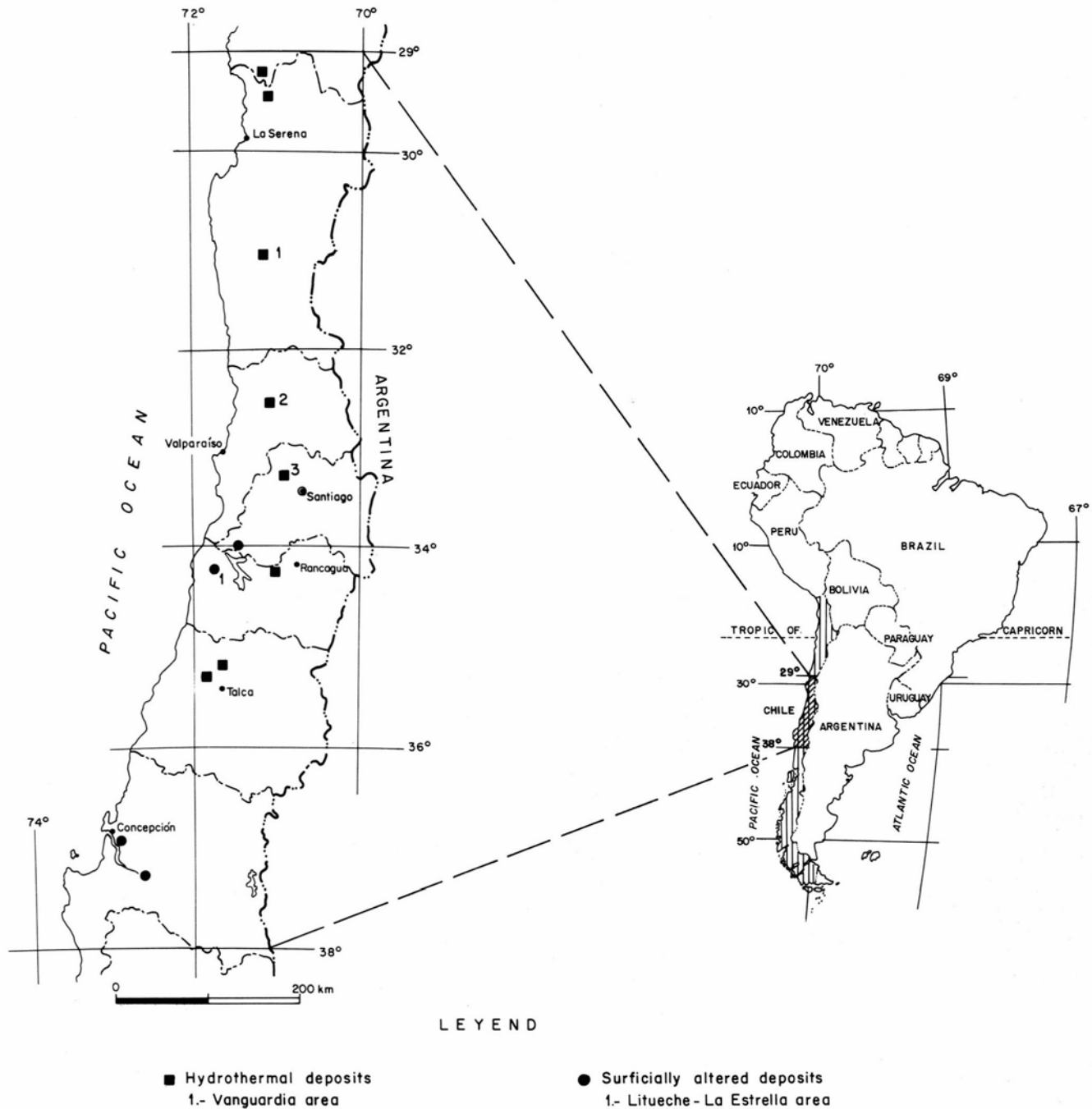

FIGURE 1—Location map of hydrothermal and residual kaolin deposits in Chile.

### Selected hydrothermal kaolin deposits

The most important and best studied hydrothermal kaolin deposits are those in the Vanguardia, Chincolco-Petorca, and Til Til areas north of Santiago, the capital city of Chile (Fig. 1). These deposits are in hydrothermal alteration zones in andesites, rhyolites, and breccias of the Las Chilcas Formation of Early Cretaceous age and are related to granitic rocks of Early to Late Cretaceous age (Thomas, 1958; Rivano et al., 1993). Porphyritic andesites and rhyolites are the principal volcanic rocks affected by intermediate and advanced argillic alteration processes. The veins and irregular bodies, 0.2-10 m wide and 10-100 m long, are the most important deposits in these areas. The main faults and fractures trend from north

south to N20°E, from N20°W to N45°W, and east-west, with an average density of 6-10 fractures /m<sup>2</sup>. Thus, kaolin mineralization is controlled both by lithology and structure. Kaolin color varies from white to light yellow and red, to light gray and gray, according to the degree of alteration and to Fe<sub>2</sub>O<sub>3</sub> and TiO<sub>2</sub> content. The major-element chemical compositions used to define their origin and chemical uses are presented in Tables 1-3.

As a raw material, the kaolin from the Vanguardia area (Fig. 2) has an average alumina content of 27-32 wt.% Al<sub>2</sub>O<sub>3</sub> and a primary mineralogy of kaolinite, quartz, and illite (Table 1). This kaolin is used for ceramics and as a filler in paints. Kaolin from the Chincolco—Petorca area (Fig. 3) contains 23-31 wt.% Al<sub>2</sub>O<sub>3</sub> and is composed of

TABLE 1—Chemical constituents (in wt.%) and mineralogical composition of the Vanguardia kaolin deposits.

Chemical analysis	Formerly exploited workings <sup>1</sup>	Exploration samples <sup>2</sup>	Currently exploited workings <sup>3</sup>
SiO <sub>2</sub>	52.50	58.19	50.49
Al <sub>2</sub> O <sub>3</sub>	27.03	29.72	32.49
Fe <sub>2</sub> O <sub>3</sub>	1.81	0.81	1.19
TiO <sub>2</sub>	0.86	0.72	0.52

**X-ray analysis**

—	Kaolinite	Kaolinite
	Quartz	Quartz
	Illite	Illite

<sup>1</sup>CORFO (1972); <sup>2</sup>Espiñeira et al. (1984); <sup>3</sup>BRGM-SERNAGEOMIN (1994)

TABLE 2—Chemical constituents (in wt.%) and mineralogical composition of the Chincolco–Petorca kaolin deposits.

Chemical analysis	Chincolco <sup>1</sup>	Petorca <sup>1</sup>	Colosa <sup>2</sup>
SiO <sub>2</sub>	50.30	57.23	61.50
Al <sub>2</sub> O <sub>3</sub>	31.56	27.33	23.60
Fe <sub>2</sub> O <sub>3</sub>	1.55	1.26	1.00
TiO <sub>2</sub>	0.99	0.85	0.50

**X-ray analysis**

Kaolinite	Kaolinite	—
Sericite	Sericite	
Quartz	Quartz	

<sup>1</sup>BRGM-SERNAGEOMIN (1994); <sup>2</sup>Gajardo and Carvajal (1990)

TABLE 3—Chemical constituents (in wt.%) and mineralogical composition of the Til Til kaolin deposits (González, 1987).

Chemical analysis	La Puente	Santa Lucía	María Isabel
SiO <sub>2</sub>	53.21	55.02	54.37
Al <sub>2</sub> O <sub>3</sub>	27.95	25.73	24.37
Fe <sub>2</sub> O <sub>3</sub>	2.70	4.26	0.64
TiO <sub>2</sub>	0.23	—	—

**X-ray analysis**

Kaolinite	Kaolinite	Pyrophyllite
Muscovite	Muscovite	Kaolinite
Quartz	Quartz	Quartz

kaolinite, sericite, and quartz (Table 2). Kaolin from these deposits is ground to a —40 +60 mesh size in a plant nearby and is used as filler in paints and for aluminum sulfate production. Kaolin from the Til Til area (Fig. 4) contains 24–28 wt.% Al<sub>2</sub>O<sub>3</sub> and is mainly composed by kaolinite, muscovite, quartz, and pyrophyllite (Table 3). This raw material is used as a filler in paints and rubber and for refractory bricks.

The hydrothermal origin of these kaolin deposits is well defined by their geological characteristics: veins and irregular bodies, structural and lithological mineralization control, and spatial distribution of kaolin and parent rocks. Their mineralogical composition is a hydrothermal assemblage of kaolinite, quartz, pyrophyllite, and sericite formed by the alteration from feldspar and micas.

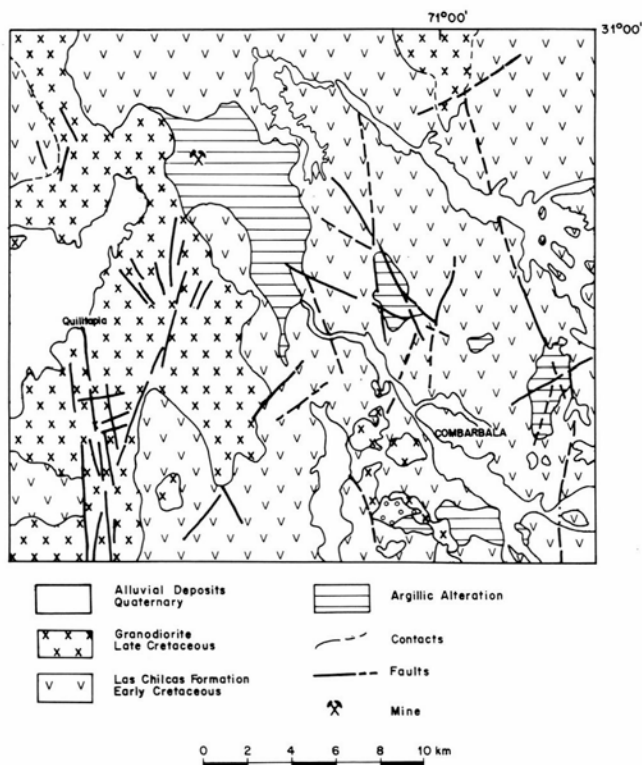

FIGURE 2—Geologic map of Vanguardia area (after Rivano and Sepúlveda, 1986).

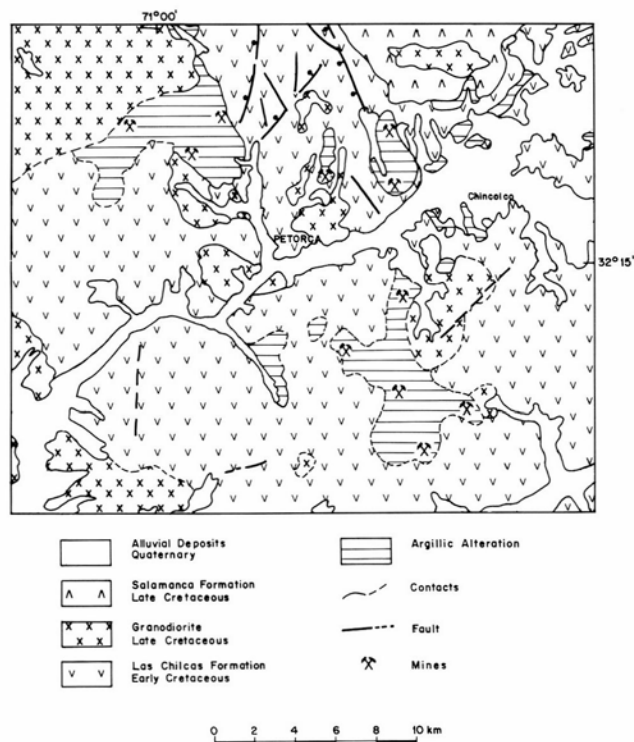
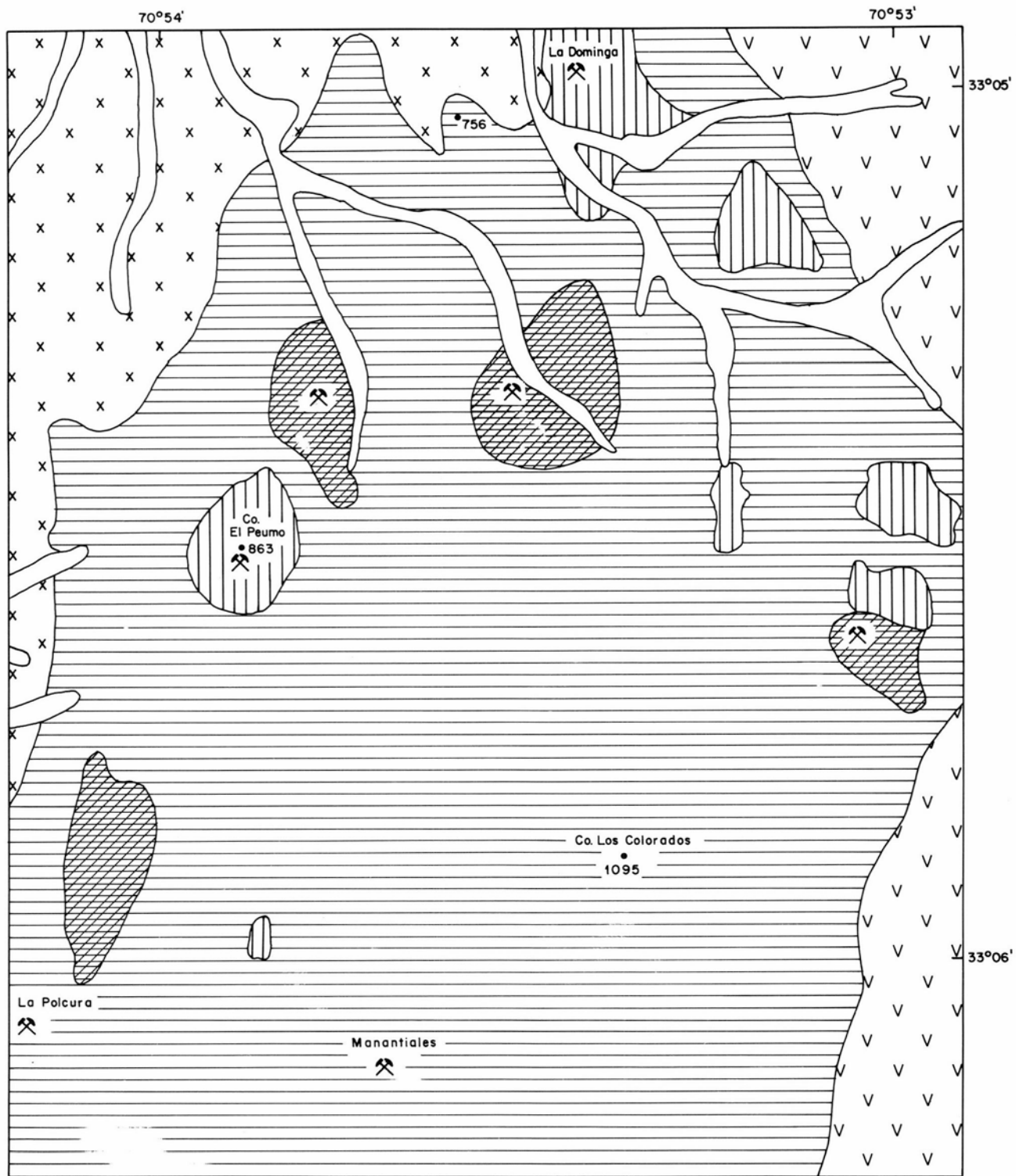

FIGURE 3—Geologic map of Chincolco–Petorca area (after Rivano et al., 1993).

### Kaolin deposits derived from residual concentration

Residual kaolin deposits are by far the most important and best quality source in Chile. Kaolin of this type are produced by a single Chilean company, Minera Pacifico S.A., from its own mines and are beneficiated to produce ceramic-grade kaolin and filler for paper, paints, and rub-



- |   |  |   |                                  |   |          |
|---|--|---|----------------------------------|---|----------|
|  | Alluvial Deposits Quaternary           |  | Intermediate Argillic Alteration |  | Contacts |
|  | Diorite Late Cretaceous                |  | Advanced Argillic Alteration     |  | Mines    |
|  | Las Chilcas Formation Early Cretaceous |  | Silicic Alteration               |   |          |



FIGURE 4—Geologic map of Til Til area (after Gonzáles, 1987).

ber. This production accounts for 8% of the total Chilean annual production. These residual deposits are located in the Coastal Range of Chile, between 34 and 38°S, where granitic rocks of Paleozoic to Triassic age (Muñoz Cristi, 1962; Davila et al., 1979) are the host rocks. Deposits currently being exploited are located in Litueche—La Estrella area (Fig. 1). Other deposits, not yet developed, lie south of this location.

### Selected residual kaolin deposits

The most important and best known of these deposits are those from the Litueche—La Estrella area, 140 km southwest of Santiago (Fig. 1). The original rock for these deposits is a pink-to-reddish feldspar granite of Triassic age (Davila et al., 1979; Fig. 5) that was kaolinized under favorable climatic, lithological, tectonic, and morphological conditions during the Late Tertiary. These mantle de-

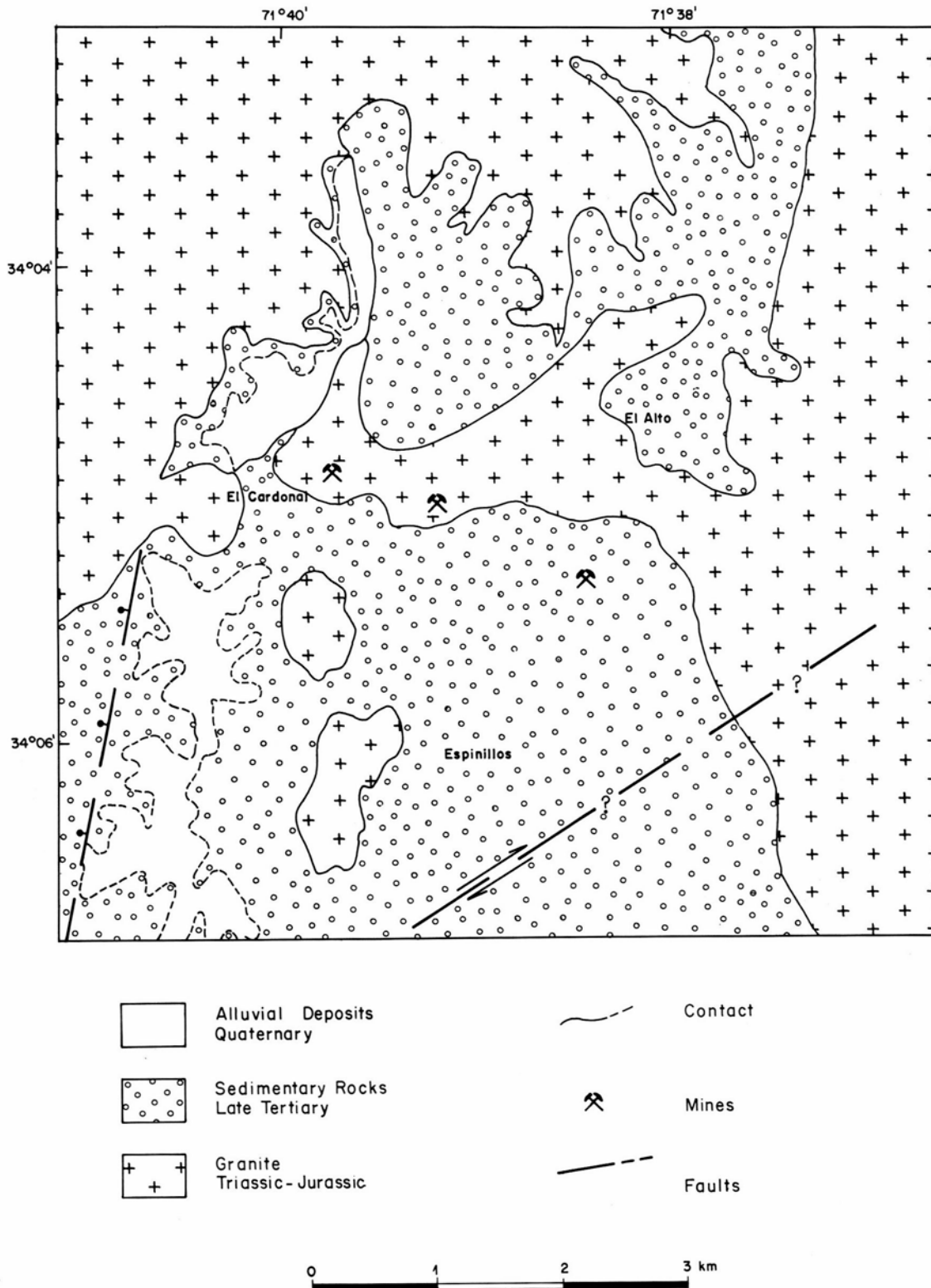

FIGURE 5—Geologic map of Litueche—La Estrella area (modified from Cano, 1974).

posits have a thickness of 10-15 m, with a gradual transition from the altered to the fresh granite, and are often covered by Late Tertiary sedimentary rocks. They lie below a broad peneplain and on granite basement that is dissected by fluvial erosion.

In the Litueche-La Estrella area, kaolin is white to light yellow. The color is controlled by the degree of kaolinization and Fe<sub>2</sub>O<sub>3</sub> and TiO<sub>2</sub> content. The raw kaolin is composed mainly of kaolinite and quartz with 17-24 wt.% Al<sub>2</sub>O<sub>3</sub> and 63-75 wt.% SiO<sub>2</sub>. The major-element chemical composition is presented in Table 4. The geological characteristics of these deposits (manto morphology; climatic, lithological, and morphological mineralization control; and spatial distribution of kaolin and host rocks) and the mineralogical composition of raw kaolin (kaolinite and quartz) confirm its origin as a residual product by kaolinization of granitic rocks.

### Current situation and future uses of Chilean kaolin Hydrothermal kaolins

Hydrothermal kaolins have been used for white ceramics, refractory bricks, and aluminum sulfate production, and as fillers in the paint and rubber industries. The kaolin is produced using simple beneficiation processes, usually grinding and classification. Detailed geological, beneficiation, and chemical studies have not been done on these deposits. The only property that has been considered historically is chemical composition of the kaolin, especially Al<sub>2</sub>O<sub>3</sub> content.

The mineralogical composition including other minerals, principally pyrophyllite and sericite, has not been considered as an important raw-material property, even though the kaolin and pyrophyllite are closely associated in most deposits; veins and/or irregular bodies of these minerals usually coexist. The chemical and mineralogical characteristics suggest additional significant uses for Chilean hydrothermal kaolin such as white ceramics, contact refractories, white cement, safety road-surface aggregates, and refractory mortars. Mineralogy, chemistry, and physical properties, such as particle-size composition and pyrometric cone equivalent (PCE), are the main specifications for these industrial applications (Cornish, 1983; Patterson and Murray, 1983). Comparison of the chemical composition of kaolins from the Vanguardia and Chincolco-Petorca areas to the chemical composition of some well-known pyrophyllite products from different countries (Table 5), indicates significant similarities suggesting that a wider spectrum of new uses and markets for these kaolins is possible.

### Kaolins in residual deposits

Residual kaolin deposits from Litueche-La Estrella are used as fillers in paper, paints, and rubber. They are used in white ceramic production, where physical properties such as whiteness, abrasiveness, and mechanic resistance, are most important. Beneficiation processes, including degrading, classification, filtration, flotation, magnetic separation, and drying, are used to improve mineral qualities for these domestic markets. Although the best domestic and potential foreign markets for this kaolin are in the paper and ceramic industries, the chemical composition of the Chilean kaolin formed by residual concentration is so similar to Japanese and Australian pyrophyllite products that new markets for these kaolins should be considered (Table 6).

TABLE 4—Chemical constituents (in wt.%) and mineralogical composition of the Litueche-La Estrella kaolin deposits (Gajardo and Gutiérrez, 1992).

Chemical analysis	El Olivo	El Litre	Blanquita
SiO <sub>2</sub>	75.42	71.05	63.70
Al <sub>2</sub> O <sub>3</sub>	17.17	19.34	24.35
Fe <sub>2</sub> O <sub>3</sub>	0.27	0.79	0.20
TiO <sub>2</sub>	0.17	0.19	0.15
<b>X-ray analysis</b>			
	Kaolinite	Kaolinite	Kaolinite
	Quartz	Quartz	Quartz

TABLE 5—Chemical composition (in wt.%) of Chilean hydrothermal kaolin deposits and main pyrophyllite products.

Chemical analysis	Brazil <sup>1</sup> pyrophyllite	Vanguardia <sup>2</sup> kaolin	USA <sup>1</sup> pyrophyllite	Chincolco- Petorca <sup>2</sup> kaolin
SiO <sub>2</sub>	63.64	63.00	57.58	56.91
Al <sub>2</sub> O <sub>3</sub>	25.59	29.20	33.31	28.67
Fe <sub>2</sub> O <sub>3</sub>	—	<1.00	0.33	0.62
CaO	—	0.06	tr	0.08
MgO	0.01	0.43	tr	0.28
K <sub>2</sub> O	2.48	3.00	3.90	2.60
Na <sub>2</sub> O	0.29	0.09	0.06	0.11

<sup>1</sup>Ceramic grade (Harben, 1992); <sup>2</sup>BRGM-SERNAGEOMIN (1994)

TABLE 6—Chemical composition (in wt.%) of Chilean residual kaolin deposits and main pyrophyllite products.

Chemical analysis	Japan <sup>1</sup> pyrophyllite	Litueche- La Estrella <sup>2</sup> (El Olivo) kaolin	Australia <sup>3</sup> pyrophyllite	Litueche- La Estrella <sup>2</sup> (El Litre) kaolin
SiO <sub>2</sub>	75.76	75.42	75.70	71.05
Al <sub>2</sub> O <sub>3</sub>	17.68	17.17	18.80	19.34
Fe <sub>2</sub> O <sub>3</sub>	0.11	0.27	0.38	0.79
CaO	0.28	0.07	0.30	0.05
MgO	0.01	0.07	0.12	0.07
K <sub>2</sub> O	0.04	0.05	0.24	0.18
Na <sub>2</sub> O	0.10	0.06	0.11	0.05
TiO <sub>2</sub>	0.18	0.17	0.39	0.19

<sup>1</sup>Refractory grade (Harben, 1992); <sup>2</sup>Gajardo and Gutiérrez (1992); <sup>3</sup>BRGM-SERNAGEOMIN (1994)

### Acknowledgements

The author highly appreciates comments to present paper by Dr. Robert J. Lickus, from G.P.I. Holding, Inc., USA, and Dr. Jose Corvalán D., from Servicio Nacional de Geología y Minería, Chile.

### References

- Bureau de Recherches Géologiques et Minières, Servicio Nacional de Geología y Minería (BRGM-SERNAGEOMIN), 1994, Carta Metalógica de las Regiones V/IV Sur: Informe Registrado, escala 1:250,000.
- Cano, J., 1974, Mapa geológico yacimientos de caolín de Rosario de Lo Solís (Litueche): Proyecto II, Departamento de Geología, Universidad de Chile, Inédito, 12 pp.
- Cornish, B. E., 1983, Pyrophyllite; in Lefond, S. J. (ed.), Industrial minerals and rocks, 5th ed.: Society of Mining Engineers, American Institute of Mining, Metallurgical and Petroleum Engineers Inc., New York, pp. 1085-1108.
- Corporación de Fomento de la Producción (Chile; CORFO), 1972,



- Programa de desarrollo de los minerales de use en las industrial cerámicas y refractarias: I Seminario Nacional de Recursos No Metálicos, Jquique, Chile, 162 pp.
- Davila, A., Hervé, F., y Munizaga, F., 1979, Edades K/Ar en granitoides de la Cordillera de la Costa de la provincia de Colchagua, VI Región, Chile Central: Actas II Congreso Geológico Chileno, Tomo I, pp. F107—F120.
- Espiñeira, D., Fuenzalida, G., Harambour, S., Nunez, R., Sanchez, G., Siña, A., y Soffia, M., 1984, Estudio geológico preliminar de recursos no metálicos entre Santiago y Combarbalá, Regions IV, V y Metropolitana: Curso yacimientos No Metálicos, Departamento de Geología, Universidad de Chile, Inédito, 61 pp.
- Gajardo, A., y Carvajal, H., 1990, Estudio, desarrollo y producción de baritinas y caolines para la industria manufacturers nacional: Minería Chilena, N°113, Noviembre, 5 pp.
- Gajardo, A., y Gutierrez, A., 1992, Exploración de recursos no metálicos en la VI Región: Intendencia VI Región, Servicio Nacional de Geología y Minería, Informe Registrado, 112 pp.
- Gonzalez, E., 1987, Prospección y evaluación de yacimientos de caolín, cuarzo y caliza en el sector de Til Til, Región Metropolitana: Memoria para optar al Título de Geólogo, Departamento de Geología, Universidad de Chile, 114 pp.
- Patterson, S. H., and Murray, H. H., (revised by Murray, H. H.), 1983, Clays; *in* Lefond, S. J. (ed.), Industrial minerals and rocks, 5th ed.: Society of Mining Engineers, American Institute of Mining, Metallurgical and Petroleum Engineers Inc., New York, pp. 585-651.
- Harben, P. W., 1992, The industrial minerals handybook: Industrial Minerals Division, Metal Bulletin Plc, London, 148 pp.
- Munoz Cristi, J., 1962, Comentarios sobre los granitos chilenos: Revista Minerales N°78, pp. 15-19.
- Rivano, S., y Sepulveda, P., 1986, Hoja Illapel: Servicio Nacional de Geología y Minería (Chile), Carta Geológica de Chile, No. 69, escala 1:250.000.
- Rivano, S., Sepulveda, P., Boric, R., y Espiñeira, D., 1993, Hojas Quillota y Portillo: Servicio Nacional de Geología y Minería (Chile), Carta Geológica de Chile, No. 73, escala 1:250,000.
- Thomas, H., 1958, Geología de la Cordillera de la Costa entre el valle de La Ligua y la cuesta de Barriga: Instituto Investigaciones Geológicas (Chile), Boletín 2, 86 pp.



# Economic geology of Cretaceous deposits in Nova Scotia

Kimberly A. MacLeod

(Student Scholarship Recipient)

1 Quaker Crescent, Lower Sackville, Nova Scotia B4C 2Z1, Canada

**Abstract**—Unconsolidated Lower Cretaceous deposits in Nova Scotia consist of alternating beds of silica sand, silt, and refractory clay with minor amounts of lignite and gravel. Isolated outcrops of these sediments are found in previously developed Carboniferous structural basins where Quaternary glacial drift is thin. The Cretaceous sediments have been interpreted as fluvial or deltaic deposits.

Silica sand and clay from several of these deposits have played a significant role in the industrial mineral production of Nova Scotia for more than a century. Currently, Shaw Resources of Shubenacadie and Shaw Brick of Lantz, both in Hants County, are the only companies exploiting these sediments in the province. Kaolinitic clay associated with these deposits have not been economically evaluated and may prove a minable commodity.

## Geologic económica de depósitos cretácicos en Nova Scotia

**Resumen**—Depósitos no consolidados del Cretácico Inferior de Nova Scotia consisten de capas alternadas de arena silicica, silt y arcilla refractaria con ocurrencias menores de lignito y pedregullo. Afloramientos aislados de estos sedimentos se encuentran en cuencas estructurales del Carbonifero cubiertas por depósitos glaciales cuaternarios de poco espesor. Estos sedimentos cretácicos han sido interpretados como depósitos fluviales o deltaicos.

Por más de cien años, las arenas silicicas y arcillas de varios de estos depósitos cretácicos han sido una parte importante de la producción de minerales industriales en Nova Scotia. En la actualidad, *Shaw Resources* de Shubenacadie y *Shaw Brick*, ambas en el Condado de Hants, son las únicas empresas que explotan estos sedimentos en Nova Scotia. Arcilla caolinitica asociada con estos depósitos no ha sido investigada en cuanto a su valor económico y podria ser un recurso explotable.

### Introduction

Diversity of Nova Scotia's geology has played an important role in making the mineral industry successful. This diversity allows various rock types to be used for

mineral production. Deposits of silica sand and clay of Cretaceous age are known to exist in seven distinct areas in Nova Scotia (Fig. 1). This report focuses on central Nova Scotia and the production that has occurred as a result of

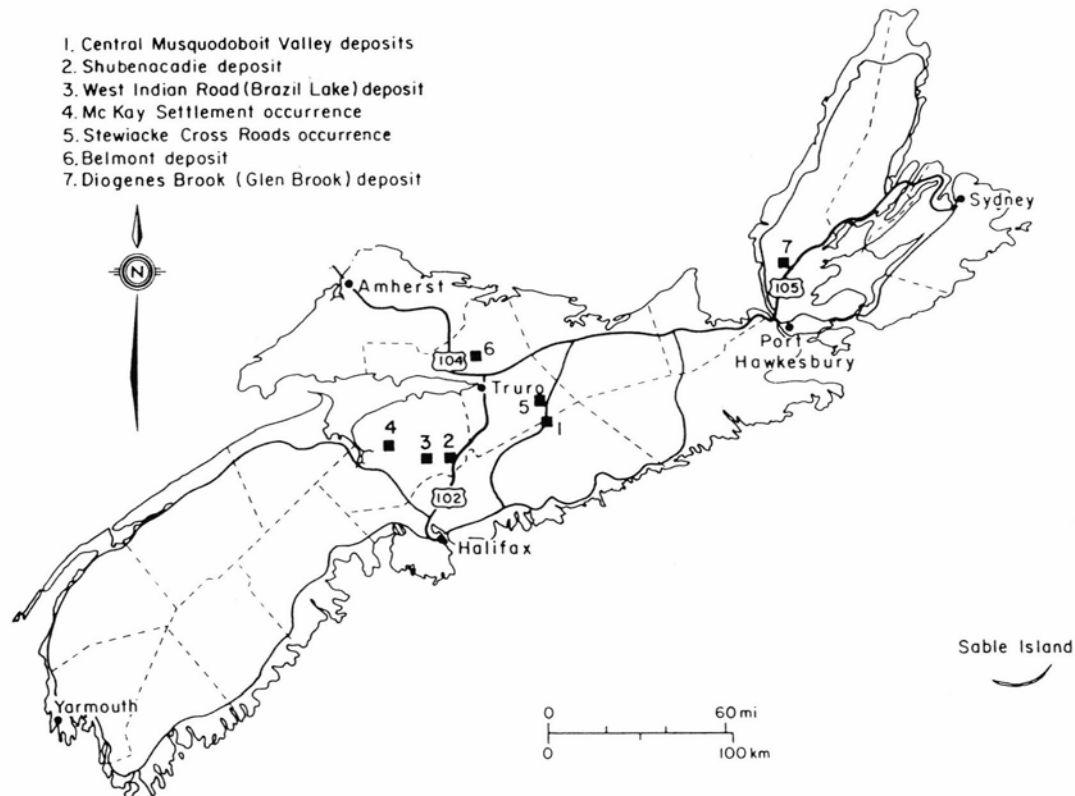

FIGURE 1—Cretaceous deposits in Nova Scotia (after Dickie, 1986).

utilization of these resources. The focus of current research is to develop estimates of commodity reserves for future production.

General geology

Unconsolidated Cretaceous sediments in central Nova Scotia are preserved in small isolated pockets in basins previously developed in Carboniferous time. They consist of alternating clay, silt, sand, and local lignite beds. Considerable variation in sequence from site to site is ob-

served. The total thickness of these sediments is up to 300 m. Microspore analysis determined that these sediments were of Early Cretaceous age (Lin, 1971). This was confirmed by palynological analysis (Fowler and Stea, 1984). Dickie (1986) described the deposits as being deposited in the fluvial or deltaic environment associated with a shallow body of standing water. The accumulation of material was the result of regional transgressions associated with the Lower Cretaceous Logan Canyon Formation in the offshore stratigraphy that thins progressively to the east.

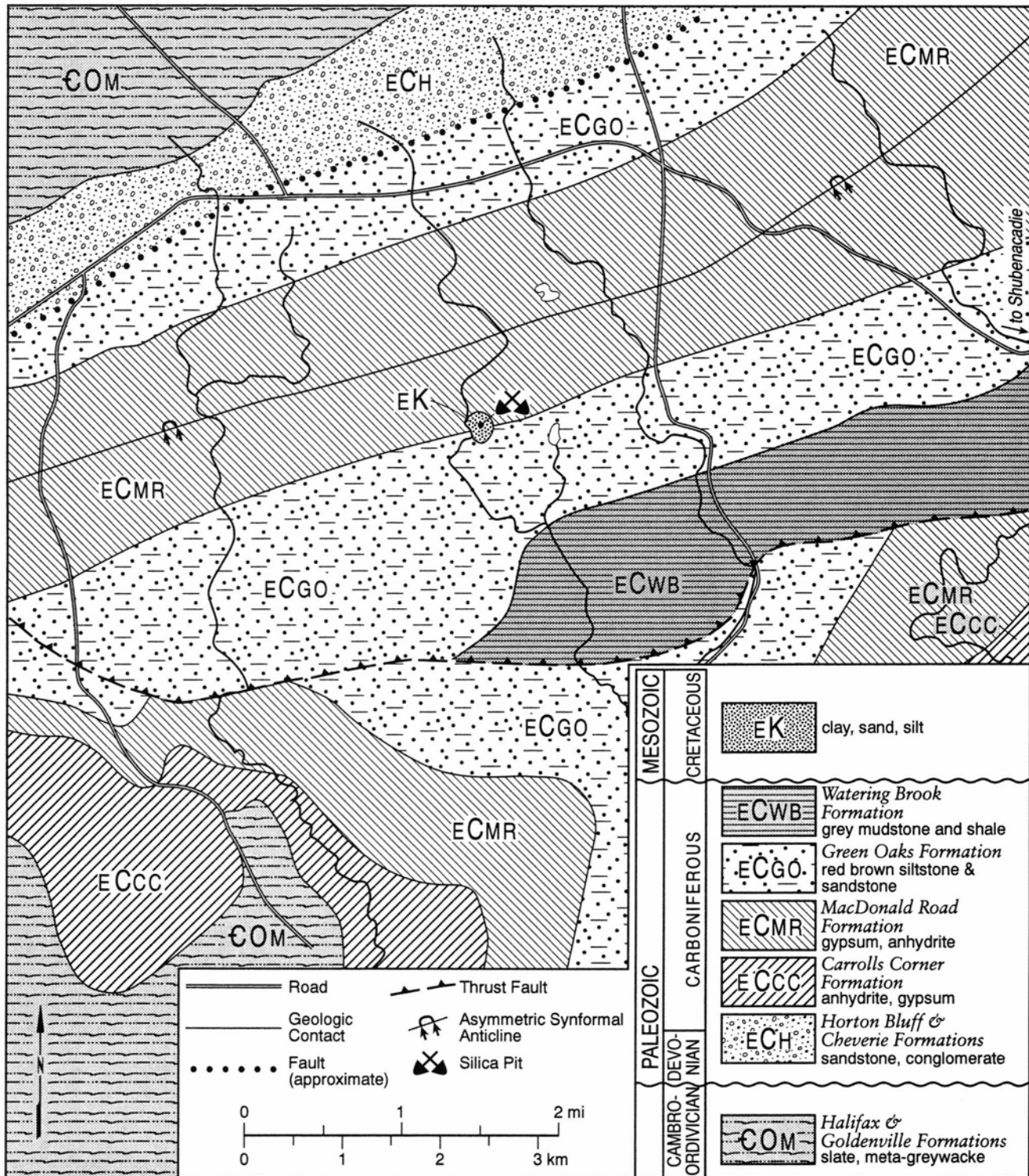

FIGURE 2—Silica sand deposit, West Indian Road (after Dickie, 1986).

Subsequently, most of the Cretaceous sediments were removed by erosion. The remaining beds were covered by late Wisconsinan glacial debris. These Nova Scotia sediments bear a striking similarity to the Lower Cretaceous clays found in New Jersey, and, like them, contain lignite (Ries, 1911).

### Production history

Nova Scotians have historically utilized various industrial minerals that have supplied commodities for local, interprovincial, and international markets. Industrial minerals account for 49.3% of Nova Scotia's total mineral production. Currently, the only producers of silica sand and clay in Nova Scotia are Shaw Resources and Shaw Brick, both in Hants County (Fig. 1, deposits 2 and 3, respectively).

Shaw Resources owns and has operated a silica sand pit at West Indian Road since the mid-1970s (Fig. 2). In the pit the Cretaceous beds have a general northeast strike and dip 30-50° northwest. The pit reveals a striking sequence of brightly colored sediments in unconformable contact with the overlying Pleistocene heavy red clay till (Dickie, 1992). The till's contrasting color is due to its component of cobbles and stones from various local rock types. Shaw Resources manufactures 20 different silica sand products at their plant in Shubenacadie including a glass-grade sand used in New Brunswick by Consumers Packaging. Other uses for the West Indian Road sand include: an industrial abrasive, filter sand, and as a fluxing agent. After washing, drying, and screening, sand for glass manufacture is brought up to specifications by being passed over two double-roll Eriez high-intensity magnetic separators (Fig. 3). Silica sand production in 1993 was 40,000 metric tons (mt).

Shaw Brick uses the clays for the production of structural clay products. These products consist of bricks (common and face), drain tile, flue lining, and sewer pipe. In 1994 Shaw Brick manufactured approximately 20,000,000 bricks. In comparison to brick production, the other clay products represent only a minor component to total structural clay product manufacturing. Annual production numbers vary depending on brick production, market price, and consumer demand.

### Current research

A recent drilling program and seismic study by geologists of the Nova Scotia Department of Natural Resources and the Geological Survey of Canada has revealed that the Cretaceous deposits in central Nova Scotia are more extensive than previously thought. The discovery of Lower Cretaceous silica sand and clay resources in areas beneath a thick till cover could have a direct impact on production by local manufacturers and influence any future industry expansion. This research has enabled a detailed stratigraphic description to be constructed that identifies additional areas of exploration of these Cretaceous resources.

A fining upward sequence, with beds of "white clay" interstratified between the coarser-grained Cretaceous deposits, consists dominantly of kaolin (Stea and Fowler, 1980). Chemical analyses reveal that the clay is characteristic of secondary kaolinitic clay-bearing units. Once the quality (percent of impurities) and quantity of the clay have been determined and beneficiation procedures have been identified, it may be of economic importance. The interstratified silica sand layers also appear to have a large volume of kaolinite present (R. Stea, Nova Scotia Department of Natural Resources, pers. comm. 1995). If it could

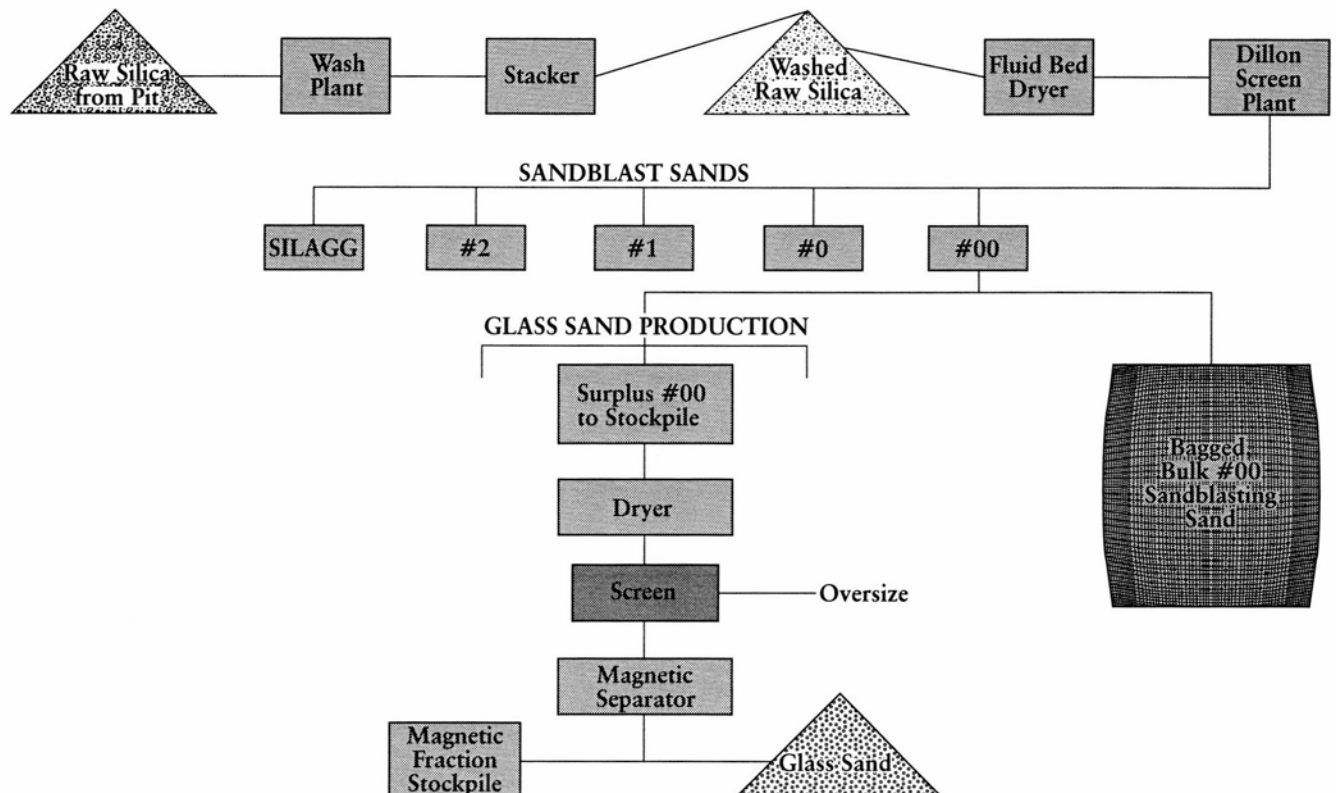

FIGURE 3—Flow chart of silica sand production of the Silica Sand Plant of Nova Scotia Sand and Gravel at Shubenacadie, Nova Scotia, Canada (after Dickie, 1992).

be concentrated with beneficiation at a relatively low cost, local use of kaolin could be developed. The success of this nonrenewable industry will ultimately be determined by the quality and extent of these Cretaceous deposits.

### Conclusions

Lower Cretaceous resources in Nova Scotia, although small in volume, have a significant impact on the success of the mineral industry. Silica sand and clay are nonrenewable resources, and new deposits have to be found to replace those currently being consumed. Industrial mineral producers face two main challenges when determining future production: (1) conflicting land-use needs; and (2) increasing competition from products on a global scale (Dickie, 1992). Consumption of silica from mined deposits by the glass container industry has been negatively affected by the recycling of glass. Utilizing waste material from other mineral processes by advanced technology allows quality products to be produced, balancing out impacts by recycled glass. New information on Cretaceous deposits in the province should help to establish new resources and secure the industry for future consideration.

### Acknowledgements

Grateful acknowledgements are made to the following people: John Fowler, J. H. Fowler and Associates, whose

insight and industry experience made this paper possible; Ralph Stea, Nova Scotia Department of Natural Resources, for information on current drilling progress and ideas; and Garth Prime and Gordon Adams for listening to my ideas and offering valuable criticism.

### References

- Dickie, G. B., 1986, Cretaceous deposits of Nova Scotia: Nova Scotia Department of Mines and Energy, Paper 86-1, pp. 3-22.
- Dickie, G. B., 1992, Industrial minerals for the future, producing quality products from waste: Canadian Institute of Mining, Eighth District Meeting, Halifax, Nova Scotia, pp. 1-12.
- Fowler, J. H., and Stea, R., 1984, Cretaceous clay and sand deposits in central Nova Scotia; *in* The geology of industrial minerals in Canada, Special Volume 29: Harpell's Press Cooperative, Quebec, pp. 22-32.
- Lin, C. L., 1971, Cretaceous deposits in the Musquodoboit River valley, Nova Scotia: Canadian Journal of Earth Science, v. 8, pp. 1152-1154.
- Ries, H., 1911, Clays in Musquodoboit Valley at Shubenacadie; *in* The clay and shale deposits of Nova Scotia and portions of New Brunswick: Geological Survey of Canada, Memoir 16—E, pp. 75-87.
- Stea, R. R., and Fowler, J. H., 1980, Petrography of Lower Cretaceous silica sands at Brazil Lake, Hants County, Nova Scotia; *in* Fourth annual open house and review of activities, program and summaries: Nova Scotia Department of Mines and Energy, Information Series 03, pp. 49-54.

# The Mount Gelai hectorite deposit, Arusha District, Tanzania, East Africa

Ted H. Eyde

*GSA Resources, Inc., 7660 N. Business Park Drive, Tucson, Arizona 85743, USA*

**Abstract**—The Mount Gelai hectorite deposit consists of three known outcrops of saponite on the east side of Lake Natron, a saline–alkaline lake in northern Tanzania. The deposits are at an elevation of 2,000 ft above sea level about 3° south of the equator and 534 mi northwest of the port city of Dar-es-Salaam. The deposits are accessible from the railhead of Arusha over 40 mi of paved and 92 mi of a nearly impassable dirt road known as the "Smugglers Trail."

All of the deposits occur in active, alkaline, thermal-spring areas. The heat source for these springs is near-surface hot magma that feeds volcanoes along the rift valley. The active volcano 01 Doiyo Lengai is at the south end of Lake Natron about 40 mi south of the deposit. Mount Gelai is an inactive volcano on the east side of Lake Natron, and the Nguruman Scarp is on the west side. The difference in elevation between Lake Natron and the top of the rift and volcanoes ranges from 6,000 to 9,000 ft.

Saponite occurs in a 3 ft thick bed overlain in most places by a magnesite bed, or by unconsolidated volcanic ash where the magnesite has been eroded. Previous investigators identified the clay minerals in the deposit as hectorite. In fact, the clay mineral is a very pure saponite that is white to light brownish white and nearly translucent. It closely resembles candle wax, which because of its plasticity can be molded into shapes, hence the local name "plastic magnesite." The crude wet saponite is about 40% moisture. The principal gangue minerals are magnesite and rhodochrosite. When exposed to sunlight and dry air at the deposit, samples of the saponite quickly dry into a high-brightness white powder. The Gelai deposits contain a possible reserve of 280,000 short tons (st) of crude wet saponite in three deposits. The north deposit contains 20,000 st, the middle deposit 30,000 st, and the south deposit 230,000 st.

## El yacimiento de hectorita de Mount Gelai, Distrito de Arusha, Tanzania, Africa del Este

**Resumen**—Este yacimiento consiste de tres afloramientos conocidos de saponita en el lado este del Lago Natron, que es un lago salino-alcálico en el norte de Tanzania. Estos depósitos se encuentran a una elevación de 2,000 pies sobre el nivel del mar, más o menos a la latitud de 3°S y unas 534 millas al noroeste de la ciudad y puerto de Dar-es-Salaam. Desde el término ferroviario de Arusha se llega a este yacimiento via 40 millas de carretera pavimentada y 92 millas de camino de tierra casi intransitable, conocido como la "senda de los contrabandistas."

Estos depósitos ocurren en áreas caracterizadas por fuentes termales alcalinas activas. El calor proviene de magma caliente a poca profundidad que alimenta volcanes del *rift valley*. El volcán activo 01 *Doiyo Lengai* se encuentra cerca del extremo sur de Lago Natron y a unas 40 millas al sur del yacimiento. *Mount Gelai* es un volcán inactivo ubicado en el lado este de Lago Natron; la escarpa de *Nguruman* se halla sobre el lado oeste del lago. Entre Lago Natron por un lado y la cima del rift y los volcanes por otro hay una diferencia de nivel de entre 6,000 y 9,000 pies.

La saponita forma un estrato de 3 pies de espesor que en su mayor parte está cubierto por un estrato de magnesita, o por cenizas volcánicas sueltas donde la magnesita ha sido removida por erosión. Previos investigadores identificaron como hectorita a los minerales arcillosos de este depósito. En realidad, el mineral es una saponita muy pura yes de color blanco a blanco pardusco claro casi traslúcido. Se asemeja mucho a cera de vela y, como ésta, es plástica y se deja moldear, de ahí el nombre local de "magnesita plástica." La saponita cruda húmeda tiene casi 40% de agua. La ganga consiste principalmente de magnesita y rodocrosita. Cuando expuesta a los rayos del sol y afire seco en el afloramiento, la saponita rápidamente se seca formando un polvo blanco brillante. Se estima que los depósitos de Gelai tienen una reserva posible de 280,000 toneladas cortas (*short tons*): el depósito norte tiene unas 20,000, el depósito medio 30,000 y el depósito sur 230,000 toneladas.

### Introduction

Over 20 years ago, the late Ben Dickerson, manager of exploration at the company where I was employed, made a statement that I have always remembered. He said "many if not most of the recent major mineral discoveries made by exploration groups were the result of careful literature searches and not reconnaissance geological mapping." Perhaps the best example is the discovery of

the Ertsberg—Grasberg copper—gold deposit on the island of New Guinea (Van Nort et al., 1991). In fact, even the highly productive Bowie, Arizona, chabazite deposit would have been discovered at least two years earlier if a literature search had been done. Oscar Lowe's reference (1975) to the location of an occurrence of chabazite, a zeolite mineral, in the San Simon Valley was published over 84 years before the rediscovery of the deposit in 1959.



The rediscovery of the Mount Gelai hectorite deposit (Fig. 1) is another example of how important a thorough bibliographic search is when exploring for mineral deposits. It is also an example of the high-quality field work done by the British geologists who staffed the Tanganyika Geological Survey prior to the independence of Tanzania, then known as Tanganyika, in 1961. During the trip into the deposit, we used the outcrops the Survey mapped (Guest, 1951; Fig. 2) to determine our location when crossing the extensive area of waist-high grass that often completely obscured the road which was little more than a set of tire tracks along the east side of Lake Natron.

The Mount Gelai hectorite deposit was rediscovered in the literature by G. K. Jones, a British consulting geologist. Jones had learned that the lithium-bearing bentonite (hectorite) was a high unit-value mineral and that most of the world's production came from a single deposit at Hector about 42 mi east of Barstow, California. In 1978 he contacted Mike McGarr, Informational Assistant for the Institution of Mining and Metallurgy in London, requesting references on hectorite localities.

Jones was provided a list of references that included one to the Mount Gelai deposit in Tanzania. In October 1980 he met with William H. Manning at the State Mining Corporation offices in Dar-es-Salaam to discuss the Mount Gelai deposit. On December 15, 1980, Jones wrote a long letter to Manning that described hectorite deposits, processing, markets, and prices for the products. When the State Mining Corporation failed to show any interest in the deposit, Jones wrote an article entitled *The Industrial Minerals of Tanzania* that was published in the July 1981 issue of *Industrial Minerals*. He had never visited the deposit, but in 1982 he acquired samples of the hectorite from the Tanzania Ministry of Energy and Minerals in Dodoma.

The samples he obtained were too small for a thorough evaluation, but the analytical results nevertheless indicated high-purity, white-colored magnesium smectite (saponite). The colloidal fraction of the samples produced poor results. Still, the samples confirmed that saponite

did occur at the deposit and that there was a possibility of hectorite co-occurring at the locality.

Any further interest in the Mount Gelai hectorite deposit was quashed as a result of the unsettled political situation in East Africa at that time. The border between Kenya and Tanzania was closed as a result of the breakup of the East African community. Therefore, there was no road access to the deposit from the Magadi Soda Company operation in Kenya. Further, the Tanzanian economy was moribund as a result of over 20 years of centrally planned, socialist government policies and the war with Uganda. It was apparent that even if a deposit of hectorite were discovered, there was no way to acquire title to it.

In 1988 GSA Resources Inc. (GSA), was contacted by a representative of a company that produced gemstones ("tanzanite") in Tanzania. Tanzanite is a violet-colored variety of scapolite. The chairman of the company wanted to begin producing graphite as a byproduct from their mining operation. The company was interested in other industrial-mineral commodities in Tanzania. In 1989 we were advised by their chairman that the Mount Gelai hectorite deposits on the east side of Lake Natron appeared to be accessible by road from Arusha, Tanzania. Based on this information, we secured funding for the reconnaissance-exploration program and entered into a joint-venture agreement with the Tanzanian company that filed for the necessary Single Prospecting Right and other approvals required from the Senior Principal Geologist and Director of Geology in Dodoma.

In the past the deposit had been accessible only from the Magadi Soda Company in Kenya. There were no roads shown on our maps of Tanzania, therefore our major challenge was to locate a road from Monduli to the east shore of Lake Natron and then find the deposit. It took three days to cover the 132 mi from Arusha to the deposit. The mapping and sampling program required seven days to complete. The return trip to Arusha took two days. An additional four days were spent filling out paperwork at five different government agencies to obtain the permits required to ship the samples to the United States. Clearly, it would have been impossible to have completed the exploration program without the assistance of our Tanzanian joint-venture partner.

#### Location and accessibility

The Mount Gelai hectorite deposits are 534 mi north-west of the capitol and port city of Dar-es-Salaam, Tanzania (Fig. 1). Three deposits crop out along the shoreline on the east side of Lake Natron at an elevation of about 2,000 ft (Fig. 2). The Magadi Soda Company operation in Kenya is about 45 mi north of these deposits. Lake Natron is a saline-alkaline lake that is usually dry except during the rainy season between April and May. The 1990 long rainy season produced the heaviest rainfall on record. As a result, the normally dry salt flats were covered by water and the high water either covered or isolated many outcrops at the middle and south deposits.

During the short periods of time when the deposits were mined for magnesite and bentonite (saponite) the only access was the road from the Magadi Soda Company. This road is now referred to as the "Smugglers Trail" because hides and ivory are smuggled into Kenya and manufactured goods are smuggled into Tanzania along this route. We followed the road northward from the north deposit for about 15 mi toward the Kenyan border and found it very rough but passable by truck.

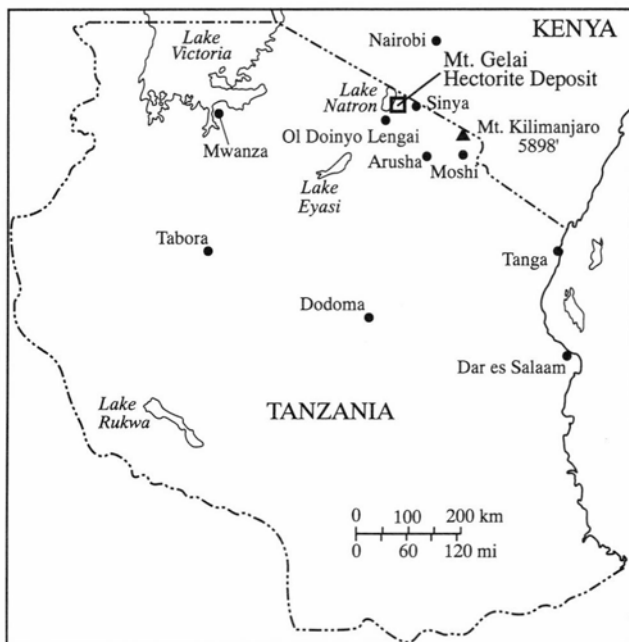

FIGURE 1—Map of Tanzania and neighboring Kenya showing the location of the Mt. Gelai hectorite deposit.

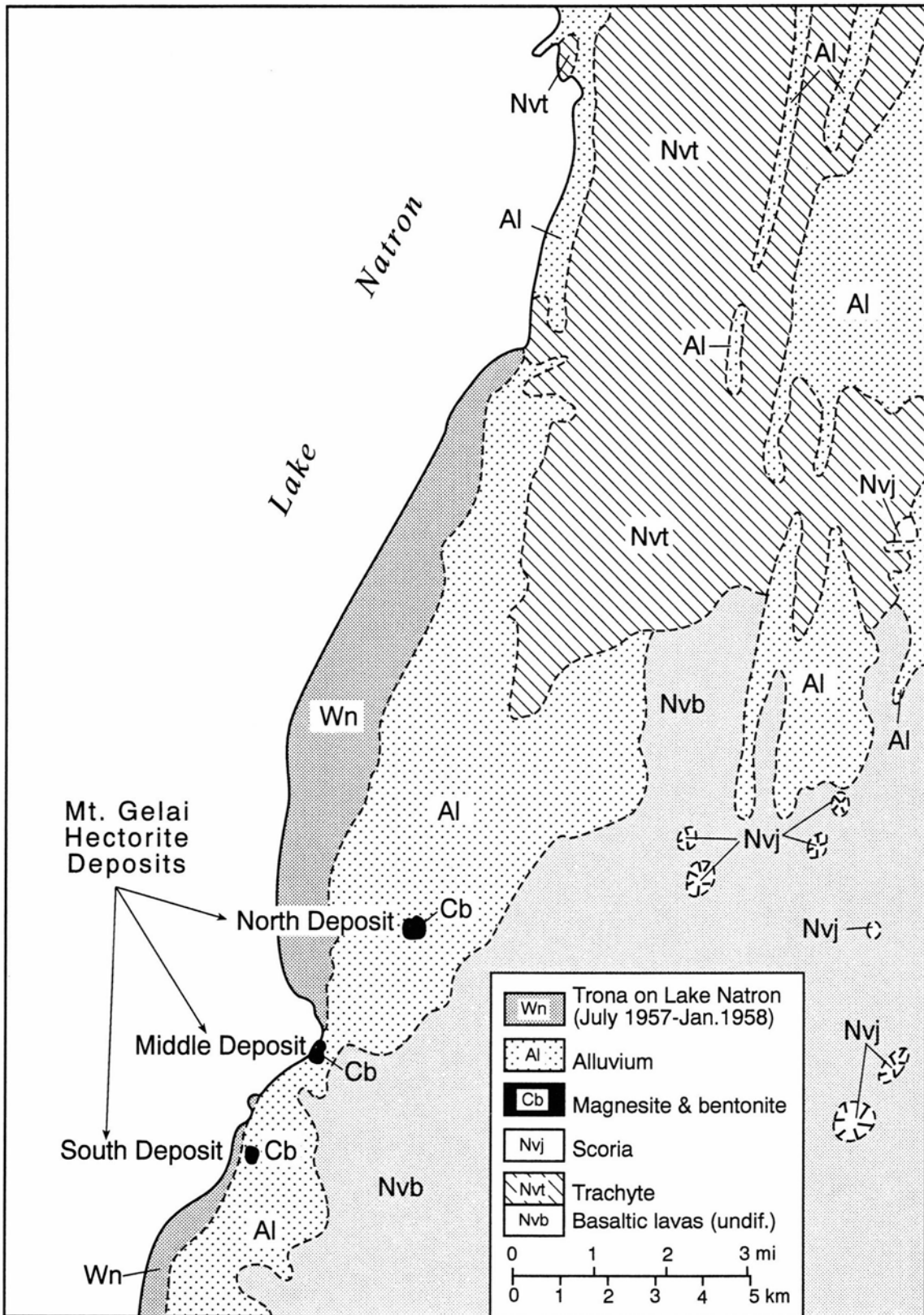

FIGURE 2—Geologic sketch map of the Mt. Gelai hectorite deposits with the north, middle, and south deposits on the east shore of Lake Natron.

In 1976 USAID constructed an all-weather road from Monduli to the south end of Lake Natron. This road, along with several others, was constructed to provide the Masai tribe with access to the arterial highway system so they could ship their livestock to market. Significantly, none

of the roads were never used by the Masai to ship their cattle because the Masai do not sell their cattle. This road remained in relatively good condition until the 1989 rainy season when major stretches of it were obliterated. The "Smugglers Trail" is a track that begins at the Magadi

Soda works in Kenya, crosses into Tanzania where it follows the east shore of Lake Natron, and then crosses mudflats and stream deltas at the south end of the lake and continues southwestward to the Staminco Lake Natron Soda Ash Project.

### Discovery, exploration, and past production

The saponite deposits at Lake Natron were discovered in 1930 by an exploration party from the Magadi Soda Company that identified the magnesite outcrops and reported them to the Tanganyika Geological Survey. Sometime between 1939 and 1945 a road was constructed from Magadi and a few tons of magnesite were mined from the north deposit, which contains the highest-brightness magnesite (Figs. 3, 4). All that remains of the operation is the chassis of a 1942 Dodge truck, a large water-filled pit, and a few stockpiles of magnesite. An elderly Masai man who guided us to the deposit said he worked there, but he had no recollection of the year, though it was probably between 1960 and 1963 when the Tanganyika Meerscham Corporation mined the deposits (Robertson, 1963).

In 1950 N. J. Guest of the Tanganyika Geological Survey examined the north deposit and discovered two similar deposits, the southerly being the largest of the three (Guest, 1951). He called the bentonite found beneath the magnesite "plastic magnesite." but, he did not identify the clay minerals. In 1958 the Tanganyika Geological Survey analyzed chemically one of the bentonite samples and produced its X-ray diffractogram. Although the bento



FIGURE 3—Hectorite pit excavated during the magnesite-mining operation of the north deposit. The top of the saponite bed is at the level of the pick (held by the man standing in water).



FIGURE 4—Hand specimens of saponite from the north deposit. White magnesite is present at the bottom of both samples.

nite contained no lithium, the Survey identified it as hectorite instead of saponite.

Between 1958 and 1960 T. Blevins of Industrial Minerals, the company that controlled the Tanganyika Meerscham Corporation, constructed a permanent road that was traversable by trucks between the north deposit and the Magadi Soda Company in Kenya. Magnesite was mined from the north deposit and saponite from the south deposit. A long, narrow pit (Fig. 5), a section of track, and the remains of a side-dump mine car manufactured in Cardiff, Wales, are the only evidence remaining from the operation that produced saponite for drilling fluids between 1960 and 1963. Incomplete records indicate about 160 st of saponite and 1,000 st of magnesite were produced from the deposits.

The local market for magnesite was limited, and the Mount Gelai magnesite was of inferior quality and as expensive as the imported magnesite used in terrazzo floors. Though the clean saponite component made an acceptable drilling mud, the crude saponite mined from the deposit contained varying quantities of magnesite, rhodochrosite, and other gangue minerals rendering its performance unpredictable. High freight costs to the port made the delivered cost of the Mount Gelai saponite higher than Wyoming bentonite that met API standards.

Robertson (1963) of Resource Use International examined the deposit for the Tanganyika Meerscham Corporation, which was at that time owned by Industrial Minerals, but only a few months later Industrial Minerals and its Tanganyika Meerscham subsidiary were nationalized by the Tanzanian government. Only a few years after nationalization, the blocked-out meerscham reserves at the Sinya deposit (Fig. 1) were depleted and the processing facilities at Sinya were moved to Arusha. Today, the parastatal (state-owned) Tanganyika Meerscham Corporation Ltd. imports all the meerscham used in their pipe manufacturing from Turkey.

### Geology of the Mount Gelai hectorite deposits

The three isolated deposits of saponite identified in this report as the north, middle, and south deposits are all capped by magnesite (Fig. 2). Two other small, partially submerged outcrops of saponite and magnesite were found between the middle and south deposits. At all the deposits the saponite appears to extend well beyond the magnesite outcrops that cap and protect the saponite bed. In fact, many of the auger holes drilled by Robertson indicated that the hectorite bed was continuous across the



FIGURE 5—Looking southwest across the south deposit. Note the remains of truck from the 1960–1963 mining operation beyond the stream on the right.

depressions between the magnesite outcrops. It appears the deposits are more extensive than indicated by the outcrops.

In 1955 N. J. Guest mapped the outcrops and collected several samples of both magnesite and saponite. His maps of the outcrops proved to be sufficiently accurate to use as a base for my sampling. Furthermore, the locations of the auger holes and pits excavated by R. H. S. Robertson in 1962 are also tied to Guest's outcrop maps. This information proved invaluable in defining the lateral extent of the saponite bed.

The north deposit was mined for magnesite at some time between 1939 and 1945 and again between 1960 and 1963. The middle deposit has never been mined; it is about 2 mi southwest of the north deposit. The south deposit was mined for saponite; it is 2.5 mi southwest of the middle deposit. All the deposits are in swampy thermal-spring areas on the east side of Lake Natron.

### **The north deposit**

The north deposit consists of one large semicircular magnesite outcrop about 325 ft in diameter and two small isolated outcrops on the east side of the main outcrop, all underlain by saponite (Fig. 6). At the time of my examination the northwest corner of the outcrop formed part of the shoreline of Lake Natron, although normally it is several miles from the shoreline.

Nine samples were collected, eight from pits and one from a stockpile. In the pits we excavated, the saponite occurs as a flat-lying bed 3 ft thick that is overlain by magnesite or, where the magnesite eroded away, black unconsolidated volcanic ash. The saponite is underlain by a black, arenaceous, bentonite bed. Numerous near-vertical broken or brecciated zones in the magnesite have interstitial spaces filled with saponite.

The saponite is so damp and soft that it can be squeezed and molded by hand much like pottery clay. It was this unique plastic property that caused Guest to refer to it as plastic magnesite; the waxy and translucent saponite resembles candle wax.

Because of the high water level in Lake Natron, all the pits filled with water to a depth of about 3 ft below the pit surface. As soon as the more permeable underlying bentonite was intersected, water flowed into pits faster than it could be bailed out. The alkaline water was hot and had a pH of 10, so it was irritating to the skin.

The auger holes drilled by Robertson and the pits excavated by both of us (Fig. 6) indicate that the saponite bed ranges from approximately 1 to 7 ft and averages nearly 3.5 ft thick. The saponite extends at least 200 ft beyond the magnesite capping to the northwest, where auger holes A-1 and A-7 both intersected saponite.

Based on the pits I excavated, the auger holes drilled and pits excavated by Robertson, and assuming continuity of the saponite bed, the north deposit contains a possible reserve of about 20,000 st of crude wet saponite. It is reasonable to assume that moisture and nonclay components constitute at least 50% of the crude saponite. Therefore, the reserve amounts to about 10,000 st of processed product.

### **The middle deposit**

The middle deposit is on the shore of Lake Natron about 2 mi southwest of the north deposit. It consists of 11 outcrops in the central part of the deposit (Fig. 7). Another deposit about 0.5 mi to the north (off the map) was sub-

merged in Lake Natron and could not be sampled. About 1 mi south of the main outcrops are three small, partially submerged outcrops. I was able to collect two samples from these outcrops.

Fortunately, Lake Natron had receded significantly otherwise all the outcrops of the middle deposit would have been either submerged or have been islands in the lake. It was possible to collect 11 samples of the saponite that crops out on the periphery of the magnesite outcrops.

The saponite bed intersected by the 11 pits we excavated was flat-lying and had an average thickness of slightly less than 2.5 ft. It is underlain by a black, arenaceous bentonite. The color of this bed results from a high percentage of unaltered and partially altered fragments of basalt and basaltic ash intercalated with the bentonite. Unlike the overlying magnesite bed at the north deposit, the overlying magnesite at the middle deposit is brown and does not appear to contain the vertical brecciated zones with saponite-filled interstitial spaces.

As at the north and south deposits, the saponite is damp, soft, and translucent. It ranges from brownish-black to white and has a waxy luster. Generally, the saponite from the middle deposit is darker than saponite from the other two deposits. Also, more thermal springs are present in the middle deposit. Because of the springs and the high water level in Lake Natron, several of the pits we excavated filled with hot water before we could sample the full thickness of the saponite bed. Therefore, the bed is somewhat thicker than that portion of the bed that actually could be sampled.

Based on the auger holes drilled by Robertson and the pits excavated by both of us, the saponite bed ranges from 1 to 11 ft and averages over 3.5 ft in thickness. This is comparable with the thickness of both the north and south deposits. The saponite appears to extend to the northwest beyond auger hole A—C4. To the south, the saponite bed appears to terminate between the last outcrop and pits P—C1 and P—C2. These pits, which Robertson indicated filled almost immediately with hot water, may not have been deep enough to have intersected the bed.

Based on the pits I excavated, the auger holes drilled and pits excavated by Robertson, and assuming continuity of the saponite bed, the middle deposit contains a possible reserve of about 25,000 st. Including the 5,000 st of possible reserves in the deposit 1.5 mi to the south, the middle deposit contains a possible reserve of 30,000 st of crude wet saponite. Assuming that the moisture and nonclay components constitute at least 50% of the crude saponite, the reserve amounts to about 15,000 st of product.

### **The south deposit**

The south deposit is on the shore of Lake Natron about 2.5 mi southwest of the middle deposit. It consists of eight large and two small outcrops (Fig. 8). About 160 st of saponite were mined from a pit in the northern part of the deposit by the Tanganyika Meerschaum Corporation in 1962. At the time of my examination, four large outcrops and one of the small outcrops were completely surrounded by water. Normally the deposit is several miles away from the shoreline.

Because the south deposit is much larger than the north and middle deposits combined, it was necessary to reduce the scale of the outcrop and sample-location map (Fig. 8) from 1:1,250 (1 inch = 104 ft) to 1:2,500 (1 inch = 208 ft). To put this into perspective, the area covered by

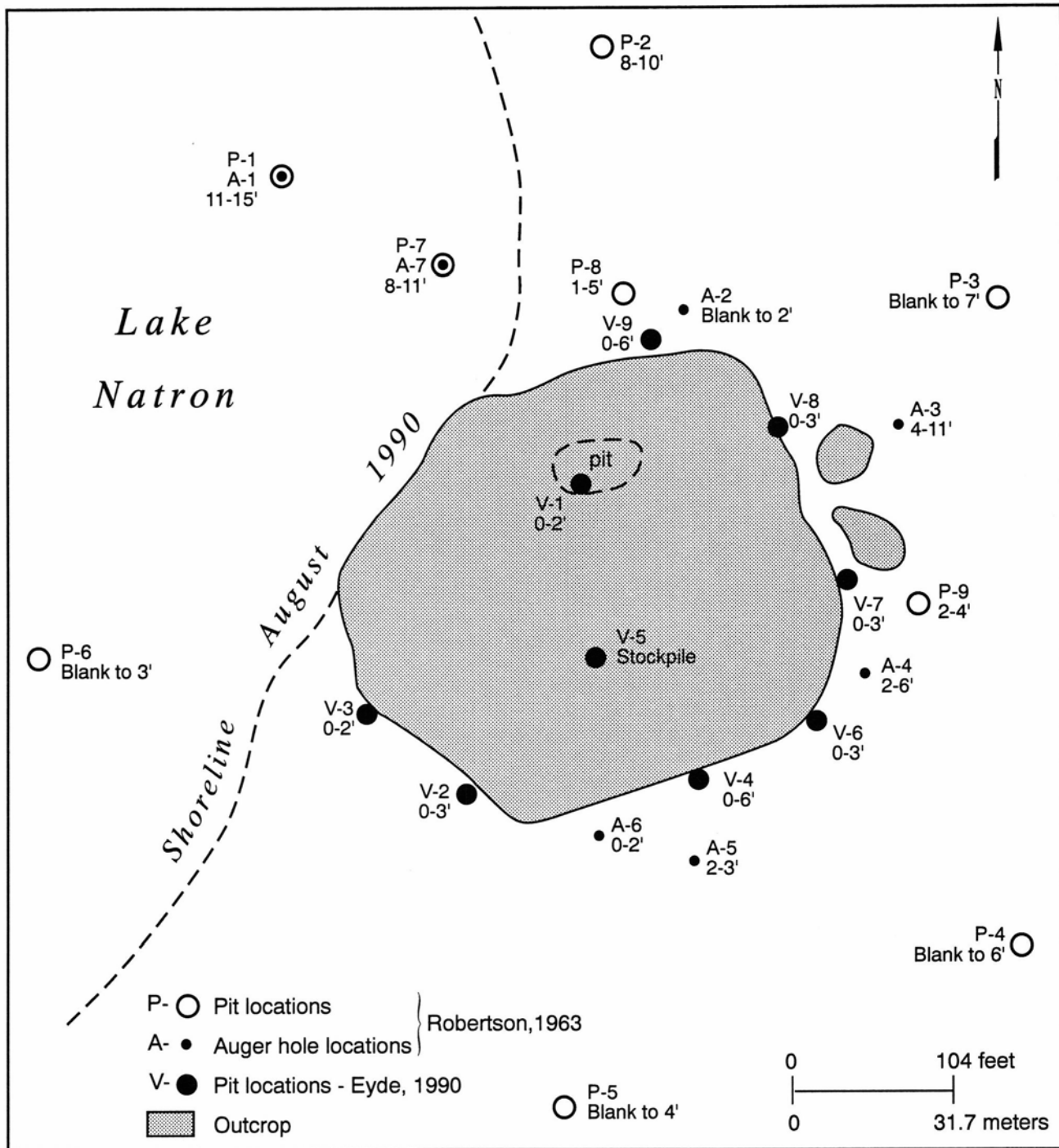

FIGURE 6—Outcrop and sample location map of the north deposit. Outcrop map after Guest (1955). Samples from pits (Robertson, 1963; Eyde, unpubl. data 1990) and auger holes (Robertson, 1963). Numbers (in feet) indicate depth to saponite and the bottom of the pit or auger hole. Saponite may be thicker than the interval. As, 8–10' indicates a saponite bed at least 2 ft thick was first intersected 8 ft below the surface.

the map of the south deposit is four times as large as the area covered by either the north or middle deposits.

In the pits we excavated, the saponite occurs in a flat-lying bed slightly less than 3 ft thick (Fig. 9). It is underlain by the same black arenaceous bentonite bed that occurs at the other two deposits. The saponite bed is overlain by brown magnesite similar to that at the middle deposit (Figs. 10, 11). Breccia zones with saponite-filled interstitial spaces do not appear to occur at this deposit.

The saponite is damp and soft. Most of the samples collected at this deposit were light, brownish-white color,

whereas samples 32 through 36 from pits V-32 to V-36 (Fig. 8) were nearly white. This suggests that the east-central part of the deposit is whiter than the northern part. The saponite from the latter area is waxy, translucent, and resembles candle wax.

As was the situation at the north and middle deposits, all of the pits quickly filled with water when the base of the saponite bed was penetrated. This deposit is also located in an area of thermal springs (Fig. 12), therefore the water that filled the pits was hot and highly alkaline.

The auger holes drilled by Robertson and the pits ex-

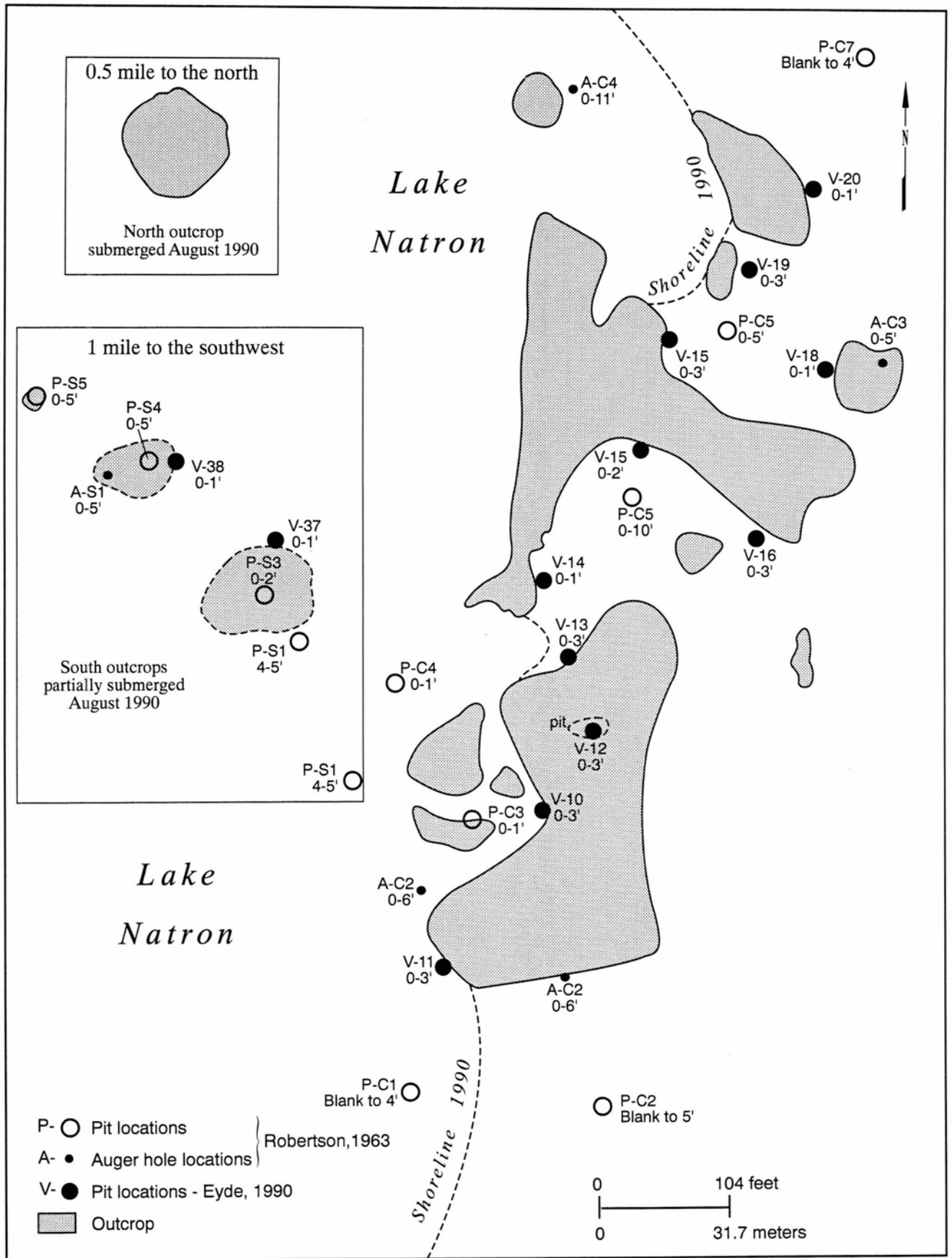

FIGURE 7—Outcrop and sample location map of the middle deposit. Insets of north and south outcrops submerged or partly submerged in 1990 lie 0.5 mi north and 1 mi southwest, respectively, off rest of the map. Outcrop map after Guest (1955). Samples from pits (Robertson, 1963; Eyde, unpubl. data 1990) and auger holes (Robertson, 1963).



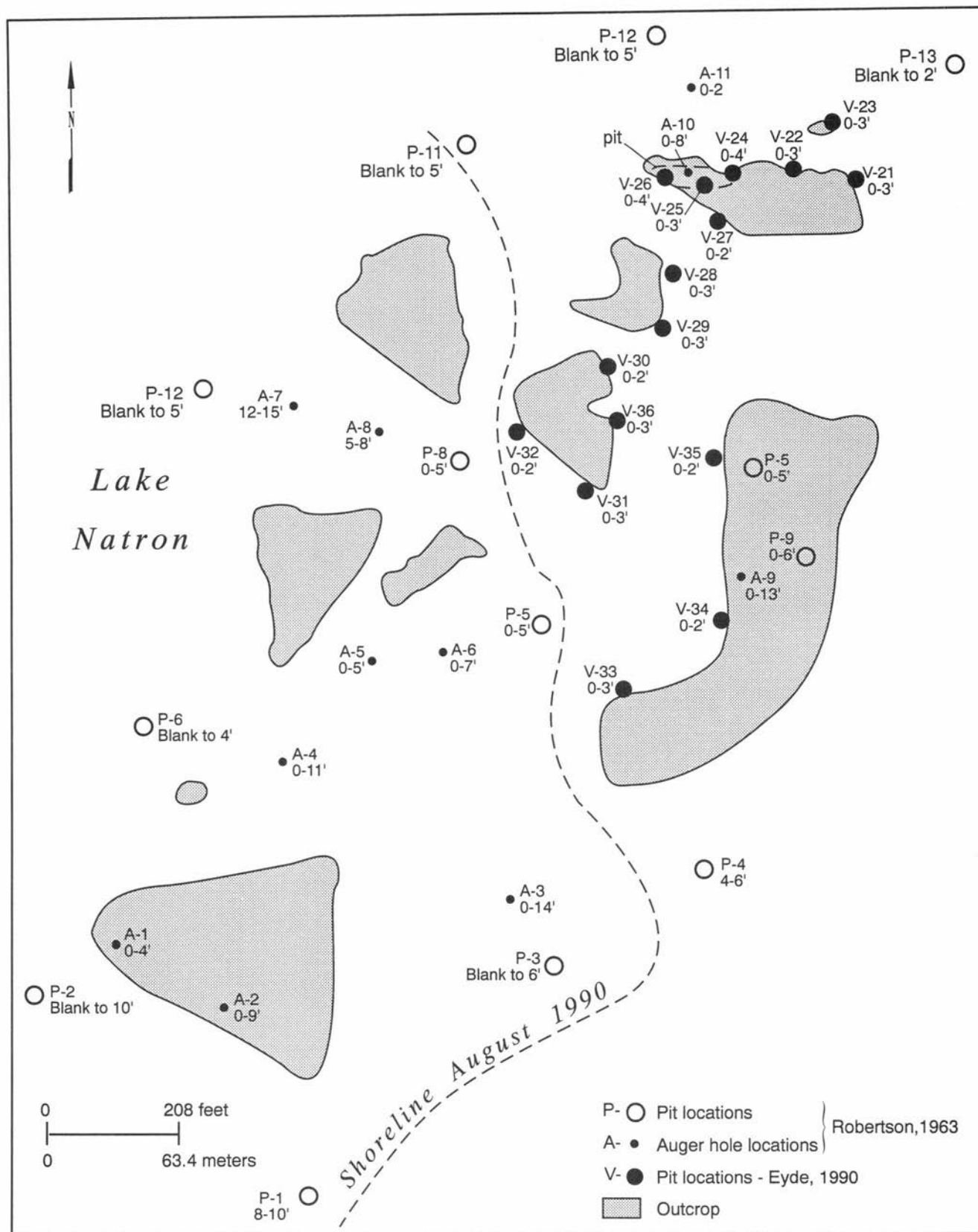

FIGURE 8—Outcrop and sample location map of the south deposit. Note that scale is not the same as in Figures 6 and 7.

cavated by both of us indicate that the saponite bed ranges from approximately 2 to over 14 ft and averages 4.5 ft thick. The pits Robertson dug around the periphery of the deposit suggest that the limits of the deposit to the north, south, and west may have been located. The deposit may continue to the east beyond the exposure area.

From the results of the test pits at the north deposit it appears that many pits in the south deposit were not deep enough to intersect the saponite.

Based on the pits I excavated and the auger holes and pits excavated by Robertson, and assuming continuity of the saponite bed, the south deposit contains a possible





FIGURE 9—Excavating a pit in the saponite bed at the south deposit.

reserve of about 230,000 st of crude wet saponite. Assuming that the moisture and nonclay components constitute at least 50% of the crude saponite, the reserve amounts to about 115,000 st of product.

**Genesis of the hectorite and saponite deposits** The Mount Gelai hectorite deposits conform to the model GSA developed to assist in the exploration for sa



FIGURE 10—Sampling the saponite bed beneath the magnesite cap. A swampy thermal-spring area is in the foreground to the right.



FIGURE 11—A pit excavated in the saponite bed at the south deposit. Note the magnesite outcrop to the left and behind the worker and the vegetated swampy area to the left.

ponite and hectorite deposits in the southwestern United States. We recognized that deposits of saponite and hectorite were genetically related to Cenozoic to Recent volcanism. Volcanism, along rifts in the earth's crust produces the source rocks, heat, and hydrothermal solutions needed to form the hectorite and saponite deposits.

The deposits GSA explored in the southwestern United States are often localized along linear travertine-filled fissures. We believe that thermal springs moved hydrothermal solutions containing magnesium, sodium, lithium, and other elements along the fissures and diffused them outward into the enclosing ash and clay beds. Magnesium replaced aluminum in the smectite. If the solutions contained excess sodium, calcium in the smectite was also replaced.

At deposits GSA explored in the United States, the thermal-spring systems that were responsible for the formation of hectorite and saponite are no longer active. All that remains are their travertine-filled conduits. These occur in the deposits of hectorite and saponite at Hector, California; Invite, Nevada; and Lyles and Burro Creek, Arizona.

It was therefore interesting to see the Mount Gelai hectorite deposits that occur in a rift valley associated with active volcanism and thermal springs. All the deposits are within areas that contain numerous active thermal springs. The saponite bed appears to have been a layer of vitric ash that has and perhaps still is undergoing alteration. Magnesite, which caps the deposits, has protected them from complete removal by erosional pro-



FIGURE 12—Very hot thermal springs at the Mt. Gelai hectorite deposits.

cesses. These deposits confirm that the exploration model GSA developed to locate hectorite and saponite is valid.

#### References

- Guest, N. J., 1951, Gelai magnesite: Geological Survey of Tanganyika, Mineral Resource Pamphlet 52, 12 pp.
- Jones, J. K., 1981, The industrial minerals of Tanzania: Industrial Minerals, no. 166, pp. 23-29.
- Lowe, O., 1875, Report upon mineralogical, agricultural, and chemical conditions observed in portions of Colorado, New Mexico, and Arizona in 1873: U.S. Geographical and Geological Exploration and Surveys West of the 100th meridian (Wheeler), pt. 6, v. 3, pp. 559-661.
- Robertson, R. H. S., 1963, The Gelai bentonite deposits: Unpublished report Resource Use Limited for the Tanganyika Meerscham Company, 62 pp.
- Van Nort, S. D., Atwood, G. W., Collinson, D. C., Flint, D. C., and Potter, D. R., 1991, Geology and mineralization of the Grasberg porphyry copper-gold deposit, Irian Jaya, Indonesia: Mining Engineering, v. 43, pp. 300-303.

# Cat litter—A growing market for industrial minerals

George S. Austin<sup>1</sup> and Cynthia Mojtabai<sup>2</sup>

<sup>1</sup>New Mexico Bureau of Mines & Mineral Resources, New Mexico Tech, 801 Leroy Place, Socorro, New Mexico 87801-4796, USA

<sup>2</sup>School of Law, University of New Mexico, Albuquerque, New Mexico 87131, USA

**Abstract**—Cat litter is shipped worldwide and, at about \$2.00 for a 10 lb bag, is sold at about \$880 /mt. In the United Kingdom alone, the cat litter market has risen to an annual value of £43 -45 million, 90% of which is dominated by absorbent clays such as bentonite, fuller's earth, sepiolite, and attapulgite or palygorskite. Other non-clay mineral materials include zeolites, hydrated calcium silicates, and gypsum-based litters. Non-mineral cat litters include crushed peanut shells, alfalfa pellets, waste-paper pellets, and literally anything else. In the United States, heavyweight clay (HWC) cat litter includes the Porters Creek Clay in the Mississippi Embayment, dominantly composed of Ca-smectite and opal CT. Other clay minerals include illite, kaolinite, and lesser amounts of palygorskite/attapulgite. The latter is a lightweight clay (LWC) mineral used as the primary ingredient in some cat litters. Sepiolite is another lightweight clay mineral. Most scoopable clay litter is composed primarily of Na-smectite (montmorillonite) and comes from Wyoming. A scoopable cat litter from Georgia contains mixed montmorillonite and palygorskite/attapulgite. Zeolites, particularly clinoptilolite, occupy a small niche in the market and are produced in Texas and southern New Mexico.

Although marketing plays a large role, to be successful the product must control odor. Other important properties include absorbency, bulk density, granule size, dust formation, longevity, strength, and color. New trends include litters that are lighter weight and those that last longer, such as the scoopable types.

In 1992, there were approximately 63 million cats in the United States and the number continues to rise. The annual volume of cat litter in Europe is 1,000,000 mt and the popularity of a premium product, such as scoopable cat litter, is expected to increase. Introduced about 1988, scoopable cat litter now accounts for about 30% of the market in the United States. As cities increase in population, the number of cat owners who purchase litter is expected to rise, increasing sales. With sales increasing in spite of high prices and a relatively low amount of government intervention, the cat-litter industry has a promising future.

## Gránulos higiénicos para gatos—un mercado creciente para minerales industriales

**Resumen**—Los gránulos higiénicos para gatos (*cat litter*) se venden en todo el mundo. Con un precio de casi dos Mares por una bolsa de 10 libras, vale unos \$880.00 por tonelada métrica. Tan solo en el Reino Unido, el mercado de gránulos para gatos asciende a un valor anual de 43 a 45 millones de libras esterlinas; el 90% de esto consiste de arcillas absorbentes, tales como: bentonita, arcilla absorbente (*fuller's earth*), sepiolita, y attapulgita o palygorskita. Minerales no arcillosos que se usan para hacer gránulos son: zeolitas, silicatos hidratados de calcio, yeso. Gránulos de tipo no-mineral consisten de cascara molida de mani (cacahuete), granulos de alfalfa o de papel usado y otros materiales varios. En los E.U.A. gránulos hechos de arcilla pesada (HWC), se fabrican de las *Arcillas de Porters Creek* que forman parte estratigráfica del Golfo Missisipiense y están compuestas principalmente de smectita de calcio y *opal CT* (cristobalita hidratada, criptocristalina). Otros minerales para este uso son illita, caolinita y cantidades menores de palygorskita/attapulgita. Esta arcilla es una arcilla liviana usada como ingrediente principal en algunos tipos de granulos. Sepiolita es otro mineral liviano. El ingrediente principal en la mayoría de los granulos depurables es una smectita sódica (montmorillonita) que viene de Wyoming. Otro tipo de granulo depurable viene de Georgia y contiene una mezcla de montmorillonita y palygorskita/attapulgita. Las zeolitas, en particular la clinoptilolita, llenan una pequeña parte de este mercado y se producen en Texas y el sur de Nuevo Mexico.

Aunque la comercialización es un factor muy importante, para tener la aceptación del público el material debe suprimir el olor. Otras propiedades importantes son la absorbencia, la densidad, el tamaño de grano, la ausencia de polvo fino, la longevidad en el uso, la friabilidad, el color. Nuevas calidades son: gránulos mas livianos y variedades mas durables, tales como tipos que pueden ser depurados.

En los E.U.A., en 1992, había unos 63 millones de gatos y el número va en aumento. En Europa, el volumen anual de gránulos higiénicos para gatos es de un millón de toneladas métricas y hay indicaciones que la popularidad de este producto este creciendo, especialmente las variedades depurables. Introducidas en 1988, los granulos depurables actualmente forman un 30% del mercado en los E.U.A. Con las poblaciones urbanas en continuo aumento, es dable esperar que la demanda por este producto tambien crezca. Con las ventas en aumento, a pesar de altos precios, y controles gubernamentales relativamente moderados, la industria de los gránulos higiénicos para gatos presenta un futuro promisorio.

## Introduction

While cat litter is not one of the glamorous industrial-mineral commodities, it is one of the most market-sensitive and valuable. At \$2.00 for a 10 lb bag of cat litter, sodium bentonite (Na-bentonite) has a *retail* value of about \$880 /metric ton (mt), commanding at least 20 times a higher price than carload lots of foundry-grade Wyoming bentonite *FOB plant* at \$33-44/mt (Anonymous, 1995). Furthermore, cat litter is shipped to all continents, and the international market is expected to increase. In the United Kingdom (UK) alone, the cat litter market has risen to an annual value of £43-45 million (O'Driscoll, 1992), 90% of which is dominated by absorbent clays such as bentonite, fuller's earth, sepiolite, and palygorskite/ attapulgite (Santarén, 1993).

The cat-litter market is highly competitive with producers of other cat-litter materials constantly trying to fit their product into the market. Many larger producers have extensive testing facilities and constantly try to improve their products to bring out new "improved" varieties. Some litter blends are often highly proprietary and some are even patented (O'Driscoll, 1992).

### Mineral cat-litter materials

#### Heavyweight clays (HWC)

The heavyweight clays include fuller's earth and Na-bentonite and range in density from 800 to 980 kg /m<sup>2</sup> (O'Driscoll, 1992). While HWC's densities are around 50% more absorbent than that of lightweight clays and are rather abundant, they are also 50-80% heavier and thus are declining in use.

Fuller's earth is a term that comes from its original use in absorbing contaminants from natural wool. In the United States, it is a use-oriented term for clay material that contains Ca-bentonite, acid-activated illite, and palygorskite/attapulgite. In Europe, fuller's earth is composed primarily of Ca-bentonite. The UK has fuller's earth deposits that have been mined since the time of the Romans; hence, it is a readily available and popular cat litter there (O'Driscoll, 1992).

Bentonite is composed mainly of smectite clay minerals, most commonly montmorillonite; depending on the exchangeable cation present, it can be swelling or non-swelling. The swelling form is the Na-bentonite (Na-smectite, Western bentonite, or Wyoming bentonite), whereas the Ca-bentonite (southern bentonite) is the poorly swelling to non-swelling form. Na-bentonite has a new place in the cat-litter market as clumping or scoopable litter. Clumping-litter producers also incorporate other types of materials into their particular blend, including fuller's earth and zeolites.

#### Lightweight clays (LWC)

The lightweight clays include sepiolite, palygorskite/attapulgite, and "moler" from Denmark, and range in density from 400 to 700 kg/m<sup>3</sup>. LWCs account for 70% of the European cat-litter market (O'Driscoll, 1992).

Although sepiolite and palygorskite (members of the hormite clay-mineral group) may take a variety of macroscopic forms from massive to fibrous, they invariably are lath-like or fibrous on a microscopic scale. They both are hydrated magnesium—aluminum silicates composed of tetrahedral and octahedral layers similar to other clay minerals. Unlike mica-like (phyllosilicate) clay minerals with continuous layers in two dimensions, palygorskite and sepiolite have this continuity only in one dimension,

and the resulting laths are separated by zeolitic pore spaces. The ribbons are composed of three linked pyroxene-like chains in sepiolite and two linked chains in palygorskite. Palygorskite (Fersman, 1913) is the preferred name because of its introduction into the literature before the term "attapulgite" by DeLapparent (1935). Bradley (1940) determined that palygorskite and attapulgite were both structurally and chemically the same mineral, but "attapulgite" has persisted because some authorities maintain that there is a morphological difference between the two. Some non-fibrous clay minerals found in southern Georgia and northern Florida are identified as attapulgite. Both names are used (palygorskite/attapulgite) in this paper, but this is not meant to imply that the two are mixed minerals.

Sepiolite and palygorskite/attapulgite are relatively rare and are both mined in Spain and the United States. Most of the sepiolite from Spain is used for cat litter. In 1983, 31.3% of the palygorskite/attapulgite sold in the United States or exported (the largest percentage for any one use) was used for cat litter (Clarke, 1985). In 1991, the Floridin Company, a subsidiary of U.S. Silica Company (ultimately RTZ Corporation), Engelhard Corporation, and Oil-Dri Corporation mined hormite clays in Georgia and Florida with some tonnages from all companies going into the cat-litter market (Russell, 1991).

Moler clay is a type of diatomaceous earth composed of 23% montmorillonite clay, 2% volcanic ash, and 75% diatomaceous earth (amorphous silica). It is the only litter product that is calcined at high temperature. For the past 80 years moler has been quarried in northwestern Denmark, the only place where it is commercially produced (O'Driscoll, 1992).

#### Non-clays

Several cat-litter products are non-clays. Only those that are inorganic or derived from an industrial mineral are discussed here. The main non-clay-mineral materials used for cat litter are zeolites (particularly clinoptilolite), hydrated calcium silicates, and gypsum.

In 1991, Nonscents Co. of Houston, Texas, began marketing zeolites in London, U.K., as an odor fighter against smells such as cigarette smoke and ammonia (Anonymous, 1991). Indeed, zeolites are aluminosilicates with the very large surface area necessary for absorption and odor control, up to 60 m<sup>2</sup> per gram (S. Peterson, Zeotech Corporation, oral comm. 1993). Despite their advantageous properties, zeolites as the only or major ingredient in cat litter still form but a small part of the litter market, and their sales are regionalized. However, clinoptilolite is an additive in many other cat litters and may account for from 10 to 30% of the product weight. The principal benefit is in odor control, but it is also beneficial as a fragrance carrier (P. S. Freeman, St. Cloud Mining Company, written comm. 1995). Shaker bottles of sized clinoptilolite for cat-box deodorizing are sold in many pet stores.

Hydrated calcium silicate is a premium product in Europe, especially Germany, where white-color and low-density (380-420 kg/m<sup>3</sup>) litter is preferred. In essence, it is the product of lime and silica after hydration, much like what goes into cement and bricks. The exact process and formula used for cat litter is a trade secret guarded by its few manufacturers (O'Driscoll, 1992).

Gypsum-based cat litter is marketed chiefly by Oil-Dri Corporation that has patented the process. Plaster of Paris is rehydrated, dried, and crushed using certain steps and specifications, resulting in the granular absorbent mate-

rial. The end product is also a white, lightweight, premium product marketed mainly in Europe.

### Material characteristics

Beyond odor control, the properties of the material destined for use as cat litter are far less important in sales performance than marketing. In general, if the material is relatively absorbent, dense enough to stay in the litter box, has a large and round enough granule that will not stick to or cut the cat's paw, and looks nice on the shelf, it is a saleable product.

Specifications are becoming more important, which is particularly true of the European market (Table 1). However, companies do not actively explore for cat-litter deposits, they try to market what is readily available to them. Materials that have the most advantageous properties are simply better products and thus in some ways easier to market (O'Driscoll, 1992).

### Absorption

Absorption is the penetration of a substance into the body of another, generally that of a fluid into the body of a solid (Table 2). Capillary action usually drives absorption in a solid which must be porous and permeable, with a large surface area (Santarén, 1993). The term adsorption signifies certain interactions between fluid molecules and the solid surface. Adsorption is due to attractive forces between the fluid and solid surfaces, and can be an important part of absorption processes. Particle-size distribution is important in the absorbency of a material, because the finer it is ground, the larger the surface area per volume becomes.

Materials that contain micropores, a capillary structure, or some type of solid-to-fluid interaction also have enhanced absorption. Some types of clay minerals (e.g. smectite) can absorb fluid on the external surfaces and in interlayer space, which results in swelling. Sepiolite, palygorskite/attapulgite, and zeolites absorb fluid on external surfaces and zeolitic channels, but they do not allow swelling when absorbing fluid. The fluid itself also plays a large part in the absorption process. The fluid's density, viscosity, and surface tension are important properties that determine the capillary suction by clay granules. When adsorption mechanisms are involved, volume, polarity, and molecular shape all are important in determining how much will be absorbed into the solid (Santarén, 1993).

### Bulk density

Bulk density is a property of concern in marketing rather than in product quality. However, if the bulk den-

sity is too low, the filler will leave the litter box with the cat, and if the bulk density is too high, a reasonably thick bed (and bag) will be heavy. Marketing strategy depends on the particular product. Producers of high-bulk-density litter stress the "space-saving" aspects of their product, whereas low-density litter producers stress the value in price-per-volume terms. A clever marketing strategist can turn any bulk density into an asset; for example, a 20 lb bag of high bulk-density material may appeal to the "bulk" shopper, while a 2 gallon jug of lightweight material may attract the more selective shopper. It is wise to remember that the litter box is a volume to be filled, and the lighter-weight material is more convenient for the person filling that box.

### Granule size

The litter granules must be large enough not to stick to the cat's paws. This size requirement offsets the smaller size's higher absorption beneficial effect and a balance must be sought. In general, the preferred granule size range is from 1 to 6 mm (O'Driscoll, 1992). In the United States, granule sizes of most conventional cat litters range from 0.5 to 3 mm, while those of clumping litters range from 0.5 to 1.5 mm (P. S. Freeman, St. Cloud Mining Company, written comm. 1995). The shape of the granule must also be as rounded as possible in order not to injure the cat or get trapped in the cat's paw or attached to its fur. Angular granules might also rip a paper package.

### Odor control

The control of odor is, of course, a necessary property for any litter material. The primary goal is retarding the fermentation of urea to ammonia. This property is related to the surface characteristics of the material. Smectite and palygorskite/attapulgite perform very well. Zeolites absorb ammonia after its formation, but the longevity of this property for zeolite litters is in question. Granule size and bulk density also play a part in odor control. The smaller the particle size, the better the material seals the animal waste, provided the density is high enough to keep the material in place.

### Formation of dust

While probably not significant to the cat, to pet owners a dusty cat litter ranks in the same disagreeable domain as does a litter that does not absorb odors. The litter should be dust-free and the granules should have adequate mechanical strength to prevent the formation of dust during shipping and handling and when the litter is placed in the litter box.

TABLE 1—Specifications of various European cat litters. Source: O'Driscoll, 1992.

Cat-litter material	Color	Bulk density (kg/m <sup>3</sup> )	Absorbency (wt % <sup>a</sup> )	Granule size (mm)
Fuller's earth, UK	Golden	810	120	1.0–6.7
Fuller's earth, Mediterranean	Light gray	980	130	1.8–5.6
Fuller's earth blend, Germany	Medium gray	1,000	50	2.0–4.0
Attapulgite, Senegal	White	600–650	80–100	1.0–6.0
Sepiolite, Spain	White	500–715	75–95	0.25–6.3
Moler (calcined), Denmark	Pink	400–600	60–100	1.0–6.0
Synthetic calcium silicate	Very white	380–420	100–140	1.6–8.0
Wood-based (softwood flour), UK	White	500–600	150–350	20 <sup>b</sup>

<sup>a</sup>Westinghouse Absorption defined as volume of water absorbed by weight of product. This value tends to increase as the granule size decreases. Other methods used include the modified BASF method. <sup>b</sup>Pellets.

TABLE 2—Zeotech Corporation preliminary test results of absorptive properties of selected American non-blend pet litters. Source: Zeotech Corporation, 1984 (received in 1993)

Product name	Sample producer	Volume (cc)	Water absorption weight (gm)	Water absorption capacity (wt.%)	Ammonia absorption capacity (vol.%)	Capacity (meq/100g)	Observations
<b>Heavyweight clay (HWC)</b> Tidy Cat	Golden Cat Co.	100	73.5	61	45	24	Mild detergent smell, saturates to a dark gray mush
Kitty Litter	Golden Cat Co.	100	70.0	63	44	38	Dusty product, saturates to a dark gray mush
Fresh Step	Clorox Co.	100	60.1	78	47	22	Cream-colored particles, detergent smell
Generic cat litter	Topco	100	71.2	71	51	31	Dusty; abundant fine particles, saturates to dark gray mush
<b>Lightweight clay (LWC)</b> Control	Clorox Co.	100	60.1	78	47	26	Cream-colored particles, chemical smell
Cat's Pride	Oil-Dri Corp.	100	68.2	64	44	31	Dusty product, saturates to a dark gray mush
<b>Zeolite</b> Kitty Crystals	Zeotech Corp.	100	75.3	68	51	109	White color, good particle strength when wet
<b>Organic-base (alfalfa)</b> Litter Green	McFadden Co.	100	64.6	74	48	—	Alfalfa pellets, swell and decompose when wet

### Longevity

How often a litter box needs to be changed is of much concern to the consumer. For instance, if the litter needs changing after every use by the feline, then a person might as well use beach sand rather than a high-priced box filler. To withstand long-term use in the litter box, the litter must be relatively strong, must be able to cover the waste well, and must be able to control offending odors for a reasonable length of time. Producers of the new type of "scoopable" cat litter stress the longevity aspect of their product; by scooping out the encapsulated waste, the pet owner never actually needs to change the litter box and less litter is used in the process.

### Strength

Although longevity depends somewhat on the strength of the material (e.g. an extremely weak litter will not withstand much cat traffic), the strength of the litter is a concern mainly because of dust content. Dust is a problem to those who handle the litter, and it is also a concern for the safety of the animal. The amount of respirable silica dust contained in any material considered for use as cat litter should be kept to a minimum. In 1988 the West German Consumer Council found microscopic asbestos-like fibers in seven cat litter products, but later the former West German Federal Health Office found the litters harmless. This scare proved that, with a commodity driven by markets, a producer cannot afford health risks that are either real or perceived (O'Driscoll, 1992).

### Color

Color does not affect performance, but since cat litter is strongly affected by marketing and consumer preference, color can seriously impact sales of a particular litter. Germans, and generally all Europeans, prefer light-colored litter; Danish molar cat litter is pink. However, the preferred litter color in the UK is gray (O'Driscoll, 1992). The whiter the litter, the more "antiseptic" its appearance might seem to a consumer (Table 1). In the United States, light-colored cat litters are popular also with veterinarians, who find them helpful in detecting feline health problems such as urinary infections.

One cat litter produced in the United States features a small portion of blue-dyed clinoptilolite granules with the rest of white clinoptilolite granules. To the consumer, the product appears to contain a certain portion of blue "power crystals" that will enhance performance. In fact, the dyed granules may be less permeable and thus less able to remove liquids and odors.

### Disposal methods

Most of the two basic types of cat litter are disposed of with the rest of the household trash, but "flushable" litters are being introduced. Some manufacturers, such as a producer in New Mexico (P. S. Freeman, St. Cloud Mining Company, oral comm. 1993), strongly recommend that no litter be flushed. Indeed, some communities have regulations prohibiting the disposal of animal waste in the sewage system. Yet some manufacturers, whose product contains no swelling clay and only chain-structure clay minerals such as sepiolite and attapulgite, claim that their product is safe to be flushed and stress this aspect of convenience.

### Markets and market trends

The cat-litter market is one of the most stable of the industrial-mineral markets, and is actually on the rise at

a rate of 6% annually (Santarén, 1993). As city populations increase, the pet of choice will increasingly be an indoor cat. It also follows that as apartment sizes decrease, the litters of choice will be the lighter, higher premium products which can last a much longer time, such as the new scoopable-type litter. Sales of cat litter also are the highest during winter months and in larger northern metropolitan areas, reflecting its use by house-bound cats (P. S. Freeman, St. Cloud Mining Company, written comm. 1995).

Table 3 shows the estimated U.S. consumption of absorbent clays through time, and Table 4 shows the consumption for 1993. More recent information from the U.S. Bureau of Mines indicates that the demand for cat litter is dramatically increasing. In 1993 (Table 4) the demand for cat litter exceeded the prediction for 1996, made in 1992 (Table 3). In 1992 consumption of fullers' earth for cat litter was 1.4 million mt, while consumption of bentonite for the same purpose was 148,000 mt (Robert L. Virta, U.S. Bureau of Mines, oral comm. 1995). In 1993, for the same purpose, fullers' earth consumption was 1.5 mt, while bentonite was 300,000 mt. Other cat litters, including zeolites, hydrated calcium silicates, calcined gypsum, and hormites (sepiolite and palygorskite/ attapulgite), as well as organic products such as peanut shells and alfalfa and waste-paper pellets, together make up about 10 to 20% of the U.S. market.

### Packaging

The attractiveness of a cat-litter product on the supermarket shelf is perhaps the most important aspect in terms of sales. The litter product must look neat, clean, sanitary, and be convenient to handle. Some generic or "budget" products use large low-grade paper bags that enhance the economic image of the litter product. Other producers, who choose to market a more specialized product, have gone to attractive plastic jugs giving a more antiseptic appearance. Whatever the marketing strategy, it must be reinforced by the packaging because it is the last thing a potential customer sees before purchase.

TABLE 3—Estimated U.S. consumption of absorbent clay in thousands mt as compared to the commercial clay. After Santarén, 1993.

Year	1980	1985	1991	1996	2000
Absorbents	1,044	1,533	2,135	2,400	2,600
<b>PET WASTE</b>					
<b>ABSORBENT</b>	<b>621</b>	<b>943</b>	<b>1,480</b>	<b>1,655</b>	<b>1,800</b>
Oil and grease	423	590	655	735	800
% absorbent	2.3	3.6	5.0	5.0	4.9
Total commercial clays	45,901	42,234	42,990	49,000	53,500

TABLE 4—Consumption of U.S. absorbent clays in 1993 in mt. Source: R.L. Virta, U.S. Bureau of Mines, pers. comm., 1995.

Use	Bentonite	Fuller's Earth	Other Clays	Total
Oil and grease	—	259,091	—	259,091
<b>PET WASTE</b>				
<b>ABSORBENT</b>	<b>302,055</b>	<b>1,469,035</b>	<b>—</b>	<b>1,771,090<sup>1</sup></b>
Miscellaneous/ other absorbents	<u>66,436</u>	<u>42,738</u>	<u>10,069<sup>2</sup></u>	<u>119,243</u>
<b>TOTAL</b>	<b>368,491</b>	<b>1,770,864</b>	<b>10,069</b>	<b>2,149,424</b>

<sup>1</sup>Includes some kaolin and ball clay. <sup>2</sup>The small amount of other clays used as a pet waste absorbent is included with "Miscellaneous absorbents."



## Consumer demand

Scoopable, or clumping, cat litter is the newest wave to sweep the cat-litter industry. Through proprietary blends of mostly clay granules (0.5-2.0 mm), the litter forms a clump of the undesirable box contents, which can then be scooped out leaving the remaining material uncontaminated. This type of litter is used more efficiently since only contaminated litter is removed and lesser quantities are required. The litter tray can last up to a year with replenishing (O'Driscoll, 1992), but the instructions on many litter packages recommend monthly changing of litter. Some manufacturers, who do not include Na-bentonite in their formula, claim that the material will not swell and is therefore safe for flushing. While flushing animal waste in some areas is illegal, in others, it affords an extremely convenient method of disposal, with minimum litter consumption. The scoopable-type litters are primarily blends of palygorskite/attapulgitite and Na-bentonite, but some producers use zeolites as additives. Because lesser quantities are used, the scoopable litter is sold in convenient plastic jugs that are easy to store, neat (they will not rip like paper bags do), and more premium in appearance. Presently, 30% of the American cat-litter market is scoopable litters, which is expected to rise to 50% soon (Santarén, 1993). The European cat-litter market is expected to follow suit, although it was introduced to scoopable litter five years later.

Conventional cat litter refers to the traditional type of box filler that must be changed at some time interval depending on how well it disguises the undesirable box contents and how long it controls the odor. Some cats are particular about how clean the box is and will not use it after a certain period of time, in which case it is the cat that determines the changing schedule. A particularly finicky cat or owner will ultimately prefer the scoopable type of litter over the conventional type simply because the box retains the offensive contents for a shorter period of time.

## Producers, products, and prices

The Paleocene-age Porters Creek Clay crops out on either side of the Mississippi Embayment. It contains several minerals that are beneficial for cat litter, chiefly Casmectite and opal CT. Other clay minerals include illite, kaolinite, and lesser amounts of palygorskite/attapulgitite. The Porters Creek Clay is recognized in Alabama, Mississippi, Tennessee, Kentucky, Illinois, and southeast Missouri. Historically, more than 50% of domestic cat litter has come from this formation that is mined with front-end loaders and scrapers (Parker, 1979). As the scoopablelitter demand increases, however, this percentage may drop (S. Peterson, Zeotech Corporation, oral comm. 1993).

Cat litter is produced by many companies under a variety of names. Golden Cat Corporation, purchased by Ralston Purina, invests heavily in advertising and its Tidy Cat® brand is the largest seller in the United States. The company dominates the U.S. market with approximately 35% market share and approximately \$250 million in gross sales in 1994. The name Kitty Litter® is actually a trade name of Golden Cat Corporation who bought Lowe Industries, the first litter producer. Golden Cat Corporation, as well as other producers who mine and process the material they sell, put in their own particular additives (D. Scott, Golden Cat Corporation, oral comm. 1993).

Most of the scoopable-type litter comes from Wyoming. The dominant company in this market is First Brands.

Their "Scoop-Away" product, marketed through A & M Pet Products, is the leading scoopable litter. First Brands also markets Jonny Cat litter though recently purchased Excel Minerals. American Colloid Company owns the Upton, Colony, and Lovell operations in Wyoming, and produced 1.1 million mt of Na-bentonite in 1991. Wyo-Ben Inc. also produces Na-bentonite, which it sells to cat-litter producers for blending in their own scoopable-litter formulas (O'Driscoll, 1992). Currently, American Colloid Company holds the patent for using Na-bentonite in scoopable litters, so only a limited number of companies are allowed licensing privileges. So far they are Golden Cat Corporation, Excel-Mineral Ltd., and the Clorox Company (Santarén, 1993). American Colloid Company recently acquired fuller's earth mineral reserves, a mine, and a processing plant from Golden Cat. Part of the deal included the use of Na-bentonite by Golden Cat in their brands to achieve a scoopable cat litter (Anonymous, 1993). Oil-Dri Corporation of America mines a mixed deposit of montmorillonite and palygorskite/attapulgitite in Ochlocknee, Georgia, which it blends into its own clumping litter, Cat's Pride® (Table 2). The price of clumping litters is approximately three times more per unit weight than conventional types, but the values are comparable because clumping litters last so much longer (O'Driscoll, 1992).

Zeolites are still a small niche in the market. A clinoptilolite litter is produced in Tilden, Texas, by Zeotech Corporation, which markets it as the Kitty Crystals® brand. The Stone House Zeolite mine of the St. Cloud Mining Company near Truth or Consequences in south-central New Mexico also produces zeolites for cat litter; most of their product is sold to other companies for blending and/or marketing. Much of St. Cloud's "cat litter" actually ends up as potting soil, anti-skid agents, and floor-drying agents.

We attempted to understand how bags or plastic bottles of cat litter purchased at a supermarket can be compared to other containers of material purchased from the same store (Table 5). Prices will vary from store to store and region to region, but it is clear that the range is wide. Although a supermarket was used as source of material, low-cost discount stores presently are the fastest-growing section of retail marketers of cat litter (S. Peterson, Zeotech Corporation, written comm. 1995). As is clear from the description of litter source materials, price per weight is not adequate to evaluate products in many cases. Similarly, price per volume is not adequate. "Effectiveness of the product" per cost is difficult to define, as is evidenced by the saleability of "premium" (high-priced) products.

## Transportation

The lower-cost, bulk cat-litter products need to be sold near their source to keep prices down; these are the regionalized products. National producers such as Oil-Dri Corporation of America and Golden Cat Corporation haul their material by truck; this will become more economical as markets move toward lower-volume premium products. Oil-Dri markets its cat-litter products in Europe through Oil-Dri (UK) Ltd. Some premium products, such as hydrated calcium silicates and gypsum-based material, are distributed throughout Europe. Catsan, marketed by Effem GmbH in Germany, is shipped from the main producing plant in Frechen, Germany, to as far away as the UK (O'Driscoll, 1992). As scoopable litters gain ac-

TABLE 5—Value of pet litters purchased from Furr's Supermarket, Socorro, New Mexico, September 1994.

Product	Product type (by label description)	\$/weight	\$/lb	\$/mt
Cat's Pride	Smectite and attapulgite	\$3.95/10 lbs	0.3950	871
Control	Lightweight clay	\$2.89/7 lbs	0.4129	911
Fresh Step	—	\$2.89/7 lbs	0.4129	911
Jonny Cat	Clay	\$4.79/20 lbs	0.2395	599
Kitty Crystals	Clinoptilolite	\$3.55/25 lbs	0.1420	314
		\$1.69/10 lbs	0.1690	373
Kitty Litter (Max)	Clay blend	\$4.49/20 lbs	0.2245	495
(Scoopable)	Na-smectite	\$6.99/14 lbs	0.4993	1,101
Litter Green	Alfalfa and oathulls	\$4.79/10 lbs	0.4790	1,057
Tidy Cat	Clay	\$1.99/10 lbs	0.1990	439
Tidy Step (Multicat)	—	\$5.99/14 lbs	0.4279	944
		\$5.99/16 lbs	0.3744	826
Sorb Away	Clay blend	\$3.69/7 lbs	0.5271	1,163

ceptance in Europe, their American producers will be transporting them across the Atlantic along with other premium materials like high-quality palygorskite/attapulgite. Again, it is the premium quality that permits this.

#### Safety

**Dust**—The material used for cat litter needs to have as little respirable dust as possible. Mineral content may also be important. Crystalline silica has been linked to cancer by the International Agency for Research on Cancer (IARC). Non-sedimentary sepiolite, mined principally in Finland and China, may pose a potential health threat to humans (Santarén and Alvarez, 1994).

Whether a problem is real or perceived, it is significant when dealing with such a market-sensitive product. For example, a story is told about a diatomaceous-earth material that was considered for use as a cat litter, but X-ray diffraction analysis showed the possibility it contained crystalline silica in the form of cristobalite (Anonymous, 1981). The cat litter manufacturer explained the decision to discontinue investigations of the material as follows: "Your material may eventually be proved 'clean,' but it's just not worth our while getting involved with products that have a health hazard label, whether real or imagined. Dealing with potentially hazardous materials in human environments is bad enough, but can you imagine the backlash if it is suggested you are subjecting PETS to potential danger?"

**Chemical additives**—Almost every litter producer adds a blend of perfumes or colorants. These additives should be used in accordance with the FDA's regulations for incidental food contact and/or food contact. The producer needs to keep in mind that the filler material is a common household item that could possibly come into contact with small children as well as pets.

#### Future outlook

In 1962, there were over 63 million cats in the United States (Santarén, 1993), and the number is rising. The annual volume of the cat-litter market in Europe is one million tons, and with a rise in premium-product popularity, the value of this amount of tonnage is expected to increase. As cities increase in population, the number of cat owners who purchase litter is also expected to rise, thereby increasing sales. Any environmental benefits a producer can use to market its cat litter will also enhance sales. With new markets opening, such as the scoopable litter, the best way for a producer to stay competitive is to keep a versatile product line and a close eye on its market.

#### Acknowledgments

American Colloid, Zeotech, and Oil-Dri contributed informational packets and procedures that were used by us to build on published information on cat litter. Steve Peterson of Zeolite Corporation, Pat Freeman of St. Cloud Mining Company, and Bill Moll of Oil-Dri Corporation reviewed and commented on the manuscript. While not always agreeing on details, they nonetheless refined the manuscript to a more realistic appraisal of the cat-litter industry.

#### References

- Anonymous, 1981, Fillers and extenders: Industrial Minerals, no. 165, p. 65.
- Anonymous, 1991, Fillers and extenders, zeolite odour fighters: Industrial Minerals, no. 282, p. 78.
- Anonymous, 1993, World of minerals: Industrial Minerals, no. 304, pp. 15,17.
- Anonymous, 1995, Prices: Industrial Minerals, no. 329, pp. 66-67.
- Bradley, W. F., 1940, The structural scheme of attapulgite: American Mineralogist, v. 25, pp. 405-410.
- Clarke, G., 1985, Special clays: Industrial Minerals, no. 216, pp. 25-48.
- DeLapparent, J., 1935, The relation of the sepioliteattapulgite series of phyllitic silicates of the mica type: Comptes Rendus, v. 203, pp. 482-484.
- Elzea, J., and Murray, H. H., 1994, Bentonite; in Carr, D. D. (ed.), Industrial minerals and rocks, 6th ed.: Society for Mining, Metallurgy, and Exploration Inc., Littleton, Colorado, pp. 233-246.
- Fersman, A., 1913, Studies in magnesium silicates: Academy of Sciences (St. Petersburg), Memoirs, Series 8, v.32, pp. 323-365.
- O'Driscoll, M., 1992, European cat litter: Absorbing market growth: Industrial Minerals, no. 299, pp. 46-65.
- Parker, D., 1979, Potters Creek Clay, geology, processing, and marketing of a unique mineral assemblage: Society for Mining, Metallurgy, and Exploration Inc., Littleton, Colorado, Preprint 79-339,4 pp.
- Russell, A., 1991, Specialty clays: Market niches taken by unique properties: Industrial Minerals, no. 285, pp. 49-59.
- Santarén, J., 1993, European market development for absorbent clays: Industrial Minerals, no. 304, pp. 35-47.
- Santarén, J., and Alvarez, A., 1994, Assessment of the health effects of mineral dusts: Industrial Minerals, no. 319, pp. 101-117.



# Domestic pumice and garment wet-processing

Jerry M. Hoffer

*Department of Geological Sciences, The University of Texas at El Paso, El Paso, Texas 79968-0555, USA*

**Abstract**—Garment wet-processing utilizes pumice to fade and soften denim fabrics. In acid-washing, the pumice is impregnated with oxidizing chemicals, bleach and/or potassium permanganate, that are released onto the fabric during tumbling and chemically remove the indigo dye, thereby bleaching the fabric. In stone-washing, garment softening and bleaching are produced by the removal of the dye by the abrasive action of the stone surface on the fabric.

The major pumice physical properties that influence the garment abrasion include apparent density, absorption capacity, and abrasion loss. Secondary properties include the amount of surface fines, moisture content, and the presence of surface staining. The acid-wash process requires a stone that absorbs a large quantity of oxidizing chemicals, such pumices generally possess moderate abrasion loss and apparent density. High-moisture content and abundant surface fines can dilute or reduce the amount of absorbed chemical, respectively. Stone-wash requires a harder pumice with higher apparent density because of the longer wash cycle; absorption capacity is not a factor because the garment bleaching is physical, not chemical in origin.

Approximately 200 domestic pumice deposits have been identified, but only 18 contain 3/4 inch fragments, the minimum size required for wet processing, and possess suitable physical properties for acid- or stone-washing. Currently the three major producers in the United States, in order of decreasing production, are Copar Pumice Company (Sandoval County, New Mexico), Arizona Tufflite Inc. (Coconino County, Arizona), and Glass Mountain Pumice Inc. (Siskiyou County, California). Lesser amounts of laundry pumice are supplied by Cascade Pumice Inc. (Klamath County, Oregon), and General Pumice Corporation (Rio Arriba County, New Mexico). Six additional deposits of possible future production include three in Idaho and one each in Arizona, California, and New Mexico.

Domestic garment wet-processing initiated in the early 1980s. Stone-washing was popular from 1982 to 1986, followed by acid-washing from 1987 to 1991. In late 1991 the acid-wash look began to decline, and stone-washing returned to popularity and has remained so up to the present time. During the height of acid-wash usage the domestic consumption of laundry pumice peaked in 1989 at an estimated 81,000 metric tons (mt) and then declined to 47,000 mt in 1994. The current consumption remains depressed in 1995 and has been attributed to the use of enzymes, environmental concerns, and implementation of the North American Free Trade Agreement.

Pumice is mined by open-pit methods. Mining, cleaning, and screening costs range from \$0.0055 to 0.012 /lb (\$12.10 to 26.40 /mt); bagging adds an additional \$0.0015 /lb (\$3.30 /mt). Therefore the cost to produce and bag the pumice ranges from \$0.007 to 0.0135 /lb (\$15.40 to 29.70 /mt). The retail price delivered at the laundry, which includes the costs of transportation and broker or distributor commissions, was approximately \$0.40 /lb (\$880 /mt) in 1984 has fallen from \$0.10 to 0.12 /lb (\$220 to 264 /mt) in 1994.

## Piedra pómez doméstica y su use en el tratamiento por lavado de prendas de vestir

**Resumen**—El tratamiento por lavado de prendas de vestir utiliza la piedra pómez para desteñir y suavizar las telas de *denim*. En un lavado ácido la piedra pómez se impregna con sustancias químicas oxidantes o descolorantes y/o permanganato de potasio. Al agitar las prendas esas sustancias penetran la tela y químicamente extraen la tintura de indigo y así destiñen las prendas. En el lavado a piedra, es la abrasión la que suaviza y destiñe las prendas.

Las propiedades físicas principales que afectan la abrasión de las prendas son la densidad aparente de la piedra pómez, su capacidad de absorción y su desgaste por abrasión. Propiedades secundarias son la proporción de finos que cubren la superficie de las piedras, contenido de humedad y coloración superficial. El proceso de lavado ácido requiere piedra que absorbe gran cantidad de sustancias oxidantes, y estas variedades de piedra pómez suelen sufrir moderada pérdida por abrasión y tener densidad aparente también moderada. Un alto contenido de humedad y abundancia de finos superficiales puede diluir y disminuir, respectivamente, la sustancia absorbida. Por que el ciclo del lavado es mas largo, un lavado a piedra requiere una piedra pómez de mayor dureza y con una densidad aparente mas alta. En cambio, la capacidad de absorción no importa porque el desteñido de la prenda es por acción física y no química.

Se han identificado unos 200 yacimientos domésticos de piedra pómez, pero sólo 18 de ellos contienen fragmentos de 3/4 de pulgada, que es el tamaño mínimo necesario para el tratamiento por lavado, y también poseen las demás propiedades físicas requeridas para el lavado ácido o de piedra. Actualmente, los tres productores principales en los E.U.A., en orden de producción decreciente, son *Copar Pumice Co.* (Condado de Sandoval, Nuevo Mexico), *Arizona Tufflite, Inc.* (Condado de Coconino, Arizona) y *Glass Mountain Pumice, Inc.* (Condado de Siskiyou, Califor-

nia). *Cascade Pumice, Inc.* (Condado de Klamath, Oregon) y *General Pumice Corp.* (Condado de Rio Arriba, Nuevo Mexico) producen cantidades menores de piedra pómez para lavado. Se conocen seis yacimientos adicionales que podrían producir en el futuro, tres se encuentran en el estado de Idaho y uno en cada uno de los estados Arizona, California y Nuevo Mexico.

El procesamiento doméstico de prendas por lavado comenzó a principios de los años 1980. Lavado a piedra era popular de 1982 a 1986, seguido por lavado ácido entre 1987 y 1991. Tarde en 1991 lavado ácido empezó a declinar y fue desplazado nuevamente por el lavado a piedra cuya popularidad continua hasta el presente. El consumo de piedra pómez para lavado ácido culminó en 1989 con un consumo de 81,000 toneladas métricas (tm) para declinar a 47,000 toneladas en 1994. El consumo continua deprimido en 1995, lo cual se atribuye al uso de enzimas, problemas ambientales e implementación del Acuerdo Norteamericano del Comercio Libre (NAFTA).

La piedra pómez se explota a cielo abierto. El costo de extracción, purificación, limpieza y cribado varia entre 0.0055 y 0.012 dólares (USA) por libra (\$12.10 a \$26.40 / tm); el embolsado agrega \$0.0015 por libra (\$3.30 / tm). Entonces, el costo total de producción y embolsado varia de \$0.007 a \$0.0135 por libra (\$15.40 a \$29.70 / tm). El precio de venta por menor entregado en lavandería, que incluye el costo de transporte y comisión del agente o distribuidor, era de unos \$0.40 / libra (\$880 / tm) en 1984, pero ha disminuido de entre \$0.10 y \$0.12 / libra (\$220 a \$264 / tm) en 1994.

### Introduction

Garment wet-processing has evolved from a fad during the early 1980s to the way of doing business for most fabric and apparel producers (Playor and Strickland, 1995). Blue jeans have evolved from rigid starch-finished products to multi-colored, soft, and bleached fabrics through garment-wet-processing methods.

### Garment-wet-processing methods

Garment wet-processing involves the use of pumice, with or without chemicals, during the laundering of denim fabrics. The net result of the process is to soften and bleach the garment.

Two distinct processes are utilized in garment wet-processing: (1) acid-washing and (2) stone-washing. In acid-washing the pumice is impregnated with oxidizing chemicals, potassium permanganate and/or bleach, and then tumbled with the damp denim fabric at a ratio of rock to garments of approximately 1:2. The chemicals are slowly released from the pumice onto the garment and partially remove the cellulose-based indigo dye that has been used to color the denim yarn. When the desired degree of bleaching is achieved (after 15-30 min) the garment is removed from the laundry machine, destoned, and neutralized with sodium bisulfite or hydroxylamine and then washed and pressed (Table 1). In stone-washing the pumice is tumbled with the fabric and water; the bleached look is produced by the abrasive action of the stone on the outer surface of the fabric. When the desired finish is obtained (30-90 min) the garment is destoned, washed, and pressed.

A multitude of different finishes can be produced during stone-washing ranging from a splotchy pattern of high contrast to an even finish of light-blue to nearly white color. These different "looks" can be produced by varying the length of the wash, the ratio of pumice to garment, or the size and abrasiveness of the pumice (Fig. 1).

### History of domestic garment processing

The initial garment processing method was stone-washing, which initiated during 1982 and was popular through 1986. Near the end of 1986 the acid-wash look was introduced from Europe, and the market for pumice use in garment finishing rapidly expanded in this country. The acid-wash finish was extremely popular through 1987 until late 1991 to early 1992. During this later period acid-washing began to decline because of two factors. The first

was the environmental effects associated with acid-wash chemicals and the disposal of large amounts of pumice fines into overcrowded landfills. The second, and more compelling factor, was a law suit involving patent infringement. Therefore, stone-washing has re-emerged as the major wet-processing method employed by domestic garment finishers since late 1991.

In late 1991 and early 1992 the use of enzyme powders became popular with El Paso laundry finishers. The cellulase enzymes attack and degrade the cloth dye chemically and have a minimal effect on the denim fabric itself. The use of enzymes reduces the amount of pumice needed to bleach denim. The enzymes are biodegradable and can be placed directly into the municipal sewer systems. Reducing the quantity of pumice will result in less drum damage in the rotary washers and lessen the formation of abrasion-derived pumice fines.

Some laundries have tried to eliminate all pumice in the processing and use all enzymes. However, several laundries have indicated that eliminating pumice is a mistake because the pumice aids in the removal of enzyme-weakened surface fibers, which results in a cleaner and smoother surface appearance. In addition, a number of garment finishers have reported an increase in garment damage from the use of the enzymes.

### The role of garment finishers

A number of major domestic garment manufacturers, such as Levi Strauss, Wrangler, Lee Company, and Sun Apparel, produce such a large number of garments that they "farm out" a large amount of their finishing work to laundries that specialize in producing acid-wash and stone-wash "looks." Currently in El Paso, more than 20 laundry finishers have evolved to produce stone-wash finishes for both local and out-of-state companies and several in foreign countries.

The laundry finishers work for the garment manufacturer on a contract basis. The manufacturer furnishes the laundry a "standard" displaying the desired finish, and the laundry then develops a method to duplicate this "look" on the garment at a reasonable cost. If successful the laundry receives a contract to finish a specific number of garments at a specific price and time.

The garment industry is one of El Paso's major employers. In February 1994 over 20,000 people were employed in the garment industry; it is estimated that 6,000-7,000 people work in the garment-finishing field (*El Paso Times*, February 20, 1994).

TABLE 1—Flow sheet of garment wet processing methods.

ACID-WASH			
Pumice impregnated with oxidizing chemicals, bleach, and/or potassium permanganate + garments + water	→ Tumble in rotary washer, 15–30 min	→ Garments removed, destoned and neutralized with sodium bisulfite	→ Garments washed, dried, and pressed
	↓ Fines (<3/8 inch) drop out and neutralized with sodium bisulfite solution	→ Waste water screened to remove coarse waste; sandtraps remove fines	→ Cleaned waste water to sewer
	↓ Neutralized fines removed and placed in dumpster		
	↓ Removed to landfill		
STONE-WASH			
Pumice + garments + water	± Enzymes → Tumble in rotary washer, 30–90 min	→ Garments destoned, washed, dried, and pressed	
	↓ Fines + waste water screened, then passed through sand traps	→ Waste water to sewer	
	↓ Fines to dumpster and placed in landfill		

### Identifying suitable pumice for laundry use

In 1988 the author initiated a program, supported by East-West Apparel Inc. of El Paso, to identify the physical properties of pumice that control its effectiveness in both acid- and stone-washing. The initial purpose was to eliminate unsuitable pumices without having to actually test them on goods. Several hundred pumice samples from both identified and unidentified domestic and foreign deposits were tested, and the results correlated to the resulting garment finishes.

The identification of specific physical properties evolved over a period of 2-3 years. In 1988 acid-wash was popular so it was important to identify stone that would absorb large amounts of oxidizing chemicals—this is measured by the absorption capacity. When stone-wash became dominant in late 1991, a hard pumice that would abrade slowly was desired—this was measured by the abrasion loss. Surface fines were measured on pumices when it was discovered that they reduce absorption and increase the amount of fines produced during tumbling. The moisture index was introduced when pumices arrived at the laundry "dripping wet," and it was noted that, because pumice is purchased by the pound, money was being paid for water. Today six major physical properties are tested routinely on pumice; they include percentage of surface fines and moisture, absorption capacity, apparent density, and abrasion loss.

#### Surface fines

Surface fines include fine-grained glass fragments and/or clay minerals that adhere to the outer surface of the pumice. The glass fragments result from fragmentation of the pumice vesicle walls. If they are abundant,

exceeding about 4% of the pumice by weight, glass fragments can plug the vesicles and reduce the amount of absorbed chemical for acid-washing. In addition fines will increase the total suspended solids (TSS) in the waste water from stone- or acid-washings.

Alteration products, such as smectite clay, occasionally form on the outer surface of the pumice. The clay not only reduces pumice absorption, but during acid-washing, it will absorb and release the oxidizing chemical faster than pumice resulting in a bleach streak across the fabric.

Measurements of surface fines from 282 pumice samples range from 0.1 to 19.8 wt.%; the average value is 3.9% wt.% and the median 3.3 wt.%. Their distribution is bimodal with nearly 35 wt.% of the samples containing less than 1.6 wt.% fines, whereas over 37 wt.% contained in excess of 4.8% fines.

Approximately 95% of the fines are less than 0.7 mm in diameter and nearly 30% are less than 0.04 mm. A majority of the <0.04 mm material will pass through conventional traps and end up as TSS in the laundry waste waters.

It is recommended that stone-washing pumices containing more than 4% fines by weight be rejected. For acid-washing a higher fines content can be tolerated, especially if the pumice possesses a high absorption capacity that will enable it to absorb a large quantity of oxidizing chemical (Table 2).

#### Moisture content

One of the common occurrences at laundries is receiving wet pumice from suppliers. Moisture is absorbed by pumice during periods of precipitation, and the amount of water entering the rock depends upon size, amount,

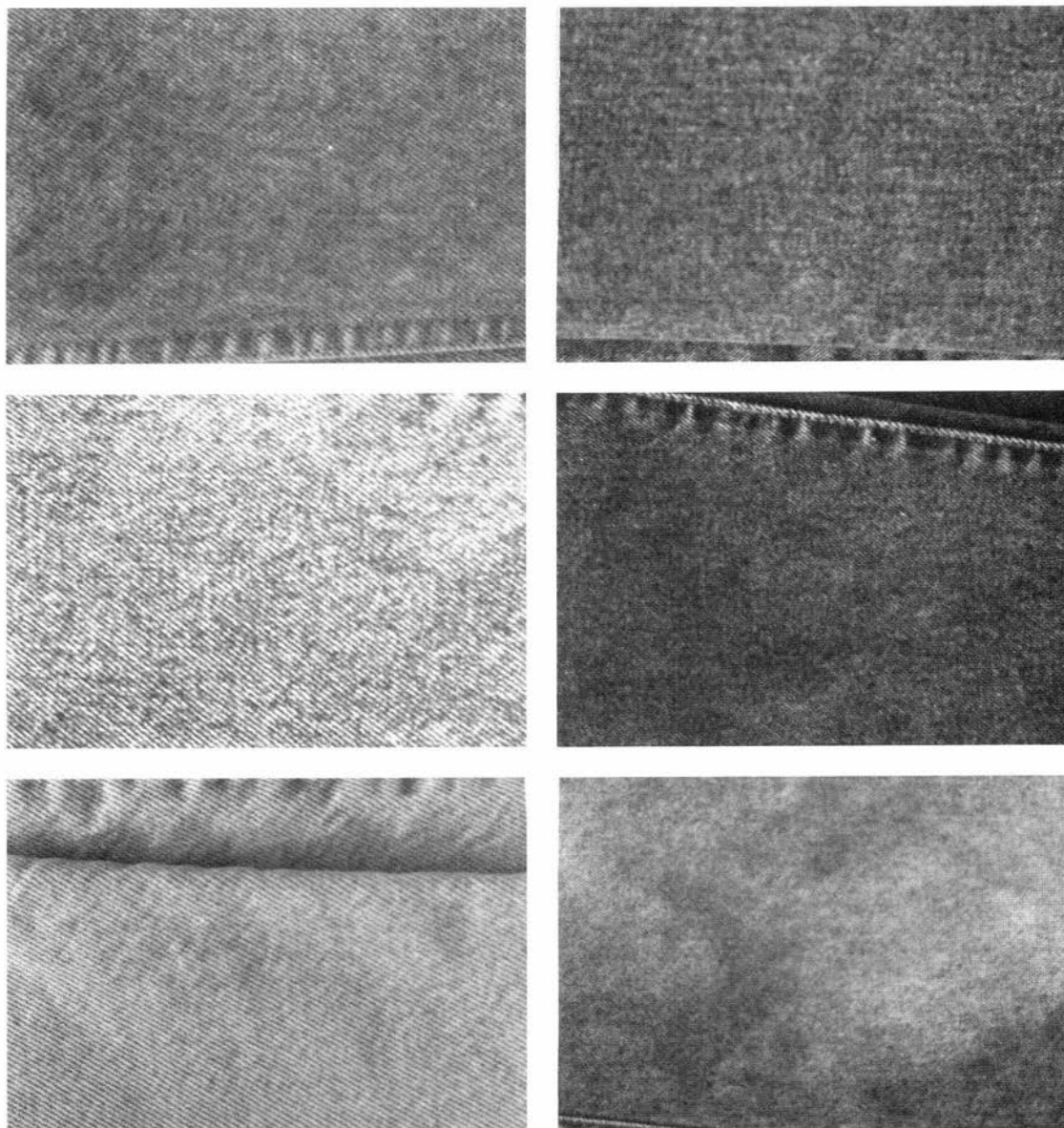

FIGURE 1—Acid- and stone-washed denim fabrics. Left (top): normal acid-wash with bleach; (middle): close-up of normal acid-wash with bleach; (bottom): long-cycle acid-wash with bleach. Right (top): normal stone-wash; (middle): light stone-wash; (bottom): light stone-wash and sandblasting (light areas).

and degree of connectiveness of the vesicles (i.e. vesicle-derived permeability) and the amount of time in contact with the moisture.

Moisture in pumice can effect the laundry in either of two ways: (1) If the pumice is impregnated with an oxidizing chemical for acid-washing, the initial moisture will dilute the concentration of the chemical, and (2) if the pumice is purchased by weight, a portion of the cost is for the water, not the rock.

The amount of moisture absorbed by pumice varies seasonally. During the wet months, the moisture content will reach a maximum and then decrease by evaporation during dry months. Pumice deposits in the western United States (northern California, Oregon, Arizona, and New Mexico) receive abundant winter snow from November through March. In Mexico and central America the rainy season extends from late June through September. Turkish pumice deposits have been reported to con-

TABLE 2—Recommended pumice physical properties for use in acid-washing or stone-washing (modified from Hoffer, 1993).

Pumice properties	Acid-wash specification	Stone-wash specification
Surface fines	<5 wt.%	<5 wt.%
Moisture	<5 wt.%	Not a factor unless purchased by the pound
Absorption capacity	25–30 wt.%	<20 wt.%
Apparent density	0.50–0.70 g/cm <sup>3</sup>	0.70–0.85 g/cm <sup>3</sup>
Abrasion loss	26–30 wt.%	20–25 wt.%
Surface coloration	<1 wt.% iron oxides	<10 wt.% iron oxides



tain as high as 30 wt.% moisture during winter months (November through March) versus 15 wt.% moisture during drier summer months.

Measured moisture values, based upon testing of 178 samples, range from 0.2 to 44 wt.% the average is 13.2 wt.% and the median is 10.0 wt.%. The recommended limit for acid-wash pumice is about 5% or less, by weight (Table 2). In stone-washing moisture is not a factor unless the pumice is purchased by the pound.

### Absorption capacity

Absorption capacity, one of the major pumice physical properties, is important in garment-wet processing. In the acid-wash process pumice is impregnated with oxidizing chemicals and then tumbled with damp garments. The absorbed chemicals are released onto the surface of the goods and bleach the indigo dye by oxidation. The amount of liquid absorbed by the pumice in weight percent is referred to as the absorption capacity. In most laundries, pumice is impregnated by simple submergence in dilute solutions of bleach or potassium permanganate for approximately 5 min or less.

A total of 467 pumice samples have been tested for absorption capacity. Values measured range from 1 to 68 wt.%; the average is 23.2 wt.% and the median is 22.5 wt.%. The absorption capacity of selected domestic pumices are shown in Table 3. The absorption capacity for an acid-wash pumice should equal or exceed 30 wt.%; for stone-washing, the absorption capacity is not a factor because the pumice does not carry any chemicals.

### Apparent density

Although the true density of pumice is about 2.5 g/cm<sup>3</sup>, its cellular structure gives it a general apparent

density of less than 1.0 g/cm<sup>3</sup>. The apparent density can be determined by the method of water displacement.

A wide range of apparent densities can be tolerated in the washing process, but the most acceptable are those between 0.50 and 0.95 g/cm<sup>3</sup>. Pumice densities greater than 0.85 g/cm<sup>3</sup> when placed in water will absorb enough fluid that its density will exceed 1.0 g/cm<sup>3</sup>, and it will sink. Most stone-washing pumices have apparent densities from 0.70 to 0.85 g/cm<sup>3</sup>. For acid-washing the pumice should have high absorption capacity so it can absorb the maximum amount of oxidizing chemical; such pumices generally possess apparent densities ranging from 0.50 to 0.70 g/cm<sup>3</sup>.

A total of 403 pumice samples have been evaluated for apparent density, which ranges from 0.32 to 1.93 g/cm<sup>3</sup> with the average and median values of 0.68 and 0.66 g/cm<sup>3</sup> respectively. The apparent density values of selected domestic pumice is included in Table 3.

### Abrasion Loss

The rate of disintegration of pumice during tumbling is referred to as the abrasion loss. The abrasion property is measured by placing 5-10 lbs of pumice in a rifle machine and tumbling it for 15 min. The pumice is initially weighed and then reweighed after tumbling; the percentage of weight loss is reported as the abrasion loss. The abrasion loss is an index indicating the relative pumice hardness and is used to compare the disintegration rates of various pumices.

A total of 346 pumice samples have been tested for abrasion loss; values range from 11 to 72 wt.% with both the average and median at 31 wt.%. Pumices with abrasion loss values of less than 25 wt.% are referred to as hard, 26-33 wt.% medium, and greater than 34 wt.% as soft.

TABLE 3—Physical properties of selected domestic deposits for laundry use (nd = not determined).

Pumice	Absorption capacity (wt.%)	Apparent density (g/cm <sup>3</sup> )	Abrasion loss (-wt.%)	Surface fines (wt.%)	Moisture Content (wt.%)	+3/4 inch (wt.%)	Laundry use
<u>California</u>							
Coso Mountains, Inyo Co.	23.0	0.74	26.3	nd	6.1	19.3	Stone-wash
Benton, Mono County,	36.2	0.55	33.3	nd	8.1	2.8	Acid-wash
Glass Mountain, Siskiyou Co.	12.0	0.69	36.3	0.8	4.4	10.0	Acid-wash
Mono Craters, Mono Co.	31.5	0.53	48.5	nd	nd	>30.0	Acid-wash
Little Glass Mountain, Siskiyou Co.	28.7	0.65	30.6	1.5	7.8	15.0	Acid-wash
<u>Idaho</u>							
Hess Pit, Oneida Co.	10.8	1.38	38.4	nd	4.3	12.5	None
Bonneville Co.	23.3	0.70	42.1	3.3	4.6	2.0	Acid-wash
Magic Reservoir, Blaine Co.	13.2	0.84	34.1	1.0	0.8	33.3	Stone-wash
Tetonia Co.	26.8	0.62	41.7	0.8	nd	2.0	Acid-wash
<u>Arizona</u>							
White Vulcan, Coconino Co.	18.8	0.70	25.2	1.8	23.1	25.0	Stone-wash
Moody Pit, Coconino Co.	14.4	0.92	30.1	1.5	nd	25.5	None
Deadman Flat, Coconino Co.	24.0	0.62	31.0	1.6	nd	19.1	Acid-wash
<u>Utah</u>							
Mineral Mountains, Beaver Co.	10.0	0.85	22.7	0.6	3.7	10.0	Stone-wash
<u>New Mexico</u>							
Guaje Canyon,							
Sante Fe and Rio Arriba Co's.	22.0	0.73	26.3	nd	nd	5.6	Stone-wash
Las Conchas, Sandoval Co.	24.6	0.76	23.3	2.9	10.3	43.6	Stone- or acid-wash
E. Grants Ridge, Cibola Co.	8.0	0.76	17.0	0.2	2.5	14.0	Stone-wash
<u>Oregon</u>							
Bend, Deschutes Co.	24.4	0.72	26.0	1.9	14.9	5.0	Acid- or stone-wash
Beaver Marsh, Klamath Co.	35.5	0.59	37.2	0.7	0.8	>35.0	Acid-wash

The abrasion loss values of selected domestic pumice are in Table 3.

Low abrasion-loss pumices (25 wt.% or less) indicate slow disintegration during tumbling with the garments and are most desirable for stone-washing. Such pumices generally possess high apparent densities ( $>0.70$  g/cm<sup>3</sup>), and low absorption capacity ( $<25$  wt.%). For acid-washing pumice, abrasion loss is generally higher. This is because the high-absorption-capacity stones are generally lighter, apparent density ( $<0.70$  g/cm<sup>3</sup>), more porous, and therefore possess abrasion losses ranging from 30-40 wt.%.

### Surface coloration

Pumice is generally off-white to gray in color. Occasionally pumice fragments will possess a tan- to yellow-brown coloration due to the presence of iron oxides. The iron compounds are secondary deposits in and on the pumice. In pumice deposits overlain by several feet of soil or alluvium, precipitation percolates through the overburden, leaches out iron oxides, and redeposits them both on the surface and in the vesicles of the underlying pumice as impurities.

In acid-washing the presence of iron-stained pumice can be a problem, especially if it exceeds 5-10% of the pumice surface. The iron oxides can be mobilized by the oxidizing chemicals and subsequently deposited on the garments during tumbling. The result is a light yellow or brown color on the finished garment. In stone-washing the problem is not as acute. However, the use of high concentrations of acid enzyme could produce similar results.

### Laundry-grade pumice deposits

Pumiceous materials are formed from areas of explosive volcanism in which high-silica materials (65-75% SiO<sub>2</sub>) have erupted. Such areas occur in the western United States and include the active volcanoes of the Cascade Mountains in northern California, Oregon, and Washington. In addition numerous deposits have been produced from young volcanic centers within the Basin and Range province in California, Arizona, New Mexico, Nevada, and Idaho. Fresh, unaltered pumice materials are restricted to strata of relative young age, less than about 5 million years (Hoffer, 1994).

### Deposits

A search of the geological literature revealed the existence of 202 late Cenozoic pumice deposits, locations, or quarries in nine western states and Hawaii. Based on the

reported descriptions, only 44 locations contained pumice with a minimum of 3/4 inch diameter; the smallest size pumice generally used by garment finishers (Table 4). In addition, pumice occurrences were eliminated from consideration if the pumice fragments occurred in welded tuffs and were, therefore, not easily minable or if the deposit was located on lands unavailable for mining.

Samples from these 44 occurrences were obtained, and their physical properties measured and evaluated in late 1992; 18 pumice deposits were identified as being suitable for laundry use (Table 4). The potential laundry-grade deposits occur in Arizona, California, Idaho, Utah, Oregon, and New Mexico.

Most of the past producers have left the laundry market because their pumice was only marginally effective (Hess Pit, Idaho, and Moody Pit, Arizona), lacked sufficient quantities of coarse pumice (Benton, California; Bonneville County, Idaho; and Bend, Oregon), or as in the case of U.S. Pumice, Mono County, California, was used in the higher-priced abrasive market.

The present major laundry pumice producers include, in order of decreasing production, Copar Pumice Company (Sandoval County, New Mexico), Arizona Tufflite Inc. (Coconino County, Arizona), and Glass Mountain Pumice Inc. (Siskiyou County, California). Minor amounts of pumice are produced by General Pumice Corporation (Rio Arriba County, New Mexico) and Cascade Pumice Inc. (Klamath County, Oregon).

Six deposits of possible future production have been identified. Three occur in Idaho and include occurrences in Bonneville, Blaine, and Tetonia counties. These deposits range from marginal (Bonneville and Tetonia Counties) to average (Magic Reservoir in Blaine County). Deadman Flat, Arizona, Little Glass Mountain, California, and East Grant's Ridge, New Mexico, deposits are above average and are most likely to be developed for future production.

### Markets and consumption

The leading states in the production of pumiceous materials, in decreasing order, include Oregon, New Mexico, California, Idaho, and Arizona. From 1990 through 1993 the domestic consumption of pumiceous materials, for all uses, averaged 632,500 mt/year; approximately 200,000 mt/year were imported representing almost 32% (Bolen, 1994). New Mexico and Arizona, followed by California, produce nearly all of the domestic pumice consumed by laundries.

TABLE 4—Survey of western domestic pumice deposits for laundry usage.

State	Reported pumice deposits <sup>2</sup>	Pumice deposits containing 3/4 inch fragments	Pumice properties suitable for laundry use <sup>1</sup>	Laundry production past or future		Present laundry production
Arizona	34	5	3	1	1	1
California	52	9	5	3	1	1
Idaho	18	6	4	1	3	0
Utah	4	1	1	1	0	0
Hawaii	3	1	0	0	0	0
Washington	18	9	0	0	0	0
Oregon	25	7	2	1	0	1
New Mexico	25	6	3	0	1	2
Nevada	8	0	0	0	0	0
Colorado	15	0	0	0	0	0
Totals	202	44	18	7	6	5

<sup>1</sup>prior to 1986 almost any pumice was utilized for laundry use; since that date, only high-grade pumices identified on the basis of specific physical properties are employed; <sup>2</sup>Asher, 1965; Carithers, 1946; Chesterman, 1956; Geitgey, 1992; Hoffer, 1991, 1994; Williams and Surgin, 1960; Horton, 1964; Van Horn, 1964; Carrillo, 1988.

## Markets

The major markets for laundry pumice are located in Los Angeles, California, and El Paso, Texas. A third important area exists in the southeastern part of the country where a large number of garment finishers are located in Georgia, Alabama, Tennessee, North Carolina, and South Carolina.

Both Copar and Arizona Tufflite sell most of their pumice to the nearby markets in Los Angeles and El Paso, and lesser amounts to the more distant laundries in the southeast. Their major competition in the western markets is from Mexican and Ecuadorian pumices. Because the southeastern markets are so distant from the western producers and due to cheap water freight rates, the foreign pumices can compete with the domestic suppliers in this region. Other foreign pumices utilized include those from Turkey, Ecuador, and minor amounts from Greece.

## Consumption

The utilization of pumice in garment finishing did not start in the United States until the early 1980s. In 1982 the first pumice for laundry use was imported from Iceland and utilized in the northeastern part of the country. It was not until 1984 that domestic pumice from California (Coso Mountains and Mono Craters) and Idaho (Hess pit) were utilized in garment processing. From 1986 to 1987, additional domestic production was initiated by Glass Mountain Pumice (Siskiyou County, California) and Arizona Tufflite (Coconino County, Arizona). In late 1989 Copar Pumice Company began to produce laundry-grade pumice from the Jemez Mountains in northern New Mexico. Today Copar is probably the largest domestic producer of wet-processing pumice.

The laundry use of domestic pumice started slowly in this country during 1984 with stone-washing (Table 5). In 1987 the acid-wash look arrived from Europe and increased the demand for pumice. Acid-washing consumes more pumice than stone-washing because it utilizes a softer stone possessing a high absorption capacity. In late 1988 through 1989 a slow down in garment finishing occurred and consumption of pumice declined (Table 5).

The acid-wash process began to decline in late 1990 because of the two factors mentioned previously—the environmental effects of the acid-wash chemicals and the law suit involving a claim of patent infringement with the acid-wash process.

With the decline in acid-washing, stone-washing production increased in popularity among the finishers in

1991 and has continued throughout 1994. During the last quarter of 1992 the consumption of laundry pumice began to decline. The decrease in laundry pumice use correlates with the increased use and efficiency of enzymes, environmental problems of the disposal of large quantities of pumice fines, and the acceleration of free trade with Mexico (NAFTA). The decrease in pumice consumption by garment finishers has continued throughout 1994, but now appears to have stabilized.

## Production and market price

### Production methods and costs

Most commercial pumice deposits are unconsolidated and have a minimum of overburden. Open-pit mining is employed with conventional loading equipment. The pumice is removed in bulk and then screened into the various size fractions as required by the construction and laundry industries. Mining, screening, and cleaning costs range from \$0.0055 to 0.012/lb (\$12.10 to 26.40/mt) depending on the thickness of the overburden, and the abundance of the lump pumice. If the pumice is bagged, as most laundries prefer, the additional cost is approximately \$0.0015 /lb (\$3.30 /mt). Therefore, the cost to produce the pumice ranges from \$0.0055 to 0.012/lb (\$12.10 to 26.40/mt), bulk, or \$0.007 to 0.0135/lb (\$15.40 to 29.70/mt) bagged.

Transportation costs to move the pumice from the mine to the laundry amounts to about \$1.353 mi for a 44,000 /lb capacity truck. The cost to truck a load from Arizona Tufflite's Phoenix plant to Los Angeles, a distance of approximately 390 mi, would be about \$0.012 /lb (\$26.33 /mt) or \$526.50.

### Market price

The factors that determine the market price of laundry pumice include: (1) transportation costs, (2) use of a broker or distributor, (3) extra preparation expenses, and (4) demand for a specific type of pumice.

Transportation costs were discussed in the previous section on production and costs. When the shipping costs exceed the value of the pumice, it becomes uncompetitive in the market place; this occurs at distances of 1,200-1,500 mi from the mine.

A distributor will purchase the pumice, in bulk, from the producers, bag it with his own label, and sell it directly to individual laundry finishers. A number of distributors will sell pumice from more than one producer and the producer may sell to more than one distributor. On the other hand, a broker will hold a exclusive contract with a producer so that he controls the entire distribution of all the producer's pumice. The use of distributors or brokers will result in lower producer profits or an increase in the price of the pumice to the laundry, or both. Extra preparation expenses such as drying wet pumice, special bagging, or unusual size requests will be passed directly to the laundry by the producer.

Occasionally, a broker or distributor will claim that a specific pumice is unique in that it will produce a certain garment finish that cannot be duplicated by another stone. If enough laundries believe this, the pumice will command a premium price. Such a case occurred in the late 1980s when a specific pumice was claimed to be the only stone that could produce a unique acid-wash finish termed "electric look," which was extremely popular and profitable. When the above pumice was unavailable during the winter months, the "electric look" was achieved by other pumices.

TABLE 5—Total domestic pumice consumption for all uses, and laundry consumption, 1985–1994 (e = estimated; data from Bolen, 1994 and 1992, and personal files).

Year	Total consumption in U.S.; all uses (1000 mt)	Pumice consumed in domestic laundries (1000 mt)	Percentage of laundry use (wt.%)
1985	508	5 <sup>e</sup>	1.0
1986	554	25	4.5
1987	392	80	20.4
1988	353	70	19.8
1989	424	81	19.1
1990	703	73	10.4
1991	506	69	13.6
1992	724	59	8.2
1993	594	49	8.3
1994	600 <sup>e</sup>	46	7.7

In early 1984 the only available domestic laundry pumice was Featherock, produced by U.S. Pumice from Mono Craters, California, and it was sold to laundries for \$0.40/lb (\$880/mt). By 1986 as more producers and distributors entered the market, the price dropped from \$0.18 to 0.17/lb (\$396 to 374 /mt) for Glass Mountain pumice to as low as \$0.11/lb (\$242/mt) for Arizona Tufflite pumice.

Today the price of high-quality laundry pumice can be purchased in El Paso for \$0.10-0.12/lb (\$220-264/mt); lesser grades sell for \$0.08-0.09/lb (\$170-198/mt). These prices are for bagged pumice, bulk shipments can be purchased for as low as \$0.06 /lb (\$132 / mt). The prices in the Los Angeles area are approximately the same as El Paso, whereas in the southeastern market, the prices are \$0.01-0.02/lb (\$22-44/mt) higher due to additional transportation costs. These above prices have not changed significantly during the last two years.

### Summary

Garment wet-processing utilizes pumice for both acid-and stone-washing. In acid-washing the pumice should possess high absorption capacity and moderate abrasion loss whereas stone-washing requires a stone with low abrasion loss.

Current laundry pumice producers include, in order of decreasing production, Copar Pumice, New Mexico; Arizona Tufflite, Arizona; Glass Mountain Pumice, California; Cascade Pumice, Oregon; and General Pumice, New Mexico. The consumption of domestic pumice has remained rather constant from 1988 through 1994 averaging approximately 32 mt. The price of laundry pumice has fallen from \$0.40 /lb (\$880/mt) in 1982 to \$0.10 /lb (\$220 /mt) in late 1994.

The major markets include Los Angeles, California; El Paso, Texas; and the southeastern United States adjacent to major textile mills.

### Acknowledgements

Thanks are extended to George Austin, New Mexico Bureau of Mines and Mineral Resources, and Kenneth Clark Department of Geological Sciences, University of Texas (El Paso), who reviewed the manuscript and offered suggestions that improved the paper.

I also would like to acknowledge the financial support provided by Mitch Brasington, former president of East-West Apparel Inc. Special thanks are extended to Roger D. Marion, regional geologist, Southwestern Region of the U.S. Forest Service, who coordinated the collection of samples from pumice deposits within Forest Service's lands in Washington, Oregon, Idaho, California, and Arizona, for my testing and evaluation.

### References

- Asher, R. R., 1965, Volcanic construction materials in Idaho: Idaho Bureau of Mines and Geology, Pamphlet 135, 150 pp.
- Bolen, W. P., 1992, Pumice and pumicite; *in* Mineral Commodity Summaries 1991: U.S. Bureau of Mines, pp. 1-5.
- Bolen, W. P., 1994, Pumice and pumicite; *in* Mineral Commodity Summaries 1993: U.S. Bureau of Mines, pp. 1-5.
- Carrillo, F. V., 1988, The mineral industry of Hawaii: U.S. Bureau of Mines, Hawaii Mineral Yearbook, 5 pp.
- Carithers, W., 1946, Pumice and pumicite occurrences of Washington: Division of Mines and Geology, Report of Investigations 15, 76 pp.
- Chesterman, C. W., 1956, Pumice, pumicite and volcanic cinders in California: Department of Natural Resources, Bulletin 174, 119 pp.
- Geitgey, R. P., 1992, Pumice in Oregon: Oregon Department of Geology and Mineral Industries, 26 pp.
- Hoffer, J. M., 1991, Pumice and pumicite in Arizona: Arizona Department of Mines and Mineral Resources, Open-file Report 91-8, 61 pp.
- Hoffer, J. M., 1993, Identifying acid-wash, stone-wash pumice: Textile Chemist and Colorist, v. 25, pp. 13-15.
- Hoffer, J. M., 1994, Pumice and pumicite in New Mexico: New Mexico Bureau of Mines and Mineral Resources, Bulletin 140, 23 pp.
- Horton, R. C., 1964, Pumice, pumicite, and volcanic cinder: Mineral and water resources of Nevada: Nevada Bureau of Mines and Geology, Bulletin 65, pp. 237-240.
- Player, C. M., and Strickland, L. W., 1995, Problems with electrolysis in garment-wet processing: Textile Chemist and Colorist, v. 27, pp. 23-26.
- Van Horn, R., 1964, Lightweight aggregate in mineral and water resources of Utah: Utah Geological and Mineralogical Survey, Bulletin 63, pp. 185-188.
- Williams, D. R., and Burgin, L., 1960, Pumice and pumicite: Colorado School of Mines, Mineral Industries Bulletin, v. 3, 12 pp.

# Brick tunnel-kiln thermal-energy inputs

George F. Cudahy<sup>1</sup> and George S. Austin<sup>2</sup>

<sup>1</sup>American Eagle Brick Company, P.O. Box 12786, El Paso, Texas 79913, USA

<sup>2</sup>New Mexico Bureau of Mines & Mineral Resources, New Mexico Tech, 801 Leroy Place, Socorro, New Mexico 87801-4796, USA

**Abstract**—The American Eagle Brick Company (AEBC) is in New Mexico just north of the New Mexico/Mexico Border, west of the Rio Grande, and west of El Paso, Texas. Marine shale and quartzose shaly siltstone of the Lower Cretaceous Mesilla Valley and Anapra Formations have been quarried for brick- and tile-making since 1897 by the El Paso Brick Company, now AEBC. Beehive or periodic kilns were last used in 1974 and have been replaced by a tunnel kiln. The present tunnel kiln has been continually upgraded in the 1990s.

European tunnel-kiln energy consumption standards of circa 1979 were approximately 1,100 Btu/lb of fired product, while today's modern European tunnel kilns are achieving energy efficiencies as low as 600 Btu/lb. In its circa 1974 tunnel kiln, AEBC presently consumes approximately 785 Btu/lb of fired product.

Research into methods of reducing AEBC's consumption in the existing kiln to the European standards is ongoing. Methods used to reduce the previous consumption from approximately 1,200 Btu/lb to today's 785 Btu/lb are improved longitudinal air flow through the brick stacks, reduced excess burner air, and digital temperature control. Procedures being considered include drying brick with exhaust gases, reducing or eliminating burner-air-heating requirements, and cold-air entrainment reduction. Additional energy consumption offsets attainable in a modern kiln, presently in the design stage, are enhanced wall insulation, kiln wall and undercar heat for drying, and undercar heating of cold entrained air.

## Consumo de energía termal en hornos de túnel para ladrillos

**Resumen**—Las instalaciones de *American Eagle Brick Company* (AEBC) se encuentran en Nuevo Mexico, casi sobre la frontera internacional con Mexico, al oeste del Rio Grande y de El Paso, Texas. Desde 1897, *El Paso Brick Company*, ahora AEBC, ha explotado esquistos arcillosos marinos y areniscas arcillosas siltíferas marinas de las Formaciones Mesilla Valley y Anapra del Cretácico Inferior para la fabricación de ladrillos y mosaicos. Hasta 1974 se usaron hornos tipo colmena (*beehive kilns*) u hornos periódicos (*periodic kilns*), los cuales fueron reemplazados en ese año por un horno de túnel. Desde 1990, la empresa lo ha venido modernizando.

Por el año 1979, el gasto normal de energía en los hornos europeos era de unas 1,100 Btu/lb (unidades térmicas británicas por libra), pero en hornos europeos modernos se están obteniendo eficiencias de hasta 600 Btu/lb. *American Eagle Brick Company* actualmente gasta unas 785 Btu/lb en su horno de túnel que data de 1974.

Se están desarrollando métodos para reducir el consumo térmico en el horno existente de *American Eagle Brick* a la norma europea actual. Métodos ya puestos en práctica son los siguientes: el ladrillo se seca con gases de escape; así se ha reducido o eliminado la demanda térmica de los quemadores precalentando el aire; se ha reducido el entrenamiento de aire frío. Medidas adicionales que se pusieron en práctica para reducir el consumo anterior de 1,200 Btu/lb a los 785 Btu/lb de ahora son las siguientes: se mejoró el flujo longitudinal de aire por entre las pilas de ladrillos; se redujo un excesivo suministro de aire a los quemadores; y se instalaron controles digitales de temperatura. Se espera ganar ahorros adicionales de energía en el diseño de un nuevo horno, como por ejemplo: refuerzos en la aislación de las paredes del horno; provisions para calentar las paredes del horno y la superficie inferior de los carros de transporte para un secado más eficaz del ladrillo y calentar el aire frío entrenado en la superficie inferior de los carros.

### Introduction

AEBC is in New Mexico on the east side of Cerro Cristo Rey in secs. 8, 9, 15, and 16 T29S R4E just north of the New Mexico/Mexico Border, west of the Rio Grande, and west of El Paso, Texas (Fig. 1). Marine shale and quartzose shaly siltstone of the Lower Cretaceous Mesilla Valley and Anapra Formations (Fig. 2) have been quarried for brick- and tile-making since 1897, first by the El Paso Brick Company, and now by AEBC. Just south of the border in Ciudad Juarez, also on the east side of Cerro Cristo Rey is another brick plant, Productos de Barro Industrializados, S.A.

Beehive or periodic kilns were last used by AEBC in 1974 and have been replaced by a tunnel kiln. The present tun-

nel kiln has been continually upgraded in the 1990s. Improvements in the kiln for efficiency, both in the past and contemplated for the future, are the subjects of this report.

### Geology

In AEBC pits on the east and north side of Cerro de Cristo Rey, Cretaceous sedimentary units have been folded and faulted because of the mid-Eocene Cerro de Cristo Rey andesite, locally known as the Muleros Andesite (Fig. 1). The underlying Mesilla Valley Formation is composed of two members: a lower black, shiny, carbonaceous shale, and an upper shale with interbeds of siltstone, fossiliferous limestone, and ironstone-ferruginous sandstone at the transitional zone with the overlying Anapra Formation

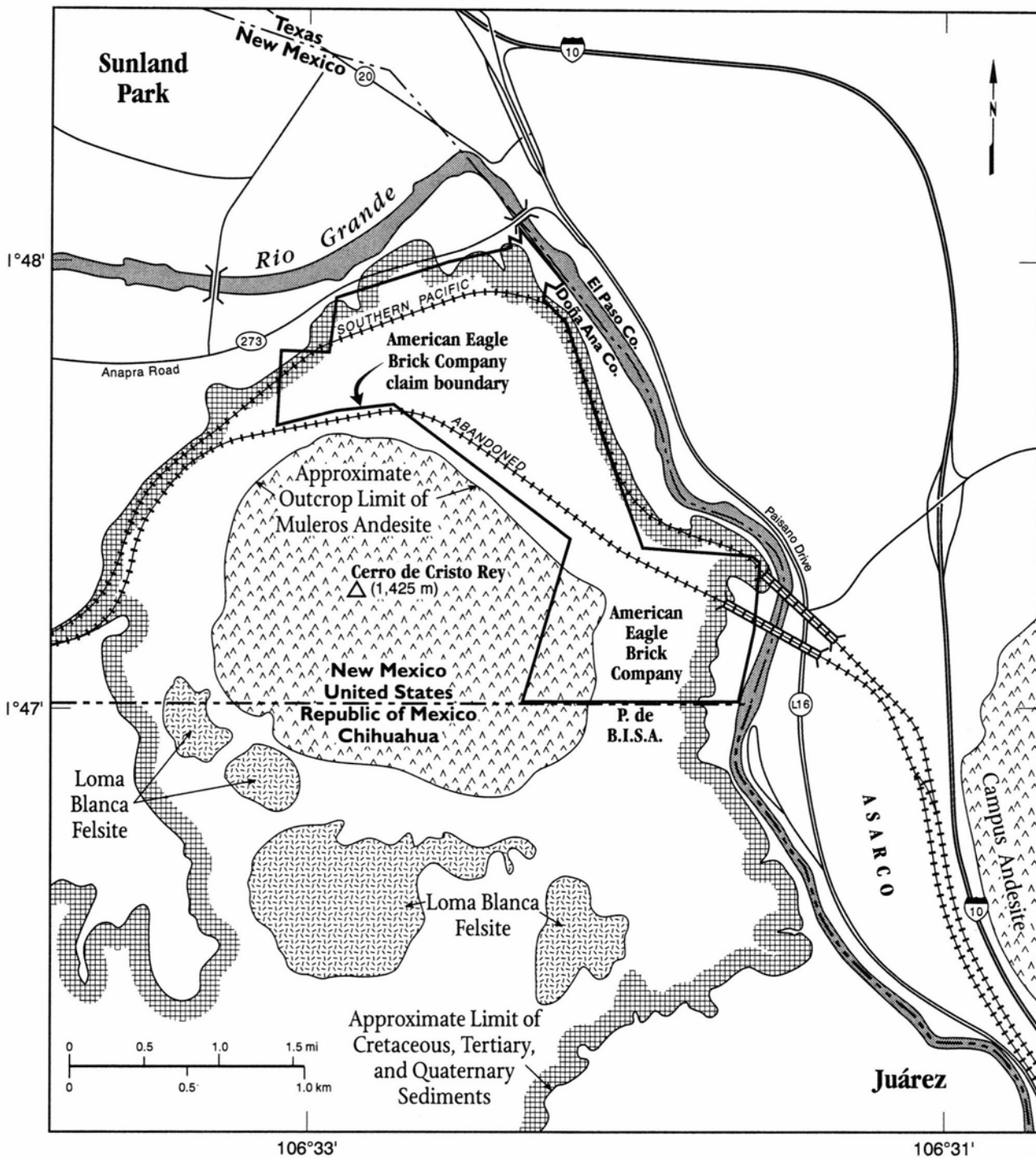

FIGURE 1—American Eagle Brick Company on the east and north flanks of Cerro de Cristo Rey in south-central New Mexico (modified from Ntsimanyana, 1990).

(Fig. 2). Only the lower member of the Mesilla Valley Formation is extensively quarried for use in brick production, especially where it lies close to the Muleros Andesite. The heat from the intrusion acted to accelerate the conversion of smectite to illite-smectite mixed-layer clay (I/S) to illite, and to produce additional kaolinite (Ntsimanyana, 1990). This process also reduced the concentrations of carbon, fluxing agents (K, Na, Ca, and Fe), and smectite. These reactions improve the firing properties of formations, especially the Mesilla Valley shale. Where Mesilla Valley shale is not proximal to the intrusive, firing properties are noticeably poorer and less uniform.

The Anapra Formation lies conformably on the upper Mesilla Valley ferruginous sandstone-siltstone interbeds (Fig. 2). The formation is primarily made up of quartz sandstone with interlamination of siliceous shale, which locally become carbonaceous. Strain (1976) and Ntsimanyana (1990) divided the formation into four members. Lovejoy (1976) identified five members, but the former classification is used because the four units are more readily identified in the vicinity of the AEBC pits. The lower sandstone member is about 65 ft thick (Strain, 1976) and contains thin- to massively bedded, quartzose sandstone interbedded with shale-siltstone. The overlying

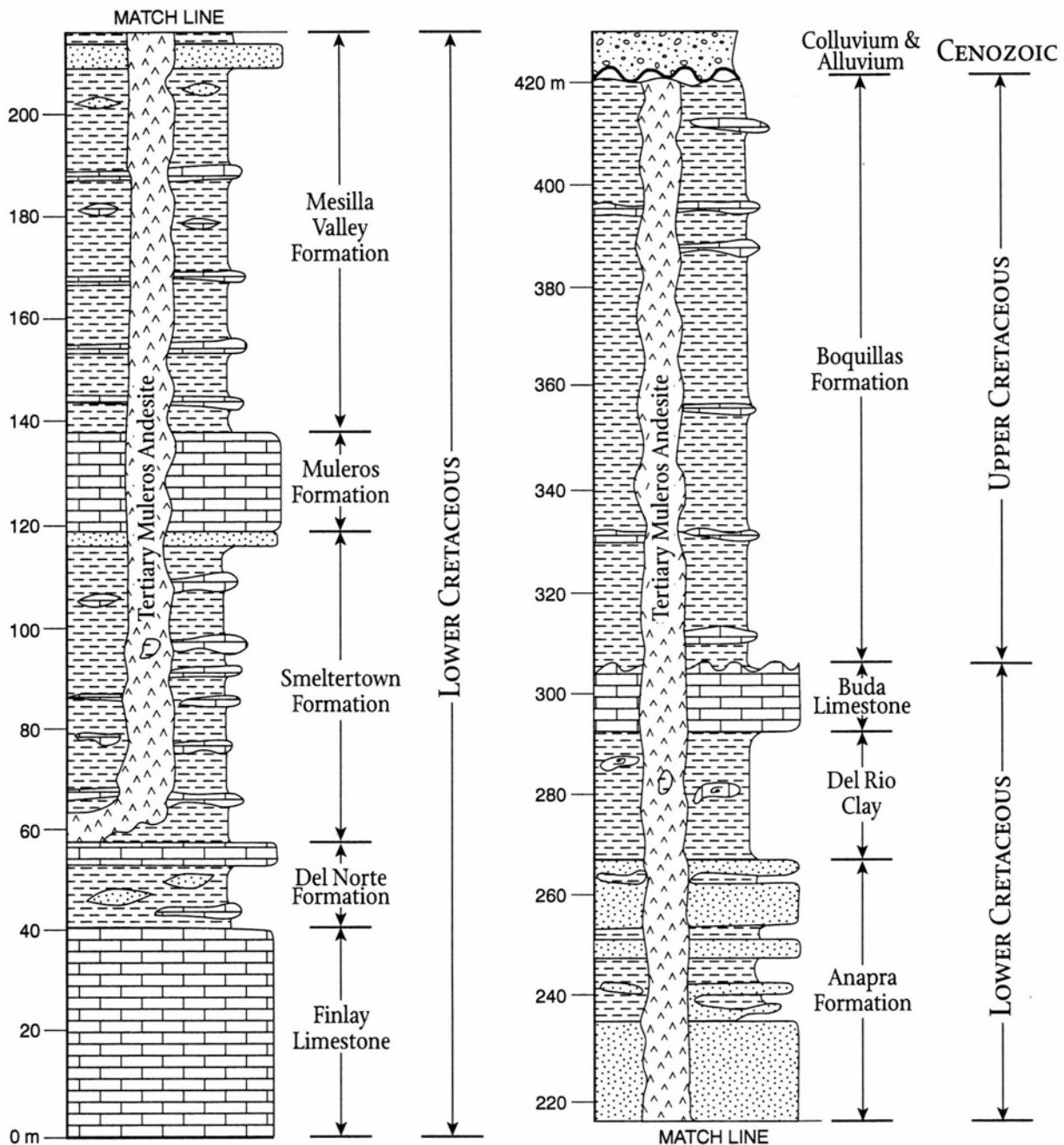

FIGURE 2—Cretaceous and Cenozoic strata exposed at Cerro de Cristo Rey, Dona Ana County, New Mexico (modified from Ntsimanyana, 1990; Lovejoy, 1976; A. Strain, 1976).

lower shale-siltstone member is the thickest shale-siltstone horizon in the Anapra, and has been measured as 46 ft thick (Ntsimanyana, 1990). The middle sandstone member is a light pink, quartzose, medium- to coarse-grained, slightly indurated sandstone. The thickness is variously reported as 12.5 ft (Strain, 1976) to 36 ft (Lovejoy, 1976). Overlying the middle sandstone, is the upper sandstone member with medium- to fine-grained sandstone interlayered with siliceous siltstone and shale. Its thickness varies from 49 to 79 ft (Strain, 1976). Shale and siltstone of the lower sandstone member, the lower shalesiltstone member, and the upper sandstone member are sources of material for the brick-making process, although the middle sandstone member is quarried for use as a flux by both AEBC and the nearby Asarco smelter that lies just east of the Rio Grande (Fig. 1). Of the four mem-

bers, the lower shale-siltstone member is the chief source of brick material because its thickness and lithologic character.

The constituent minerals of the Mesilla Valley and Anapra shales and siltstones are quartz, feldspar, illite, smectite, I/S, kaolinite, dickite, calcite, minor amounts of gypsum, minor to trace amounts of iron and titanium oxides, and carbon compounds. These constituents govern the ceramic properties of the clay material. Quartz, feldspar, and the phyllosilicates reorganize to form the bulk of the fired product. K, Na, Ca, Fe, and Mg in the feldspars, oxides, carbonates, sulfates, and carbonaceous matter act as fluxes that effect the "green" (before firing), firing, and post-firing properties. For instance, Na and Ca may influence the plasticity during molding. CaO effects the incipient melting temperature and the vitrifica-



lion range, and Fe effects the fired color (Grimshaw, 1971; Brownell, 1976).

**Brick kilns**

Two basic types of kilns have been used to fire brick: the periodic kiln and, more recently, the tunnel kiln. The periodic kiln has been used successfully for the past six thousand years and evolved from hand-loading of individual brick into the kiln, to loading brick on a car and shuttling the car into and out of the kiln (a shuttle kiln). The basic energy-consumption flaws of the periodic kiln are the lack of utilization of the fired brick's heat and the high gas-exhaust temperatures during the later firing stages. Another flaw is the time required to load, fire, cool, and unload a batch of brick. El Paso Brick Company, the previous owner of the AEBC property, used periodic beehive kilns that required two weeks of turn-around time for this operation, with a production rate of 4,000 brick/day/kiln. While the periodic kiln is still used by brick plants today in a limited way, the tunnel kiln dominates in U.S. and European fired-brick production. There are several advantages to the tunnel kiln in both energy utilization and productivity. With the clay presently used, AEBC's relatively small tunnel kiln produces 50,000 brick equivalents per day on a continuous basis and requires 785 Btu/lb of fired product to dry and fire the brick.

A tunnel kiln uses car loads of brick that enter the kiln from one end via a kiln-seal door. The gas flow in the kiln is counter to the brick flow (Fig. 3). The brick are moved into the kiln usually one half car per "push." The push-rate is dependent upon kiln length, car size, and

similar specifications. At AEBC the cars push at 18 half-cars per day. Each car has a 16 inch firing slot in the middle, the slot being normal to the direction of car movement. A firing slot of 16 inches is also formed between cars. Energy input is achieved by burners located at approximately mid-length on top of the kiln. The brick located between the firing zones and the kiln entrance are heated by the longitudinal gas flow through the kiln. The exhaust gas exits the kiln at a temperature slightly above the temperature of the entering brick. At AEBC the brick enters the kiln from the dryer at 250°F. The exhaust-gas temperature is 350°F. After the brick exit the firing zone, they are gradually cooled by air flowing into the kiln exit. Heated air is used to supply energy to the brick being fired; part is used to dry the brick in the dryer prior to entering the kiln. The brick exit the kiln at approximately 300°F after being fired at 1,900°F.

The purpose of this paper is twofold. We will examine the theoretical limits of energy consumption achievable in an actual kiln of approximately the size of AEBC's present kiln, compare that to the state-of-the-art in Europe in the mid-1970s and today, and examine AEBC's status today and its progress in the last five years. We next will discuss what can be done additionally in AEBC's circa 1974 kiln and explore how AEBC intends to push the state-of-the-art in future kilns.

**Theoretical limits of existing AEBC kiln**

The energy requirements of a kiln are for wall, roof, car-deck conductivity losses, exhaust-energy content, exit brick- and car-heat contents, burner-air energy require-

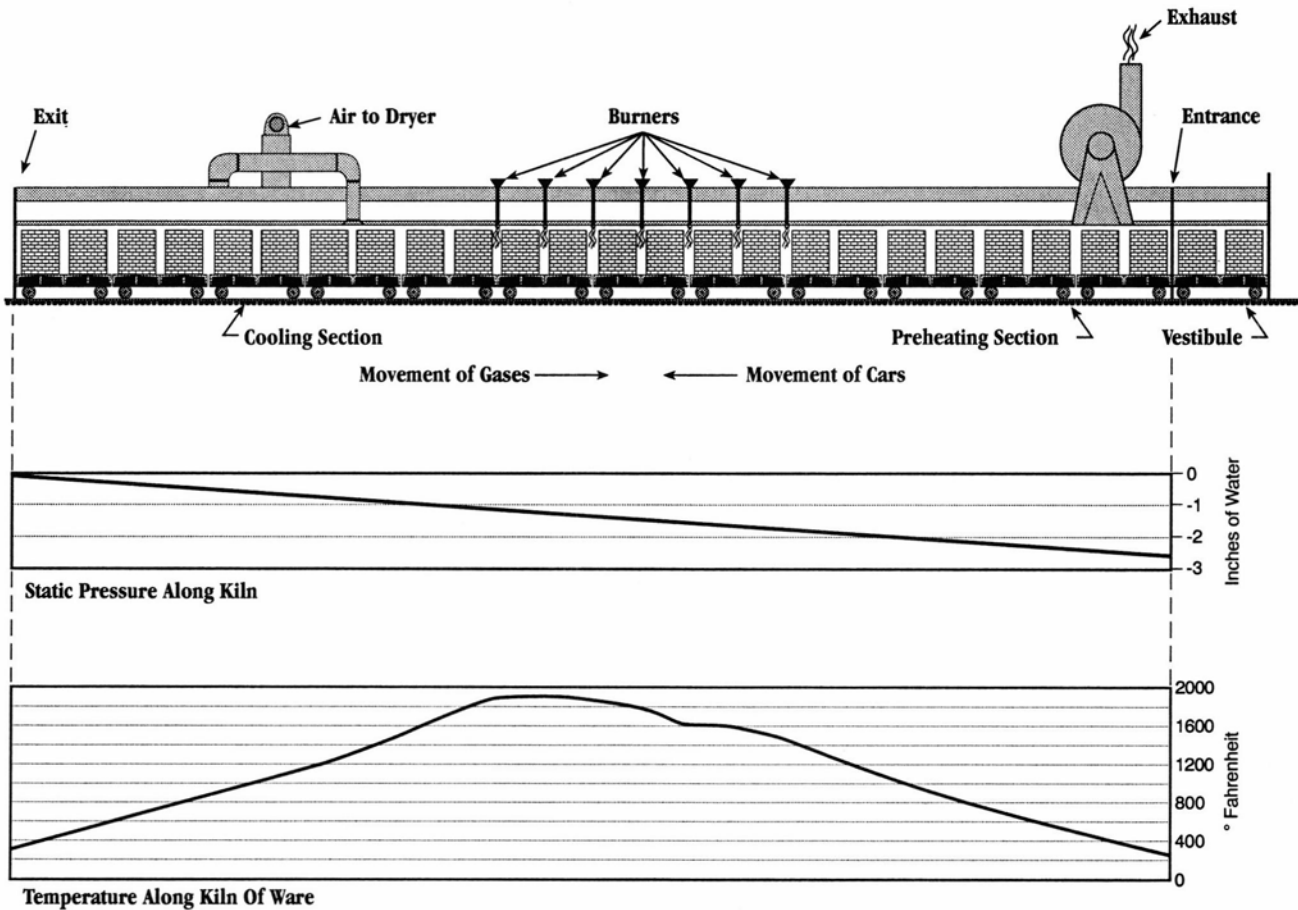

FIGURE 3—Side view of AEBC's direct-fired tunnel kiln illustrating the directions of movement for cars and gases with changes in temperature along the length of the kiln.

ments, brick-drying energy requirements, and endothermic and exothermic reactions. Energy losses because of air infiltration between car interfaces and around car sealing rails, air infiltration through the kiln ceiling and walls, and excess burner-air will not be considered as it is our goal to eliminate these losses. Even though eliminating all stoichiometric burner-air will be discussed, the energy required to heat that air will be included in the theoretical limit.

### Wall, roof, and car-deck conductivity

The kiln is 143 ft long by 5 ft high by 9 ft wide and the average temperature difference between interior and exterior walls/ceiling is 1,000°F. The average thermal conduction of 2 Btu in/ft<sup>2</sup>/°F/hr and 10 inch wall/ceiling thickness that yields: wall/ceiling conductivity = 13.0 million Btu/day (MMBtu/day). The car deck will be 9 inches thick and, with similar conductivity to the walls/ceiling but with  $\Delta T$  of 900°F, these parameters yield: car deck conductivity = 6.2 MMBtu/day.

### Exhaust thermal energy

Assuming a 7 lb/sec gas flow at 250°F above ambient the exhaust energy yields: exhaust thermal energy = 36.3 MMBtu/day.

### Brick/car exit thermal energy

185,000 lbs of brick per day and 40,000 lbs of car at  $c$  (specific heat) of 0.21 and  $\Delta T$  of 200° F is: brick car exit energy = 9.5 MMBtu/day.

### Burner-air-heating thermal energy

Assuming that 100 MMBtu/day is consumed in our theoretical kiln and a stoichiometric air/gas ratio with natural gas, exit yields: 24,000 Btu/lb =  $4.2 \times 10^3$  lb CH<sub>4</sub>/day. This requires about  $79.4 \times 10^3$  lb/day of air. Assuming an average  $c_p$  of 0.24 and an air average temperature in the burner zones of 1,700°F, the energy required to heat the stoichiometric air is: heat stoichiometric air = 30.5 MMBtu/day.

### Drying-air thermal energy

Assuming that the brick contain 10% free water upon entering the dryer and that they are to be heated from 100° to 300°F, the total energy to remove the water and heat the brick is: water heating and vaporization = 20.4 MMBtu/day and brick heating = 7.8 MMBtu/day. One half of the energy required can be obtained from the under car/wall ceiling losses and the other half from the cooling brick. The energy removed from the hot brick is: hot brick energy = 14.1 MMBtu/day.

### Endothermic and exothermic reactions and endothermic energy

Several endothermic and exothermic reactions take place during the heating and oxidation processes during brick firing and are dependent upon the clay being fired. For this theoretical analysis, the endothermic calcium/magnesium-carbonate decomposition and exothermic carbon oxidation relations for typical AEBC clay material were used. This material has the following average composition: CaCO<sub>3</sub> = 3.27%, organic carbon = 0.71%. The summation of these reaction amounts to about 12 MMBtu/day.

The heat of fusion is ignored because it assumed this energy is recovered during cool down. The total energy required is therefore approximately: 95.2 MMBtu/day.

and using 183,000 lb/day = 520 Btu/lb of brick.

If the energy removed from the hot brick during cool down for brick-drying could be replaced by another energy source such as the exhaust-gas energy of which there is more than a sufficient amount, then the thermal energy required (assuming that energy can be recovered in the firing zone) could be reduced to 443 Btu/lb of fired product. While this has been discussed in the literature, this approach has not been utilized because of chemical complications that might occur during the drying phase. These complications will be discussed under energy-reduction possibilities in a new kiln.

Another significant source of lower energy consumption would be the use of kiln air to provide the stoichiometric oxygen necessary for the natural-gas energy input. This approach is being seriously considered by AEBC and will be discussed in detail under proposed thermal input reductions in the present AEBC kiln. If sufficient oxygen exists in the kiln air flow to support complete combustion of the input natural gas and the other oxidation processes that take place in the kiln, with sufficient excess to compensate for incomplete mixing, then the energy required could be reduced from 520 Btu/lb to 353 Btu/lb of fired brick. However, the mechanism required to provide sufficient penetration of the input thermal energy in order to obtain a relatively uniform distribution across the entire brick-setting face exposed at the firing slots is not available.

### State-of-the-art and status of AEBC today

In the mid-to-late 1970s European brick kilns were using approximately 1,100 Btu/lb of fired product while the most modern kilns in Europe today are achieving thermal inputs as low as 540 Btu/lb. These kilns are quite large compared to AEBC's kiln, being twice as wide and two to three times as long. AEBC presently consumes approximately 785 Btu/lb of fired product in its circa 1974 German-designed kiln. When the plant was acquired by AEBC in 1990, the energy input required was 1,200 Btu/lb. Today's energy input (Btu/lb) includes the endothermic and exothermic reactions discussed earlier. This reduction was achieved in a number of ways. However, attempting to assign a contribution by each step would be highly inaccurate because often several changes were made simultaneously (including changes in the clay material composition).

AEBC's burner section consists of seven rows of burners with four burners per row. The first row cycles at 1,500°F and the last two rows cycle at 1,900°F. Because of a lack of understanding of the fluid flow taking place in the kiln, the oxidation processes underway in the brick, and the heat transfer processes required, the kiln burners were operated initially with the maximum excess air available (air valves wide open) during natural-gas input. In addition, the automatic air valves used to cut off air flow during burner off-cycle and kiln-push were disconnected to allow the full available air at 100°F to be delivered to all burners (excepting row 1) at all times. The first change made was to reactivate row 3 to 7 automatic air valves and to reduce the air to rows 2 to 7 to just "blow the flames out" at the burner. Because of the relatively narrow firing range, it was assumed at the time that the brick could not take the stoichiometric flame steadily impinging on a localized area on the firing slot brick face. There was some merit to this assumption at the higher temperatures because of a lack of sufficient oxidation of the carbon and sulfur in the brick up to that

time. The next step was to enhance oxidation and calcium carbonate decomposition prior to onset of exterior vitrification and sealing the brick surface. Burner row 2 was set at 1,650°F and row 3 was set at 1,700°F to give the one-half car between these two firing zones 80 minutes at that temperature range that yields anomalous oxidation if sufficient oxygen is present. This is also in the temperature range for decomposition of calcium carbonate. These changes yielded significant energy reduction and improved the carbon/sulfur oxidation.

Next, the brick setting was improved. Because of the extremely large excess air being pumped into the kiln at the burners and the lack of sufficient longitudinal openings in the brick package on the car, insufficient air flowed through the brick as they traveled toward the exit from the burner section. The result was excessively hot brick exiting the kiln. The brick were so hot that the center of each half-car of brick glowed red as the car exited the kiln. One could hear micro cracks being created in the brick as it rapidly cooled through the quartz-transition temperature range. The reduction of some of the excess air at the burner section improved the pressure gradient from the exit to the burner section, but the air pathways had to be improved. This was accomplished without reducing the number of brick on the car. The previous settings had equal openings in the package transverse direction as well as the longitudinal direction. Because transverse openings contribute little to heat transfer down the kiln, these openings were reduced and the longitudinal opening area was increased to approximately 25% of the face area. Later, another layer of brick was added to the top of the package to reduce the area above in order to force more air through the package center. This step contributed to further thermal input reduction and further enhanced the oxidation process. One can now place a hand on the exterior of the brick-package face after it exits the kiln and microcracking has, as far as we can tell, been eliminated.

As optimization progressed, AEBC was able gradually to reduce the excess air at the burners. All burners now have flame and are close to stoichiometric. The firing range of the brick was increased by enhanced oxidation of the carbon/sulfur in the brick, which allows the brick to achieve higher temperatures without bloating due to gasification of ferrous sulfate.

Additional small improvements were made including better sealing of kiln walls and ceiling, elimination of the "rapid cool" ports, increased insulation of the ceiling, improved sealing on the kiln entrance, and more closely controlling burner-section temperature via digital temperature controllers.

### Possible improvements in AEBC's kiln

**Items** are being considered for further reducing the thermal input required in the present kiln. These include reduction of infiltration air from under the kiln cars to the hot products, elimination of burner air, and the redesign and rebuilding of car decks to increase insulation and to further open longitudinal airflow passages.

#### Infiltration air reduction

Energy loss because of infiltration of cold air through the sand-sealing system is about 16 MMBtu/day. This is based upon an average pressure differential of 0.1 inch H<sub>2</sub>O for one half the kiln length and an open area along the 143 ft of car rails and the car-to-car interface of 0.8 ft<sup>2</sup>.

Eliminating this leakage would reduce the present consumption from 785 to about 700 Btu/lb of fired product.

The problem of air infiltration along kiln-car rails has been examined over the years and the most effective, yet somewhat complex, solution to date is the immersion of the car rails in water, and in some cases, the forward and rear car skirts. The latter is achieved by having the entire kiln base and the entrance and exit areas in a water trough. The former can be achieved by lowering the car into the kiln entrance and lifting it out at the exit so as to immerse only the rails in the water trough. A recent patent by Hans Lingl Anlangenbau and Verfahrenstechnik GmbH & Co. (United States Patent No. 4,744,750) proposes forming dry lateral seals at the car's leading and trailing edges while continuing to use sand seals at the rails. This latter method would be effective if the transverse seals could maintain closure over at least one year of continuous operation.

For reduction of air infiltration, the standard practice in most tunnel kilns is to close the exit end of the kiln and provide a slight pressure at the kiln exit end via an air fan (Fig. 3). The pressure is adjusted to obtain a neutral pressure at the burner section. This approach causes exfiltration (i.e. kiln atmosphere gases leaking around the sealing rails to the undercar area) in the latter half of the kiln where undercar cooling is most critical, but it does reduce infiltration in the leading half of the kiln.

We propose a different approach to the problem. Because the undercar lateral skirts do provide some restrictions to longitudinal air flow and can be modified to add additional restriction, it may be possible to closely match the kiln interior-pressure profile under the cars. Attention must be paid to the effect on the kiln interior-pressure profile by the hot-air extraction for the dryer, the air input at the burner section, as well as the pressure at the kiln entrance caused by the exhaust fan. Because individual cars of brick are loaded into a closed vestibule prior to being automatically pushed into the kiln, this vestibule may be sealed from the ambient atmosphere. Properly sized openings would be made in the kiln entrance door, such that the bottom of the kiln car at the kiln entrance has the same pressure as the kiln interior at the entrance. Baffles may then be judiciously placed on the kiln floor to approximately match the pressure profile from the kiln entrance to the exit.

Two additional benefits would accrue from this approach besides the relative simplicity of the mechanization. First, the undercar cooling required in the later half of the kiln would be enhanced without the use of undercar cooling fans. Second, the heat added to the undercar longitudinal air flow would aid in keeping the brick in the vestibule warm prior to entrance into the kiln (the brick presently are slightly cooled, which is undesirable). The only complication with this approach is ensuring that the hydraulic ram used to push the cars, located under the cars in the vestibule and kiln entrance, is cooled to prevent overheating of the mechanism and the oil.

#### Elimination of burner air

At a thermal energy input of 650 Btu/lb of natural gas, 0.71% organic carbon and 0.67% sulfur in the brick requires, for stoichiometric reaction, 0.29 lb of oxygen/second. Effective oxidation of the carbon and sulfur in the brick is enhanced by 100% excess oxygen in the kiln atmosphere. To ensure complete oxidation of the natural gas, oxygen is required at 200% of stoichiometric and re-

quires 2.74 lb of air/second. It is estimated that 7.0 lb of air/second is presently flowing in the kiln. An examination of the exhaust gases at the AEBC kiln supports this and leads to the conclusion that sufficient excess oxygen is available in the kiln atmosphere to completely react the burner gas without any additional air being introduced. However, a method must be developed to inject the gas into the kiln with sufficient velocity and mass to penetrate to the car decks over a distance in excess of 5 ft. We have two proposals to accomplish this. One is to have sufficiently large gas nozzles (0.25 inches in diameter) with Mach 1 exit velocities and to pulse the gas input such that the on/ off ratio times of the pulse input approximates the average thermal-energy input required. Since this inputs up to five times the average energy required during any one pulse, the row-to-row pulses must be carefully timed so as not to get overlap of one row's gas-air mixture with another thus depleting the oxygen available to less than required. This limits the numbers of rows, that can use pulse-burning of this nature. While a digital sequence timer has been built, there is concern that the electromagnetic gas valves will not withstand the very high frequency of operation—approximately six million per year.

The second proposal calls for low-velocity continuous gas injection with an air-cooled fan in each burner tube, recirculating kiln atmosphere hot gases with sufficient velocity to penetrate to the kiln cars. This method would give a modest  $\Delta T$  over the brick temperature and alleviate hot spots on the brick-package faces.

Both of these methods have significant drawbacks. The quest for a reliable method to eliminate burner air will continue because this approach has the potential of reducing the thermal input by 143 Btu/lb of fired product. The implementation of airless burner operation and air-infiltration reduction together shows the possibility of reducing the local thermal-energy requirements to 555 Btu/lb of fired product, which is the state-of-the-art value of modern brick kilns.

#### A new kiln

AEBC is planning to construct a modern kiln using a double-steel shell, cast-side insulation, and soft-insulation ceiling. The new kiln will implement all of the improvements discussed earlier, plus a new approach for obtaining brick-drying energy. Air will be drawn under the cars to variable openings on the side of the kiln, then through the double-shell sides and roof with collection along the center of the top of the brick. This will provide sufficient hot air for the initial drying of the brick. The openings under the cars through the sides of the kiln will be adjusted so the pressure under the cars closely matches

the localized pressures in the kiln interior, thus eliminating cold-air infiltration.

AEBC plans to test the use of exhaust gases to complete the final stages of drying. The critical feature of exhaust-gas drying is the complete absence of sulfur dioxide in the exhaust gas. Sulfur dioxide gases impinging on moist brick containing calcium and magnesium produce calcium and magnesium sulfates, which forms an undesirable white scum on the brick faces. With the help of Los Alamos Scientific Laboratory, the kiln stack gases of AEBC's kiln have been examined for sulfurous gases, and none have been detected to date. We believe the calcium carbonate contained in the brick reacts with the sulfur during the firing process producing calcium sulfate that remains locked in the brick. It appears the calcium carbonate, which is in excess as compared to the sulfur, acts as an internal scrubber of the reactive gases in the brick. This theory will be further evaluated and tests using the kiln exhaust to dry the brick in the late stages of drying (above 200°F) will be conducted. If the extraction of heat from the hot brick in the kiln for drying can be eliminated and the aforementioned improvements are implemented in the new kiln, together with other small improvements, it appears likely that the new kiln will be able to consume less than 500 Btu/lb of brick, much less than the most modern kilns presently in operation.

#### Conclusion

By applying innovative energy reduction techniques, it appears possible for older kilns to approach the energy consumption of the modern kilns in operation in Europe today and to lead the state-of-the-art by using those techniques when designing and building new kilns.

#### References

- Brownell, W. E., 1976, Structural clay products: Springer-Verlag, Wien, New York, 232 pp.
- Grimshaw, R. W., 1971, The physics and chemistry of clays, 4th ed., rev.: TechBooks, Fairfax, Virginia, 1024 pp.
- Lovejoy, E. M. P., 1976, Geology of Cerro de Cristo Rey uplift, Chihuahua and New Mexico: New Mexico Bureau of Mines and Mineral Resources, Memoir 31, 84 pp.
- Norton, F. H., 1974, Elements of ceramics, 2nd ed.: Addison-Wesley Publishing Co., Reading, Massachusetts, 311 pp.
- Ntsimanyana, M., 1990, Mineralogy and exploitation of the Anapra and Mesilla Valley Formations for the production of brick and tile, Anapra, Doña Ana County, New Mexico: Unpublished MS thesis, University of Texas (El Paso), 186 pp.
- Strain, W. A., 1976, Appendix 2—New formation names in the Cretaceous at Cerro Cristo Rey, Doña Ana County, New Mexico; in Lovejoy, E. M. P., Geology of Cerro de Cristo Rey uplift, Chihuahua and New Mexico: New Mexico Bureau of Mines and Mineral Resources, Memoir 31, pp. 77-82



# Value added—Refractory dolomite, a case study

David A. Hopkins

*Manager of Natural Resources, Baker Refractories Company, 320 North Baker Road, York, Pennsylvania 17404, USA*

**Abstract**—Much of dolomite produced in the United States is typically used as a construction aggregate, where little value is added to the material mined. Dolomite mined by the Baker Refractories Company in York, Pennsylvania, has a unique combination of both chemical and physical characteristics that allows it to be manufactured into a wide variety of valuable refractory products.

The manufacturing process begins with highly selective mining and progresses through the various crushing and screening circuits required to yield a feed for the rotary kilns. The dolomite is then sintered at very high temperatures to yield a refractory grain of high density and purity. This refractory grain is then crushed, milled, sized, and delivered to either the refractory brick plant or the specialties plant. At the brick plant the refractory grain is mixed, pressed, fired or tempered, and packaged for worldwide distribution.

Many steps are involved in the production of refractory brick or other refractory products. Each of these steps should be adding value to the final product. The problem is to insure that the added value exceeds the added cost.

## Valor agregado- Dolomita refractaria, un estudio de aplicación

**Resumen**—Uso típico para gran parte de la dolomita producida en los E.U.A. es para agregado de construcción, por lo cual es poco que se incrementa el valor económico del producto en bocamina. La dolomita explotada por *Baker Refractories Company* en York, Pennsylvania, posee una combinación única de características tanto químicas como físicas que permiten su aplicación en una variedad de productos refractarios de valor.

El proceso de manufactura empieza con una extracción altamente selectiva en la cantera, y progresa por varios circuitos de molienda y selección requeridos para preparar el material para los hornos rotatorios. La dolomita es fundida a elevadas temperaturas que producen un grano refractario de alta densidad y pureza. Este grano refractario luego es triturado, molido, clasificado por tamaño de grano y luego transportado sea a la planta de ladrillos refractarios o Bien a la planta de productos especiales. En la planta de ladrillos, el grano refractario es mezclado, comprimido, horneado o templado y luego embalado para su distribución mundial.

Se requieren muchas etapas para la producción de ladrillo y otros productos refractarios. Cada una de esas etapas debiera agregar valor al producto final. El problema es hacer cierto que el valor agregado es mayor que el costo agregado.

### Introduction

Dolomite is a double carbonate of calcium and magnesium,  $\text{CaMg}(\text{CO}_3)_2$ . The name can refer to both the mineral and the rock that contains a large percentage of the mineral. The rock dolomite usually contains some impurities. These impurities are typically silica, alumina, iron, manganese, sulfur, and phosphorus. The level and type of impurities can be critical to the end use of the dolomite. Dolomite that is used for refractory purposes is usually of high purity. High-purity dolomite is normally considered to contain a minimum of 42%  $\text{MgCO}_3$  and a maximum of 2% total impurities.

Dolomite is a relatively common sedimentary rock. Large volumes of dolomite are produced annually in the United States (over 60 million tons). The degree of processing that a dolomite undergoes is usually directly related to its intended end use. Much of the dolomite mined is utilized for construction aggregate. Construction aggregate typically undergoes only mining, crushing, and screening, and sells for a relatively low unit price. If a dolomite is to be used in a product that requires very exact chemical and physical properties, several more steps (and costs) are added to its production. The example presented here is dolomite used in the production of high-purity refractories, for which additional steps actually

start before mining. The production of a high-purity refractory-grade dolomite can require extensive exploration of the deposit.

### Baker Refractories at York, Pennsylvania

The deposit mined by Baker Refractories is geologically complex and requires close-spaced diamond-core drilling for proper reserve determination and production planning. The drilling presents an added cost, but the information gained is essential.

The mining of high-purity dolomite also usually incurs a higher cost, because in many instances selective mining is required. This cost depends on the geologic complexity of the deposit and on the amount of selectivity and blending required. This is also true for the Baker Refractories Company. Three grades of dolomite are produced from the Baker deposit. The highest grade dolomite is used in the production of refractories. The middle-grade dolomite is used to produce a dead-burned dolomite, and the lowest grade dolomite is used to produce agricultural lime, mineral fillers, and aggregate.

In order to insure that only the proper quality of dolomite is being produced, an intensive quality control program is required. This also comes at a higher cost than what would be required for the production of construc-

lion aggregates. The quality-control cost compounds itself as the quality is checked during each step in the process. Those that have been involved in securing ISO Certification know the importance that is placed on quality checks, documentation, and traceability (Editor's note: *see* Holmes, this volume). At the Baker Quarry these checks begin with the diamond-core drilling and progress through blasthole-cuttings sampling, quarry-shot sampling, sampling of sized dolomite as it is being binned, and sampling of dolomite as it exits the bins and is fed to the rotary kilns.

Even though dolomite used for construction aggregate initially undergoes the same processing as dolomite used in the production of refractories (mining, crushing, and screening), factors related to insuring the quality of the refractory dolomite have pushed its cost of production well above that of construction aggregate. After this degree of processing, the construction aggregate is ready for sale to the consumer. The refractory-grade dolomite, on the other hand, has just begun its journey through the system.

After crushing and screening, the next major step in the production of a dolomite refractory is calcination of the dolomite at an elevated temperature. This process drives off carbon dioxide and recrystallizes the dolomite into a mixture of magnesium and calcium oxides. When burned at a high enough temperature, the dolomite forms a high-density grain that has a very high melting point (a refractory). The calcining of refractory dolomite is usually completed in a rotary kiln. Some companies that produce a refractory dolomite must use a double-burn process, which adds several costly steps. In a double-burn process the dolomite is first lightly calcined in a rotary kiln to produce dolomitic lime. This lime is then milled, briquetted, and then burned again in a rotary kiln at a high temperature to produce a high-density refractory grain. Due to a unique combination of chemical and physical characteristics, the Baker dolomite can be burned to the proper density in only a single pass through a rotary kiln. This allows the Baker Company to avoid the additional expense of the milling and briquetting equipment and the cost of the second burn. Extra kiln capacity is also gained by not having to double-burn.

Baker Refractories has two rotary kilns on site, both 300 ft long. The primary product from the rotary kilns is the refractory grain that is used to manufacture refractory brick and specialties. The kilns are also used to produce a dead-burned dolomite (trade name *Magdolite*). This is manufactured from the middle-grade dolomite and has iron added during the firing process.

The temperatures required to produce grain with the proper specifications are quite high. This is a very costly step which increases the value of the product substantially.

The refractory grain produced in the rotary kiln passes through a cooler and is then stored in bins prior to starting the next step in the process. The grain is transferred to a sizing plant where all size fractions required for the various refractory products are obtained. This plant contains crushing, milling, and sizing equipment. The products from this plant can be delivered to either the refractory specialties plant or to the refractory brick plant. At the specialties plant the grain is combined with a variety of additives and binders to produce gunning mixes, ramming mixes, mortars, and other non-shaped refractory products.

Most of the refractory grain is transferred to the refractory brick plant, where the grain is first placed into a mixer. A computer controls the volume of the different

size fractions of refractory grain, along with binders and additives. The mixed batch is then delivered to a holding mixer at the presses. A variety of presses is used to form the mixture into a "green" brick shape. After pressing, bricks are placed either on a kiln car (if they are to be ceramically bonded in a tunnel kiln or periodic kiln) or on racks (if they are resin-bonded brick and require tempering in an oven). An extensive computer-aided quality-control program is utilized to insure that all the various sizes of brick meet very exact specifications.

The bonding of the brick is another very costly step in the process. Resin-bonded bricks are heated to a moderate temperature to set the resin. Ceramically bonded bricks are heated to high temperatures in gas-fired kilns.

After cooling, all bricks are stacked on pallets for additional processing and inspection. Additional processing may include adding thermal expansion strips, laser controlled size checks, and dipping. A robot then stacks the bricks on pallets for packaging. Since dolomite refractories can rehydrate if exposed to atmospheric moisture, special packaging in a climate-controlled area is employed.

### Baker Refractories in the world marketplace

An often overlooked factor that adds substantial cost to just about every additional process step is the ever increasing cost of environmental compliance. The cost of obtaining and maintaining surface mining, NPDES (National Pollutant Discharge Elimination System), air quality and solid-waste permits, the cost of pollution-control equipment, emission fees, waste disposal, and air and water monitoring all add greatly to the cost of the product without adding anything to its value. This is a serious and important factor, considering that the product must compete in a global market place.

Baker Refractories ships its product worldwide. Currently about one-third of the plant production is exported. Most of the products from both the brick and specialties plants are used in the steel and cement industries, e.g. for lining steel ladles and furnaces, and burning and transition zones in rotary cement kilns.

As can be seen, there are many complex and costly steps in the production of refractory-dolomite brick and other refractory products. Ideally, each of the many steps that the material undergoes should be adding value to the product. The problem is that each step is also adding substantial cost. The trick to this highly competitive industry, where price increases have been non-existent for many years, is to make sure that the added value exceeds the added cost by at least a small amount.

### Conclusions

The Baker Refractories Company had its beginnings in 1889 as the Wrightsville Lime Company supplying lime from shaft kilns to local farmers. The company now supplies high value refractories from three production facilities: York, Pennsylvania; Worksop, England; and Monterrey, Mexico. The company employs approximately 1,100 people and is the second largest supplier of dolomite refractories in the world. The foundation of the company continues to be the common rock called dolomite. The Baker Refractories Company takes this common rock and processes it on-site to manufacture a product that will sell for approximately 100 times the price of aggregate made from the same material. **THAT'S VALUE ADDED!!**



# Industrial mineral operations— Tying ISO 9000 to geology and reserve management

David A. Holmes

*Bebre Dolbear & Co. Inc., 1601 Blake Street, Suite 301, Denver, Colorado 80202, USA*

**Abstract**—ISO 9000 certification benefits mineral operations in four ways: (1) by gaining the operator valuable marketing and sales status as a certified source of high-quality products, (2) by improving or enhancing Total Quality Management (TQM) within their operations, (3) by improving their competitiveness, and (4) by gaining a realistic overview of their entire operation. Many operators include processing and product handling/sales functions within their certification, but exclude the mining operations, considering them essentially as outside suppliers. Whether or not mining functions are included, certified operators must still audit the quality performance of their raw material sources including captive mines. Sound knowledge of the geology of their deposit(s) and the minable reserve framework therein deliver to an auditing operator strong tools to use in improving plant feed grade/quality consistency and in estimating mine life.

## Operaciones de industria mineral—ligando la certificación ISO 9000 con la geología económica y el manejo de reservas

**Resumen**—La certificación ISO 9000 (establecida por *International Organization for Standardization*, Ginebra, Suiza) beneficia las operaciones minerales de cuatro modos: (1) confiere al operador una categoría de prestigio en la comercialización y ventas como proveedor acreditado de productos de alta calidad, (2) dentro de la operación misma mejora o acentúa un Manejo de Calidad Integral (*Total Quality Management (TQM)*), (3) incrementa la capacidad de competir en el mercado, y (4) asiste en ganar una perspectiva realista de toda la operación. Muchos operadores incluyen la elaboración, el manejo y la venta de sus productos en la certificación, pero excluyen las operaciones de minería porque las consideran proveedores externos. Pero si el operador incluye o no las funciones mineras, la certificación impone a sus operadores acreditados la responsabilidad de fiscalizar la calidad de producción de sus fuentes de materia prima inclusive las operaciones de minas dependientes. Un conocimiento sólido de la geología de los yacimientos y sus reservas explotables le confieren al operador fiscalizador medios efectivos para mejorar la clasificación y consistente calidad de la materia prima, así como una estimación de la vida del yacimiento.

### Introduction

ISO 9000 remains a puzzle to most Americans today, who at best believe that it is just another trendy quality bureaucracy on the business scene. Most of us have been blitzed with management and quality program acronyms over the past 30 years: QC, the Deming Method, SQC, QA, QMI, QMS, TQM, QMA, MBNQA, and on and on.

ISO is an acronym for the International Organization for Standardization, which is based in Geneva, Switzerland and has over 90 member countries. It was founded in 1946 to develop operating standards for manufacturing, trade, and communications. The American National Standards Institute (ANSI), based in New York City, is the United States representative of ISO, and acts as the certifying body for the ISO 9000 program in this country. ANSI works closely with the American Society for Quality Control (ASQC), based in Milwaukee, Wisconsin, in providing technical and educational support on ISO 9000 and other quality concerns within the United States.

The 90 member countries have each adopted ISO 9000 quality management systems. Some countries have put the standards into their own numbering system, but the contents are identical to ISO 9000. About 60,000 companies are ISO-certified worldwide, including 5,000 companies in the United States.

The ISO 9000 program is a comprehensive, documented system that links process functions together. A key objective of ISO 9000 is to build quality into the total system. ISO 9000 provides an internationally common language to evaluate quality standards.

In 1987, ISO published its ISO 9000 Series of International Standards. This set of generic standards provides guidance for quality management and quality assurance. Registration is done on a plant/ facility basis, not a corporate basis.

Most mineral operations in corporate North America today employ some kind of quality management system that is concerned with Quality Assurance related to the quality of their products. ISO 9000 deals primarily with the quality of performance by the producer or server institution, how consistently and well they function rather than the direct quality of their products.

One should think of ISO 9000 as similar to an on-going cardiac evaluation and marathon treadmill test in which a medical system continuously measures the level of performance of the heart and circulatory system, not the quality of the blood that the system transports throughout the body. A certified sound heart and arterial/venous system does not mean that the blood itself is of good quality, full of nutrients, and free of naughty things.

### Background on quality management

A "Quality Management System" seeks to ensure that the best practices are adopted by a producer so that the end product will be right the first time. Quality here does not relate to the integral quality of the end product, but rather to maintaining the best possible methods and attitudes in production so that there are as few flaws as possible in the product.

While we are talking about the fundamentals of the quality world, three basic definitions are critical: **Quality Control (QC)**—The operational techniques and activities that are used to fulfill requirements for quality. **Quality Assurance (QA)**—All the planned and systematic activities, implemented within the quality system and demonstrated as needed, to provide adequate confidence that an entity will fulfill requirements for quality. **Total Quality Management (TQM)**—The management approach of an organization that is centered on quality. It is based on the participation of all its members, and aims at long-term success through customer satisfaction and a providing benefits to the members of the organization and to society.

ISO 9000 does not replace QC or QA programs; it demands that they exist and be functioning effectively. ISO 9000 does not replace more complex QA systems such as TQM, it supports them and demands management adherence to their principles.

#### What ISO 9000 is

ISO 9000 is a quality system standard that was created by the International Organization for Standardization (ISO), based in Geneva, Switzerland. The organization comprised of more than 90 national standards bodies each representing a different country. The member body representing the United States is the American National Standards Institute (ANSI).

ISO 9000 is the approved quality system standard for most of the world's industrialized nations. Born in talk on strategies to bring a common system of quality standards to the European Union (EU), it now embraces industry widely in the EU and is growing rapidly in North America and the Far East.

ISO 9000 is a series of standards on QA and quality management that apply to the processes which create products or services. ISO 9000 certification is granted on the basis of achievement of a high level of quality standards and is maintained on the basis of a high level of performance under these standards, verified by ISO 9000 audit. The standards are generic and can be used by manufacturing and service industries all over the world. The goal behind the development of ISO 9000 is to simplify the international exchange of goods and services by developing a common set of quality standards. It is directed at QA, not QC principles. The ISO 9000 standards describe the minimum quality requirements for a quality system.

ISO is a system of common sense values and practices that govern how facilities manage their quality and other systems. It applies not only to manufacturing operations and their products, but to services in hospitals, law firms, government agencies, and other facilities as well. Some federal government agencies employing it include: Department of Defense, Office of Personnel Management, and the General Services Administration.

#### What ISO 9000 is not

ISO 9000 is not a trade association or public relations body that grants certification or registration to compa-

nies because they look good, try hard, belong to certain political groups or industries, or make major contributions to any specific cause. ISO 9000 standards are not specific to the relative quality of services or products, as that role is more appropriately held by consumer groups, trade associations, and others. ISO 9000 is not a government agency or system, although it has close ties to the European Union governing body and a close affinity to the U.S. Department of Defense and certain other agencies.

#### How ISO 9000 works

In progressing through the steps toward ISO 9000 registration/certification, a company must thoroughly examine its practices and procedures, write its own formal Operating Manual, undergo extensive self and third-party auditing, and essentially retrain its managers and workers. It must clearly define management responsibility and lay out firm plans for how the company is going to operate in the future. It must essentially build a new "Quality Management System."

After this Quality Management System is emplaced, the registered facility operates thereafter with the new QMS as its guiding force. Day-to-day actions undertaken are monitored. "Corrective Actions" are taken to solve the problems that arise and to return operations to their planned course. Documentation is kept that meticulously tracks the progress of the whole venture. In summary, the ISO 9000 program can be defined by its five basic principles: (1) management responsibility, (2) planning (includes construction of a corporate procedure manual geared to ISO 9000), (3) monitoring, (4) corrective action, and (5) documentation.

Compared to other quality systems, ISO 9000 deals in objectives while others deal in methods. ISO 9000 deals in principles, while others deal in procedures.

#### Which is it?—ISO registration or ISO certification?

According to "The ISO Handbook," published by CEEM Information Services, the terms "certification" and "registration" are commonly used interchangeably, although they are slightly different steps in the same process. The preferred U.S. terminology is "quality system registration," while in Europe "quality systems certification" is more widely used.

Further, according to CEEM, the EU has adopted the ISO 9000 series as part of its conformity assessment plan to establish uniform systems for product certification and quality system registration. "Registration" involves the audit and approval of a quality system against ISO 9001, ISO 9002, or ISO 9003 by an accredited independent organization, also known as a "third party registrar."

#### Mining companies and ISO certification

Traditional American mining companies were late in joining the world of ISO registration. Those selling directly into commodity or regional markets have not felt the marketing or customer pressure to be registered; the industry has run well for many decades with established practices and targeted its sales toward satisfying basic specifications for its commodity products. Quality philosophy lay perhaps between: "Good enough is good enough," and "You meet the specs, you make the money."

With time, three other factors have come into play: (1) some European and other customers have insisted that suppliers be ISO-certified, or otherwise, at least, subject

to frequent quality audits with the constant threat of rejection; (2) competitors have become ISO registered, and gained a preferential status in the markets compared to non-registered companies; and (3) companies with more complex products, such as specialty clays, refined-chemical mineral products, high-quality paper pigments, and wirebar have earlier faced the necessity to be ISO 9000 registered or be out of business.

So today the growing trend is for many industrial-mineral companies to gain ISO registration, and a growing awareness in the metals mining industry that future export and some value-added product sales will hinge on attaining ISO 9000 registration.

#### **What do operators include in ISO 9000 registration?**

Many ISO 9000-certified industrial mineral producers leave their mines, mine development programs, and exploration activities out of the ISO 9000 registration process. Certainly, quality-management systems as a whole are much more logically suited to processing operations, where people, processes, and machines follow more consistent flow-sheets and patterns. In these cases, the mine is treated as an outside supplier. The quality of its product, such as plant feed and concentrates, and its overall operations are still subject to the company's auditing, both to their QMS standards, and to ISO supplier-auditing standards.

The introduction of statistical QC programs over the past four decades has presented a challenge to the mining industry, which historically relied more on prized mining traditions and rigid past practices. While the traditional metal mining industry has shown general reluctance to adopt new approaches (preferring to use bigger and bigger machines), the industrial mineral sector has more aggressively pursued newer quality management system programs and practices as their customers and markets have demanded.

#### **Why include the mining sector?**

The heart of any industrial mineral operation is its mineral deposit, or raw material supply. Without it there is nothing, although in the industrial mineral world a lot more attention is generally paid to processing than mineral extraction.

Quality control can be achieved in two ways in an industrial mineral venture: (1) careful definition of the reserves, following an intelligent mining plan, and selective mining, and (2) efficient process control management.

Because most operations concentrate on the processing sector, less attention goes into control of the raw materials. More and more reliance is placed on expensive capital equipment and expanded processing, and raw material control becomes more of a blending exercise to achieve more constant headfeed quality. Sometimes this is the most cost-effective way to go, so it can be a valid way to attack mineral extraction. But many other times, the versatility possible by more selective mining is lost, and cost savings made in the mines or quarries are lost many times over by higher rejection rates of intermediate and final products farther up the processing or manufacturing chain.

An intelligent working-reserve definition and good mining control can greatly enhance the profitability and effectiveness of an operation, and here is where the incorporation of a sound QMS (e.g. ISO 9000-based) can significantly improve the QA factor of an operation.

#### **Where do geology and reserves management fit in?**

An effective industrial mineral facility must have a grasp of three raw material elements: (1) the geology of the deposit, (2) formal reserves and working reserves, and (3) mine planning to supply optimal headfeed(s) to a processing plant.

A large corporation will have such material in well-organized, computerized form, prepared and shared by a number of employees. One or two managers, at a small producer, will likely handle such material manually—even on yellow paper pads or in someone's head. It is best, however, to have such material in a form that others can share, interpret, and criticize.

#### **How can you assess the effectiveness and quality of your own raw material programs?**

An industrial mineral producer can assess the effectiveness and quality of its own raw materials programs and working reserves by two different approaches: (1) Set up the most qualified technical workers and managers as an internal overview committee and conduct extensive audit and assessment of the operation's practices, problems, QC, and tonnage/quality track record. (2) Hire highly-qualified, outside consultants to audit the operation intensely, assessing the operation's practices, problems, QC success, and tonnage quality record from an impartial standpoint.

Internal auditing has three advantages: (1) All the people involved are highly knowledgeable about the subject operation. (2) It costs less. (3) Confidentiality is not threatened.

Weaknesses of internal auditing are threefold: (1) Committee members may or may not be impartial, and are unlikely to criticize themselves, their departments, or higher management. (2) Upper management is likely to have hidden agendas/goals that they persuade the committee to reach. (3) The committee members are less likely to know how and how well competing operations do things, and therefore how their own company stacks up against the competition.

External consultants can offer: impartiality; broader range of knowledge; better knowledge of competitor practices, strengths, and weaknesses; and can focus on goals free of internal agendas at all levels, if you chose the right consultants. Obviously, they must be highly qualified and experienced with the commodity and process and should show an excellent past record of past operational auditing and interfacing with overall QA/QC situations. Their results are likely to be closer to reality, but they indeed cost more.

#### **Does industrial mineral exploration fit in ISO 9000?**

Clearly, the answer is yes and no (tongue in cheek). Certainly, the routine administrative exploration functions, such as controlling information flow, handling and testing samples, setting up drilling/sampling programs, documentation and presentation of data and results, laying out exploration programs, and periodic progress reporting can be tracked and related to a quality management program. It would improve the overall efficiency of any corporate exploration group to have such quality management control, but few industrial mineral companies would fund such a program, and would consider it overkill within ISO 9000 registration. Exploration in most industrial mineral companies is commonly their most under-funded and poorly supported sector.

By its very nature, mineral exploration is a function of imagination, innovation, and bold new thought, none of which thrive in a rigid system of control. Success in an industrial mineral program may follow several years of failures and dropped properties before finding one or more very good new sources. By commonly accepted quality standards, the exploration business is a failure-laden enterprise. So this element may justify leaving exploration out of ISO 9000 registration or shielding it so that unreasonable quality standards do not stifle it.

### The quality standards of ISO 9000

ISO 9000 consists of a series of basic standards or ISO numbers: The first standard, itself termed "ISO 9000," defines the basic framework of the program and explains its basic definitions and concepts (Table 1). It also guides companies in selecting and using the standards in the series. "ISO 9001," "ISO 9002," and "ISO 9003" are the actual quality system core models that a supplier must implement to become registered to the international standard. These core models are explained below. "ISO 9004" is a quality system model also, but facilities do not register to it. ISO 9004 is more of a system of guidelines for facilities that want to implement an ISO 9000 quality system for its inherent benefits, but do not want to be under the contractual obligation and enforced conditions that are associated with registration. Variety "ISO 9004-1" relates to products and "ISO 9004-2" to services.

When a company become registered to ISO 9000, it must adhere to an established list of quality-system requirements. These conditions or standards are generic by nature, so they can be applied to any service or product made anywhere in the world. They assure that the out

put of a facility's process meets the quality requirements of the customer.

A company must adopt one of three core quality-system models ISO 9001, 9002 or 9003 to become certified to the ISO 9000 quality standard. Each company selects the contractual model that most closely fits the scope of its operations.

Descriptions of the three basic standards comprising a contractual core model are:

- (1) ISO 9001 is the most comprehensive core model, and assures quality over the full range of design, development, production, installation, and servicing. It generally applies to manufacturing companies that design and build their own products. ISO 9001 is comprised of 20 quality system requirements.
- (2) ISO 9002 generally applies to facilities engaged in production and installation only, and whose products are designed and serviced by subcontractors. Companies that adopt this standard must adhere to 19 of the 20 quality system components that appear in ISO 9001, excluding only the design control element.
- (3) ISO 9003 has the most limited scope and requires conformance only to final inspection and test procedures. It is most often used by testing laboratories and equipment distributors. ISO 9003 has 16 of the 20 quality system requirements that comprise the ISO 9001 standard, and some of these are applied less rigorously than for the ISO 9001 core model.

Companies become registered to ISO 9000 after they have implemented one of the three contractual core models (ISO 9001, 9002, or 9003) and proven, through documentation and performance, that they meet all of the technical quality-system requirements. ISO registration is usually awarded on a per-facility basis, rather than a per-company basis. If a manufacturing company has eight facilities, all eight would normally need to seek registration individually. Multiple-site registration under a single certificate may be allowed in limited circumstances where the site operations are virtual extensions of the headquarter facility doing the same job under the same system and control.

Once certified, a facility undergoes semi-annual auditing to ensure that it is adhering to its certifying controls or standards and practices. Intense auditing is done of operational performance, day-to-day plant management, and the voluminous documentation required. Areas where the operation fails must be corrected, and the entire operating system brought up to standard to assure continued certification.

Auditor approval means a facility is doing a good / satisfactory job of maintaining its quality standards and practices, will retain ISO certification, and deserves a pat on the back. And yes, a company can flunk ISO approval and be de-certified.

### Auditing of suppliers to ISO 9000 registered facilities

ISO 9000 quality standards require that a registered facility must audit its suppliers whether they supply products or services if these will impact the quality of the facility's final products. This puts pressure on suppliers to up-grade their own Quality Management Systems (if they have any) or to become ISO 9000 registered themselves.

TABLE 1—ISO9000 quality system components reference.

ISO9000	ISO9001	ISO9002	ISO9003*
4.1 Management responsibility	X	X	X
4.2 Quality system	X	X	X
4.3 Contract review	X	X	X
4.4 Design control	X		
4.5 Document and data control	X	X	X
4.6 Purchasing	X	X	
4.7 Control of customer-supplied product	X	X	X
4.8 Product identification and traceability	X	X	X
4.9 Process control	X	X	
4.10 Inspection and testing	X	X	X
4.11 Control of inspection, measuring, and test equipment	X	X	X
4.12 Inspection and test status	X	X	X
4.13 Control of nonconforming product	X	X	X
4.14 Corrective and preventive action	X	X	X
4.15 Handling, storage, packaging, preservation, and delivery	X	X	X
4.16 Control of quality records	X	X	X
4.17 Internal quality audits	X	X	X
4.18 Training	X	X	X
4.19 Servicing	X	X	
4.20 Statistical techniques	X	X	X

\*Some of the individual requirements in the ISO 9003 model are less comprehensive than ISO 9001 and ISO 9002.

**QS9000—Certification of suppliers to ISO 9000 Registered automobile/truck manufacturers—An American addition**

QS9000 is a new QC model that was developed by Chrysler, Ford, and General Motors. Table 2 shows the QC9000 sector-specific standards that apply to all suppliers, internal and external, who provide production and service parts and materials to the "Big 3" automakers.

QS9000 is a unification of General Motors' "North American Operations Targets for Excellence," Ford's "Q-101 Quality System Standard," and Chrysler's "Supplier Quality Assurance Manual." This new quality system model centers on ISO 9000, the international quality standard. In fact the QS 9000 document incorporates ISO 9001 quality-system core models in its entirety.

QS 9000 was created by the Big 3's Supplier Quality Task Force, with additional input from the following truck manufacturers: Freightliner, Mack Trucks, Navistar International, PACCAR, and Volvo GM Heavy Truck. QS 9000 makes it easier for suppliers to do business with the Big 3 by standardizing their business practices. Suppliers to the Big 3 no longer have to satisfy individual customer requests as the automakers share the same supply data base.

**The future—ISO 14000!**

The ISO world is still growing! And what's next—ISO 14000! ISO 14000 will be worldwide in scope and equivalent to the European "Eco Management and Audit" (Eco Audit), a management auditing system currently in effect within the European Community (EU). The new standards will address environmental issues that go beyond operations to include products and services and could impact internal management practices. ISO 14000 is being designed to achieve several purposes: (1) to make it more difficult for individual countries to use environmental issues as trade barriers, (2) to create a universal set of standards to help businesses meet their commitment to the environment, and (3) to allow companies to avoid multiple registrations, inspections, and certifications as their products cross from country to country.

To achieve these goals, ISO 14000 standards will address five major areas: (1) general corporate policies and procedures governing environmental management systems, (2) auditing, (3) performance evaluation, (4) environmental labelling, and (5) life-cycle assessment.

**What are the advantages of ISO 9000?**

The ISO 9000 standards offer a company several advantages:

- (1) They will guide management to build quality into their products or service, and help to avoid costly inspections, warranty costs, and rework.

TABLE 2—QS 9000 sector-specific requirements.

1.1	General
1.2	Quality system
2.1	Contract review
2.2	Design control
2.3	Document and data control
3.1	Purchasing
3.2	Control of customer-supplied product
3.3	Product identification and traceability
3.4	Process control

- (2) Laborers achieve a higher level of training and understanding of their operations, and labor relations are commonly improved.
- (3) These international standards are sanctioned by most countries of the European Community making ISO 9000 certification a virtual prerequisite for doing business there.
- (4) The program encourages closer producer and supplier relationships.
- (5) European businesses place great importance on ISO 9000 certification because it is a valuable guide in insuring the quality of a facility's product or service. For this reason, registration to the international standard is becoming increasingly desired, expected, and even required by certain markets and industries.
- (6) Internal auditing invariably raises employees' knowledge of the operation and leads to corrections of previously unrecognized problems and to improvements in procedures.
- (7) Deficiencies in testing standards and calibration in laboratories and process control are commonly discovered.
- (8) ISO standards closely define each employee's authority and responsibilities as related to quality. This empowerment generally leads to increased employee involvement, pride, and feelings of overall responsibility.
- (10) ISO 9000 helps to achieve consistent levels of quality.

Lloyd's Register Quality Assurance Ltd. conducted an independent study of benefits perceived by companies that had reached ISO 9000 with the following results: (1) 86% of managers stated that their program's peak achievement was better management control. (2) 76% said that a Quality Management System had enabled them to deliver better service to their customers and to achieve greater consistency in systems company-wide. (3) 69% reported productivity gains and increased efficiency. (4) 69% felt that they had improved their competitive position. (5) 67% achieved better internal quality systems. (6) 63% felt that they have improved their advertising and marketing positions. (7) 49% believed that they had gained market share. (8) 42% had to undergo fewer customer audits. (9) 31% recognized significant gain in international markets.

**What are the disadvantages of ISO 9000?**

- (1) It takes an enormous amount of involvement and personal commitment to reach the certification level, and this may detract from other corporate needs or programs.
- (2) The amount of paperwork can lead to frustration as well as adding to management costs and demands.
- (3) Being an ISO 9000 certified company does not mean that one's product is better, only that their performance in making and distributing that product meets certain high-quality standards. Another company with better products and/or lower costs/ prices might still out-perform you without being certified.
- (4) The cost of achieving registration, which is generally in a range of \$50,000 to \$250,000, is significant. Some companies do not use outside consultants, and keep their internal costs under this program to a minimum, a few achieving certification for less

than \$50,000. Some other companies have deliberately put in a great deal more effort than required—up into a range as high as \$1 million.

- (5) Certification involves an element of control by external parties in the private finances and business of a corporation. This loss of privacy may benefit competitors downstream.
- (6) When everyone is registered under ISO 9000, what does one gain? For then an individual registered operation loses the element of exclusive advantage in being one of the few who *are* registered in a given field.
- (7) The process does not deal directly with product quality or customer satisfaction.
- (8) There are no firm requirements for technical competence by the registrars relative to the industries being audited.
- (9) Auditors do not assess whether a system is practical and makes technical sense, but rather whether a company system is operating as defined in its quality system.

### Is ISO 9000 for everyone?

No, ISO 9000 is not for everyone. This should be considered before entering the ISO 9000 registration track. ISO 9000 registration works best for operations or organizations engaged in international trade and/or a strongly competitive domestic market. It is a "must" to be one of the players in some major marketing scenes. Mineral producers selling into very local markets or to markets with light competition, very loose specifications, or heavily advertising-oriented consumer factors may not gain any benefit from ISO 9000 registration and can handle their programs as well and for less cost through TQM or other quality approaches. Most companies that have gone through all the initial documentation and preparation—or "jumped through all the hoops"—feel that the improved quality awareness and control, and their resulting better grasp of how their company or facility runs, were worth it for that alone.

### How do you get ISO-certified?

There are essentially three phases in pursuing ISO 9000 registration: (1) implementation of an ISO 9000 Quality Management System that conforms to a chosen core model standard, (2) documenting this system thoroughly with an operations manual, and (3) three-to-six months successful operation within this system.

Typically, each company has an "ISO 9000 Management Committee" devoted first to the push for registration, then later to on-going maintenance of ISO 9000 programs and auditing contacts. A "Management Representative" is generally assigned within the company to direct the progress of registration and to interface with all groups on achieving and maintaining ISO 9000 registration. The Management Representative is a member and possibly the leader of the Management Committee. Two teams are also developed within the company structure: a "Quality Council," composed of management, QC, and union and other representatives who set the objectives and make final approval of all studies and manuals, and (2) a "Quality Line Team," of line managers, lead workers, and foremen who work on day-to-day problems and studies.

The "Quality Council" develops "The Implementation Plan," which directs the following functions: (1) correct-ing non-conformities and problems, (2) conducting gen-

eral training programs on the ISO 9000 process internally (3) conducting most formal presentations, (4) directing internal auditing, (5) directing the training function, (6) directing all documentation, and (7) writing the Quality Manual. The Quality Manual is the blueprint for the Quality Management System.

Work that affects quality must always be planned, controlled, and documented by the appropriate Line Functionary employees. Typically, it takes about \$50,000-250,000 and 6-18 months to implement an ISO 9000 program and achieve registration.

Three basic rules to follow in all ISO 9000 work are: (1) Do what you say. (2) Say what you do. (3) Be able to prove it.

### Six steps in achieving certification

Functionally, there are a number of steps in achieving ISO 9000 registration. These may not all run smoothly, and the registration process allows the adjustment and revision that may be necessary over the course of certification. The steps are:

- (1) **Initiate the application process with a registrar.** Choose a registrar group that fits your needs and style and has the expertise to cover your business activity or "scope." Pick an accredited firm from the approximately 40 such groups in the United States. Get registration/certification through an EU-accredited registrar if possible.
- (2) **File application. Apply with** the assistance of the consulting registrar.
- (3) **Undergo assessment of documentation.** Most companies employ a separate ISO 9000 accredited consultant (who is not a registrar) to assist them with internal audits, documentation, etc.
- (4) **Undergo on-site audit/assessment. This** will be done by the ISO 9000 sanctioned auditing team.
- (5) **Carry out corrective actions.** These actions are subject to re-checking by the ISO auditing team.
- (6) **Pay fees.**

The bulk of internal study and documentation are carried out within the first and third steps listed above. Also, a company typically conducts internal auditing before the formal ISO 9000 audit to find and correct its own problems before airing these to the outside auditing teams.

Upon successful certification, the newly-registered company receives a formal certificate from the governing ISO 9000 body, with a serial number assigned only to that company, and rights to use the ISO 9000 logo, its serial number, and certain statements in its advertising and in contacts with customers and the public.

### What happens after certification?

The performance and documentation of the implemented ISO 9000 program continue during subsequent operation of the registered facility. Semi-annual audits are conducted by ISO 9000 accredited registrars to ensure that the registered operation is in compliance with ISO and its own quality standards. And, of course, annual fees must be paid to the registering body.

ISO 9000 is more than an exercise of official duties and responsibilities. It is also on-going attitude and personal commitment of management and workers to keep the quality of performance and output up to superior levels.

Some mining companies that have expressed success under ISO 9000 are Dry Branch Kaolin Company; Engelhard Corporation; J. M. Huber Corporation; Inspi-

ration Copper Company; Luzenac Talc American Inc.; PPG Industries; Owens Corning Fiberglass; and United Clays Inc.

#### **Acknowledgements**

I wish to thank Behre Dolbear & Company Inc. for their support of my ISO 9000 investigation and research; Frank Alsobrook, convener of the 1994 SME conference on ISO

9000 in the Mineral Industry in Nashville, Tennessee, for use of his extensive notes and files on ISO 9000; and to the consulting firms of Perry Johnson Inc. and Butler Quality Systems, who have given me much assistance and source materials on the ISO 9000 system and its registration procedures. I am particularly grateful to Felicula Holmes and Beth Foster for their clerical support and graphic work presentations, respectively.



# Spreading the word about geology through teacher workshops

Claudette M. Simard

*West Virginia Geological and Economic Survey, P.O. Box 879, Morgantown, West Virginia, 26507-0879 USA*

**Abstract**—As society moves into the next century, educators are beginning to realize the importance of improving science literacy among citizens. Rather than separating science into traditional categories, such as chemistry and physics, the national trend is to stress a thematic approach that demonstrates the interrelationship of all sciences to our daily lives. What better vehicle to use than earth science—one that includes all other sciences.

At the West Virginia Geological and Economic Survey, we decided to help by educating citizens in West Virginia, a state where mineral resources are the backbone of our economy. With a three-year, \$570,000 National Science Foundation grant, a \$100,000 contribution by West Virginia Department of Education, and cooperation from West Virginia University, the Survey conducted a series of teacher institutes called "Earth Science in West Virginia for the Twenty-first Century." Seven two-week summer institutes were held at the Survey from 1992 to 1994. A total of 147 kindergarten to 12th grade teachers were instructed by a group of Survey geologists, educators, and other scientists.

The institute sessions included geology topics ranging from general to specific, a survey of earth-science topics, laboratory exercises and activities, field trips, and activities designed to enhance the participants' earth-science background and encourage professional growth. A resource kit of classroom activities, books, maps, topic overviews, and discussion ideas for classroom use were developed and presented to the teachers. Emphasis was placed on enabling teachers to clearly demonstrate to their students how earth science impacts their everyday lives. This emphasis was based on our belief that earth-science topics and activities relevant to a student's home area provide an increased level of scientific curiosity, motivation, and retained knowledge. To reach an even wider audience, 27 graduates of the two-week sessions returned for one-week workshops where they planned their own one-day workshop and field trip for colleagues in their local area.

From these workshops, we have successfully spread the word about earth science and geology, important sciences that can be taught at any level, inside or outside the classroom. The Survey has also gained welcomed publicity and an enhanced reputation with the state's citizenry through teachers and school children. We continue disseminating information by presenting workshops and talks at national and state professional educators meetings and by visiting classrooms.

## Importancia de la geología. Comunicando el mensaje por medio de talleres de trabajo para maestros

**Resumen**—Al entrar la sociedad en el siglo veintiuno, los educadores se van dando cuenta que es importante estimular el interés del ciudadano en las ciencias naturales. En vez de dividir la ciencia en sus categorías tradicionales, como ser química y física, la tendencia nacional es la de poner énfasis sobre temas que demuestran las relaciones mutuas de todas las ciencias en la vida diaria. No hay mejor vehículo para realizar este propósito que la geología que comprende a todas las demás ciencias.

En el Servicio Geológico y Económico del Estado de Virginia Oeste (*West Virginia Geological and Economic Survey*) hemos decidido colaborar en la educación de los ciudadanos puesto que los recursos minerales constituyen la base de la economía. Con una subvención por un total de \$US 570,000, otorgada por Fundación Nacional de Ciencias de los E.U.A. (*U.S. National Science Foundation*), válido por tres años, otra contribución de \$US 100,000 del Departamento de Educación del estado de Virginia Oeste y la cooperación de la Universidad de Virginia Oeste, el Servicio Geológico y Económico condujo una serie de institutos para maestros bajo el título de "Ciencias Terrestres para el Siglo Veintiuno en Virginia Oeste." De 1992 a 1994 se condujeron siete institutos de verano, de dos semanas cada uno, en la sede del Servicio Geológico. Participaron un total de 147 maestros desde jardín de infantes a grado 12. Un grupo de geólogos del Servicio Geológico, educadores y otros científicos sirvieron de instructores.

Las sesiones trataban desde temas geológicos generales hasta específicos, un resumen de problemas de ciencias terrestres, ejercicios y prácticas de laboratorio, excursiones de campo y actividades preparadas con el propósito de enriquecer en los participantes el conocimiento de las ciencias terrestres y estimular el crecimiento profesional. Se preparó y distribuyó a los maestros participantes un juego de materiales, libros, mapas, resúmenes de temas, ideas para discusión. El propósito era capacitar a los maestros para que puedan mostrar a sus alumnos con claridad cómo las ciencias terrestres afectan la vida diaria porque creemos que los temas

geológicos y actividades pertinentes al lugar donde viven los estudiantes estimulan su curiosidad científica, motivación y retención del conocimiento adquirido. Para alcanzar una audiencia aun más amplia, 27 graduados de las sesiones de dos semanas volvieron para unos talleres de trabajo de una semana cada uno donde ellos proyectaron sus propios talleres de trabajo de un día y excursión de campo para colegas en sus respectivas localidades.

Por medio de estos talleres de trabajo hemos proclamado con éxito el mensaje de la importancia de las ciencias de la tierra y la geología, disciplinas importantes que se pueden enseñar en todos los niveles de la escuela y fuera de ella. El Servicio Geológico también ha ganado en reconocimiento y reputación con los ciudadanos del estado a través de los maestros y los escolares. Continuamos disseminando información por medio de talleres de trabajo y presentaciones en reuniones profesionales de educadores tanto a nivel nacional como estatal y mediante visitas a escuelas.

### Introduction

Never has science education been more important to the general population. In particular, rudimentary understanding of earth science is very important for making wise decisions for mineral use, value and reclamation, waste disposal, and maintaining potable water. If children receive the fundamental building blocks at all grade levels, by the time they are adults they will have enough background knowledge to make informed decisions on issues such as the value of mineral resources, the effects of mining on society, and reducing the risk of geologic hazards.

In order to increase science literacy in West Virginia, the Department of Education has recently developed a new curriculum framework that requires the integration of earth science in kindergarten to 12th grade. In this new framework, the Department of Education promotes science comprehension through increased hands-on and activity-based thematic instruction rather than passive rote learning. To offer teachers the opportunity to enhance their earth-science background, the West Virginia Geological and Economic Survey held National Science Foundation-funded institutes (Grant No. ESI-9155264) formally called "Earth Science in West Virginia for the Twenty-first Century."

### Funding

In 1992, the West Virginia Geological and Economic Survey applied for and received a three-year, \$570,000 National Science Foundation grant to conduct "Earth Science in West Virginia for the Twenty-first Century" teacher institutes. A teacher later dubbed it as "RockCamp," a name we immediately adopted. The Survey worked in conjunction with the West Virginia Department of Education, which contributed \$100,000 of Dwight Eisenhower Mathematics and Science Education funds for teacher stipends, and West Virginia University, which provided graduate credit and an expert field geologist.

West Virginia University dormitories were used for housing and meals. Two rented vans were used for the 20 minute daily commute from the dormitories to the Survey's headquarters, and also for local field trips.

Seven two-week summer institutes were held on our premises from 1992 to 1994. Each workshop served 21 teachers, for a total of 147, who taught at all grade levels. The institutes were led by a group of Survey geologists, staff members, and educators covering an array of fields including industrial minerals, coal, hydrology, field geology, petroleum geology, geographic information, and computer applications. To round out the earth-science program, two National Science Foundation Presidential Awardees for Excellence in Science Teaching covered astronomy, weather, topographic maps, and environmen-

tal issues, and shared their ideas for classroom management and teaching strategies with institute participants.

The institutes not only focused on earth-science topics but also included discussions by representatives of the West Virginia Department of Education on the latest teaching methods integrating all aspects of science and active learning with hands-on activities. Our aim was to promote these new teaching methods in our institute approach.

Over the three years, each of the seven two-week institutes followed the same format. The first week started with a welcoming barbecue on Sunday, at which time a RockCamp graduate talked about his or her institute experience. Then, the teachers watched a video tape, *Rocks and Rivers: West Virginia's Geologic Heritage* (Simard and Repine, 1993), as an introduction to the relationship between geology and the state's history, culture, and economics. This video tape was produced by Survey staff as part of the RockCamp project. At the end of the evening, the teachers left with the first armload of books, handouts, the video tape, and classroom ideas and materials they would receive throughout the institute. From Monday through mid-Wednesday, the teachers were given general introductory background information in preparation for the three-and-half-day field trip in the latter part of the week. Topics ranged from industrial minerals to volcanoes to interpreting geologic environments.

All RockCamp presentations conformed to the activity-based instructional models outlined in the West Virginia Department of Education science curriculum framework. For example, the industrial-mineral activity, "Stone Age for the Modern World," began with an explanation of the importance of industrial minerals and then focused more specifically on which industrial minerals were produced in West Virginia, their uses, and where they were located on our *Mineral Resources of West Virginia* map (King and Kirstein, 1987). The activity was thus based on the map. The teachers worked in pairs to determine where on the map most economically to build a coal-fired power plant. The plant was to have a limestone pollutant control device and to use only locally available minerals. Parameters included proximity to water, start-up natural gas, coal fuel, crushed stone for haul roads and concrete, cement, brick and glass for the office building, and flagstone walks.

A three-and-half-day field trip on a chartered bus used all of the background information the teachers had learned up to that point. It also introduced them to much more. While crossing each of West Virginia's physiographic provinces, they learned firsthand about the geology of West Virginia, its fuel and industrial-mineral resources, geologic hazards; environmental problems,

and how all of these tied into the economy, culture, and history of the state. To emphasize the economic aspect, field-trip stops included a tour of a limestone quarry, cement plant, and a surface coal mine having award-winning reclamation work.

Besides the learning experiences, this trip provided each participant with the opportunity to collect classroom rock and fossil specimens and to take photographs. They also gained first-hand experience in using topographic maps. The field trip ended with a content evaluation and review exercise to help them reinforce their knowledge.

The second week included additional activities, demonstrations, and local field trips to reinforce and expand on what was learned the first week. Trips were taken to local coal mines to experience various mining techniques and the associated geologic hazards. Hands-on activities in astronomy, hydrology, geographic information, computer use with oil and gas data, and environmental issues were also covered. Interspersed throughout the second week, RockCamp graduates from previous sessions demonstrated or led classroom-proven activities they developed as a result of their RockCamp experience. One entire day was devoted to the teachers demonstrating an activity idea they created during the institute. These activities were later collected in book form and distributed to each participant. Throughout the two-week session, the teachers kept an implementation notebook for recording their ideas on how to incorporate the day's activities in their own classroom. These were shared with other participants at the end of each day and often led to additional classroom ideas.

### Success of RockCamp

The goal of RockCamp, to enhance the teachers' earth-science background and feel more comfortable teaching earth science with a hands-on approach, was achieved. According to post-institute surveys conducted by an independent evaluator, the teachers felt more confident and willing to teach earth science (Hambrick, 1994). All of the teachers felt there was a positive change in students' understanding and knowledge of earth science resulting from the implementation of RockCamp ideas. Thus far, the 100 participants of the 1992 and 1993 sessions have shared what they have learned with approximately 13,000 students and 1,400 other teachers (King, 1993). Many of the RockCamp graduates still refer to their implementation notebook when preparing lessons (Repine, 1994).

The increased comfort level in teaching earth science is very important because the new coordinated and thematic science-curriculum framework developed by the West Virginia Department of Education requires incorporating earth science in science lessons at all grade levels. Not only are the teachers sharing the information at their own schools, they have been assuming leadership roles by sharing what they have learned with others through school, county, and regional in-service workshops; faculty-senate presentations; local, regional, and state teachers conferences; and as field-trip leaders. Participant teachers have also become known as resource contacts for West Virginia fossil and rock specimens, books, posters, maps, slides, and the videotape distributed at the workshop.

Careful planning and diligent use of available funds and resources have resulted in the Survey's gaining approval from the National Science Foundation to host another

RockCamp in the summer of 1995. As a result of our excellent reputation, the Survey's state budget was increased by \$60,000 to hold a state sponsored RockCamp in 1996. The West Virginia Coal Mining Association will also be a sponsor.

### RockCamp II

To disseminate further RockCamp ideas and to enhance teachers' leadership skills, we offered two one-week RockCamp II sessions in the third year (1994) of the National Science Foundation grant. Twenty-seven RockCamp graduates became "Outreach and Resource Specialists" after finishing RockCamp II. Singly or in twos or threes, they were to conduct a six-hour workshop and lead a field trip for colleagues in their local or regional school district.

Each RockCamp II session provided teachers one-on-one assistance in learning about the geology of their local area and organizing, planning, and leading field trips. These skills were enhanced through actual practice trips to local sites. The teachers who have already held their workshops and field trips have reported great success. They demonstrated to their colleagues that hands-on earth science can easily be incorporated in or out of the classroom. These enthusiastic teachers have become known as contacts for earth-science activities, materials, and resources in their school districts and counties.

### Survey changes

As a result of RockCamp, the Survey's emphasis now includes educational outreach. Working closely with the teacher participants has helped define how best to serve the general public's need for geologic information. As an outgrowth of this, several of the teachers are cooperating with the Survey to improve our non-technical publications. Also, compilations, in book form, of teacher and staff RockCamp activities are available to any teacher for nominal cost.

The Survey's need for a full-time staff education position was apparent and has been created. This person runs the RockCamp institutes; serves as a contact for teachers; makes presentations at local, regional, and national educational meetings; visits classrooms; and acts as a liaison for other state surveys interested in sharing information about earth-science institutes.

The Survey's videotape, *Rocks and Rivers: West Virginia's Geologic Heritage*, has been a very successful vehicle for reaching the general public as well as teachers and school children. Creating the videotape has led to the Survey staff's involvement as guest hosts on a West Virginia Public Television broadcast about the local area's geology. Plans are in the making for a six-part series on the geology of West Virginia that will hopefully be broadcast regionally, and perhaps nationally. The videotape has also been given to state-park naturalists to show their visitors and is an "eye-catcher" for Survey exhibit booths at the State Capitol, sportsman' shows, and other public exhibits.

### Welcomed publicity

By successfully holding RockCamp and RockCamp II institutes for three years, the West Virginia Geological and Economic Survey has become much more widely known throughout the state. Although we have had educational publications and have served the public since our inception, most West Virginians have never heard of our agency. By providing these institutes and armloads of materials to the participant teachers, and by visiting

their classrooms, the word has spread that the Survey is a great resource for earth-science information.

#### **Acknowledgments**

I thank Carl Smith, Tom Repine, and Mitch Blake for their thoughtful comments and insights that improved this manuscript.

#### **References**

Hambrick, K. 1994, Earth Science in West Virginia for the Twenty-first Century—Evaluation of the impact of the two 1992 and three 1993 summer earth science institutes: Appalachia Educational Laboratory Inc., Charleston, West Virginia, 60 pp.

King, H. M., 1993, First progress report, Earth Science in West Virginia for the Twenty-first Century (Grant no. ESI-9155264): National Science Foundation, Arlington, Virginia, 11 pp.

King, H. M., and Kirstein, D. S., 1987, Mineral resources of West Virginia: West Virginia Geological and Economic Survey, Map-WV24, scale 1:500,000.

Repine, T. E., Jr., 1994, Second annual progress report, Earth Science in West Virginia for the Twenty-first Century (Grant no. ESI-9155264): National Science Foundation, Arlington, Virginia, 10 pp.

Simard, C. M., and Repine, T., 1993, Rocks and rivers: West Virginia's geologic heritage (videotape): I. C. White Memorial Symposia Fund Limited.

## APPENDIX 1

Presentations as abstract only with Spanish translations

# Geology and industrial minerals of northeastern Mexico

Armando E. Alatorre<sup>1</sup>, Arturo Colin<sup>1</sup>, and Ken Santini<sup>2</sup>

<sup>1</sup>*Fideicomiso de Fomento Minero, 2500 Saltillo, Coahuila, Mexico;*

<sup>2</sup>*Santini and Associates, 1396 South Ward Way, Lakewood, Colorado 80228, USA*

The northeastern region of Mexico, which includes the States of Coahuila, Nuevo Leon, and Tamaulipas, is located south of Texas (Fig. 1). It is Mexico's largest industrial-mineral-producing region. The area consists mainly of marine sedimentary rocks and lies in three geological provinces (1) the Mesozoic Mexican Folds and Faults Belt province; (2) the Cenozoic Gulf of Mexico Geoclinal province, and (3) the Mesozoic Coahuila Platform province (Fig. 2).

The Mexican Folds and Faults Belt province is made up of Permian carbonate rocks, Triassic continental red beds, Jurassic evaporites, and Cretaceous carbonate rocks. This entire sequence, greater than 3,500 m in thickness, was subjected to folding, thrust-faulting, and block faulting during the Laramide Orogeny, giving rise to typical basin-and-range topography. Scattered Tertiary clastic sediments and volcanic rocks are also present. Industrial-mineral deposits that occur in the province include (1) Jurassic gypsum and phosphate, (2) Cretaceous limestone and dolomite, and (3) Tertiary barite and sodium sulfate/sodium chloride (Fig. 2).

In contrast, the Gulf of Mexico Geoclinal province consists mostly of Cretaceous to Holocene sedimentary rocks. These rocks have been moderately to highly folded and faulted. Sedimentation ranges from calcareous to siliciclastic. The major industrial minerals present are (1) Jurassic salt/gypsum, (2) Cretaceous limestone and dolomite, and (3) Eocene silica sand. Tertiary alkaline intrusive rocks containing nepheline syenite are also present.

The Coahuila Platform province is comprised predominantly of Permian to Holocene sedimentary rocks. In general terms, the stratigraphy is very similar to the Mexican Folds and Faults Belt province. The main difference is that Triassic and Jurassic sections are nearly absent. Industrial-mineral deposits include Cretaceous celestite and Tertiary fluorspar, barite, and sodium sulfate.

# Geología y minerales industriales del noreste de México

La región noreste de México se ubica al sur de Texas (Figura 1), comprende los estados de Coahuila, Nuevo León y Tamaulipas y es la mayor región productora de minerales industriales en el país. La región consiste principalmente de rocas sedimentarias y abarca tres provincias geológicas: (1) el Cinturón Mexicano de Pliegues y Fallas, de edad mesozoica, (2) el Geoclinal del Golfo de México, de edad cenozoica y (3) La Plataforma de Coahuila, de edad mesozoica (Figura 2).

El Cinturón Mexicano de Pliegues y Fallas consiste de carbonatos pérmicos, capas rojas continentales triásicas, evaporitas jurásicas y carbonatos cretácicos. Con un espesor superior a los 3,500 metros, esta pila estratigráfica sufrió plegamientos, sobrecurrimientos y fallamiento de bloques durante la Orogenia Larámica, dando lugar a una clásica topografía de Bolsones y Sierras (*Basin and Range*). Sedimentos clásticos y rocas volcánicas terciarias existen en afloramientos aislados. Los yacimientos de minerales industriales incluyen: (1) yeso y fosfato del Jurásico, (2) caliza y dolomita del Cretácico y (3) barita y sulfato de sodio/cloruro de sodio terciarios (Figura 2).

En contraste, la provincia del Geoclinal del Golfo de México en su mayor parte consiste de rocas sedimentarias del Cretácico al Holoceno. Estas rocas han sido moderada a intensamente plegadas y falladas. La sedimentación abarca desde calcárea hasta siliciclástica. Los minerales industriales más importantes son (1) sal y yeso jurásicos, (2) caliza y dolomita cretácicas y (3) arena silicica del Eoceno. También hay rocas intrusivas alcalinas del Terciario que contienen sienita nefelinica.

En la provincia de la Plataforma de Coahuila predominan rocas sedimentarias del Pérmico al Holoceno. En términos generales, la estratigrafía es muy similar a la provincia del Cinturón Mexicano de Pliegues y Fallas. La diferencia principal es que las secciones Triásico y Jurásico son muy reducidas o no existentes. Celestita cretácica, fluorita, barita y sulfato de sodio terciarios constituyen yacimientos industriales en esta provincia.



FIGURE 1—Selected cities and states of northeastern Mexico.

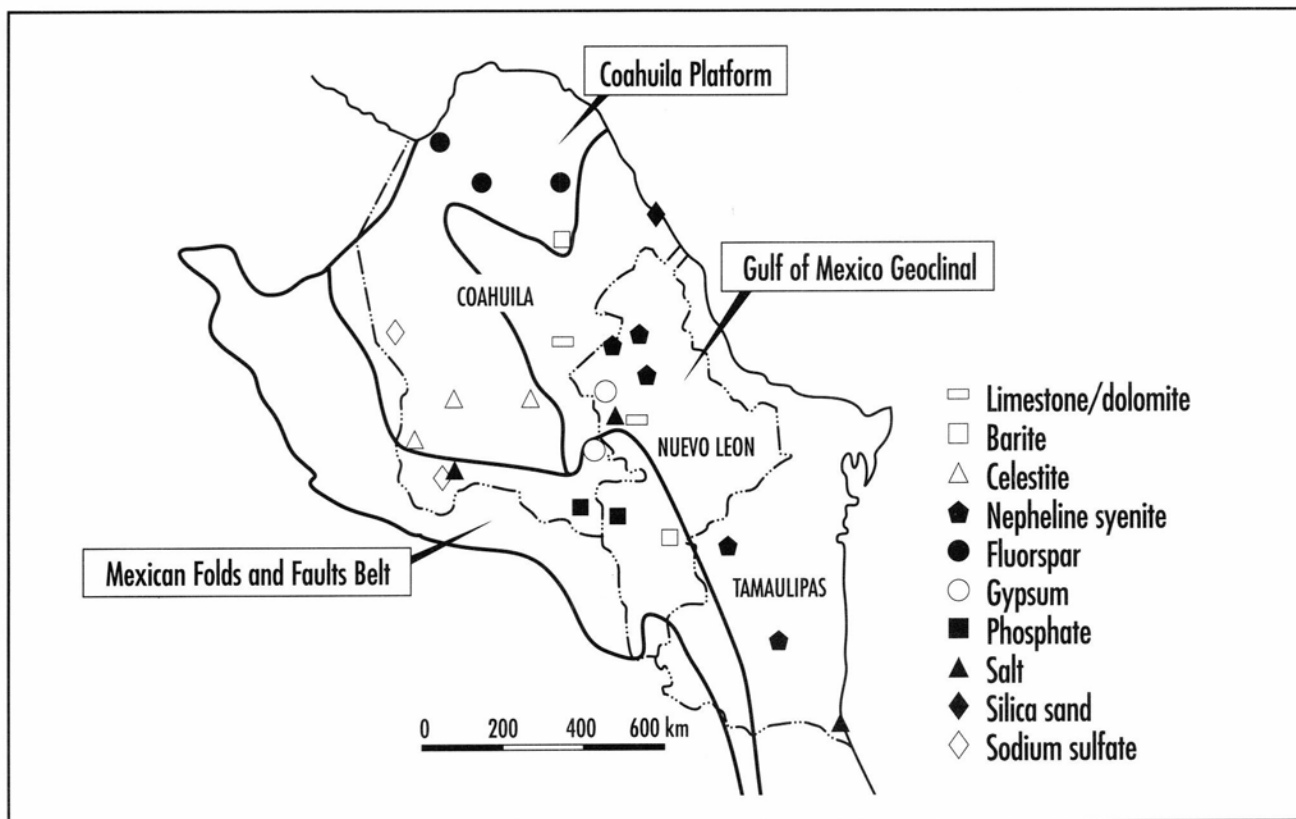

FIGURE 2—Geological provinces and industrial minerals of northeastern Mexico.

# Industrial-mineral ore analysis using laser-induced breakdown spectroscopy

J. Blacic<sup>1</sup>, D. Pettit<sup>1</sup>, D. Cremers<sup>1</sup>, W. Laughlin<sup>1</sup>, and L. Fluk<sup>e</sup>

<sup>1</sup>*Los Alamos National Laboratory, MS D462, Los Alamos, New Mexico 87545, USA;*

*ICF Kaiser Engineers Inc., Environment and Energy Group, 1900 Diamond Drive, Los Alamos, New Mexico 87544, USA*

The efficiency of mining and milling industrial-mineral ores would benefit from a rapid, real-time method of measuring ore compositions at several points along the processing stream. The current, time-consuming method of transporting samples to a centralized chemistry laboratory for detailed analysis does not lend itself to rapid adjustment of mining and processing operations. Considerable advantages would result from a remote, perhaps field-portable, method of measuring ore compositions with sufficient accuracy and speed to allow timely changes in mine or mill operations. We are investigating the feasibility of using the Laser-Induced Breakdown Spectroscopy (LIBS), method to meet this requirement.

The LIBS method is a modern variation of the old method of atomic-emission spectroscopy familiar to every analytical chemist. Transitions among states within a population of excited atoms, for example induced by high temperatures or rf fields, result in emission of light at specific wavelengths that are characteristic of the individual elements. The diagnostic flame colors of ionic solutions introduced into the high temperature zone of a Bunsen burner is the oldest and simplest application of this classic method. With LIBS, the gas flame of a Bunsen burner is replaced by an intensely focused laser beam. The extreme power density (1-10 Gw/cm<sup>2</sup>) of a short laser pulse that is focused on a solid or liquid material surface vaporizes and heats a small portion of the material, thereby producing a high temperature (~10,000-15,000 K°) plasma of excited atoms. If the light from this laser plasma or spark is collected, dispersed through a small spectrograph, and detected with modern solid-state devices, the wavelengths of the acquired spectral lines will identify the constituent elements of the surface material and the relative intensities of the lines will be proportional to the elemental composition of the surface. The advantage of the LIBS method is that small, Q-switched solid-state lasers of modest energy are available to produce short laser pulses (~10 ns), resulting in power densities sufficient to produce an analytical spark. When combined with small, low-power photodiode or CCD detector systems, digital signals representing the emission spectrum of the spark can be transmitted to a central (or portable) computer to provide a measure of elemental composition in a matter of a few seconds. When suitably calibrated and averaged over a number of sparks in a short time interval (say, 10-20 seconds), an operator would have a real-time compositional analysis of an ore continuously available.

We have performed preliminary laboratory LIBS analyses of potash-ore samples provided by New Mexico Potash Corporation and Potash Corporation of Saskatchewan, and beryllium ores provided by Brush Wellman, Inc. We observed well-defined spectral bands with good intensities for potassium, sodium, magnesium, calcium, lithium, aluminum, and beryllium. Future development of the method will involve production of calibration curves to determine accuracy and precision of the composition measurements. We also plan to investigate the feasibility of using the LIBS method to analyze ores of lithium, boron, cerium, and phosphorus.

## Analisis de minerales industriales mediante espectroscopia de descomposicion inducida por laser

La eficiencia en operaciones de mineria y purificación de minerales industriales se beneficiaria con un método rápido, en tiempo real, de analizar la composición de los minerales en diversas etapas del proceso. El lento método actual de transportar muestras a un laboratorio químico central para análisis detallado no se presta para efectuar ajustes rápidos en las operaciones. Importantes ventajas se ganarian con un método remoto, quizá portátil en el campo, de analizar la composición del mineral con suficiente precisión y rapidez como para permitir que se hagan cambios oportunos en las operaciones mineras y de preparación. Con este fin, investigamos la posibilidad de usar el método de espectroscopia de descomposición inducida por laser (*Laser-Induced Breakdown Spectroscopy (LIBS)*).

El método *LIBS* es una variante moderna del viejo método de espectroscopia por emisión atómica bien conocido por todo químico analítico. Transiciones entre estados atómicos excitados, causados por altas temperaturas o campos intensos de radiofrecuencias, producen emisiones de radiación óptica a longitudes de onda características de elementos individuados. La aplicación más antigua y más sencilla de este principio son los colores de llama producidos por soluciones iónicas introducidas en la zona de alta temperatura de un quemador Bunsen. En *LIBS* la llama del quemador Bunsen queda reemplazada con un rayo de laser intensamente colimado. La extrema densidad energética (1-10 gigavatios/cm<sup>2</sup>) de un breve pulso de rayo laser colimado en



una superficie material sólida o líquida caliente y vaporiza una minúscula porción de materia y produce un plasma de átomos excitados a temperatura altísima (10,000-15,000°K). Si se capta la luz de este plasma de laser o descarga, se la dispersa por medio de un pequeño espectrógrafo y se la detecta con modernos circuitos de estado sólido, las longitudes de onda de las líneas del espectro adquirido identifican los elementos constituyentes de la superficie material y las intensidades relativas de las líneas del espectro son proporcionales a las abundancias de los elementos que componen la superficie. Una ventaja del método es que existen lasers compactos de estado sólido con conmutadores tipo *Q* (*Q-switch*), de modesta demanda energética, que producen pulsos breves (-10 nanosegundos) adecuados para producir una descarga analítica. Si se combina un laser de este tipo con un fotodiodo de Baja potencia o sistema de detection tipo CCD, señales digitales que representan el espectro de emisión pueden ser transmitidos a una computadora central o portátil para computar y exhibir la composición elemental en pocos segundos. Con una calibración adecuada y promediando un número de descargas sobre un corto intervalo de tiempo (por ejemplo, 10-20 segundos) un operador podría obtener un continuo análisis del mineral en tiempo real.

Hemos efectuado análisis de laboratorio preliminares por el método *LIBS* de muestras de mineral de potasa suministrados por *New Mexico Potash Corp.* y *Potash Corp. of Saskatchewan*, así como de minerales de berilio proporcionados por *Brush Wellman Inc.* Observamos bandas espectrales de buenas intensidades para potasio, sodio, magnesio, calcio, litio, aluminio y berilio. En el futuro se van a producir curvas de calibración para determinar la repetibilidad y precisión de los análisis. También planeamos investigar la posibilidad de usar el método *LIBS* para analizar minerales de litio, boro, cerio y fósforo.

# Application of real-time field mapping systems to enhance data gathering and productivity in the mining industry

Gary S. Dymesich<sup>1</sup> and Barry A. Hillman<sup>2</sup>

<sup>1</sup>Condor Earth Technologies Inc., 5651 North Pershing Avenue, Suite C-3, Stockton, California 95207, USA;  
<sup>2</sup>Condor Earth Technologies Inc., P.O. Box 3905, Sonora, California 95370, USA

The continued advancements in electronic technology have allowed the mining industry to acquire greater quantities of more accurate data to utilize at all levels of decision-making. The development of geographic information systems (GIS) and related map-making technology is now being used by an increasing number of mining companies and consultants. More companies are also realizing, however, that a pretty map does not necessarily mean that it is accurate or that it correctly reflects field observations. Greater emphasis is consequently being applied to quality control and quality assurance in field mapping and ground verification in support of remote sensing.

Mapping and surveys have always been a critical component of exploration and mining. We rely on maps to determine the location of possible resources, determine their size, design and implement their extraction, and provide for eventual reclamation. Before the advent of the personal computer, total station, remote sensing, and image processing, cartography consisted primarily of hand-drawn maps. The map maker had full control of directly taking and recording measurements and ground features in the field. The plane table was the standard tool for engineers and geologists to use for field mapping and surveying projects. With the loss of the plane table, what responsible field mapping professional has not questioned the quality of field-data capture?

The recent availability of pen computers and newly developed software are allowing an electronic version of the plane table to return to the field. Electronic survey instruments such as total stations, global positioning system (GPS), and rodless laser rangefinders can be directly linked to the computer. Data can be viewed on the computer graphic display in real time as they are collected, and can be edited in the field as necessary. New maps can be created for a site, or existing digital data can be easily edited or updated as the need arises. These data can be plotted directly, manipulated and annotated in AutoCad<sup>TM</sup>, or integrated into a GIS data-base system for further analysis.

Applications of this technology in the mining industry include exploration, detailed site surveys that may characterize parameters (such as archeological, biological, geological, and environmental), mapping of the processing-plant areas, and reclamation. Integrating the laser-rangefinder survey instrument with this pen-based computer system allows a single person to rapidly perform tasks such as stockpile-volume determination and slope modeling. The safety of the operator of this system is improved over traditional surveys by not subjecting a rodperson to hazardous situations, such as standing near the top or toe of a steep mining slope for accurate data collection.

The use of real-time mapping systems can provide for efficient field-data collection, which can quickly be brought into data bases for management utilization. This timely information can be used to enhance mine productivity, and ultimately profitability.

## Aplicación de sistemas de relevamiento cartográfico en tiempo real para mejorar la colección de datos y la productividad en la industria minera

Continuos avances en la tecnología electrónica permiten a la industria minera obtener mayor cantidad de datos más exactos para utilizar en todos los niveles de hacer decisiones. Cada vez va en aumento el número de compañías mineras y consultores que usan Sistemas de Información Geográfica (*Geographic Information Systems (GIS)*) y tecnologías afines para producir mapas. Al mismo tiempo, son más también las compañías que se dan cuenta que un mapa bonito no necesariamente es correcto o refleja las observaciones de campo correctamente. En consecuencia, se da más importancia a controlar y asegurar la calidad del relevamiento y verificación en el campo de los mapas adquiridos mediante observaciones remotas (*remote sensing*).

El relevamiento cartográfico y topográfico siempre ha sido un elemento crítico en la exploración y operación minera. Dependemos de mapas para determinar la ubicación de posibles yacimientos, para estimar su tamaño y forma, para efectuar su extracción y hacer provisión para una eventual reclamación del terreno. Antes del advenimiento de la computadora personal, de las observaciones remotas y de la tecnología para la producción automática de imágenes, el relevamiento consistía principalmente de mapas trazados a mano. El operador estaba en control absoluto de las mediciones, la realización y anotación de las mismas, así como de registrar los detalles del terreno.

La plancheta era la herramienta de rigor para ingenieros y geólogos para el carteo geológico y topográfico. Con la desaparición de la plancheta cuál no es el profesional responsable para los relevamientos de campo quien no haya puesto en tela de juicio la calidad de los datos de campo obtenidos por otros métodos?

Con el desarrollo reciente de computadoras a pluma (*pen computer*) y *el software* apropiado se hace posible el renacimiento de la plancheta en una versión electrónica. Instrumentos electrónicos de triangulación, tales como estaciones totales, sistemas de orientación global (*Global Positioning Systems (GPS)*) y telémetros laser que no requieren el uso de la mira pueden ser conectados directamente a la computadora. Los datos pueden ser examinados en tiempo real, a medida que se obtienen, en la pantalla de la computadora y pueden ser corregidos o puestos al día en el campo. Se puede crear mapas nuevos para un sitio, o datos digitales ya existentes pueden ser corregidos o puestos al día. Los datos pueden ser trazados directamente, manipulados y anotados mediante *AutoCad®*, o integrados en un sistema de datos *GIS* para análisis posterior.

En la industria minera esta tecnología tiene aplicaciones en exploración, en relevamientos detallados de localidades con fines arqueológicos, biológicos, geológicos, ambientales, en el relevamiento de áreas para plantas de elaboración, para la reclamación. Integrando el telémetro laser con el sistema de computación a pluma permite que una sola persona pueda completar con rapidez tareas tales como la determinación de las reservas minerales y el diseño de taludes. La seguridad del operador es mejor que en relevamientos por métodos tradicionales porque no hay necesidad de estacionar un portador de la mira en lugares peligrosos como ser cerca de la cima o el pie de un talud empinado.

El uso de sistemas de relevamiento en tiempo real permite la colección eficiente de datos en el campo los que pueden ser incorporados rápidamente en la base de información que se requiere para pacer decisions en el manejo de la operación. Esta información puede usarse para acrecentar la productividad de la mina y, por tanto, la ventaja económica.

# The 32nd Annual Forum on the Geology of Industrial Minerals—Laramie Wyoming, May 1996

Ray E. Harris

*Industrial Minerals and Uranium Section Head, Wyoming State Geological Survey, P.O. Box 3008,  
University Station, Laramie, Wyoming 82071-3008, USA*

The 32nd Annual Forum on the Geology of Industrial Minerals will be held in Laramie, Wyoming, in May 1996. The Forum will be held in conjunction with an international trona symposium. Industrial minerals of Wyoming and adjacent areas will be emphasized, and the economics of industrial-mineral production from low-population-density areas with remote markets will also be a topic. Two-day field trips will include a tour of underground trona mines and soda-ash processing plants, and the Wyoming bentonite mining areas and processing facilities. A one-day field trip will be a tour of several industrial-mineral-producing localities in southeastern Wyoming. These include cement production, a granite-aggregate quarry, limestone quarries, Georgia Marble's Wyoming White marble quarry and processing plant, and Sunrise Stone's Wyoming Raven granite quarry and fabricating plant.

The technical sessions will be held on the campus of the University of Wyoming in Laramie. Laramie, with a population of 25,000 including 10,000 University of Wyoming students, is Wyoming's third largest city, and is located at an altitude of 7,200 ft in the Laramie Valley, between the Laramie and Medicine Bow Mountains. In addition to being the home of the University of Wyoming, Laramie is known world-wide as a genuine Wild West location, and is the home of the Wyoming Territorial State Park, the U.S. Marshal's Museum, several restored buildings dating from the vigilante days, and an early 1900s era downtown. Forum participants and their families will be treated to western-theme entertainment including a barbecue-style meal held at the University of Wyoming camp in the Medicine Bow Mountains and an excursion on the Wyoming Colorado Railroad from Laramie to the crest of the Medicine Bow Mountains and return.

Laramie is currently served by United Express that operates several daily round-trip flights to Denver, AMTRAK, and bus lines including the Denver Airport Express. Laramie is 140 mi from Denver and 45 mi from Cheyenne, where rental cars are available. Limited numbers of rental cars are available in Laramie. Participants wishing to rent a car in Laramie are encouraged to make reservations early.

Housing will be available at local motels and on-campus dormitory rooms will be available at a nominal price from the University of Wyoming. The University of Wyoming will provide bus transportation to local motels.

The Wyoming State Geological Survey, as host organization, cordially invites any and all persons interested in the geology of industrial minerals to attend the 1996 Forum in Laramie.

# El Trigésimo Segundo Foro Geológico de Minerales Industriales—Laramie Wyoming, mayo de 1996

El Trigésimo Segundo Foro Geológico de Minerales Industriales tendrá lugar en Laramie, Wyoming, en mayo de 1996. El foro se reunirá junto con un simposio internacional de *trona* (carbonato de sodio calcinado). Se pondrá énfasis en los minerales industriales de Wyoming y regiones vecinas. Otro tema considerará los problemas económicos de la producción de minerales industriales en áreas de Baja densidad de población con mercados remotos. Excursiones de dos días visitarán minas subterráneas de *trona* y plantas de procesamiento de carbonato de sodio calcinado y las minas y plantas de procesamiento de bentonita en Wyoming. Una excursión de un día examinará varias localidades en el sureste de Wyoming donde se producen minerales industriales. Entre éstas hay plantas de cemento, una cantera de agregado de granito, canteras de caliza, la cantera de mármol de la empresa *Georgia Marble* y la cantera de granito y planta de elaboración de la empresa *Sunrise Stone*.

Las sesiones técnicas se llevarán a cabo en el *campus* de la Universidad de Wyoming en Laramie. Laramie es la tercera ciudad de Wyoming y cuenta con una población de 25,000 que incluye 10,000 estudiantes universitarios. La ciudad está a 7,200 pies de altura sobre el nivel del mar, en el Valle de Laramie, entre las *Montañas de Laramie y de Medicine Bow*. Laramie no sólo tiene la Universidad de Wyoming sino también es conocida en todo el mundo como un pueblo que conserva las características del *Wild West*. Así, Laramie tiene el Parque Territorial (*Wyoming Territorial State Park*) y el Museo de la Policía Territorial (*U.S. Marshal's Museum*). Varios edificios reconstruidos datan del tiempo de los vigilantes y la zona céntrica de la ciudad conserva el aspecto de principios del siglo 19. Los participantes del Foro y sus familias serán agasajados con entretenimientos típicos del Oeste de los E.U.A., un asado campéstre en las *Montañas de Medicine*

*Bow* en terreno perteneciente a la Universidad de Wyoming y una excursión en tren del Ferrocarril de Wyoming y Colorado a la cresta de las *Montañas de Medicine Bow*.

Actualmente, se llega a Laramie por avión desde Denver mediante varios vuelos diarios de la empresa *United Express*. Hay servicio de trenes por la empresa *AMTRAK* y hay servicios de omnibus, incluso desde el mismo aeropuerto de Denver (*Denver Airport Express*). Laramie se encuentra a 140 millas de Denver y 45 millas de Cheyenne, donde también se pueden alquilar automóviles. En Laramie mismo hay un número limitado de automóviles de alquiler, por lo cual se recomienda que personas interesadas hagan sus reservas a tiempo.

Se dispondrá de alojamiento en moteles locales; además, la Universidad de Wyoming ofrece habitaciones a precios módicos en sus dormitorios estudiantiles que se encuentran en el mismo *campus*. La Universidad de Wyoming proveerá servicio de ómnibus a los moteles locales para los conferencistas.

En su calidad de anfitrión, el Servicio Geológico de Wyoming extiende una invitación cordial a todas las personas interesadas en la geología de minerales industriales para que asistan al Foro de 1996 en Laramie.

# Quantitative XRD—The minerals make the difference

Randall E. Hughes and Duane M. Moore

*Illinois Geological Survey, 615 E. Peabody Drive, Champaign, Illinois 61820, LISA*

We believe that a lack of sound quantitative procedures in geology continues to distance many of us from *hard* scientists and engineers. Results from five years of methods research demonstrate that quantitative phase analysis (QPA) and quantitative representation (QR, a.k.a., semi-quantitative analysis) should play a much larger role in our work. New grinders, deconvolution programs, and diffractometers allow peak areas to be measured with levels of accuracy and precision comparable to chemical methods. These methods have been used to determine the mineral contents of petroleum reservoir rocks, coals, kaolin and ball clays, and absorbent clays. Our current protocol uses internal standards in random bulk packs to determine percentages of nonclay minerals. Then, reference intensity ratios (RIRs) from the computer program, NEWMOD®, are used to quantify the clay minerals. Loss-on-ignition and XRF chemical analyses provide a check on clay mineral content.

Unexpected benefits of improved quantitative procedures are recognition of (1) the value of QR, (2) the importance of chemical and structural variation in individual minerals, and (3) the absence of amorphous material in geological materials. Of most importance is the quantitative justification for our assertion that *it is minerals*, not chemical oxides, that make the paper smooth, the brick hard, the landfill safe, and the corn grow.

# Análisis cuantitativo por difracción de rayos X (XRD)— los minerales hacen la diferencia

Creemos que la falta de buenos métodos cuantitativos en geología contribuye al desentendimiento entre geólogos por un lado y científicos e ingenieros por el otro. Investigaciones de métodos muestran que el análisis cuantitativo de fases (*quantitative phase analysis (QPA)*) y representación cuantitativa (QR), también llamado análisis semicuantitativo, debieran tener un papel mucho más prominente en nuestro trabajo. Nuevos métodos de molienda, programas de deconvolución y difractómetros permiten que se midan las áreas de picos con exactitud y precisión comparables a las de métodos químicos. Hemos ensayado las técnicas arriba mencionadas para determinar la composición mineral de rocas petrolíferas, carbón, caolín, arcillas de bola (*ball clays*) y arcillas absorbentes. Nuestro protocolo de análisis actual usa patrones internos que consisten de mezclas de grans sin orientación preferencial (*random bulk packs*) para determinar los porcentajes de minerales no arcillosos. Acto seguido, se emplean cocientes de intensidad de referencia (RIR) del programa de computación NEWMOD® para cuantificar los minerales arcillosos. Pérdida por incineración y análisis químicos por fluorescencia de rayos X (XRF) sirven para verificar el contenido de minerales arcillosos.

Beneficios imprevistas de métodos cuantitativos perfeccionados son un reconocimiento de: (1) el valor de QR, (2) la importancia de variaciones químicas y estructurales en minerales individuales y (3) la ausencia de materiales amorfos en materiales geológicos. El beneficio más importante es la justificación cuantitativa de nuestra afirmación que son *minerales* y no óxidos químicos los que hacen liso el papel, duro el ladrillo, estable el relleno de tierra y los que hacen crecer el maíz.

# The Amarillo Texas silica deposit, Texas

Lloyd W. Krumrey, Jr.

*Mining Consultant, 10541 Texwood, El Paso, Texas 79925, USA*

Exploration and development of high-purity silica occurrences within the immediate area of Amarillo, Texas, was began in 1980 with the initial development being completed in 1983. This development comprised raw exploration for high-grade silica deposits, drilling, sampling and analytical testing, and reserve and feasibility studies resulting in the delineation of prime silica target areas.

Due to economic situations within the minerals industry, this project was placed on hold until 1986, when full development was re-initiated on the silica project. The property was grid-surveyed with drill centers every 400 ft. A total of 105 six-inch auger sample holes were drilled at the intersection of each survey mark. The silica was too friable to be held in a core barrel, therefore, the auger was used to collect composite samples of the entire deposit.

The drilling delineated a high-grade silica deposit in excess of 50,000,000 recoverable short tons at an average thickness of the deposit being 60 ft with no overburden. The deposit is adjacent to a major railroad and siding. The average grade of the entire deposit was calculated from sample splits of all the auger drill holes and is as follows:

SiO <sub>2</sub>	97.48%	Fe <sub>2</sub> O <sub>3</sub>	0.14%
MnO	0.006%	BaO	0.13%
TiO <sub>2</sub>	0.12%	CaO	0.26%
K <sub>2</sub> O	0.28%	Cl	0.007%
S	0.017%	P <sub>2</sub> O <sub>5</sub>	0.009%
Al <sub>2</sub> O <sub>3</sub>	1.33%	MgO	0.34%
Na <sub>2</sub> O	0.10%		

Metallurgical testing was undertaken upon completion of the drilling, sampling, analytical testing, and reserve calculations to establish the most economical method to produce a silica product consistently having 99.2% SiO<sub>2</sub> for the general market place and +99.5% SiO<sub>2</sub> for the ultra-high-silica consumers.

The U.S. Bureau of Mines Metallurgical Test Facility located at the University of Alabama at Tuscaloosa, Alabama, was contracted to do initial flotation studies on this silica. The initial testing provided a consistent 99.00–99.30% SiO<sub>2</sub> product. Additional testing was arranged to be accomplished at these facilities resulting in a formulation of the most economical processing method for this silica. The process involved attrition scrubbing of the silica, desliming at minus 200 mesh, and floating the resultant product yielding a consistent 99.30% SiO<sub>2</sub>. The first flotation product was re-attrition scrubbed and deslimed at minus 200 mesh, using the same flotation process produced 99.70% SiO<sub>2</sub> product. The material produced in the pilot plant was submitted for product approval to the Owens Corning Fiberglass facility in Amarillo, Texas, and approved for their usage.

The 330 acres encompassing this silica deposit were purchased in July 1994 by Bill Trout and Lloyd Krumrey, Jr.

## El yacimiento de sílice de Amarillo, Texas

En 1980 se inició la exploración y desarrollo de depósitos de sílice de alta pureza en las cercanías de Amarillo, Texas. Esta fase inicial se completó en 1983 y consistió en reconocimientos expeditivos para localizar depósitos de sílice de elevada calidad, perforaciones, muestreo y análisis de las muestras, reconocimientos en el terreno para determinar reservas y perspectivas de explotación comercial; así quedaron delineadas las áreas de mayor interés.

Debido a las condiciones económicas en la industria mineral este proyecto fue suspendido hasta 1986, cuando se inició el desarrollo pleno. Se marcó en el terreno una red de líneas ortogonales a intervalos de 400 pies con centros de perforación en las intersecciones. Se barrenaron un total de 105 perforaciones de 6 pulgadas de diámetro. La sílice era demasiado friable para obtener testigos. Por esta razón se obtuvieron muestras de sondeo compuestas de cada perforación.

Estos sondeos delinearon un yacimiento de sílice de alta pureza con más de 50,000,000 toneladas cortas (*short tons*) recuperables y un espesor medio de 60 pies, sin sobrecarga. Este yacimiento se encuentra adyacente al ramal de una línea de ferrocarril principal.

La ley media en sílice del yacimiento fue calculada de las muestras de perforación cuarteadas de todas las perforaciones con los resultados siguientes:

SiO <sub>2</sub>	97.48%	Fe <sub>2</sub> O <sub>3</sub>	0.14%
MnO	0.006%	BaO	0.13%
TiO <sub>2</sub>	0.12%	CaO	0.26%
K <sub>2</sub> O	0.28%	Cl	0.007%
S	0.017%	P <sub>2</sub> O <sub>5</sub>	0.009%
Al <sub>2</sub> O <sub>3</sub>	1.33%	MgO	0.34%
Na <sub>2</sub> O	0.10%		



Una vez completada esta fase de exploración inicial, se hicieron ensayos metalúrgicos para determinar el método más económico de producir un producto que tendría una ley del 99.2% de SiO<sub>2</sub> para el mercado general y de +99.5% para consumidores de sílice extra pura.

El Laboratorio Metalúrgico del Servicio de Minas de los E.U.A. (*U.S. Bureau of Mines*) asociado con la Universidad de Alabama en Tuscaloosa fue contratado para hacer estudios iniciales de flotación. Los ensayos iniciales rindieron un producto con una ley consistente de 99.00% a 99.30% de sílice. Ensayos adicionales en el mismo laboratorio desarrollaron el método de refinamiento más económico. El proceso es como sigue: en el primer paso se purifica la sílice por atrición; luego se descalcifica por colado a -200 *mesh*; una primera flotación produce un producto con una ley consistente de 99.3% de SiO<sub>2</sub>. Repitiendo la misma serie de tres pasos de refinamiento se llega a un producto con 99.7% de SiO<sub>2</sub>. El material producido en la planta piloto fue enviado para su aprobación a la fábrica de *fiberglass* de la empresa *Owens Corning* en Amarillo, Texas, y aceptado por ellos para su uso.

En julio de 1994 los 330 acres que abarcan este yacimiento de sílice fueron adquiridos por Bill Trout y Lloyd Krumrey, Jr.

# A comparison of geology and industrial uses of pumice deposits in the Jemez Mountains, New Mexico

Michael A. Linden<sup>1</sup> and Diane N. Tafoya<sup>2</sup>

<sup>1</sup>U.S. Forest Service, Southwestern Region, 517 Gold Avenue SW, Albuquerque, New Mexico 87102, USA;

<sup>2</sup>U.S. Forest Service, Santa Fe National Forest, 1220 St. Francis Drive, Santa Fe, New Mexico 87501, USA

New Mexico is the second largest producer of pumice in the United States. This is due to the Quaternary volcanic rocks of the Jemez Mountains in north-central New Mexico. These volcanics are composed primarily of silicic tuff, air-fall pumice, and rhyolitic flows. The Jemez volcanic sequence gives rise to three pumice blanket deposits of distinctly different character, and the economic value of each is largely determined by these characteristics. The Bandelier Tuff is composed of two rhyolite ash-flow units erupted from the Toledo and Valles volcanic centers, respectively. At the base of each ash flow is an air-fall pumice—the older Guaje Pumice and the younger Tsankawi Pumice. The El Cajete Pumice is part of a younger eruption sequence and makes up the third economically important pumice unit in the Jemez Mountains. Because of their physical differences, the three pumice deposits are processed into very different end-products.

Guaje Pumice is grayish white, subrounded, with fragments generally under 2 cm. The size, color, and lack of staining make it an excellent construction-grade pumice. It is utilized for such "common" uses as an aggregate for building block and concrete, roofing, and landscaping. Buyers skeptical of using colored or stained pumice as a lightweight aggregate fear it will affect the strength of concrete, thus the market determines that unstained pumice is preferable. Guaje Pumice ranges in thickness from 7 to 17 m. It is mined by front-end loaders and loaded as run-of-pit material for minimal screening at an off-site mill. Reserves appear to be substantial.

Tsankawi Pumice is subrounded pinkish lapilli with diameters generally under 1.3 cm. It is mined exclusively to feed a "cinder block" manufacturing plant in which the operator both mines and manufactures the material. Tsankawi Pumice is physically suitable for other construction uses, but its smaller size and pink color make it less desirable on the open market. The bed is relatively thin, ranging from 2 to 8 m in thickness. At the mine it is screened through a single grizzly and then trucked directly to the block manufacturing plant. Tsankawi Pumice was substantially depleted in the 1950s and 60s, and profitable new areas of this deposit are limited.

El Cajete Pumice is grayish white and sub-angular with fragment sizes that can be as large as 25 cm in diameter. Between 30 and 60% of the deposit is composed of fragments larger than 2 cm, which are suitable as stone-wash pumice in the garment-finishing industry. Pumice with this end-use sells for four or more times the price of common construction-grade material. El Cajete Pumice ranges to 24 m in depth, is laterally extensive, and has been mined on a moderate scale only in the last 10 years. Stone-wash pumice is screened at the mine to avoid fragments smaller than 2 cm. The presence of desirable fragment sizes, along with the absence of staining and the volume and homogeneity of the deposit, make this pumice very attractive economically.

## Una comparación de la geología y usos industriales de yacimientos de pómez en las Montañas Jemez, Nuevo México

Nuevo México es el segundo productor de pómez en los E.U.A. Esto se debe a las rocas volcánicas cuaternarias de las Montañas Jemez en el centro-norte del estado. Estas rocas volcánicas consisten principalmente de tobas silíceas, pómez transportado por el aire y corrientes de lava riolítica. La sucesión volcánica de Jemez contiene tres mantos de pómez con propiedades marcadamente diferentes, las que determinan en gran parte su valor económico. La *Toba de Bandelier* consiste de dos unidades de corrientes de ceniza riolítica procedentes, respectivamente, de los centros volcánicos *Toledo y Valles*. En la base de cada una de estas unidades hay una capa de pómez transportada por aire, llamadas, respectivamente, *Pómez de Guaje*, la más antigua, y *Pómez de Tsankawi*. La tercera unidad de pómez que tiene importancia económica en las Montañas Jemez pertenece a una sucesión eruptiva más joven y se llama *Pómez de El Cajete*. Debido a las diferencias en sus propiedades físicas, los productos que se elaboran de estos tres depósitos son muy diferentes.

*Pómez de Guaje* es blanco grisáceo, consiste de fragmentos sub-redondeados, generalmente de menos de 2 centímetros. El tamaño, color y ausencia de manchas hacen que sea un material excelente de construcción. Se lo usa para aplicaciones "comunes" tales como agregado para bloques de edificación y para concreto, techado y modelado de terreno. El mercado prefiere el pómez sin manchas porque ciertos compradores temen que pómez coloreado o manchado disminuye la firmeza del concreto. *Pómez de Guaje* tiene un espesor de 7 a 17 metros. Se lo extrae

mediante cargadores frontales y se despacha tal como sale de la mina para tamizado mínimo en una planta distante de la mina. Las reservas parecen ser considerables.

*Pómez de Tsankavi* consiste de lapilli sub-redondeados, tamaño generalmente menor de 1.3 cm, de color rosáceo. Se lo extrae exclusivamente como materia prima para la fabricación de "bloques de ceniza" en una planta perteneciente a la misma operación minera. Por sus propiedades físicas, *Pómez de Tsankavi* es apto para otros usos de construcción, pero el tamaño más chico y el color rosado hacen que sea menos deseable en el mercado abierto. La capa es relativamente delgada, de 2 a 8 m de espesor. En la mina se lo tamiza por un solo *grizzly* y luego se transporta en camión a la planta. *Pómez de Tsankavi* casi se agotó en los años 1950 y 60. Nuevas áreas económicas de este depósito son limitadas.

*Pómez de El Cajete* es blanco grisáceo, sub-anguloso, con fragmentos de hasta 25 cm. Entre 30 y 60% del yacimiento consisten de fragmentos mayores de 2 cm, útiles para el lavado a la piedra de prendas de vestir. El precio del pómez para este uso es cuatro o más veces mayor que el precio de pómez para construcción. *Núñez de El Cajete* tiene hasta 24 m de espesor, es lateralmente extenso y recién se lo viene extrayendo en cantidades limitadas desde hace 10 años. Pómez para lavado a la piedra es tamizado en la mina para excluir fragmentos más chicos que 2 cm. El tamaño deseable de los fragmentos, la ausencia de manchas y el volumen y homogeneidad del yacimiento hacen que éste sea económicamente muy interesante.

# Alerces: An economic development opportunity— Exploitation of high-quality industrial minerals

Rogelio Martinez, Jorge Perez, and Mauricio Martinez

*Compañía Minera los Alerces, Calle 21 No. 809, Chihuahua, Chihuahua 31000, Mexico*

- Integration of mineral deposits with large reserves and high-grade-ore quality, well-developed shipping routes, and ease of exploitation, positions Alerces for efficient mineral development. From our experience, Alerces today has projects with high potential. These include large calcium carbonate deposits with in-place purity above 90%.

Alerces also has experience in barite production and marketing and has a deposit with high-purity and low mining costs. Our SiO<sub>2</sub> deposits yield different products including: (1) non-angular (rounded) silica sand at —10 +20 and —20 +40 mesh used in filters, and more commonly, (2) proppant or hydraulic-fracturing sand (frac sand). The sand's quality and potential makes it unique in Mexico. The company obtained its main experience mining silica, leading to our interest in related commodities such as cristobalite, volcanic glass, and feldspar.

Alerces is a company interested in reaching production of high-quality minerals. We are also interested in developing technology for value-added products that can easily achieve significant market penetration. We are a company open to exchange of ideas and joint ventures with other companies. Of particular interest to this company is its participation in the North American Free Trade Agreement (NAFTA), because it encourages partnerships with other companies that share similar backgrounds and interests in international mineral developments and productions.

## Alerces: una oportunidad para el desarrollo economico--- explotación de minerales industriales de alta calidad

Alerces presenta una oportunidad para el eficiente desarrollo industrial gracias a la integración de yacimientos minerales de amplias reservas y alta calidad con rutas de transporte bien desarrolladas y facilidad de explotación. Nuestra experiencia demuestra que Alerces ofrece proyectos de potencial elevado, entre los que se cuentan voluminosos depósitos de carbonato de calcio con pureza "in situ" en exceso del 90%.

Alerces también tiene experiencia con la producción y comercialización de barita y trabaja un depósito de alta pureza y bajo costo de explotación. Nuestros depósitos de sílice suministran productos varios, tales como arena de sílice no angular (redondeada) de tamaños -10 +20 y -20 +40 *mesh* usada en filtros, y, más abundante, arenas para fracturamiento hidráulico (*proppant sand* y *frac sand*). Gracias a su calidad y potencial esta arena no tiene par en México. La empresa Alerces ganó su experiencia principalmente en la extracción de sílice, lo cual motiva nuestro interés en la explotación de materiales afines, tales como la cristobalita, el vidrio volcánico y el feldespato.

La compañía Alerces tiene el propósito de producir minerales de alta calidad. También estamos interesados en desarrollar las tecnologías para productos de valor agregado que puedan lograr una penetración importante del mercado. Estamos abiertos al intercambio de ideas y a emprender proyectos cooperativos con otras empresas. En particular, la empresa desea participar en el Acuerdo Norteamericano del Comercio Libre (NAFTA) porque éste fomenta la asociación de compañías con intereses similares en el desarrollo y producción internacionales de recursos minerales.

# Source of diamonds in Ghana, West Africa

David I. Norman<sup>1</sup>, Scott McKittrick<sup>1</sup>, and Henry Appiah<sup>2</sup>

<sup>1</sup>*Department of Earth and Environmental Science, New Mexico Tech 801 Leroy Place, Socorro, New Mexico 87801-4796, USA*

<sup>2</sup>*Department of Geology and Survey, UST School of Mines, Tarkwa, Ghana*

Ghana has been a major producer of small-size (industrial) diamonds from the Akwatia and Tarkwa diamond fields for the past 70 years. Akwatia diamonds have a maximum size of 4 mm and typically are 25 stones / carat (ct), whereas the Tarkwa field produces up to 8 ct stones. Diamonds exceeding 15 ct are reported from the Northern Volta region.

Akwatia diamonds together with minor gold are produced from one to two deep soils and in minor stream drainages near Akwatia. The occurrence of diamonds over several hundred kilometer area prompted speculation that they are extraterrestrial, but exploration drilling has determined that they occur locally in bedrock comprised principally of metaturbidite. Mapping and chemical analyses indicate that the occurrence of metamorphosed kimberlitic intrusions at Akwatia is associated with carbonate alteration bearing gold. Chemical analyses indicate that the diamondiferous turbidite has a large percentage of kimberlitic material. Widespread alteration and shearing associated with the diamond-bearing bedrock thought to be sedimentary suggests sheared kimberlite. Possibly the diamond-bearing units in the turbidite are comprised of kimberlite tuffs. The occurrence of the kimberlite was overlooked in the past because metamorphism has obliterated textures and characteristic minerals.

Mapping occurrences of alluvial diamonds in the Tarkwa district indicates that the immediate source is the Banket Formation of the Tarkwa Group. This formation contains paleo-placer gold deposits that are being exploited at four mines. No primary source of diamonds is known.

Dating of metamorphism and igneous rocks constrains the age of diamond-bearing intrusives to the Birimian (1.9 to 2.1 Ga), soon after Birimian crust was formed. Ghana diamond deposits therefore differ from most others, because they were not associated with significantly older continental crust. Recent weathering and erosion at Akwatia distributed kimberlite-hosted diamonds into nearby soils and stream drainages. An important factor in preservation of Akwatia kimberlite was that it intruded a zone where marine sediments were being deposited. Tarkwa diamonds suggest that other Birimian kimberlites were extruded above sea level. These must have been quickly eroded soon after intrusion with diamonds preserved in ancient sediments. The occurrence of gold together with diamonds may be the result of gold-ore solutions flowing upwards on the same fracture systems that localize kimberlite intrusions.

## Procedencia de diamantes en Ghana, Africa del Oeste

Desde hace 70 años Ghana ha sido un productor importante de diamantes chicos de grado industrial, de los campos de Akwatia y Tarkwa. Los diamantes de Akwatia tienen un tamaño máximo de 4 milímetros y típicamente requieren 25 piedras por quilate; en cambio, el yacimiento de Tarkwa produce diamantes de hasta 8 quilates por piedra y de Volta Norte llegan informes de diamantes que superan los 15 quilates.

Junto con ocurrencias menores de oro los diamantes de Akwatia se encuentran en uno o dos suelos profundos y en los drenajes de arroyos menores cerca de Akwatia. La ocurrencia de diamantes en un área de varios cientos de kilómetros cuadrados dio lugar a la especulación que estos diamantes eran de origen extraterrestre. De perforaciones exploratorias se ha determinado que los diamantes ocurren localmente en estratos compuestos principalmente de metaturbidita. Levantamiento geológico y análisis químicos revelan que, en Akwatia, las intrusiones de kimberlita metamorfozadas están asociadas con carbonatos alterados auríferos. Análisis químicos indican que turbiditas ricas en diamantes contienen un porcentaje elevado de material kimberlítico. Las rocas diamantíferas se consideran de origen sedimentario, pero asociada con ellas se encuentra una extensa alteración y zonas de cizallamiento (*shearing*), lo cual sugiere que en realidad se trata de kimberlita deformada. Es posible que horizontes diamantíferos en las turbiditas consisten de tobas kimberlíticas. La existencia de kimberlita en estos estratos ha pasado por inadvertida porque el metamorfismo ha borrado texturas y minerales característicos.

El relevamiento de ocurrencias de diamantes aluvionales en el distrito de Tarkwa indica que su fuente inmediata es la Formación Banket del Grupo de Tarkwa. Esta formación también contiene antiguos placeres auríferos que se explotan en cuatro minas. No se conoce ninguna fuente primaria de diamantes en esta zona.

Datamiento del metamorfismo y de las rocas ígneas asigna la edad de las intrusiones portadoras de diamantes al Birimiano (1.9 a 2.1 mil millones de años atrás, poco después de que se formó la corteza birimiana). Así es que los depósitos de diamantes de Ghana difieren de la mayoría de los yacimientos en otras partes porque no se hallan asociados con la corteza continental que es bastante más antigua. En Akwatia, la alteración meteórica y erosión recientes han diseminado los diamantes de las kimberlitas a suelos vecinos y drenajes fluviales. Un factor importante para la preservación de la kimberlita de Akwatia es que fue intruida en una zona donde se estaban

depositando sedimentos marinos. Los diamantes de Tarkwa sugieren que otras intrusiones de kimberlita del Birimiano surgieron por arriba del nivel del mar. Es probable que estas rocas fueron rápidamente desnudadas poco después de la intrusión, y los diamantes fueron preservados en los sedimentos antiguos. La presencia de oro junto con diamantes puede ser el resultado de soluciones auríferas que ascendieron por el mismo sistema de fracturas que las intrusiones de kimberlita.

# Some observations on the origin of bentonites

I. Edgar Odom

*American Colloid Company, 1500 West Shure Drive, Arlington Heights, Illinois 60004, USA*

Although bentonites are predominantly composed of the clay mineral montmorillonite, most contain small amounts of igneous minerals, i.e. quartz, feldspar, and mica. In order to understand better the origin of sodium- and calcium-rich bentonites, a study was made of the chemical compositions of feldspar in bentonites from throughout the world. The following are some of the results: (1) a direct relationship exists between the origin of bentonites and plate tectonics, (2) bentonites are formed from sodium-rich glassy volcanic ash or rocks, (3) bentonites having calcium as the dominant exchangeable ion have been exchanged by ground water, and (4) bentonites having sodium as the dominant exchangeable ion (i.e. Wyoming bentonites) occur in shales and in arid areas, or in some paleo-environment that has prevented the exchange of calcium for sodium.

## Algunas observaciones sobre el origen de las bentonitas

Aunque las bentonitas se componen mayormente de montmorillonita, un mineral arcilloso, casi todas tienen además pequeñas cantidades de minerales igneos, tales como cuarzo, feldespato y mica. Para comprender mejor el origen de bentonitas sódicas y cálcicas estudiamos la composición química de feldespatos en bentonitas de todo el mundo. En lo que sigue se presentan algunos resultados: (1) existe un relación directa entre el origen de las bentonitas y la tectónica de placas; (2) las bentonitas se forman de rocas o cenizas volcánicas vitreas ricas en sodio; (3) bentonitas en que predomina el calcio como el iono intercambiable han adquirido esta característica por acción de aguas subterráneas; (4) bentonitas sódicas (por ejemplo las de Wyoming) ocurren en esquistos arcillosos o en zonas de clima arido o en algún paleoambiente que impidió la sustitución del sodio por el calcio.



# The industrial minerals of the Sultanate of Oman

Richard F. Riordan<sup>1</sup> and J. F. Pasquet<sup>2</sup>

<sup>1</sup>R.F. Riordan Consultants, 2674 Robidoux Road, Sandy, Utah 84093-1139, U.S.A.;  
<sup>2</sup>BRGM, B.P. 6009-45060 Orleans Cedex 2, France

The sultanate of Oman is the second largest country on the Arabian Peninsula, with a population of about two million. Oman's economy is dominated by petroleum, with hydrocarbon products accounting for about 90% of export earnings. The Ministry of Petroleum and Minerals (MP&M) has a history of identifying and investigating the mineral deposits of the Sultanate. An example of this activity, designed to diversify the economy, is the modern mining, beneficiation, and smelting of copper by the government-owned Oman Mining Company (OMC).

Operations in the industrial-mineral field include: the Oman Chromite Company established by the government in 1991, which is developing a chromite deposit for eventual export; two cement plants using local limestone, phyllite or shale, and gypsum; a lime plant using a chalky limestone to produce material used in lime-brick and building blocks; several plants using quarried marble and limestone to produce decorative-stone facings and wall and ceiling tiles; a number of crushing and screening plants operating near population centers to produce construction aggregates; and industrial and edible salt produced from oil-field brines.

Additional industrial minerals under study and evaluation for early development include kaolin for ceramic tiles and silica sand for container glass. Both these items are presently imported in large quantities.

Numerous other industrial-mineral deposits and resources are undergoing continuing exploration and evaluation with access and exploitation studies and both domestic and export market development. Location maps and summaries of the reserves and grades of the various described industrial-mineral deposits are identified at the poster presentation.

## Los minerales industriales del Sultanato de Oman

Oman es segundo en tamaño entre los países de la península árabe; la población es de unas dos millones. La economía de Oman está dominada por el petróleo; productos de hidrocarburos representan un 90% de las ganancias de exportación. El Ministerio de Petróleo y Minerales (MP&M) tiene una historia de identificar e investigar los yacimientos minerales del Sultanato. Un ejemplo de esta actividad, que tiene por objeto diversificar la economía, es una operación moderna de minería, refinamiento y fundición de cobre por la Compañía Minera de Oman (*Oman Mining Co. (OMC)*), que pertenece al gobierno.

Otras operaciones en el campo de los minerales industriales son: la Compañía de Cromita de Oman (*Oman Chromite Co.*), establecida por el gobierno en 1991, que está desarrollando un yacimiento de cromita para futura exportación; dos plantas de cemento que usan caliza, filita o esquistos arcillosos y yeso locales; una planta de cal que explota una caliza gredosa para producir ladrillos cálcicos (*lime-brick*) y bloques de construcción; varias plantas que usan mármol y calizas de cantera y producen losa para frentes decorativos, así como baldosas para paredes y techos; un número de plantas ubicadas cerca de centros de población que trituran y tamizan piedra para agregados de construcción; y establecimientos que producen sal industrial y comestible usando como materia prima aguas saladas de los yacimientos petrolíferos.

Otros minerales industriales que están bajo estudio y evaluación para desarrollo próximo incluyen: caolín para baldosas cerámicas y arena silícica para recipientes de vidrio, productos que actualmente se importan en gran cantidad.

Continúa la exploración y evaluación económica de muchos otros yacimientos y recursos de minerales industriales, así como estudios de desarrollo de mercados domésticos y de exportación. Mapas de ubicación y resúmenes de reservas y grados de los yacimientos descritos se dan en la presentación de cartel.

# High-calcium-limestone occurrences and industry in Utah

Bryce T. Tripp

*Utah Geological Survey, 2363 South Foothill Drive, Salt Lake City, Utah 84109, USA*

Commercial deposits of high-calcium limestone in the Basin and Range and middle Rocky Mountains physiographic provinces in western and northern Utah are in Cambrian to Holocene rocks, with deposits most abundant in Cambrian, Devonian, and Mississippian miogeoclinal rocks. These rocks, however, do not generally crop out in the Colorado Plateau physiographic province of eastern Utah, where exposed units are predominantly elastic marine and terrestrial. In the Colorado Plateau units of Pennsylvanian, Permian, Triassic, Jurassic, and Tertiary age only locally contain high-calcium limestone. Although carbonate rocks of Utah have not yet been systematically evaluated, more than 350 available chemical analyses from 38 stratigraphic formations indicate potential for large tonnages of high-calcium limestone.

More than 45 high-calcium-limestone quarries have been established in Utah during the past 150 years. Of these 10 are active, producing limestone for (1) cement raw material, (2) manufacture of masonry lime and quicklime, (3) flue-gas desulfurization, (4) smelter flux, (5) coal-mine rock dust, and (6) crushed stone and riprap. Companies have recently explored for and are developing new quarry sites; a quarry in west-central Utah recently began producing limestone for flue-gas desulfurization at a power plant. Companies have also started the permitting process for two quarries in southeastern Utah, which will produce limestone for flue-gas desulfurization and limestone boulders for riprap.

## Calizas de alto contenido de calcio en Utah y su industrialización

Yacimientos económicos de caliza con alto contenido de calcio se alojan en rocas desde el Cámbrico hasta el Holoceno en las provincias fisiográficas de Bolsonis y Sierras (*Basin and Range*) y Montañas Rocallosas centrales (*middle Rocky Mountains*) en el oeste y norte del estado de Utah. Estas calizas son más abundantes en rocas miogeoclinales del Cámbrico, Devónico y Mississipiano. Esas rocas generalmente no afloran en la provincia fisiográfica del Plateau del Colorado en el este de Utah donde las unidades expuestas son mayormente de origen elástico marino o terrestre. En el Plateau del Colorado, formaciones del Pennsilvaniano, Pérmico, Triásico, Jurásico y Terciario sólo localmente contienen calizas de alto contenido de calcio. En Utah, si bien las rocas de carbonato aún no han sido evaluadas sistemáticamente, hay más de 350 análisis químicos de 38 formaciones estratigráficas los que indican un potencial de elevados tonelajes de calizas altas en calcio.

Durante los 150 años últimos se han establecido más de 45 canteras de tales calizas. De éstas, 10 son activas al presente produciendo caliza (1) como materia prima para cemento, (2) para manufactura de cal de albañilería y cal hidratada (*quicklime*), (3) para la desulfurización de gases de chimenea, (4) para flujo de fundición, (5) para supresión de polvo en minas de carbón y (6) para roca triturada y ripio. Varias compañías recientemente han explorado nuevas canteras y las están poniendo en explotación; una de éstas, en el centro oeste de Utah, hace poco empezó a producir caliza para desulfurización de los gases de chimenea en una planta de electricidad. También se ha empezado el proceso de licenciar dos canteras en el sureste de Utah que producirán caliza para desulfurización de gases de chimenea y para ripio.



## APPENDIX 2

### List of Registrants (Professional)

31st Forum on the Geology of Industrial Minerals  
El Paso, Texas  
April 23-28, 1995

Armando Alatorre  
Fideicomiso de Fomento Minero  
Blvd. Isidro Lopez Z y Av. La Salle  
Saltillo, Coahuila 25240, Mexico  
PH: (52-84) 15-28-29  
FAX: (52-84) 15-37-65

John Alfors  
4337 Vista Way  
Davis, CA 95616-4334, USA  
PH: (916) 756-7582

George Austin  
NM Bureau of Mines & Mineral Resources  
New Mexico Tech  
801 Leroy Place  
Socorro, NM 87801-4796, USA  
PH: (505) 835-5320  
FAX: (505) 835-6333

James Barker  
NM Bureau of Mines & Mineral Resources  
New Mexico Tech  
801 Leroy Place  
Socorro, NM 87801-4796, USA  
PH: (505) 835-5114  
FAX: (505) 835-6333

Aldo Barsotti  
U.S. Geological Survey  
National Center Minerals  
12201 Sun Rise Valley Dr.  
Reston, VA 22092, USA  
PH: (703) 648-4990

Stan Bearden  
New Riverside Ochre Co., Inc.  
P.O. Box 460  
Cartersville, GA 30120, USA  
PH: (404) 382-4568  
FAX: (404) 387-1658

John Beck  
3M/Real Estate and Geology Dept.  
Bldg. 42-8W-06, P.O. Box 33331  
St. Paul, MN 55133-3331, USA  
PH: (612) 778-4842  
FAX: (612) 778-6054

David Beeby  
California Div. of Mines and Geology  
801 K St., MS 12-30  
Sacramento, CA 95814-3531, USA  
PH: (916) 324-1444  
FAX: (916) 445-5718

Marc Bélanger  
Ministere des Ressources Naturelles, Quebec  
5700 4 Avenue Ouest, A-209  
Charlesbourg, Quebec G1H 6R1, Canada  
PH: (418) 646-2632  
FAX: (418) 643-2816

Richard Berg  
Montana Bureau of Mines and Geology  
1300 West Park St., Montana Tech  
Butte, MT 59701-8997, USA  
PH: (406) 496-4172  
FAX: (406) 496-4451

J. Blacic  
ICF Kaiser Engineers, Inc.  
1900 Diamond Dr.  
Los Alamos, NM 87544, USA  
PH: (505) 661-5223  
FAX: (505) 661-5222

Michel Bouchard  
SOQUEM  
2600 Boul. Laurier, Bureau 2500  
Sainte-Foy, Quebec G1V 4M6, Canada  
PH: (418) 658-5400  
FAX: (418) 658-5459

Howard Brown  
Pluess-Staufner, Inc.  
P.O. Box 825  
Lucerne Valley, CA 92356, USA  
PH: (619) 248-7306  
FAX: (619) 248-9115

Dennis Bryan  
Agra Earth and Environmental  
737 East Glendale Ave  
Sparks, NV 89431-6408, USA  
PH: (702) 331-2375  
FAX: (702) 331-4153

Raymond Burchett  
Nebraska Geological Survey  
Conservation and Survey Div.  
117 Nebraska Hall, Univ. of Nebraska  
Lincoln, NE 68588-0517, USA  
PH: (402) 489-1987  
FAX: (402) 472-2410

Donald Carr  
Indiana Geological Survey  
611 N. Walnut Grove  
Bloomington, IN 47405, USA  
PH: (812) 855-1359  
FAX: (812) 855-2862

Ulvi Cetin  
 Dept. of Mineral and Environmental Engineering  
 New Mexico Tech  
 801 Leroy Place  
 Socorro, NM 87801-4796, USA

Richard Chamberlin  
 NM Bureau of Mines & Mineral Resources  
 New Mexico Tech  
 801 Leroy Place  
 Socorro, NM 87801-4796, USA  
 PH: (505) 835-5310  
 FAX: (505) 835-6333

Kenneth Clark  
 Dept. of Geological Sciences  
 Univ. of Texas at El Paso  
 El Paso, TX 79968, USA  
 PH: (915) 747-5843  
 FAX: (915) 747-5073

Otis Clarke  
 Consultant  
 4500 Lakeshore Dr.  
 Northport, AL 35476, USA

Mark Cocker  
 Georgia Geological Survey  
 Environmental Protection Division  
 Rm 400  
 19 Martin Luther King, Jr., Dr., S.W.  
 Atlanta, GA 30334, USA  
 PH: (404) 656-3214  
 FAX: (404) 651-9425

Gregory Cork  
 United States Gypsum Co. #143-4  
 P.O. Box 806278  
 Chicago, IL 60680-4124, USA  
 PH: (312) 606-3895  
 FAX: (312) 606-3890

George Cudahy  
 American Eagle Brick Co.  
 P.O. Box 12786  
 El Paso, TX 79913, USA  
 PH: (505) 589-0700  
 FAX: (505) 589-3071

Peggy Dalheim  
 The Mineral Lab, Inc.  
 2700 Youngfield St., Suite 105  
 Lakewood, CO 80215, USA  
 PH: (303) 232-8708  
 FAX: (303) 232-2033

Frank Daugherty  
 P.O. Box 329  
 Alpine, TX 79831, USA  
 PH: (915) 837-2640  
 FAX: (915) 837-2680

Lyndon Dean  
 Material Service Corporation  
 4226 Lawndale Ave.  
 Lyons, IL 60534, USA  
 PH: (708) 442-4624  
 FAX: (708) 442-0294

Ted Drescher  
 U.S. Bureau of Mines, IFOC  
 P.O. Box 25086, DFC  
 Denver, CO 80225, USA  
 PH: (303) 236-0428 ext 235  
 FAX: (303) 236-0238

Mack Duncan  
 J.M. Huber Corp.  
 P.O. Box 528  
 Wrens, GA 30833, USA  
 PH: (706) 547-2551  
 FAX: (706) 595-8331

George Edwards  
 G.H. Edwards and Assoc.  
 901 W. Water St.  
 Elmira, NY 14905, USA  
 PH: (607) 734-3207  
 FAX: same

Ted Eyde  
 GSA Resources, Inc.  
 7660 N. Business Park Drive  
 Tucson, AZ 85743, USA  
 PH: (602) 744-8845  
 FAX: (602) 744-7770

Francisco Flores  
 Direccion General de Fomento Economico  
 Libertad 1300, Edificio Agustin  
 Chihuahua, Chihuahua, Mexico  
 PH: (52-14) 10-90-30  
 FAX: (52-14) 16-00-32

Campbell Fox  
 R.R. #4 (GB 57)  
 Huntsville, Ontario P0A 1K0, Canada  
 PH: (705) 635-1538

Geoffrey Freeman  
 CCORE  
 P.O. Box 4200  
 St. John's, Newfoundland A1C 5S7, Canada  
 PH: (709) 745-2387  
 FAX: (709) 745-2757

Patrick Freeman  
 St. Cloud Mining Co.  
 P.O. Box 1670  
 Truth or Consequences, NM 87901, USA  
 PH: (505) 743-5215

Anibal Gajardo  
 Servicio Nac. De Geologia y Minería  
 Av. Santa Maria 0104  
 Santiago, Chile  
 PH: (56-2) 737-5050  
 FAX: (56-2) 777-8310

G. Robert Ganis  
Tethys Consultants, Inc.  
2001 N. Front St.  
Harrisburg, PA 17102, USA  
PH: (717) 233-7625  
FAX: (717) 233-5054

Gregorio Garcia  
Dept. of Geological Sciences  
Univ. of Texas at El Paso  
El Paso, TX 79968-0555, USA  
PH: (915) 747-5843  
FAX: (915) 747-5073

Phil Goodell  
Dept. of Geological Sciences  
Univ. of Texas at El Paso  
El Paso, TX 79968, USA

Matthew Goolsby  
Dept. of Earth and Environmental Science  
New Mexico Tech  
801 Leroy Place  
Socorro, NM 87801-4796, USA  
PH: (505) 835-5634

Robert Guilinger  
T-van-F Associates  
3400 S. Lowell Blvd. #1-104  
Denver, CO 80236-2412, USA  
PH: (303) 937-3506  
FAX: same

Ibrahim Gundiler  
NM Bureau of Mines & Mineral Resources  
New Mexico Tech  
801 Leroy Place  
Socorro, NM 87801-4796, USA  
PH: (505) 835-5730  
FAX: (505) 835-6333

Peter Harben  
Peter W. Harben, Inc.  
P.O. Box 800  
Morris, NY 13808, USA  
PH: (607) 263-5070  
FAX: (607) 263-5356

Ray Harris  
Wyoming Geological Survey  
Box 3008, Univ. Station  
Laramie, WY 82071-3008, USA  
PH: (307) 776-2286  
FAX: (307) 766-2605

Mitchell Hart  
Monsanto Company  
P.O. Box 816, Highway 34 North  
Soda Springs, ID 83276, USA  
PH: (208) 547-4300, ext. 274  
FAX: (208) 547-3312

Colin Harvey  
Indiana University  
1005 E. Tenth St.  
Bloomington, IN 47405, USA  
PH: (812) 855-0670  
FAX: (812) 855-7899

Randy Henkle  
Henkle and Associates, Inc.  
230 Finch Way  
Carson City, NV 89704, USA  
PH: (702) 849-1683  
FAX: (702) 849-9578

Rudy Hoagberg  
R.K. Hoagberg Associates, Inc.  
12 South 6th St., #1047  
Minneapolis, MN 55402-1514, USA  
PH: (612) 338-2322  
FAX: (612) 338-5457

Jerry Hoffer  
Dept. of Geological Sciences  
Univ. of Texas at El Paso  
El Paso, TX 79968, USA  
PH: (915) 747-5570  
FAX: (915) 747-5073

Gretchen Hoffman  
NM Bureau of Mines & Mineral Resources  
New Mexico Tech  
801 Leroy Place  
Socorro, NM 87801-4796, USA  
PH: (505) 835-5640  
FAX: (505) 835-6333

Mattheus Holleman  
Fundy Gypsum Company  
P.O. Box 400  
Windsor, Nova Scotia B0N 2T0, Canada  
PH: (902) 798-8079  
FAX: (902) 798-5010

David Holmes  
Holmes Reserves, Ltd.  
12640 West Cedar Drive, Suite B  
Lakewood, CO 80228, USA  
PH: (303) 969-8631  
FAX: (303) 969-8905

David Hopkins  
Baker Refractories  
320 North Baker Rd.  
York, PA 17404, USA  
PH: (717) 792-3683  
FAX: (717) 792-2309

Z. D. Hora  
British Columbia Geological Survey  
3657 Doncaster Drive  
Victoria, BC V8P 3W8, Canada  
PH: (604) 952-0414  
FAX: (604) 952-0381

Randall Hughes  
 Illinois Geological Survey  
 Natural Resources Bldg.  
 615 East Peabody Dr.  
 Champaign, IL 61820, USA  
 PH: (217) 244-0080  
 FAX: (217) 333-2380

Werner Jasper  
 Jasper Mining  
 22891 State Highway 49  
 Auburn, CA 95602, USA  
 PH: (916) 268-0124

Tom Kendall  
 Industrial Minerals  
 16 Lower Marsh  
 London, SE1 7RJ, UK  
 PH: 44 (171) 827-9977  
 FAX: 44 (171) 928-6539

Robert Kirkwood  
 Canada Talc Limited  
 Box 537  
 Marmora, Ontario K0K 2M0, Canada  
 PH: (613) 472-2434  
 FAX: (613) 472-5647

Stephen Kline  
 Center for Energy, Natural Resources, and  
 Environmental Studies  
 Arkansas Technical University  
 Russellville, AR 72801, USA  
 PH: (501) 968-0202  
 FAX: (501) 968-0633

Galen Knutsen  
 U. S. Bureau of Mines  
 P.O. Box 25086, Bldg 20, DFC  
 Denver, CO 80225, USA  
 PH: (303) 236-0421  
 FAX: (303) 236-0238

Frank Kottlowski  
 NM Bureau of Mines & Mineral Resources  
 New Mexico Tech  
 801 Leroy Place  
 Socorro, NM 87801-4796, USA  
 PH: (505) 835-5316  
 FAX: (505) 835-6333

Stan Krukowski  
 Continental Lime, Inc  
 1542 East Buttercup Drive  
 Sandy, UT 84092, USA  
 PH: (801) 262-3942  
 FAX: (801) 264-8039

Lloyd Krumrey  
 Mining Consultant  
 10541 Texwood  
 El Paso, TX 79925, USA  
 PH: (915) 598-8799

A. William Laughlin  
 ICF Kaiser Engineers, Inc.  
 1900 Diamond Dr.  
 Los Alamos, NM 87544, USA  
 PH: (505) 661-5223  
 FAX: (505) 661-5222

Michael Linden  
 U.S. Forest Service  
 517 Gold Ave., SW  
 Albuquerque, NM 87102, USA  
 PH: (505) 842-3158  
 FAX: (505) 842-3800

Edward Lucke  
 U.S. Gypsum  
 P.O. Box 80678  
 Chicago, IL 60680-4124, USA  
 PH: (312) 606-4245  
 FAX: (312) 606-5361

Virgil Lueth  
 NM Bureau of Mines & Mineral Resources  
 New Mexico Tech  
 801 Leroy Place  
 Socorro, NM 87801-4796, USA  
 PH: (505) 835-5140  
 FAX: (505) 835-6333

Kim MacLeod  
 Nova Scotia Dept. of Natural Resources  
 1701 Hollis St., P.O. Box 698  
 3rd Floor, Founders Sq.  
 Halifax, Nova Scotia B3J 2T9, Canada  
 PH: (902) 424-8147  
 FAX: (902) 424-7735

Virgil (Vic) Malone  
 Medusa Aggregates Company  
 880 Corporate Dr., Suite 101  
 Lexington, KY 40503, USA  
 PH: (606) 223-2575  
 FAX: (606) 224-1052

James Maly  
 Jones and Neuse/RMT, Inc.  
 14789 Duanesburg St.  
 El Paso, TX 79927, USA  
 PH: (915) 778-9901  
 FAX: (915) 778-0638

Rogelio Martinez  
 Compania Minera los Alerces  
 Calle 21 No. 809  
 Chihuahua, Chihuahua 31000, Mexico  
 PH: (14) 15-20-68  
 FAX: (14) 15-77-57

W. Noel McAnulty, Jr.  
 W. Noel McAnulty, Jr., Geologist  
 6328 Monarch Drive  
 El Paso, TX 79912, USA  
 PH: (915) 833-5809  
 FAX: (915) 833-5809



A. James McCann  
 SOQUEM  
 2600 Boul. Laurier, Tour Belle Cour,  
 Bureau 2500-5 Etage  
 Ste-Foy, Quebec G1V 4M6, Canada  
 PH: (418) 658-5400  
 FAX: (418) 658-5459

John McGee  
 Blue Circle Aggregates  
 5467 Highway 52  
 Gillsville, GA 30543, USA  
 PH: (404) 484-0376  
 FAX: (404) 482-3218

Virginia McLemore  
 NM Bureau of Mines & Mineral Resources  
 New Mexico Tech  
 801 Leroy Place  
 Socorro, NM 87801-4796, USA  
 PH: (505) 835-5521  
 FAX: (505) 835-6333

Lance Meade  
 Luzenac America, Inc.  
 Stone House P.O. Box 680  
 Windsor, VT 05089, USA  
 PH: (802) 228-8802  
 FAX: (802) 228-8051

Norma Meeks  
 NM Bureau of Mines & Mineral Resources  
 New Mexico Tech  
 801 Leroy Place  
 Socorro, NM 87801-4796, USA  
 PH: (505) 835-5410  
 FAX: (505) 835-6333

John J. (Jay) Moroney  
 NYCO Minerals, Inc.  
 124 Mountain View Drive  
 Willsboro, NY 12996, USA  
 PH: (518) 963-4262  
 FAX: (518) 963-4187

Thomas Newman  
 J.M. Huber Corp.  
 P.O. Box 4005  
 Quincy, IL 62305-4005, USA  
 PH: (217) 224-1100  
 FAX: (217) 224-1140

David Norman  
 Dept. of Earth and Environmental Science  
 New Mexico Tech  
 801 Leroy Place  
 Socorro, NM 87801-4796, USA  
 PH: (505) 835-5404  
 FAX: (505) 835-6436

Bruce O'Connor  
 Georgia Geological Survey  
 Environmental Protection Division  
 Rm 400  
 19 Martin Luther King, Jr., Dr., S.W.  
 Atlanta, GA 30334, USA  
 PH: (404) 657-6130  
 FAX: (404) 657-8379

I. Edgar Odom  
 Consultant  
 P.O. Box 7161  
 Libertyville, IL 60048, USA  
 PH: (708) 604-0442

Sam Pickering, Jr.  
 Industrial Mineral Services, Inc.  
 1414 Twin Pines Lane  
 Macon, GA 31211, USA  
 PH: (912) 743-9323  
 FAX: (912) 745-6623

John Prentice  
 Consultant  
 Eastwood, Great Comberton  
 Pershore, Worcestershire WR10 3DT, UK  
 PH: 01 (386) 710-244

Henry Reed  
 3203 3rd Ave, N. Rm 306  
 Billings, MT 59101, USA  
 PH: (406) 245-8880

Richard Riordan  
 Geomapping Assoc., Ltd.  
 2674 Robidoux Rd.  
 Sandy, UT 84093-1139, USA  
 PH: (801) 943-3062  
 FAX: (801) 943-4110

Anthony Roberts  
 Vulcan Materials Co.  
 P.O. Box 80730  
 Atlanta, GA 30366, USA  
 PH: (404) 454-3669  
 FAX: (404) 458-7891

Abelardo Rodriguez Garza  
 Compania Minera La Roja, S.A. de C.V.  
 301 F Paseo del la Rosita  
 Campestre la Rosita  
 Torreon, Coahuila 27250, Mexico  
 PH: (17) 20-30-82  
 FAX: (17) 20-27-30

Brian Roulston  
 Potash Corp. of Saskatchewan, NB Div.  
 P.O. Box 1489  
 Sussex, New Brunswick E0E 1P0, Canada  
 PH: (506) 433-5445  
 FAX: (506) 433-6617

Ken Santini  
Santini and Associates  
1396 South Ward Way  
Lakewood, CO 80228, USA  
PH: (303) 988-2399  
FAX: (303) 988-2399

Dale Scott  
Ontario Ministry of Natural Res.  
34 Woodhaven Cres.  
Whitby, Ontario L1R 1R6, Canada  
PH: (416) 314-1929  
FAX: (416) 314-1948

Gerald Scott  
T.A.A. Inc.  
P.O. Box 1046  
Van Horn, TX 79855, USA  
PH: (915) 283-2571  
FAX: (915) 283-2923

Nelson Shaffer  
Indiana Geological Survey  
611 N. Walnut Grove  
Bloomington, IN 47405, USA  
PH: (812) 855-2687  
FAX: (812) 855-2862

Roger Sharpe  
United States Gypsum Co. #143-4  
P.O. Box 80678  
Chicago, IL 60680-4124, USA  
PH: (312) 606-3964  
FAX: (312) 606-3890

Steve Sikich  
U.S. Bureau of Mines  
P.O. Box 4863, University of Alabama  
Tuscaloosa, AL 35486-4863, USA  
PH: (205) 752-7211  
FAX: (205) 759-9474

Claudette Simard  
West Virginia Geological Survey  
Mont Chateau Research Center  
P.O. Box 879  
Morgantown, WV 26507-0879, USA  
PH: (304) 594-2331  
FAX: (304) 594-2575

Charles Steuart  
Malvern Minerals Company  
P.O. Box 1238  
Hot Springs, AR 71902, USA  
PH: (501) 623-8893  
FAX: (501) 623-5113

Palmer Sweet  
Virginia Dept. of Mines, Minerals and Energy  
Div. of Mineral Resources  
Natural Res. Bldg., McCormick Rd.  
P.O. Box 5469  
Charlottesville, VA 22905, USA  
PH: (804) 293-5121  
FAX: (804) 293-2239

Diane Tafoya  
U. S. Forest Service  
1220 St. Francis Drive  
Santa Fe, NM 87504, USA  
PH: (505) 988-6965  
FAX: (505) 986-5125

Bobby Timmons  
Timmons Associates  
P.O. Box 50606  
Jacksonville Beach, FL 32240, USA  
PH: (904) 246-4533

Bryce Tripp  
Utah Geological Survey  
2363 South Foothill Dr.  
Salt Lake City, UT 84109-1491, USA  
PH: (801) 467-2864  
FAX: (801) 467-4070

Jerry Turner  
NYCO Minerals, Inc.  
2562 Hollycreek Dr.  
Marietta, GA 30062, USA  
PH: (404) 565-2616

Judy Vaiza  
NM Bureau of Mines & Mineral Resources  
New Mexico Tech  
801 Leroy Place  
Socorro, NM 87801-4796, USA  
PH: (505) 835-5232  
FAX: (505) 835-6333

Doss White  
Lodestone Publications, Inc.  
4001 Windermere Dr.  
Tuscaloosa, AL 35405, USA  
PH: (205) 556-0086

John White  
St. Cloud Mining Co.  
P.O. Box 1670  
Truth or Consequences, NM 87901, USA  
PH: (505) 743-5215

Barrett J. Willaims  
Norfolk Southern Corporation  
185 Spring St. SW  
Atlanta, GA 30303, USA  
PH: (404) 529-1853  
FAX: (404) 529-1057

William Willis  
Weyerhaeuser Company  
810 Whittington Ave.  
Hot Springs, AR 71901, USA  
PH: (501) 624-8426  
FAX: (501) 624-8477

Gerald Wilson  
Little Narrows Gypsum Co.  
RR #1  
Little Narrows, Nova Scotia B0E 1T0, Canada  
PH: (902) 756-2080, ext. 232  
FAX: (902) 756-2493



## Selected conversion factors\*

TO CONVERT	MULTIPLY BY	TO OBTAIN	TO CONVERT	MULTIPLY BY	TO OBTAIN
<b>Length</b>			<b>Pressure stress</b>		
inches, in	2.540	centimeters, cm	lb in <sup>-2</sup> (= lb/in <sup>2</sup> ), psi	$7.03 \times 10^{-2}$	kg cm <sup>-2</sup> (= kg/cm <sup>2</sup> )
feet, ft	$3.048 \times 10^{-1}$	meters, m	lb in <sup>-2</sup>	$6.804 \times 10^{-2}$	atmospheres, atm
yards, yds	$9.144 \times 10^{-1}$	m	lb in <sup>-2</sup>	$6.895 \times 10^3$	newtons (N)/m <sup>2</sup> , N m <sup>-2</sup>
statute miles, mi	1.609	kilometers, km	atm	1.0333	kg cm <sup>-2</sup>
fathoms	1.829	m	atm	$7.6 \times 10^2$	mm of Hg (at 0° C)
angstroms, Å	$1.0 \times 10^{-8}$	cm	inches of Hg (at 0° C)	$3.453 \times 10^{-2}$	kg cm <sup>-2</sup>
Å	$1.0 \times 10^{-4}$	micrometers, µm	bars, b	1.020	kg cm <sup>-2</sup>
<b>Area</b>			b	$1.0 \times 10^6$	dynes cm <sup>-2</sup>
in <sup>2</sup>	6.452	cm <sup>2</sup>	b	$9.869 \times 10^{-1}$	atm
ft <sup>2</sup>	$9.29 \times 10^{-2}$	m <sup>2</sup>	b	$1.0 \times 10^{-1}$	megapascals, MPa
yds <sup>2</sup>	$8.361 \times 10^{-1}$	m <sup>2</sup>	<b>Density</b>		
mi <sup>2</sup>	2.590	km <sup>2</sup>	lb in <sup>-3</sup> (= lb/in <sup>3</sup> )	$2.768 \times 10^1$	gr cm <sup>-3</sup> (= gr/cm <sup>3</sup> )
acres	$4.047 \times 10^3$	m <sup>2</sup>	<b>Viscosity</b>		
acres	$4.047 \times 10^{-1}$	hectares, ha	poises	1.0	gr cm <sup>-1</sup> sec <sup>-1</sup> or dynes cm <sup>-2</sup>
<b>Volume (wet and dry)</b>			<b>Discharge</b>		
in <sup>3</sup>	$1.639 \times 10^1$	cm <sup>3</sup>	U.S. gal min <sup>-1</sup> , gpm	$6.308 \times 10^{-2}$	l sec <sup>-1</sup>
ft <sup>3</sup>	$2.832 \times 10^{-2}$	m <sup>3</sup>	gpm	$6.308 \times 10^{-5}$	m <sup>3</sup> sec <sup>-1</sup>
yds <sup>3</sup>	$7.646 \times 10^{-1}$	m <sup>3</sup>	ft <sup>3</sup> sec <sup>-1</sup>	$2.832 \times 10^{-2}$	m <sup>3</sup> sec <sup>-1</sup>
fluid ounces	$2.957 \times 10^{-2}$	liters, l or L	<b>Hydraulic conductivity</b>		
quarts	$9.463 \times 10^{-1}$	l	U.S. gal day <sup>-1</sup> ft <sup>-2</sup>	$4.720 \times 10^{-7}$	m sec <sup>-1</sup>
U.S. gallons, gal	3.785	l	<b>Permeability</b>		
U.S. gal	$3.785 \times 10^{-3}$	m <sup>3</sup>	darcies	$9.870 \times 10^{-13}$	m <sup>2</sup>
acre-ft	$1.234 \times 10^3$	m <sup>3</sup>	<b>Transmissivity</b>		
barrels (oil), bbl	$1.589 \times 10^{-1}$	m <sup>3</sup>	U.S. gal day <sup>-1</sup> ft <sup>-1</sup>	$1.438 \times 10^{-7}$	m <sup>2</sup> sec <sup>-1</sup>
<b>Weight, mass</b>			U.S. gal min <sup>-1</sup> ft <sup>-1</sup>	$2.072 \times 10^{-1}$	l sec <sup>-1</sup> m <sup>-1</sup>
ounces avoirdupois, avdp	$2.8349 \times 10^1$	grams, gr	<b>Magnetic field intensity</b>		
troy ounces, oz	$3.1103 \times 10^1$	gr	gausses	$1.0 \times 10^5$	gammas
pounds, lb	$4.536 \times 10^{-1}$	kilograms, kg	<b>Energy, heat</b>		
long tons	1.016	metric tons, mt	British thermal units, BTU	$2.52 \times 10^{-1}$	calories, cal
short tons	$9.078 \times 10^{-1}$	mt	BTU	$1.0758 \times 10^2$	kilogram-meters, kgm
oz mt <sup>-1</sup>	$3.43 \times 10^1$	parts per million, ppm	BTU lb <sup>-1</sup>	$5.56 \times 10^{-1}$	cal kg <sup>-1</sup>
<b>Velocity</b>			<b>Temperature</b>		
ft sec <sup>-1</sup> (= ft/sec)	$3.048 \times 10^{-1}$	m sec <sup>-1</sup> (= m/sec)	°C + 273	1.0	°K (Kelvin)
mi hr <sup>-1</sup>	1.6093	km hr <sup>-1</sup>	°C + 17.78	1.8	°F (Fahrenheit)
mi hr <sup>-1</sup>	$4.470 \times 10^{-1}$	m sec <sup>-1</sup>	°F - 32	5/9	°C (Celsius)

\*Divide by the factor number to reverse conversions.

Exponents: for example  $4.047 \times 10^3$  (see acres) = 4,047;  $9.29 \times 10^{-2}$  (see ft<sup>2</sup>) = 0.0929.

*Drafters:* Kathy Glesener  
Rebecca J. Titus

*Editor:* Nancy Gilson

*Typeface:* Palatino

*Presswork:* Miehle Single Color Offset  
Harris Single Color Offset

*Binding:* Perfect bound with softbound cover

*Paper:* Cover on 17-pt. Kivar Text  
on 70-lb White Matte

*Ink:* Cover—PMS 320, 4-color process  
Text—Black  
Plates—1 color process, black

*Quantity:* 1,000