

BULLETIN 95

Geology and Mineral Deposits
of the Gallinas Mountains,
Lincoln and Torrance Counties,
New Mexico

by RALPH M. PERHAC

**STATE BUREAU OF MINES AND MINERAL RESOURCES
NEW MEXICO INSTITUTE OF MINING & TECHNOLOGY
CAMPUS STATION SOCORRO, NEW MEXICO**

THE NEW MEXICO BUREAU OF MINES AND MINERAL RESOURCES

Don H. Baker, Jr., *Director*

Full-Time Staff

JOYCE M. AGUILAR, <i>Stenographer</i>	WILLIAM L. HAWKS, <i>Materials Engineer</i>
WILLIAM E. ARNOLD, <i>Scientific Illustrator</i>	FRANK E. KOTTLOWSKI, Sr. Geol. & Ass't. Dir.
ROSHAN B. BHAPPU, <i>Senior Metallurgist (on lv.)</i>	ALEX. NICHOLSON, <i>Geologist-Editor</i>
ROBERT A. BIEBERMAN, <i>Petroleum Geologist</i>	ROBERT L. PRICE, <i>Draftsman</i>
LYNN A. BRANDVOLD, <i>Assistant Chemist</i>	JACQUES R. RENAULT, <i>Geologist</i>
ELISE BROWER, <i>Assistant Chemist (on lv.)</i>	JOHN W. SHOMAKER, <i>Geologist</i>
RICHARD R. CHAVEZ, <i>Lab. Assistant</i>	JACKIE H. SMITH, <i>Lab. Assistant</i>
LOIS M. DEVLIN, <i>Office Manager</i>	MARILYNN SZYDLOWSKI, <i>Secretary</i>
JO DRAKE, <i>Director's Secretary</i>	ROBERT H. WEBER, <i>Senior Geologist</i>
ROUSSEAU H. FLOWER, <i>Senior Paleontologist</i>	SUE WILKS, <i>Typist</i>
ROY W. FOSTER, <i>Petroleum Geologist</i>	MAX E. WILLARD, <i>Economic Geologist</i>
JUARINE W. WOOLDRIDGE, <i>Editorial Clerk</i>	

Part-Time Staff

MARTHA K. ARNOLD, <i>Editorial Assistant</i>	RUFIE MONTOYA, <i>Dup. Mach. Oper.</i>
GUS BLAISDELL, <i>Public Relations</i>	JOHN REICHE, <i>Instrument Manager</i>
JAMES A. BRIERLEY, <i>Ass't Prof. Biology</i>	RONALD ROMAN, <i>Research Metallurgist</i>
ROBERT LEASE, <i>Geologist</i>	W. KELLY SUMMERS, <i>Geologist</i>
FRANK B. TITUS, <i>Geologist</i>	

Graduate Students

ELISE BROWER, <i>Geochemist</i>	CHE-CHEN LIU, <i>Metallurgist</i>
SAUL ESCALERA, <i>Metallurgist</i>	WALTER H. PIERCE, <i>Geologist</i>
WALTER W. FISHER, <i>Metallurgist</i>	HAIA ROFFMAN, <i>Geochemist</i>
MARSHA KOEHN, <i>Geologist</i>	DAVID A. SCHWAB, <i>Geochemist</i>

Plus more than 35 undergraduate assistants

BULLETIN 95

Geology and Mineral Deposits
of the Gallinas Mountains,
Lincoln and Torrance Counties,
New Mexico

by *RALPH M. PERHAC*
University of Tennessee

1970

STATE BUREAU OF MINES AND MINERAL RESOURCES
NEW MEXICO INSTITUTE OF MINING & TECHNOLOGY
CAMPUS STATION SOCORRO, NEW MEXICO

NEW MEXICO INSTITUTE OF MINING AND TECHNOLOGY
STIRLING A. COLGATE, *President*

STATE BUREAU OF MINES AND MINERAL RESOURCES
DON H. BAKER, JR., *Director*

THE REGENTS

MEMBERS EX OFFICIO

The Honorable David F. Cargo *Governor of New Mexico*
Leonard DeLayo *Superintendent of Public Instruction*

APPOINTED MEMBERS

William G. Abbott *Hobbs*
Henry S. Birdseye *Albuquerque*
Thomas M. Cramer *Carlsbad*
Steve S. Torres, Jr. *Socorro*
Richard M. Zimmerly *Socorro*

For Sale by New Mexico Bureau of Mines and Mineral Resources
Campus Station, Socorro, New Mexico 87801—Price \$3.50

Geologic Research is the Key to Industrial Development

Contents

	<i>Page</i>
ABSTRACT	1
INTRODUCTION	3
Location and accessibility	3
Physiography	3
Quaternary deposits	4
Previous work	5
Acknowledgments	5
PETROLOGY	7
Precambrian rocks	7
Permian sedimentary rocks	8
Abo Formation	8
Yeso Formation	9
Glorieta Sandstone	11
Tertiary igneous rocks	13
Porphyritic latite	13
Porphyritic trachyte and microsyenite	14
Porphyritic trachyte	15
Microsyenite	18
Rhyolite	20
Porphyritic andesite	21
Trachyte breccia	23
Paragenesis of igneous rocks	23
Igneous petrogenesis	24
Porphyritic latite	24
Porphyritic trachyte and microsyenite	25
Rhyolite	25
Porphyritic andesite	26
Trachyte breccia	26
Metamorphism	26
Conclusions	28
Age of the intrusives	30
STRUCTURAL GEOLOGY	31
Domal uplift	31

	<i>Page</i>
Faults	31
Age of the deformation	32
GEOLOGIC HISTORY	33
MINERAL DEPOSITS	35
Fluorite-copper deposits	36
Geology	36
Mineralogy	37
Hypogene minerals	37
Supergene minerals	41
Types of fluorite-copper deposits	41
Breccia zones	41
Fissure veins	42
Iron deposits	42
Geology and mineralogy	42
Types of iron deposits	43
Origin of the ore deposits	44
Paragenesis	44
Fluorite-copper deposits	44
Iron deposits	45
Temperature-depth environment	46
Classification and origin	46
REFERENCES	48
INDEX	50

Illustrations

TABLES

1. Permian stratigraphy of the Gallinas Mountains	7
2. Modes of Yeso sandstones	11
3. Modes of Glorieta sandstones	13
4. Modes of porphyritic trachyte	17
5. Modes of microsyenite	20
6. Modes of rhyolite	22
7. Mineralogy of the fluorite-copper deposits	38

FIGURES

1. Index map showing location of Gallinas Mountains	4
2. Schist pebble in arkose of the Abo Formation	9

3. Photomicrograph of Glorieta orthoquartzite 12

4. Photomicrographs of porphyritic trachyte

 A. Albite phenocryst with orthoclase rim 16

 B. Albite phenocryst with albitized orthoclase rim 17

5. Photomicrograph of microsyenite 19

6. Photomicrograph of porphyritic rhyolite 22

7. Map of Lincoln County showing middle(?) Tertiary intrusives 29

8. Brecciated sandstone at Hilltop claim 36

9. Fluorite-bornite-chalcocite vein in Yeso sandstone 37

10. Photomicrograph of porous fluorite ore 39

11. Paragenesis of fluorite-copper deposits 45

PLATES

1. Geologic map of the Gallinas Mountains *in pocket*
2. Geologic structure sections of the Gallinas Mountains *in pocket*

Abstract

The Gallinas Mountains comprise Lower Permian sedimentary rocks that were intruded by middle (?) Tertiary hypabyssal intrusives. The sedimentary sequence is typically transgressive, grading upward from Abo arkoses through continental feldspathic sandstones of the Yeso Formation into the beach or shallow-water, marine Glorieta orthoquartzites. A southward fades change into lagoonal and marine beds indicates a northward-advancing sea throughout Early Permian time. By middle Permian, the shoreline had migrated from southern New Mexico northward to the vicinity of the Gallinas Mountains.

The Permian beds were uplifted, domed, and faulted by middle (?) Tertiary intrusives, primarily alkalic trachyte and rhyolite laccoliths. Despite extensive igneous activity, contact metamorphism is minor. The presence of these and a number of other similar hypabyssal intrusives in central New Mexico defines a distinct Tertiary subsilicic alkalic intrusive province in this part of the state.

Many iron and fluorite-copper-bastnaesite deposits are associated with the trachyte laccolith. The iron occurs as magnetite-hematite re-placement lodes in Yeso carbonate beds. The fluorite-copper-bastnaesite deposits are typical low-temperature epithermal veins and breccia fillings in Yeso sandstones. Despite the large number of deposits, the economic potential of the Gallinas area is limited. The better iron de-positis have been almost completely exhausted, and, although fluorite, copper minerals, and bastnaesite are common, total reserves of these are small.

Introduction

The Gallinas Mountains form one of the larger domal uplifts in an intrusive belt in central New Mexico. The range is, thus, ideally suited for a study of the igneous geology and of the uplifted Permian sedimentary rocks. Associated with the intrusive activity are many epithermal mineral deposits that lend themselves to a study of the epigenetic mineralization of iron, copper, fluorite, and bastnaesite.

LOCATION AND ACCESSIBILITY

The Gallinas Mountains are in northern Lincoln County, with part of the north flank extending into Torrance County, about 40 miles southeast of the geographic center of New Mexico (fig. 1). The range covers about 50 square miles; however, approximately 80 square miles were mapped within R. 10, 11, 12 E, T. 1 N. and T. 1, 2 S. All but a few square miles of this area is within the Cibola National Forest.

The nearest settlement is Corona, about 12 miles northeast of the mountains on U. S. Highway 54 and on the main line of the Southern Pacific Railway. Carrizozo, the county seat, lies about 45 miles south of the range. Generally, the mountains are easily accessible; most parts are within 2 or 3 miles of a road. Most roads can be travelled in an ordinary automobile, except after heavy rains or snows.

PHYSIOGRAPHY

The Gallinas Mountains* are typical of the small, isolated mountain ranges that rise above the high, semiarid plains of central New Mexico. Gallinas Peak*, the highest point, is at an elevation of 8,637 feet. The surrounding plains range from 6,800 to 7,000 feet; hence, the maximum relief is about 2,000 feet, and the local relief in the mountains ranges from 500 to 1,000 feet. Annual rainfall is 15 to 20 inches, and tree and soil cover, therefore, are fairly extensive above 7,500 feet. The range is well dissected by deep valleys in which flow the ephemeral streams that drain the area. The small stream channels at the eastern base of the range drain eastward to the Pecos River; those on the north drain into Pinos Wells and other closed basins, whereas the drainage on the west and south empties into the Tularosa Basin.

* The terms "Gallinas Mountains" and "Gallinas Peak" are among the many redundant place names in New Mexico. A topographically lower and less prominent mountain range in western Socorro County is also named Gallinas Mountains, and its highest point (elev. 8,442 ft.) is called Gallinas Peak.

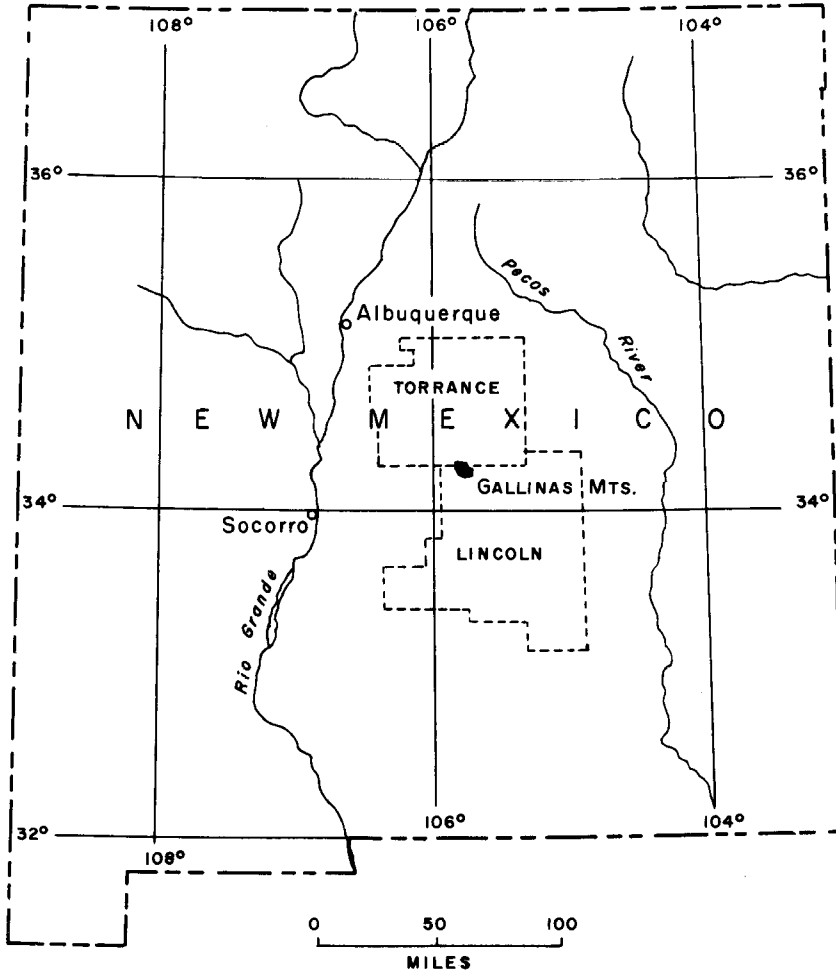

Figure 1
INDEX MAP OF NEW MEXICO SHOWING LOCATION OF GALLINAS
MOUNTAINS

QUATERNARY DEPOSITS

The Quaternary deposits differ considerably from place to place in the Gallinas Mountains area. Essentially, two types of Holocene deposits are present: eluvium on the mountain slopes and alluvial deposits on pediment surfaces and in stream courses. In few places do the Quaternary deposits exceed a few feet in thickness.

The mountain slopes are covered by a thin and extensive layer of soil, mixed with locally derived, poorly sorted, angular rock fragments, that completely obscures the bedrock in many areas. The eluvium is typically less than 3 or 4 feet thick, but may be as much as 15 feet thick in some places.

Although the pediment is mainly a bedrock surface, it is almost completely covered by alluvium that is generally less than 1 foot thick and consists of a poorly sorted mixture of silt, sand, and gravel. The typical bajada deposits commonly associated with pediments occur away from the mountains beyond the report area.

The typical channel alluvium in the stream courses of the mountains and surrounding flats is a poorly sorted mixture of clay and silt with irregular sand and gravel lenses. These deposits are thinner in the mountains than on the flats. Whereas some mountain streams have little or no alluvium, deposits up to 10 feet thick occur beyond the base of the range.

PREVIOUS WORK

The Gallinas Mountains are mentioned only briefly in geologic literature published before World War II. Lindgren noted only the iron mineralization in the district (Lindgren et al., 1910, p. 176). Darton's geologic work in the area (1922, 1928a, 1928b) was mainly reconnaissance in nature. Neither the reports of Johnson (1928) nor of Talmage and Wootton (1937), both of which discuss the fluor spar resources of New Mexico, make any reference to the Gallinas Mountains. Lasky and Wootton (1933) and Anderson (1957) briefly discussed the metallic mineralization in their papers on the metal deposits of New Mexico. A more recent summary of geology and production has been given by Griswold (1959, p. 64-71, 102-104). During World War II, some detailed work was done in the 10-square-mile Red Cloud mining district of the eastern Gallinas Mountains. In 1943 and 1944, the U. S. Geological Survey and the U. S. Bureau of Mines studied some of the fluorite prospects (Soule, 1946; Rothrock, 1946) and iron deposits (Kelley, 1949, p. 171-178). Also at that time, Kelley (1946) mapped the Red Cloud mining district. This present paper gives the results of the first detailed study of the entire Gallinas Mountains, all previous work having been limited to the Red Cloud mining area.

ACKNOWLEDGMENTS

Many persons contributed to this project. In particular, E. W. Heinrich visited the area and spent considerable time discussing the work with the writer. L. B. Kellum and W. S. Motts also made field visits. During the entire course of the study, D. F. Eschman, E. N. Goddard, O. C. Kopp, and F. S. Turneure all made many helpful suggestions.

Field expenses were partly defrayed by grants from the Penrose Bequest of the Geological Society of America (No. 838-59) and the Horace H. Rackham School of Graduate Studies, University of Michigan (Project 239). The Geochemical Laboratory of the Production Research Division of Humble Oil & Refining Company was kind enough to run a K-Ar date on one sample.

Petrology

The high plains of central New Mexico are underlain mainly by nearly horizontal Permian sedimentary rocks that have been deformed locally by Tertiary intrusives. The Gallinas Mountains, one of the larger of the domal uplifts, consist of Precambrian granite overlain by nearly 2,000 feet of Lower Permian strata (table 1) into which were intruded middle Tertiary laccoliths. The sedimentary sequence is typically transgressive, grading upward from continental arkosic conglomerate, through feldspathic sandstones into a nearshore quartzose sandstone. Alkalic and subsilicic rocks characterize the Tertiary igneous activity.

TABLE 1. PERMIAN STRATIGRAPHY OF THE GALLINAS MOUNTAINS, NEW MEXICO

SERIES	FORMATION	APPROXIMATE THICKNESS (feet)	LITHOLOGY
Upper Leonard	Glorieta	250	Quartzose sandstone
Lower Leonard	Yeso	1,500	Mostly fine-grained feldspathic sandstone with minor siltstone, shale, limestone, and dolomitic limestone
Wolfcamp	Abo	150	Arkosic conglomerate, plus ferruginous sandstone and siltstone

The sedimentary strata are unfossiliferous; thus they are dated by lithologic correlation and stratigraphic position. Because of their distinctive lithologies, the Abo and Glorieta formations are easily recognized in central New Mexico. Stratigraphic relationships within the area date the igneous activity only as post-Glorieta. Regional considerations and isotopic age-dating show it to be substantially younger, probably middle Tertiary.

PRECAMBRIAN ROCKS

A granite that underlies the Abo Formation is exposed by faulting at three places in the Gallinas Mountains, all in Red Cloud Canyon: sec. 23, 24, 25, T. 1 S., R. 11 E. The granite is typically light gray, massive, equigranular, and medium to fine grained, locally somewhat aplitic. This rock consists mainly of quartz, microcline, and sodic oligoclase (Ab_{88}). In addition, randomly distributed accessory magnetite, zircon, biotite, sphene, and apatite, plus secondary epidote, sericite, clay, and iron oxides, are visible microscopically.

As the Abo is the oldest formation deposited on the granite, the latter can only be dated in the Gallinas Mountains as pre-Abo (pre-Early Permian). In the absence of any known Paleozoic intrusive period, and by analogy with other areas in the state, this granite is presumed to be Precambrian. The Yeso Formation overlies known Precambrian granite in the Pedernal Hills, about 50 miles north of the Gallinas Mountains. Between these two localities, small granite hills rise above the Permian rocks near Duran, Cedarvale (Rattlesnake Hills), and Corona (Camelton Hill). Although alluvium covers the granite-Permian contact, these hills probably represent inliers from a pre-Abo landmass that existed in this part of the state throughout much of the late Paleozoic (Thompson, 1942, p. 12).

PERMIAN SEDIMENTARY ROCKS

ABO FORMATION

The oldest sedimentary rock in the Gallinas Mountains is a locally conglomeratic basal arkose that lies directly on granite. Its stratigraphic position and distinctive lithology identify it as the Abo Formation of Wolfcampian age. In the Gallinas Mountains, the Abo is probably not less than 75 nor more than 250 feet thick. The upper contact with the Yeso is gradational and has been arbitrarily defined by the complete disappearance of pebbly material, giving the Abo a thickness of about 150 feet (assuming a reasonable constancy in the attitude of the beds).

Petrography—The Abo Formation consists of a basal conglomeratic arkose, overlain by interbedded siltstone, shale, sandstone, and conglomerate, all red and all feldspathic. The basal arkose is only 20 to 40 feet thick, but it is the most distinctive member. In mineral composition, it is essentially granitic, and hand specimens might easily be mistaken for granite but for the presence of rounded quartz pebbles. The clastic texture, however, is readily apparent in thin section. The rock consists of poorly sorted, angular to subangular grains of quartz, pink microcline, white plagioclase, and minor amounts of magnetite, biotite, sphene, and apatite. A clayey matrix makes up less than 10 percent of the rock. In addition to the mineral grains, the arkose contains many granite fragments and pebbles of quartzite and mica schist (fig. 2).

Above the basal arkose the Abo consists of differing proportions of red siltstone and clay, with irregular lenses of red feldspathic sandstone and conglomerate. The sandstones and conglomerates of this upper unit consist of poorly sorted, subrounded grains of quartz and minor amounts of microcline, plagioclase, mica schist, and quartzite fragments, all set in a matrix of hematite and clay. The matrix makes up 15 to 20 percent of the rock. Accessory minerals are magnetite, zircon, sphene, biotite, muscovite, and apatite.

Petrogenesis—The basal arkose is clearly derived from a nearby gra-



Figure 2
SCHIST PEBBLE IN ARKOSE OF THE ABO FORMATION; SEC. 24,
T. 1 S., R. 11 E.

nitic source, as indicated by its lithologic and mineralogic composition and the angularity and poor sorting of the fragments. The rock, therefore, is essentially a *grus*, to which some exotic material, primarily rounded pebbles of quartzite and mica schist, has been added.

The Abo beds above the basal arkose are probably a flood-plain deposit laid down not far from the source area. The irregular lateral and vertical distribution of rock types is characteristic of continental fluvial deposits. Siltstone is the most abundant lithologic type; however, small, irregular lenses of sandstone and conglomerate, possibly representing stream-channel deposits, occur at various horizons. The proximity to the source is indicated by the abundance of conglomerate and by the presence of fresh biotite schist fragments. That the sediment source was to the north is suggested by the outcrops of granite, schist, and quartzite overlain by Yeso strata in the Pederal Hills area.

The Abo was apparently derived from a typical crystalline complex consisting of granite and medium-grade metamorphic rocks. Its overall characteristics preclude derivation from a sedimentary source.

YESO FORMATION

Conformably overlying the Abo beds are the feldspathic sandstones and siltstones of the Yeso Formation of early Leonardian age. The Yeso is both the most extensive and thickest sedimentary unit in this area.

Although the upper contact is clearly marked by the appearance of the distinct Glorieta quartzose sandstone, the lower contact is gradational, and the thickness of the Yeso in the Gallinas Mountains is uncertain. Because of the absence of sufficient strike-and-dip data and the considerable relief, thicknesses can only be estimated from outcrop width and general attitude of the beds. The Yeso is probably not less than 1,000 nor more than 2,300 feet thick; 1,500 feet is assumed to be the most reasonable value.

Petrography—Fine-grained, feldspathic sandstone accounts for more than 90 percent of the Yeso Formation. The remainder is dolomitic limestone, shale, siltstone, and one bed of gypsum, which occurs only at the Red Cliff iron mine at the southern end of the mountains. The paucity of gypsum is atypical of the formation.

Feldspathic sandstone occurs throughout the formation. A typical hand specimen is pink to buff, fine grained, and generally well sorted, with clay-limonite matrix. In addition to the light-colored sandstone, dark-red ferruginous sandstone occurs locally. The thicknesses of individual beds range from less than 1 foot to about 4 feet, the average being about 2 feet. Cross-bedding is observed in places, and at one locality the uppermost Yeso beds show oscillation ripple marks.

Quartz generally constitutes more than 75 percent of the sandstone (table 2). The grains are subrounded and well sorted; grain size ranges from about 0.1 mm to 0.3 mm, averaging about 0.2 mm in diameter. Much quartz shows corrosion effects and secondary overgrowths. Silica occurs also as chert, both interstitially and as distinct clastic grains. Plagioclase and microcline are also present. Plagioclase is irregularly kaolinized and sericitized; microcline exhibits all degrees of argillic alteration. The following accessories are visible microscopically: apatite, calcite, muscovite, zircon, biotite, magnetite, chlorite, rutile, hematite, and limonite. The minor atypical ferruginous sandstone beds in the Yeso have a hematitic cement that may account for as much as 20 percent of the rock.

The upper beds of the Yeso are generally more quartzose and less feldspathic than the lower beds, and the amount of clayey matrix decreases upward. Textural trends are also apparent; the grains are more rounded and better sorted and have more abundant quartz overgrowths higher in the section. In fact, some of the uppermost Yeso sandstones are difficult to distinguish from the overlying Glorieta.

Unfossiliferous limestone and dolomitic limestone are the second most abundant rock types within the Yeso Formation. These carbonates occur at several stratigraphic levels as thin, discontinuous lenses. A typical specimen is gray and consists of calcite and some dolomite, the carbonate content ranging from 96 to 99 percent. At some localities, secondary quartz crystals occur in tiny solution cavities, and trace amounts of pyrite are in some specimens. About half a dozen different

TABLE 2. MODES OF YESO SANDSTONES

	1	2	3	4	5	6	7	8
Quartz	72.8	79.5	90.6	75.0	82.9	72.0	75.1	85.3
Microcline	0.7	0.6	1.0		5.9	10.7	4.5	
Plagioclase	1.4	0.8			2.5	1.8	1.4	
Altered feldspar	16.7	11.4	5.0	16.7				8.7
Chert	0.8	5.9	0.3	0.6	5.6	1.0		0.8
Magnetite	tr	tr	tr	0.8	tr		tr	
Pvrite		tr						
Matrix	7.3	1.9	3.0	6.9	3.1	14.5	19.1	5.2
Accessories	<u>0.3</u>	<u>tr</u>	<u>tr</u>	<u>tr</u>	<u>tr</u>	<u>tr</u>	<u>tr</u>	<u>0.1</u>
	100.0	100.1	99.9	100.0	100.0	100.0	100.1	100.1

Locations of Samples

- | | |
|-------------------------------|-------------------------------|
| 1. sec. 6, T. 1 S., R. 12 E. | 5. sec. 26, T. 1 S., R. 11 E. |
| 2. sec. 1, T. 1 S., R. 11 E. | 6. sec. 5, T. 2 S., R. 12 E. |
| 3. sec. 25, T. 1 N., R. 11 E. | 7. sec. 13, T. 1 S., R. 10 E. |
| 4. sec. 14, T. 1 S., R. 11 E. | 8. sec. 3, T. 2 S., R. 12 E. |

carbonate horizons occur within the Yeso, none of which is continuous. Few individual beds extend for more than a few tens of feet, the one exception being a 3- to 6-foot-thick bed about 40 feet below the Yeso-Glorieta contact. Limestone at this stratigraphic position occurs persistently throughout the Gallinas Mountains, and individual lenses are commonly continuous for hundreds of feet. This upper limestone member of the Yeso is sufficiently widespread to serve as a structural and stratigraphic marker.

Petrogenesis--The origin of the Yeso Formation is discussed below with the petrogenesis of the overlying Glorieta Sandstone.

GLORIETA SANDSTONE

Because of its stratigraphic position and distinctive lithology, the quartzose sandstone that conformably overlies the Yeso is assigned to the Glorieta Sandstone of late Leonardian age. The Glorieta is the upper-most sedimentary unit in the Gallinas Mountains and caps many of the mountain tops. Because part of the formation has been eroded away, the original thickness cannot be measured. The maximum thickness in the Gallinas Mountains is 250 feet on South Mesa; the nearest known complete section is 278 feet near Willard, about 30 miles to the north-west (Needham and Bates, 1943, p. 1664).

Petrography--In the Gallinas Mountains, the Glorieta is an easily recognizable, resistant, white to light-gray orthoquartzite with extremely uniform lithology. It is the best stratigraphic and structural marker in the area.

Quartz forms as much as 97 percent of some specimens (table 3). It occurs as subrounded grains, 2 to 3 mm in diameter, generally with

very good sorting. Clastic grains of altered microcline and plagioclase and of chert are present in small amounts; chert also occurs as cement. In addition, accessory zircon, apatite, muscovite, and magnetite occur in most specimens. The most distinctive feature of this rock is the abundance of quartz overgrowths (fig. 3) that give the rock an interlocking texture and account for its extreme toughness.

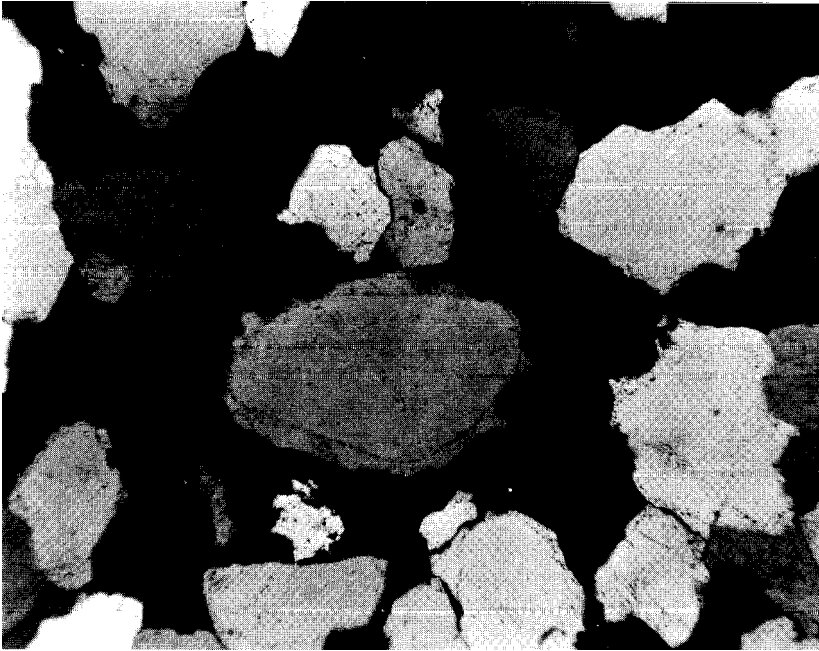

Figure 3

PHOTOMICROGRAPH OF GLORIETA ORTHOQUARTZITE

Quartz grains have prominent quartz overgrowths; specimen from northeast of Rough Mountain (sec. 7, T. 1 S., R. 12 E.); crossed nicols, x65.

The most striking difference between the Yeso and the overlying Glorieta is the quartzitic nature of the latter. The quartz grains in the sandstones of both formations exhibit corrosion and overgrowth phenomena, but the better sorting and lack of matrix of the Glorieta sandstones enabled the overgrowths to form the interlocking texture of an orthoquartzite. As this is typical Glorieta lithology throughout much of New Mexico, the quartz overgrowths are probably unrelated to the igneous activity and deformation in the Gallinas Mountains.

Petrogenesis—According to Needham (1942, p. 36), the Glorieta Sandstone in New Mexico is a marine sand laid down by an advancing

TABLE 3. MODES OF GLORIETA SANDSTONES

	1	2	3
Quartz	92.2	97.2	91.3
Chert	1.6	1.8	1.9
Microcline			0.7
Plagioclase			0.2
Altered Feldspar	5.1	1.1	5.8
Magnetite	1.0	tr	tr
	99.9	100.1	99.9

Locations of Samples

1. sec. 7, T. 1 S., R. 12 E.
2. sec. 12, T. 1 S., R. 11 E.
3. sec. 15, T. 1 S., R. 11 E.

sea. In the Gallinas Mountains, the Glorieta is either a nearshore marine sand or a beach sand and evidently the uppermost preserved unit of a transgressive sedimentary series. The over-all lithology in this area is that of a basal arkose grading upward through feldspathic sandstones into relatively pure quartz sandstone, with noticeably more rounded and better sorted clasts in the upper beds.

The presence of oscillation ripple marks and cross-bedding and the excellent grain-sorting in the uppermost part of the Yeso suggest that it is a beach sand. The cross-bedded Glorieta, therefore, may also be a beach sand, or, possibly, a nearshore marine sand. Such deposits should be expected in the sequence between the basal continental deposits and the marine beds of the San Andres Limestone, which overlie the Glorieta. It is probable that, despite the presence of limestones that represent temporary transgressions, most of the Yeso is nonmarine, with continuous marine deposition beginning during Glorieta time. This conclusion is based on the presence of redbeds, absence of fossils, and the more restricted occurrence of carbonates and evaporites than is typical of the marine and lagoonal Yeso to the south.

The northward facies change from basin carbonates through lagoonal evaporites to nonmarine sandstones indicates that the source area was to the north. The abundance of feldspar and the presence of clastic chert in both the Yeso and Glorieta indicate derivation from both igneous and sedimentary rocks.

TERTIARY IGNEOUS ROCKS

PORPHYRITIC LATITE

Porphyritic latite is found only at Cougar Mountain, a small, isolated mountain northeast of the main part of the Gallinas Mountains. The entire mountain, which covers only about 1.5 square miles, is underlain by this rock. Because the base of the mountain is completely surrounded by alluvium, the contact with the Permian sedimentary

rocks cannot be seen; hence the structural form is indeterminable. However, Yeso beds a few hundred yards west of Cougar Mountain are essentially horizontal and show no change in attitude as the latite is approached; hence the intrusive appears to be a small stock that penetrates at least the uppermost Yeso beds.

Petrography—The rock is distinctive and easily recognized. Hornblende and large, white, subhedral plagioclase phenocrysts are set in a light-gray, aphanitic groundmass that consists almost entirely of orthoclase, minor quartz, and accessories, with sparse subhedral plagioclase. The essential constituents are orthoclase, oligoclase (Ab_{82}), and hornblende. Accessory quartz, magnetite, apatite, zircon, and sphene are present, and alteration has yielded limonite, hematite, clay, and sericite. The approximate composition of the porphyritic latite is:

Oligoclase	47.6%
Orthoclase	43.5
Hornblende	6.0
Quartz	2.1
Magnetite	0.8
Accessories	<u>tr</u>
	100.0%

This composition indicates a $Na_2O + K_2O$ content of about 12 percent. Although plagioclase occurs only sparingly in the groundmass, it is the most abundant mineral because of the large size and abundance of its phenocrysts.

Tabular brown hornblende, up to 5 mm long, occurs almost entirely as phenocrysts that are commonly poikilitic, with abundant plagioclase inclusions. The hornblende is typically limonitized.

The groundmass of the porphyritic latite is almost entirely potash feldspar. Groundmass grains are generally only about 0.2 mm in diameter, whereas the larger phenocrysts may be as much as 10 mm long. Extensive kaolinization of groundmass feldspar makes identification difficult; however, it appears to be orthoclase. The grains are generally subhedral to anhedral and Carlsbad-twinned. Although potash feldspar is restricted almost exclusively to the groundmass, a few Carlsbad-twinned grains occur as phenocrysts. Small amounts of late-crystallized quartz are entirely interstitial. The other minerals are randomly distributed in minor amounts.

PORPHYRITIC TRACHYTE AND MICROSyenITE

One of the most abundant igneous rocks is an alkalic porphyritic trachyte and its associated microsyenite phase. These two types grade into each other and are mineralogically similar; they differ mainly in texture. The four occurrences of microsyenite are randomly distributed and they appear to be lens-shaped bodies, ranging from 400 to 1,200 feet in length, within the larger trachyte mass. Because of the intimate as-

sociation, gradational contact, and mineralogical similarity, the two rocks are considered as one petrologic unit, probably having originated from the same magma.

The trachyte was intruded essentially conformably into the Yeso, the upper intrusive contact generally being 50 to 75 feet below the upper carbonate member of the Yeso. Locally, apophyses from the main intrusive mass intrude the Yeso and Glorieta sandstones at various levels. The trachyte is found only in the southeastern part of the Gallinas Mountains.

The intrusive structure appears to be a laccolith because of (1) the doming of overlying sedimentary rocks, (2) the conformable upper and lower contacts, and (3) the general shape of the body. The top and bottom of the trachyte mass are at constant stratigraphic positions regard-less of elevation, and the body thickens toward the center, from an apparent thickness of 30 feet at the sill-like periphery to more than 500 feet at the center.

Porphyritic Trachyte

Petrography—The porphyritic trachyte is a white to light-gray rock with prominent orthoclase and albite phenocrysts. The rock is holocrystalline porphyritic, with an aphanitic groundmass (fig. 4). Locally, but not typically, the texture is trachytic. Although some phenocrysts are as long as 25 mm, the average dimensions are 1.5 by 3.0 mm. Ground-mass grains are generally 0.1 by 0.15 mm. In thin sills, the grain size is finer, and the groundmass grains are about half the size given above. Alteration is ubiquitous, and noticeable in both hand specimens and thin sections. Fresh feldspars are sparse, and limonite is commonly the only indicator of original mafic minerals.

The rock consists of albite, orthoclase, and minor amounts of hornblende and/or aegirine-augite. Accessory species are: quartz, magnetite, apatite, zircon, rutile, sphene, and ilmenite. In addition, secondary sericite, clay, chlorite, epidote, limonite, and leucoxene are present. Modal analyses of the trachyte are given in Table 4. The averages of these, with the average deviations, are given below:

Orthoclase	67.9±5.6%
Albite (Ab ₉₃)	25.6±4.1
Mafics	3.8±2.8
Quartz	1.3±1.3
Magnetite	1.2±0.9
Accessories	<u>0.1±0.1</u>
	99.9%

These data show that the composition differs considerably. The mafic content, for example, has an average deviation of more than 50 percent; and, although the average quartz content is 1.3 percent, many specimens have no quartz. The modal analyses emphasize the alkalic nature

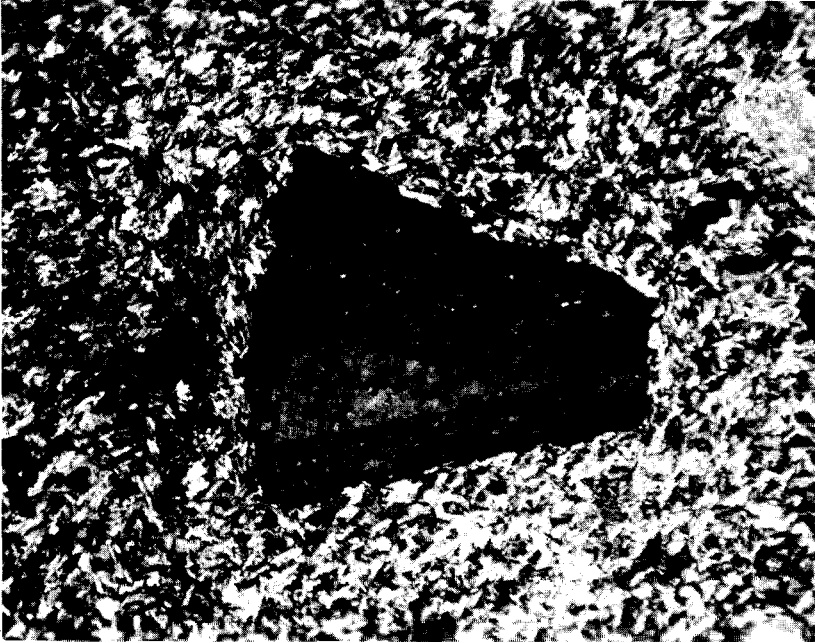

A. Albite phenocryst with orthoclase rim.

Figure 4

PHOTOMICROGRAPHS OF PORPHYRITIC TRACHYTE
Specimens from sec. 31, T. 1 S., R. 12 E.; crossed nicols, x35.

of this rock. The mineralogical composition calculates to a $K_2O + Na_2O$ content of about 14 percent.

The groundmass of the trachyte is composed almost entirely of orthoclase (or its albitized equivalent) and minor quartz (if present at all), plus the accessories. The orthoclase is subhedral to anhedral and commonly Carlsbad-twinned; plagioclase occurs sparingly. The small size, extreme kaolinization, and common albitization make identification of the potash feldspar difficult, but, because the potash feldspar phenocrysts are orthoclase, the groundmass potash feldspar is assumed to be orthoclase as well.

Phenocrysts are either albitized orthoclase or plagioclase rimmed by alkali feldspar (fig. 4). Orthoclase phenocrysts (identified by optic angle) are subhedral to euhedral and show Carlsbad twinning or zonal growth. All are albitized to some extent. Few plagioclase (Ab_{93}) phenocrysts are simply albite; most are rimmed by orthoclase, the thickness of the rims

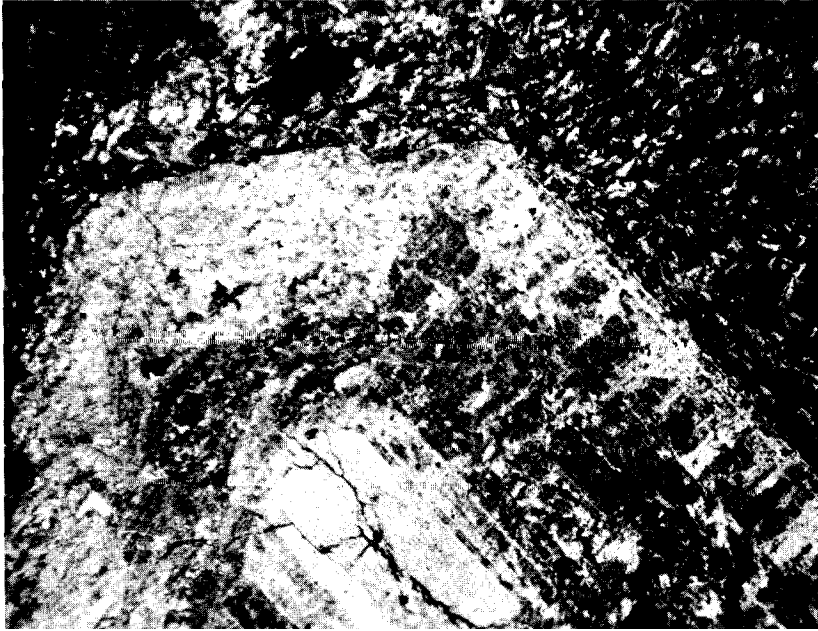

B. Albite phenocryst with albitized orthoclase rim; orthoclase is gray; albite is white.

differing considerably. In some specimens the phenocryst is almost entirely orthoclase with only a small plagioclase core. Both the orthoclase rims on albite and the orthoclase feldspar phenocrysts are albitized.

TABLE 4. MODES OF PORPHYRITIC TRACHYTE

	1	2	3	4	5	6	7	8	9	10	11
Orthoclase	74.2	61.0	69.3	62.5	59.2	64.0	75.3	58.0	73.8	66.1	83.0
Albite	20.4	29.8	28.1	29.9	35.0	26.5	23.4	26.7	23.4	26.7	14.2
Mafics	tr	0.3	1.9	5.0	2.7	7.1	0.9	13.1	2.4	5.3	2.9
Quartz	0.5	7.8	0.3	2.1	2.5				0.1	1.0	
Magnetite	4.8	1.2	0.3	0.6	0.5	2.2	0.2	1.8	0.4	0.9	tr
Apatite	tr	tr	tr	tr	tr	0.2	tr	0.5	tr	tr	tr
Accessories	0.1	tr	tr	tr	tr	0.1	0.2	tr	tr	tr	tr
	100.0	100.1	99.9	100.1	99.9	100.1	100.0	100.1	100.1	100.0	100.1

Locations of Samples

- | | |
|-------------------------------|--------------------------------|
| 1. sec. 7, T. 1 S., R. 12 E. | 7. sec. 18, T. 1 S., R. 12 E. |
| 2. sec. 31, T. 1 S., R. 12 E. | 8. sec. 19, T. 1 S., R. 12 E. |
| 3. sec. 13, T. 1 S., R. 11 E. | 9. sec. 13, T. 1 S., R. 11 E. |
| 4. sec. 31, T. 1 S., R. 12 E. | 10. sec. 23, T. 1 S., R. 11 E. |
| 5. sec. 22, T. 1 S., R. 11 E. | 11. sec. 13, T. 1 S., R. 11 E. |
| 6. sec. 13, T. 1 S., R. 11 E. | |

Phenocrysts are, therefore, represented by two types of feldspars: (1) albitized orthoclase and (2) the more abundant plagioclase with albitized orthoclase overgrowths. Much of the feldspar is thus classed as alkalic feldspar that is a replacement perthitic intergrowth. The percent-age of albite in this perthite ranges from about 19 to 36 percent, averaging about 28 percent. (The modal albite in Table 4 is based on individual albite grains, plus albite occurring as perthite.)

Quartz content ranges from 0 to 8 percent; thus some specimens are actually quartz trachytes. The average amount is about 1.5 percent. The quartz crystallized late as anheda that fill the interstices between earlier crystallized minerals.

The mafic minerals, brown hornblende and/or aegirine-augite, are variable in content and arc represented in many specimens only by limonitized skeletal crystals. Aegirine and primary biotite are scarce. The mafic minerals occur as euhedral to subhedral grains, commonly as phenocrysts, and typically contain inclusions of many of the accessory species.

Magnetite is the most abundant accessory mineral, generally occurring as randomly distributed inclusions within other minerals. Some magnetite is apparently titaniferous, as evidenced by alteration to leucoxene. Minor secondary magnetite, an alteration of pyroxene, also occurs. Tiny euhedra of apatite are ubiquitous. The other accessories occur as subhedral to euhedral grains scattered throughout the rock.

Alteration—Extensive deuteric and hydrothermal alteration is one of the most characteristic features of the porphyritic trachyte. Feldspars are typically albitized, sericitized, and kaolinized, and the minor epidote is apparently a result of feldspar alteration. Some hornblende is altered to biotite, but more commonly it is altered to chlorite and then to iron oxides, as are pyroxene and primary biotite. Some secondary magnetite is also present. Ilmenite is altered to leucoxene. Limonitization of magnetite is common.

Microsyenite

Petrography—The microsyenite is holocrystalline granular, locally porphyritic, but generally equigranular. In hand specimen the rock is white to light gray, distinctly phaneritic, and contains megascopically visible mafic minerals. Average grain size is about 0.2 by 0.4 mm. Phenocrysts are generally about 2.7 by 4.0 mm in size. The rock contains albite, orthoclase, aegirine-augite, and biotite, plus accessory hornblende, magnetite, apatite, rutile, sphene, quartz, zircon, ilmenite, and riebeckite. Modal analyses of five microsyenite specimens are given in Table 5.

Most orthoclase phenocrysts are zoned, and albitization is ubiquitous (fig. 5). Subhedral plagioclase is albite (Ab_{92}), commonly with al-

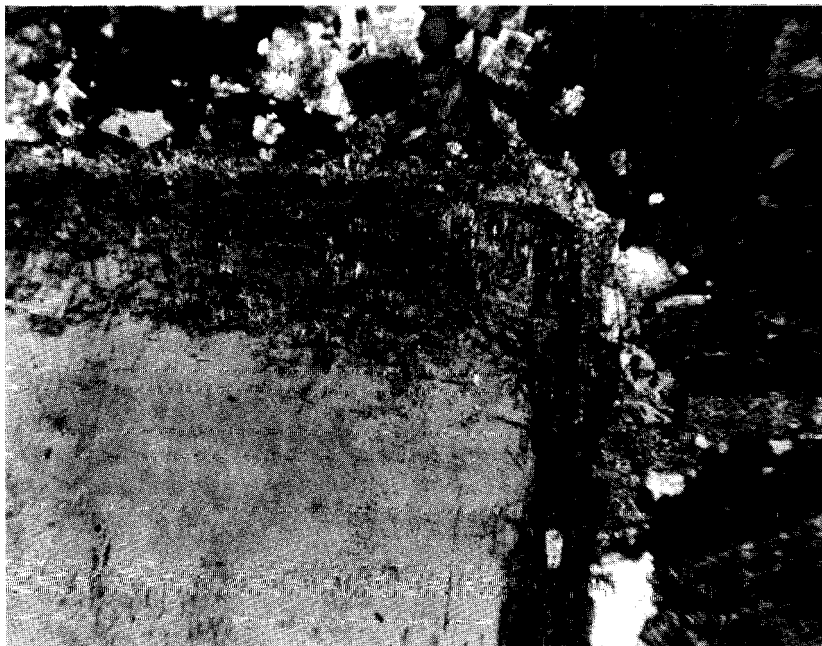

Figure 5

PHOTOMICROGRAPH OF MICROSYENITE

Phenocryst is orthoclase with border albitization; specimen is from northeast Red Cloud road (sec. 18, T. 1 S., R. 12 E.) ; crossed nicols, x35.

bitized orthoclase rims, like those in the porphyritic trachyte. Inclusions of earlier crystallized minerals are common in the feldspars.

In addition to being albitized, feldspars are typically sericitized and kaolinized and locally altered to epidote. A few specimens contain prehnite as small aggregates of radiating, tabular, white crystals (indices of refraction: $N_x = 1.617$, $N_y = 1.620$, $N_z = 1.641$).

Besides the textural difference the microsyenite differs from the porphyritic trachyte by having a greater abundance of mafics (particularly pyroxene). The pyroxene is typically aegirine-augite, although aegirine occurs in some specimens. It is commonly altered to magnetite, biotite, chlorite, and iron oxides. Primary brown biotite is the next most abundant mafic; it occurs as subhedral tabular grains, commonly altered to chlorite. Hornblende is locally present and is altered to chlorite and then to iron oxides. All the mafics have inclusions of accessories.

Magnetite, apatite, and quartz are the most common accessory species. In one specimen, the quartz content exceeds 6 percent, but

TABLE 5. MODES OF MICROSyenite

	1	2	3	4	5
Orthoclase	74.2	64.5	66.8	76.1	68.5
Albite	13.3	22.6	21.3	14.7	21.3
Aegirine	10.9				
Aegirine-augite		2.1	5.7	3.1	1.4
Biotite			4.7		6.0
Hornblende			tr	2.7	tr
Magnetite	0.7	1.8	1.1	2.7	2.0
Quartz		6.7	tr	tr	tr
Accessories	<u>1.0</u>	<u>2.3</u>	<u>0.3</u>	<u>0.8</u>	<u>0.7</u>
	100.1	100.0	99.9	100.1	99.9

Locations of Samples

- | | |
|-------------------------------|-------------------------------|
| 1. sec. 18, T. 1 S., R. 12 E. | 4. sec. 26, T. 1 S., R. 11 E. |
| 2. sec. 11, T. 1 S., R. 11 E. | 5. sec. 2, T. 2 S., R. 11 E. |
| 3. sec. 2, T. 2 S., R. 11 E. | |

quartz is generally absent or occurs only as traces. The presence of tiny, euhedral crystals of riebeckite is interesting because it indicates the alkalic nature of the original magma. The alkalic nature is also evident from the gross mineralogy, which is equivalent to a $\text{Na}_2\text{O} + \text{K}_2\text{O}$ content of about 14 percent.

RHYOLITE

Underlying much of the northwestern part of the Gallinas Mountains is a laccolith of porphyritic leucorhyolite that is structurally like the trachyte laccolith. It was intruded into the uppermost Yeso beds, about 100 to 150 feet below the Yeso-Glorieta contact. Neither the laccolith nor any of its sill-like projections penetrates the Glorieta. However, a narrow dike intrudes the Glorieta in sec. 32, T. 1 N., R. 11 E.

The mass is centered on the vicinity of Gallinas Peak, where the rhyolite is thickest, more than 500 feet. The rhyolite thins rapidly in all directions from this point. For example, southeast of Gallinas Peak (sec. 16, T. 1 S., R. 11 E.), the laccolith thins extremely rapidly and ends abruptly as a thin sill about 5 feet thick. In all other directions, the rhyolite thins to a 20- to 30-foot-thick sill that extends for a considerable distance into the surrounding flat areas (pls. 1, 2). In addition to the main sill, a few small finger-like apophyses from the main laccolith conformably intrude the Yeso Formation at several horizons.

Contact metamorphism is almost completely absent. Only two examples were observed; Yeso sandstone is slightly silicified at one locality, and at another a small, calcareous Yeso xenolith has been converted into a diopside rock. The texture of the rhyolite shows no marked change at the contacts.

Petrography-The typical rhyolite is extremely fine grained, porphy-

ritic, and light colored (white to buff, yellowish brown on weathered surfaces). Most of the equant groundmass grains range from about 0.1 to 0.3 mm in diameter. The microphenocrysts are typically about 0.5 by 1.5 mm in size; however, a few individual feldspars are nearly 10 mm long. Small miarolitic cavities are present locally and are commonly filled with quartz and/or some other mineral (possibly feldspar) that has been altered to kaolinite (identified by x-ray). The feldspar phenocrysts and quartz are the only minerals visible to the naked eye. The rock is most easily identified by the light color, extremely fine-grained texture, and the presence of visible quartz.

Thin sections show that the texture is holocrystalline porphyritic, with an aphanitic groundmass. The rock consists of orthoclase, plagioclase, quartz, and small amounts of magnetite. Biotite is present locally in amounts up to 3 percent. Aegirine and aegirine-augite occur in a few specimens. Accessory species are apatite, sphene, ilmenite, zircon, and muscovite. The secondary minerals are: kaolinite, hematite, limonite, sericite, leucoxene, and rare calcite.

Orthoclase, the most abundant mineral, occurs as small anhedral groundmass grains, commonly Carlsbad-twinned, but a few subhedral phenocrysts are also present. The amount of plagioclase (albite, Ab_{92}) ranges from 4.4 to 26.3 percent (table 6), but is generally less than 15 percent. Plagioclase occurs predominantly as subhedral phenocrysts, but also as anhedral to subhedral groundmass grains. In some specimens groundmass albite is rare. The albite phenocrysts are generally armored by albitized orthoclase (fig. 6), similar to the armoring in the porphyritic trachyte.

Late-crystallized anhedral quartz is entirely interstitial. In some specimens, zonal growth lines are visible in the quartz.

Magnetite is the most abundant accessory mineral. It occurs as subhedral and euhedral grains scattered throughout the rock. The remaining minerals occur in trace amounts except for biotite and aegirine (or aegirine-augite), which locally account for 1 to 3 percent.

The modes (table 6) show that the rhyolites have a wide range in mineral composition; for example, the average deviation of plagioclase exceeds 50 percent. The presence of aegirine and the extensive albitization attest to the alkalic nature of the original magma, and the gross mineralogical composition indicates a $Na_2O + K_2O$ content of about 13 percent. The rock is thus an alkalic porphyritic leucorhyolite.

Alteration—Alteration of the leucorhyolite is virtually identical to that of the porphyritic trachyte (p. 18). All specimens of rhyolite have been affected by both deuteric and hydrothermal alteration.

PORPHYRITIC ANDESITE

A small porphyritic andesite dike that crops out along the road at the head of Red Cloud Canyon intrudes both Yeso beds and porphyritic

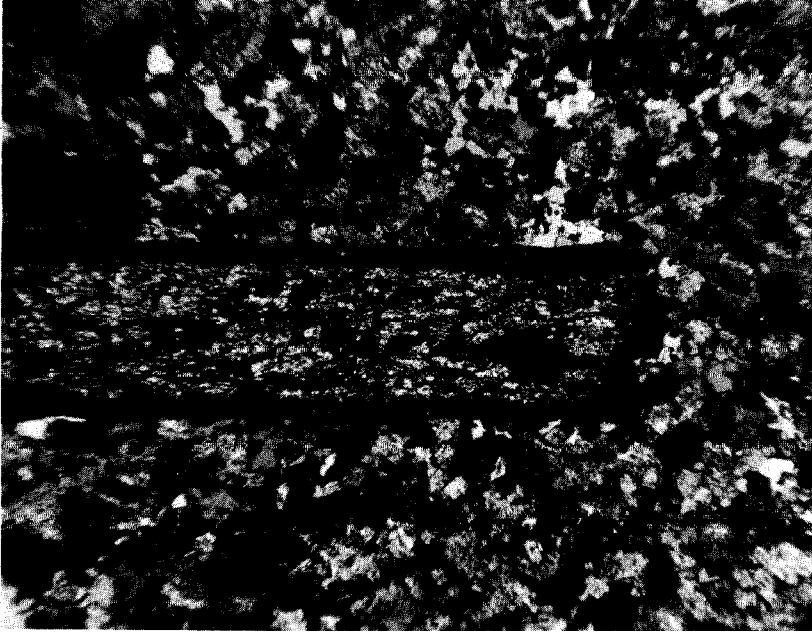

Figure 6
 PHOTOMICROGRAPH OF PORPHYRITIC RHYOLITE
 Phenocryst is albite with orthoclase rim; specimen is from north slope of Gallinas
 Peak (sec. 4, T. 1 S., R. 11 E.) ; crossed nicols, x35.

TABLE 6. MODES OF RHYOLITE

	1	2	3	4	5	6	7	8	9	10	11	12
Orthoclase	59.9	56.3	75.7	73.8	81.1	73.2	74.4	74.0	80.8	77.8	79.7	70.3
Albite	20.6	26.3	10.3	14.9	5.9	6.2	4.4	9.6	7.5	10.7	4.4	17.8
Quartz	17.2	14.4	13.4	10.4	12.0	19.4	20.8	15.2	10.2	8.0	14.1	7.7
Magnetite	2.0	2.9	0.7	1.0	0.7	1.2	0.4	1.2	1.5	1.0	1.8	1.3
Biotite										2.5		3.0
Accessories	<u>0.2</u>	<u>tr</u>	<u>tr</u>	<u>tr</u>	<u>0.2</u>	<u>tr</u>	<u>tr</u>	<u>0.1</u>	<u>tr</u>	<u>tr</u>	<u>tr</u>	<u>tr</u>
	99.9	99.9	100.1	100.1	99.9	100.0	100.0	100.1	100.0	100.0	100.0	100.0

Locations of Samples

- | | |
|-------------------------------|--------------------------------|
| 1. sec. 35, T. 1 N., R. 11 E. | 7. sec. 4, T. 1 S., R. 11 E. |
| 2. sec. 35, T. 1 N., R. 11 E. | 8. sec. 10, T. 1 S., R. 11 E. |
| 3. sec. 3, T. 1 S., R. 11 E. | 9. sec. 9, T. 1 S., R. 11 E. |
| 4. sec. 10, T. 1 S., R. 11 E. | 10. sec. 24, T. 1 S., R. 10 E. |
| 5. sec. 9, T. 1 S., R. 11 E. | 11. sec. 5, T. 1 S., R. 11 E. |
| 6. sec. 4, T. 1 S., R. 11 E. | 12. sec. 24, T. 1 S., R. 10 E. |

trachyte. It is about 5 to 6 feet wide and probably no more than a couple of hundred feet long.

This gray rock is holocrystalline porphyritic, with an aphanitic groundmass. It consists mainly of dark-brown hornblende and andesine (Ab_{56}). The subhedral hornblende and plagioclase are macroscopically visible. The rock contains minor pyroxene (probably pigeonite), with small amounts of quartz that may have been introduced hydrothermally.

The andesite is much altered; andesine is highly sericitized, and abundant chlorite has been derived from alteration of the mafics. Secondary calcite and much limonite are also present.

TRACHYTE BRECCIA

A peculiar brecciated rock occurs at five localities within the Gallinas Mountains, generally in the area of the porphyritic trachyte laccolith. The exact size and shape of these breccia masses cannot be defined for lack of outcrop; however, the plan view seems to be somewhat circular or elliptical, thus suggesting that the bodies may be pipelike. These pipes are fairly small, few exceeding about 75 yards in diameter. The rock itself consists of a trachyte matrix enclosing angular rock fragments that are a fraction of an inch to about 6 inches in size. Most of the fragments are porphyritic trachyte; however, shale, sandstone, lime-stone, andesite(?), and scarce granite are also present. The trachyte of these breccias is like that of the main trachyte laccolith. Except for an apparent concentration near the center, the fragments show no particular arrangement, distribution, or orientation. These bodies are tentatively classed as eruptive breccia pipes.

PARAGENESIS OF THE IGNEOUS ROCKS

All the Gallinas igneous rocks have about the same mineralogy, and the orders of crystallization are nearly identical. The paragenesis for each of the intrusives may be divided into five successive stages: accessory, phenocryst, matrix, deuteritic, and hydrothermal.

The accessory stage is generally represented by crystallization of magnetite, sphene, zircon, and apatite. These species have euhedral shapes and occur as inclusions in other minerals.

Following crystallization of the accessories was formation of the phenocrysts: mafics, albite, and orthoclase. These subhedral grains are typically and commonly embayed by groundmass orthoclase and quartz. Crystallization of the mafic phenocrysts almost certainly began prior to that of the feldspars. In the few thin sections in which mafic phenocrysts were seen in contact with feldspar phenocrysts, the latter commonly embay the former. Albite crystallized before orthoclase, as is indicated by the feldspar phenocrysts that consist of small albite cores with large orthoclase overgrowths.

The matrix stage is represented by crystallization of albite, ortho-

clase, and quartz. Quartz was the last mineral to crystallize and therefore occurs almost exclusively as interstitial anhedral and as filling in some miarolitic cavities. With crystallization of quartz the magmatic stage was essentially completed.

Except for quartz, practically all primary minerals of the igneous rocks are altered. The alteration is ubiquitous and shows no particular geographic distribution. Although the alteration may represent deuteric, hydrothermal, and weathering stages, the three are not clearly definable because some minerals may evolve from more than one type of alteration. Leucoxene and hematite, for example, could result from weathering or hydrothermal alteration, and biotite could be either a magmatic or deuteric mineral. The secondary minerals generally fall into two groups: those that could be primary igneous rock-forming species, and those that have added water and/or oxygen as important constituents. The first group is exemplified by albite, the second by such minerals as sericite and kaolinite. Minerals such as biotite could fit into either group. This grouping serves as an arbitrary means of separating the deuteric and hydrothermal stages of alteration.

Albite is the only positively recognized deuteric mineral because of the extensive albitization that took place toward the end of the magmatic stage. This albitization has converted the orthoclase rims on al-bite phenocrysts to micropertthite. The question arises as to whether these micropertthite rims represent exsolution of albite or albitization of previously crystallized orthoclase. The albite content of the perthite measured in a number of thin sections ranges from about 19 to 36 percent. Even within the same specimen the albite content of the perthite of different grains differs by as much as 13 percent. This variation suggests replacement rather than exsolution. Secondary biotite derived from hornblende and pyroxene may be deuteric or hydrothermal.

The abundance of hydrous secondary minerals attests to the importance of a hydrothermal stage of alteration, best exemplified by the ubiquitous sericitization of plagioclase, the released silica and lime probably having been used in the formation of the minor amounts of epidote and prehnite that occur in some specimens.

The other alteration minerals (leucoxene, hematite, and limonite) probably resulted from weathering. Leucoxene and hematite, however, may also be partly hydrothermal.

IGNEOUS PETROGENESIS

PORPHYRITIC LATITE

A relation between the latite and the trachyte-rhyolite intrusives cannot be positively defined. The two groups have some similarities that suggest consanguinity, such as identical accessories and high $\text{Na}_2\text{O} + \text{K}_2\text{O}$ content. Thus the latite could be a third differentiate from an

original parent magma. Differentiation would necessarily have taken place at considerable depth below the present position of the rocks. The three rocks occur in three distinct and separate places, and the two major units (rhyolite and trachyte) were intruded at approximately the same stratigraphic level, thus vitiating the possibility of gravity differentiation in place.

PORPHYRITIC TRACHYTE AND MICROSyenITE

The texture and mineralogy indicate that the porphyritic trachyte originated from a highly fluid, subsilicic, alkalic magma that solidified at shallow depth—a hypabyssal intrusive. The aphanitic groundmass attests to near-surface cooling, at least during the end stage of consolidation. Three features suggest that the original magma was fairly fluid. The first is the presence of extensive hydrothermal alteration, manifested by ubiquitous kaolin and sericite. Secondly, the greater part of the intrusive occurs as a thin sill over an extensive area. Thirdly, the abundance of hydrothermal mineralization (iron and fluorite) indicates copious quantities of mineralizers in the magma.

Chemically, the magma was subsilicic and alkalic. The rock has a low quartz content and a low mafic-mineral content, which is made up for by a greater content of potash and sodic plagioclase feldspars than is commonly found in calc-alkalic rocks of the syenite clan. Furthermore, the plagioclase is extremely sodic, averaging about Ab_{93} . The accessory minerals are typical of alkalic rocks: zircon, ilmenite, titaniferous magnetite, and abundant apatite. Also, the alkalic nature is reflected by the nearly 14 percent $Na_2O + K_2O$ content calculated from the modes, the presence of sodic pyroxene (aegirine-augite and titaniferous aegirine), and the rare occurrence of riebeckite in the microsyenite phase. Finally, the extensive albitization is certainly a manifestation of a highly sodic magma.

The microsyenite is evidently a phase of the porphyritic trachyte because it everywhere occurs within the trachyte with gradational contacts and is mineralogically similar, although somewhat more mafic. The apparently limited vertical and horizontal extent of the microsyenite suggests lens-shaped bodies that differ from the trachyte mass mainly in texture. This difference may be due to local differences in cooling rate or to locally higher concentrations of volatiles, which, along with the more basic nature of the magma, would decrease viscosity and thus promote growth of larger crystals.

RHYOLITE

Many of the characteristics of the trachyte magma apply equally to the rhyolite magma. The two rocks are similar in all respects except for the higher quartz and lower mafic content of the rhyolite. Like the trachyte, the rhyolite is an alkalic hypabyssal rock that crystallized near

the surface from a highly fluid magma. The consanguinity of these two rocks cannot be doubted; the mafic minerals and the accessories are identical; both rocks have identical phenocryst development; both exhibit extensive albitization and late-stage hydrothermal alteration; and some of the sparse high-quartz trachytes (7.8% quartz) are virtually identical to the low-quartz (10.2%) rhyolites. The two rocks thus differ only in the silica content of the magma. They obviously originated from a common magma that differentiated into siliceous and subsiliceous phases prior to emplacement. Unfortunately, the rocks are nowhere in contact, and age relationships or the scheme of differentiation, emplacement, and crystallization cannot be postulated.

PORPHYRITIC ANDESITE

Because only one outcrop of the porphyritic andesite was seen, little can be said about its origin, and the writer cannot even assert a definite genetic relation between the andesite and the other igneous rocks.

TRACHYTE BRECCIA

The origin of the trachyte breccias is also obscure. Certain features suggest explosive activity. The individual bodies, which have fairly small diameters and may have pipelike shapes, occur in both trachyte and in Yeso sediments. The breccias consist of porphyritic trachyte enclosing randomly distributed and oriented fragments of nearly all other rock types found in the area. The presence of granite fragments indicates that fragments have been carried upward rather than having collapsed into a vent. The formation of these pipes was apparently the last phase of the trachyte igneous activity. Local residual accumulations of volatiles in the trachyte could have been sufficient to yield explosive activity that tore host-rock fragments from the walls of the vents.

METAMORPHISM

Examples of contact metamorphic effects are rare. Even limestones in direct contact with igneous rock typically are neither recrystallized nor metasomatically altered (e. g., unaltered limestone in contact with rhyolite in secs. 8, 16, T. 1 S., R. 11 E.).

In general, the few instances of contact metamorphism occur only at sites of iron mineralization. At the head of Red Cloud Canyon, near an iron prospect, a small limestone lens in trachyte has been silicified. North of Gallinas Peak, at a second iron prospect, a Yeso limestone xenolith (about 50 feet long) in rhyolite has been metasomatically altered to a magnetite-bearing lime-silicate rock composed of tremolite, diopside, calcite, and quartz. At still another iron prospect, south of Red Cloud Canyon, a sandstone has been altered to a quartzitic rock containing minor chlorite and diopside.

Perhaps the best example of contact rocks is at the American iron

mine, where a Yeso sandstone-limestone xenolith is engulfed in porphyritic trachyte. The clay-limonite matrix of the sandstone has been converted to a chlorite-muscovite aggregate, and the carbonate rock has been altered to a skarn consisting of quartz, calcite, and magnetite, plus diopside replacing tremolite; phlogopite is a minor accessory. Because Yeso carbonates have a low silica content, this alteration indicates metasomatic introduction of silica, and probably of iron as well.

The association of diopsidic rocks with rocks containing chlorite-muscovite may seem anomalous because the presence of diopside normally indicates a temperature high enough to convert chlorite and muscovite to biotite. This need not be so. Diopside is generally indicative of at least hornblende hornfels facies conditions; the chlorite-muscovite assemblage is, of course, critical for the albite-epidote hornfels facies.

In lime silicate rocks, diopside can form according to the react ion:

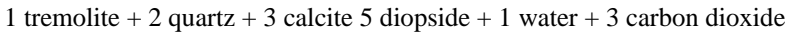

This reaction will go to the right at temperatures of the hornblende hornfels facies. However, the reaction temperature is highly dependent upon CO_2 partial pressure, the lower the CO_2 pressure the lower the temperature of transition. The igneous rocks of the Gallinas Mountains are not deep-seated intrusives; hence sufficient CO_2 could have escaped to permit formation of diopside at a fairly low temperature.

Because of the unpredictability of CO_2 partial pressure, Turner (1958, p. 205) preferred to class the diopside-quartz-calcite assemblage as transitional between the albite-epidote hornfels and hornblende hornfels facies. Thin sections show incomplete replacement of tremolite by diopside, and the assemblage actually consists of tremolite, diopside, quartz, and calcite. This four-phase assemblage suggests disequilibrium conditions, arising, possibly, from the failure to maintain a sufficiently high temperature for a long enough time to eliminate one of the phases. Alternatively, it may be that the over-all temperature was more characteristic of upper albite-epidote hornfels facies conditions rather than of the higher hornblende hornfels facies.

Any estimate of the temperature of the metamorphism is tenuous at best. Turner (1958, p. 237-239) suggested that, at low confining pressure, the transition from albite-epidote to hornblende hornfels facies may occur at temperatures as low as 250° to 300°C . Winkler (1967, p. 30-32), in contrast, preferred a considerably higher temperature, perhaps as high as 400° to 450°C at low CO_2 partial pressure. His data, however, are based on high total pressure (500 and 1,000 bars) and his curves do not extend to low CO_2 partial pressures. Lower total pressure and an extremely low CO_2 partial pressure could easily lower Winkler's plots by as much as 100°C . The metamorphism in the Gallinas Mountains, therefore, could have occurred at temperatures as low as about 300°C .

CONCLUSIONS

The two major igneous rocks in the Gallinas Mountains, trachyte and rhyolite, are distinctly alkalic. Except for the rhyolite, all igneous rocks in the area are subsilicic. In volume, the trachyte is apparently somewhat more abundant than the others, followed by rhyolite and latite. The original magma may, therefore, have had a composition similar to but more siliceous than that of the trachyte. Latite, being the most basic of the three, may have been the first differentiate from the parental magma, then trachyte and rhyolite, respectively. Differentiation at depth would necessitate inception of crystallization and fractionation prior to emplacement. This could partly account for the pronounced porphyritic texture of the rocks, but, because of the apparent high fluidity of the magma, crystallization could not have been too far advanced prior to emplacement.

The depth beneath the surface at which the magmas were intruded cannot be evaluated accurately. In the Gallinas Mountains, the intrusives are overlain by about 250 feet of Permian rocks. Surrounding the range, an additional 50 feet of Glorieta is present, plus about 500 to 700 feet of the overlying Permian San Andres Limestone. The post-San Andres thickness is uncertain. Budding (1964, p. 82-83) estimated the Upper Permian (Bernal Formation) and Mesozoic section to be about 1,775 to 1,900 feet thick in the Jicarilla Mountains, about 25 miles south-southeast of the Gallinas range. Kottowski (1963, p. 73) reported up to 1,850 feet of Cretaceous rocks about 10 miles northeast of Carrizozo. It appears, therefore, that the magmas were emplaced beneath a sedimentary cover that was perhaps 2,500 to 3,700 feet thick.

Subsilicic alkalic stocks and hypabyssals are typical of a number of intrusives in Lincoln County (fig. 7). Sills, dikes, and laccoliths of diorite and syenite occur in the Tecolote Hills, 10 miles south of the Gallinas Mountains (Rawson, 1957), and they contain albitized orthoclase rims on plagioclase identical to those of the Gallinas Mountains igneous rocks. The Jicarilla Mountains are underlain by alkalic rocks (mainly monzonite) occurring as stocks and hypabyssals (Budding, 1964, p. 84). Paws Mountain, south of the Jicarillas, exposes trachyte that contains plagioclase rimmed by potash feldspar (Budding, 1964, p. 84). A syenite body, that could be a laccolith or a stock with sill-like apophyses, occurs at Lone Mountain (Walker and Osterwald, 1956). Again, the feldspar phenocrysts are rimmed by albitized (?) orthoclase, as are the phenocrysts from other nearby intrusives to the north. Although not subsilicic, the Capitan aplite was apparently intruded as a laccolith (Kelley, 1949, p. 144, 149). Similarly, Carrizo Mountain is a granitic laccolith (Kelley and Thompson, 1964, p. 115). In southern Lincoln County, the Cerro Blanco (Sierra Blanca Peak) area exposes a number of intrusives that are mainly subsilicic, alkalic syenites and monzonites (Weber, 1964, p.

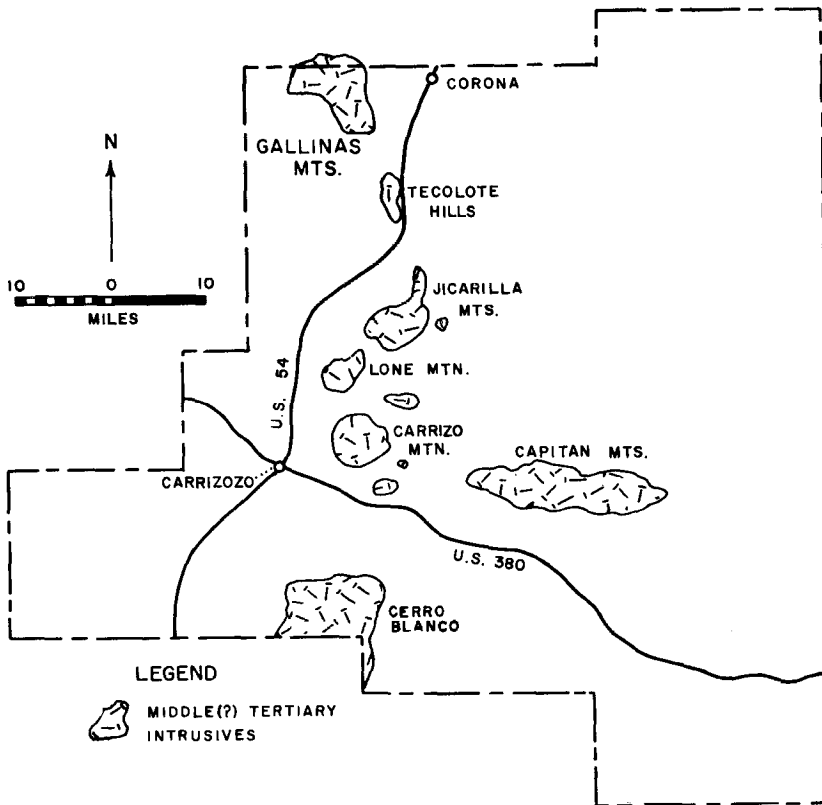

Figure 7
MAP OF LINCOLN COUNTY SHOWING MIDDLE(?) TERTIARY INTRUSIVES

106). Finally, alkalic syenite dikes occur in the Willow, Cub, and Chavez areas a few miles west of Cerro Blanco (Weber, 1964, p. 106). The brief descriptions given above show that the Lincoln County intrusives have some striking similarities. Hypabyssals, including laccoliths, abound, and many, if not most, of the intrusives are subsilicic and alkalic. The alkalic nature of the magmas in Lincoln County is also emphasized by the extensive alkali metasomatism of the dike swarms near Capitan (Elston and Snider, 1964). It appears, therefore, that the oc-

currence of these intrusions defines a distinct subsilicic, alkalic province in this part of central New Mexico.

AGE OF THE INTRUSIVES

Neither the absolute nor relative ages of the intrusive rocks can be given precisely. None of the three major units (latite, trachyte, and rhyolite) is in cross-cutting relation with either of the others. If these three rocks originated from a common parent magma, theoretically, because of its more basic nature, the latite should have differentiated first, followed by trachyte and rhyolite, respectively. These three may be considered as one intrusive group. The breccia bodies and the andesite in-truck the porphyritic trachyte and are therefore younger.

Because the youngest unit cut by the intrusives is the Glorieta, the igneous activity can be dated positively only as post-early middle Permian. The igneous rocks, however, are almost certainly post-Middle Cretaceous because similar intrusives deform the Dakota Sandstone at Tecolote Hills (Rawson, 1957) and near Lone Mountain, 10 and 40 miles, respectively, to the south.

Only one radiometric date was run on a Gallinas Mountains rock. A K-Ar date of 29.9 million years was obtained on an orthoclase phenocryst from the trachyte in sec. 30, T. 1 S., R. 12 E. Because orthoclase is not ideally suited for dating, the value is, at best, a minimum. It compares well, however, with dates obtained on samples from the Cerrillos Hills (near Albuquerque) and from Sierra Blanca (near Ruidoso). In fact, a number of intrusives in the central counties of New Mexico have been dated in the range of about 26 to 37 million years (Kottlowski, Weber, and Willard, 1969). The Gallinas Mountains intrusives, therefore, are probably middle Tertiary (Oligocene) in age.

Structural Geology

DOMAL UPLIFT

The Gallinas range is a faulted, double domal uplift that comprises two laccoliths and associated sedimentary strata. One laccolith is of rhyolite and is centered in the vicinity of Gallinas Peak; the other is of trachyte and is centered near the north end of Rattlesnake Ridge. In each instance the structural high is also the topographic high, and the sedimentary strata dip quaquaversally from these central points. The crest of the trachyte laccolith is capped by horizontal strata; the flanking strata have an average dip between 10 and 15 degrees, with local dips of as much as 45 degrees. The crest of the rhyolite laccolith is barren of sedimentary rocks and the flanking beds have an average dip of about 10 degrees. Both domes are therefore gentle uplifts.

The intrusive contacts everywhere parallel the bedding of the overlying strata. At a few places the igneous rocks show faint foliation, and in each case the foliation is conformable with the attitude of the overlying sedimentary rocks.

It may be argued that the rhyolite mass is a stock centered on Gallinas Peak, with a widespread sill-like apophysis intruded into the Yeso sediments. The writer, nevertheless, favors a laccolithic interpretation because of the general conformability of the intrusive with the sedimentary rocks and the absence of cross-cutting relations.

FAULTS

Faults in the Gallinas Mountains are common, probably more so than is apparent. Although gouge, breccia zones, and slickensides are exposed in some mines, few fault-plane features can be seen at the surface, and displacement data cannot be measured. Most of the larger faults are indicated by stratigraphic discontinuity, such as by the juxtaposition of Precambrian granite against Yeso beds at the north end of one branch of the fault in Red Cloud Canyon (sec. 21, T. 1 S., R. 11 E.); this fault is also indicated by a sparse occurrence of breccia and slickensides.

Although faults appear to be more abundant in the area of the trachyte than in the rhyolite area (pl. 1), this difference may be more apparent than real. The fact that fewer sedimentary rocks are present in the northwestern, rhyolite, part of the mountains reduces the likelihood of seeing a stratigraphic discontinuity, and the almost complete absence of mines lessens the possibility of seeing fault-plane features under-ground.

That most major faults probably dip steeply is indicated by the steep dips of the mine faults and of the few slickensided surfaces that

were seen. Estimates of strike-slip components of movement are not possible, but such movement is suggested by the orientation of striae on slickensided surfaces and the occurrence of some open, steeply dip-ping, locally mineralized cross fractures that may be tension cracks. Most faults are, therefore, probably high-angle normal faults with an indeterminable strike-slip component. Such faulting is compatible with vertical uplift.

The faults generally strike either northwestward or northeastward. The Gallinas Mountains structure is somewhat elliptical, with the major axis trending northwestward. The major faults parallel this axis, indicating a primary tensional force acting in a northeast-southwest direction. A lesser tensional force acted orthogonally, thereby producing the northeastward-trending fracture system.

AGE OF THE DEFORMATION

Stratigraphically, the age of deformation can be dated positively only as post-Glorieta, as the Glorieta Sandstone is the youngest sedimentary unit in the area and is deformed. By analogy with other areas (p. 34), however, the doming and faulting are almost certainly post-Dakota, and probably as young as middle Tertiary (Oligocene).

Geologic History

The exposures of Precambrian granite and the presence of granite and schist pebbles in the Abo indicate that the central New Mexico Precambrian terrain was underlain by a granitic-metamorphic complex. At the close of the Precambrian, erosion apparently reduced much of the land surface to a peneplain (Kelley, 1955, p. 102). Subsequent subsidence resulted in the deposition of marine strata over much of the state during the Paleozoic. By Permian time, however, much of central New Mexico was a land area on which continental clastics (Abo Formation) were being deposited. One of the largest of the late Paleozoic positive areas was the Pederal landmass, which extended from the present Estancia Valley to the Pecos River and as far south as the Sacramento Mountains and included the Gallinas Mountains area.

The continental environment of the Gallinas Mountains area probably persisted until late Yeso time, when rapid marine encroachment began from the south. Despite the presence of some limestone lenses and the one observed gypsum bed, the Yeso Formation is dominantly a continental deposit; the marine sediments constitute less than 10 percent of the unit. Clastic beach sands in the uppermost Yeso suggest a shift to nearshore conditions. These beach sands grade upward into the well-sorted quartzose Glorieta Sandstone that marks the advent of marine conditions, which then continued throughout middle Permian time when the marine limestones of the San Andres Formation were deposited. The Gallinas Mountains section ends near the top of the Glorieta, but the overlying San Andres beds are presented in surrounding areas.

Throughout much of Early and middle Permian time, New Mexico was being covered by a northward advancing sea, with occasional retreats (Hills, 1942). Practically all nonmarine beds in the Gallinas Mountains are represented to the south by marine equivalents, which transgressed progressively northward through Early and middle Permian time. For example, the southern New Mexico equivalent of the Abo is the marine Hueco Limestone; the continental middle Yeso beds of the Gallinas Mountains area are represented immediately south of the range by gypsiferous Yeso; still farther southward, the Yeso is more calcareous and less gypsiferous (less lagoonal and more shelflike in character). These middle Yeso lagoonal and shelf beds grade southward into the basin-facies Bone Springs Limestone of the Delaware basin. The shore-line was in the vicinity of the southern Sacramento Mountains (where Abo interfingers with Hueco) in Wolfcampian time and may have advanced to the area of the Gallinas Mountains by late Yeso time. With the advent of late Leonardian time, the Gallinas landmass was completely submerged by the marine advance.

Mesozoic beds were probably deposited in the area, but were removed by later erosion. Mesozoic rocks occur in similar mountain areas only 10 to 15 miles to the south. The next recognizable event is the igneous intrusion and domal uplift and faulting that is probably as young as middle Tertiary.

Radioactive dates indicate that much igneous activity occurred in central New Mexico during middle Tertiary time. Such activity would fall between the Laramide and Basin and Range disturbances.

On the other hand, certain features suggest that the diastrophism of the Gallinas Mountains, despite its probable middle Tertiary age, may represent a waning phase of the Laramide orogeny. Firstly, Laramide deformation is progressively younger from north to south—Late Cretaceous in parts of northern United States but Tertiary in the Southwest. Middle Tertiary orogenic activity, therefore, could still be related to the Laramide. Secondly, the type of diastrophism in the Gallinas Mountains area is similar to that of the Laramide. Whereas block faulting and limited igneous intrusion typify Basin and Range deformation, the Laramide is characterized by folding and doming, thrusting, and extensive igneous intrusion accompanied by epigenetic mineralization. Despite the presence of normal faults in the Gallinas Mountains, the central New Mexico intrusive area has many characteristics of the Laramide orogeny.

Finally, the nature and location of the intrusions suggest a Laramide affinity. At least four distinct intrusive areas occur near the eastern limit of the Rocky Mountains deformed belt: (1) the Montana petrographic province (Larsen, 1940), (2) a porphyry intrusive belt striking north-eastward across the Front Range of Colorado (Lovering and Goddard, 1950), (3) the central New Mexico intrusive belt, and (4) the intrusives in the Big Bend of Texas (Lonsdale, 1940). These four areas have a number of common features: geographically they flank the eastern Rocky Mountains frontal zone; the intrusives are typically hypabyssal; laccoliths are common, except in Colorado; mineral deposits are associated with many of the intrusives; alkalic and subsilicic types are abundant. The Montana and Colorado belts are Laramide (early Tertiary) in age, and, because of their similar characteristics, the New Mexico and Texas belts may also be related to the Laramide orogeny, despite their apparent middle Tertiary age. The central New Mexico intrusives may be considered as a late phase of Laramide deformation or as part of a distinct post-Laramide, middle Tertiary period of igneous activity.

Mineral Deposits

The Red Cloud district of the eastern Gallinas Mountains contains many small mineral deposits that have been mined for iron, copper, lead, silver, gold, fluorite, and bastnaesite. Altogether, the district has 29 mines or prospects, the locations of the more important ones being shown on Plate 1. Four are copper properties, five are iron, and the remaining twenty were mined or prospected primarily for fluorite. Twenty-three of the properties were studied in detail. The six not examined are either insignificant or inaccessible. Except for assessment work, all properties are now idle.

Most workings are just north of the Red Cloud Canyon dirt road. The district is about 5 miles west of U. S. Highway 54 and about 6 miles west-northwest of the Gallinas siding of the Southern Pacific Railway, and is thus conveniently located.

Whereas most adits are accessible, most shafts are inaccessible due to caving, removal of ladders, headframes, and shaft timbers, or destruction by a forest fire in 1948. In general, the underground workings are unsafe.

The mineral deposits are of two types: iron and fluorite-copper. The iron deposits occur only in limestone near an intrusive contact and are geologically distinct from the other mineral occurrences. The copper and fluorite deposits, however, are basically alike, the only difference being in relative tenor of copper minerals and fluorite; all copper deposits contain considerable fluorite, and practically all fluorite deposits contain some copper minerals. The small amounts of gold, silver, and lead produced were recovered from the copper-fluorite deposits.

The Gallinas Mountains were first prospected about 1885, apparently for copper and lead. Iron was known as early as 1904 (Jones, 1904, p. 179), but was little worked until World War II. Although the first fluorite claims were staked sometime between 1930 and 1935, the actual discovery date of this mineral is not known. In 1943, the rare-earth carbonate bastnaesite was discovered in the Red Cloud Fluorite mine.

Most mining activity occurred in the early 1920's and during the middle and late 1940's. Production details for the district are given by Anderson (1957), Griswold (1959), and Kelley (1949). About 3,500 tons of Pb-Cu-Ag ore was shipped between 1920 and 1949, mostly from the Red Cloud Copper mine. Between 1953 and 1955, probably no more than 2,000 tons of fluorite was shipped from the Rio Tinto, All American, and Red Cloud Fluorite mines. The fluorspar yielded about 60 tons of bastnaesite concentrate. About 10,500 tons of iron ore, assaying about 51 percent iron, was shipped from the Red Cliff and American mines during 1942 and 1943.

FLUORITE-COPPER DEPOSITS

GEOLOGY

The fluorite-copper deposits of the Pride No. 2 and M and E No. 13 prospects are entirely in porphyritic trachyte. All others occur in Yeso sandstones and siltstones, although locally a trachyte dike or sill near a deposit may be mineralized. Fluorite and copper minerals (chalcocite, bornite, malachite, azurite, and chrysocolla) typically occur as breccia and fissure fillings (figs. 8, 9). Where mineralization is particularly in-



Figure 8

BRECCIATED SANDSTONE AT HILLTOP CLAIM

Fluorite (dark) occurs as a filling between the breccia fragments; SE 1/4 sec. 24,
T. 1 S., R. 11 E.

tense, not only are the open spaces filled but the wall rock and breccia fragments are replaced to some extent.

Wall-rock alteration at fluorite-copper deposits is limited to one or two places where minor silicification appears to have affected the adjacent Yeso sandstones. Also, small amounts of pyrite occur locally in the wall rock up to 3 or 4 inches away from a vein. These phenomena, however, are uncommon.



Figure 9
FLUORITE-BORNITE-CHALCOCITE VEIN IN YESO SANDSTONE
Vein (dark streak) is in back of the Little Wonder adit; NW 1/4 sec.
19, T. 1 S., R. 12 E.

MINERALOGY

Hypogene Minerals

The mineralogy of the deposits is summarized in Table 7. Fluorite is the most abundant mineral in all deposits, even in those that were worked primarily for copper. Barite or quartz are generally the next most abundant species. Pyrite, although a minor component, is ubiquitous. Every deposit contains these four primary minerals. Bastnaesite

was found in every deposit except the Red Cloud Copper, Little Wonder, and Summit. Because these prospects are near bastnaesite-bearing

TABLE 7. MINERALOGY OF THE FLUORITE-COPPER DEPOSITS*

	1	2,3	4	5	7	8	9	10	11	12	13	14	16	17	18	19	20	
Fluorite	X	x	x	x	X	x	x	X	x	X	x	x	x	x	x	x	x	
Quartz	M	t	m	m	m	m	t	m	M	m	m	t	m	m	x	m	m	
Barite	x	x	t	m	M	M	M	M	m	M	m	m	m	m	m	M	m	
Bastnaesite	m			t	t	t	m	t	t	t	t	t	t	t	t	t	t	
Calcite	t	t	t	t						t	M	t	m		m	t		
Chalcedony													t		t			
Pyrite	t	t	t	m	t	t	m	t	t	t	t	t	t	t	t	t	t	
Galena		m	t			t							t	m			m	
Bornite		t	t		t									t				
Chalcocite		m	M		t								t	t				
Limonite	t	t	t	t	t	t	t	t	t	t	t	t	t	t	t	t	t	
Hematite	t	t	t	t	t	t	t	t	t	t	t	t	t	t	t	t	t	
Pyromorphite		t	t								t				t			
Cerussite		?												m		t		
Anglesite			t											t			t	
Chrysocolla		m	m		t						t	t	t		t			
Malachite		t	t		t						t	t	t		t			
Azurite		t	t								t	t	t					
X > 50%		1.	Red Cloud Fluorite							11.	Summit							
x — 25 — 50%		2, 3.	Red Cloud Copper and Deadwood							12.	Hoosier Girl North							
M = 10 — 25%									13.	Hoosier Girl South								
m = 5 — 10%		4.	Little Wonder							14.	Eureka							
t — < 5%		5.	Last Chance							16.	Rio Tinto							
		7.	Eagle Nest							17.	All American							
		8.	Bottleneck							18.	Sky High							
		9.	Congress							19.	Pride No. 2							
		10.	Conqueror No. 4 and Hilltop							20.	M and E No. 13							

* Deposit numbers correspond to location numbers on Plate 1.

deposits, the mineral is undoubtedly present but too sparse to have been observed in the few samples studied. Some deposits, such as the Summit prospect, are mineralogically simple and comprise only four hypogene minerals: quartz, fluorite, barite, and pyrite. In contrast, the Rio Tinto deposit comprises at least nine hypogene minerals and many supergene species. Although most deposits contain at least traces of the copper sulfides bornite and chalcocite, oxidation is so advanced in some that the only copper minerals present are azurite, malachite, and especially chrysocolla. Galena and its alteration products (cerussite, anglesite, and pyromorphite) occur in some deposits.

Fluorite, the most abundant mineral, typically occurs as a fine-grained aggregate, filling open spaces and irregularly replacing the wall rock. Although pale-green and white crystals occur at a few deposits,

nearly all fluorite is medium to dark purple. The fluorite does not fluoresce, although it does exhibit thermoluminescence in shades of very pale yellow. Despite the dark-purple color, few specimens exhibit radio-activity that exceeds twice background. Where bastnaesite crystals are present, they are surrounded by dark-purple halos of fluorite (fig. 10).

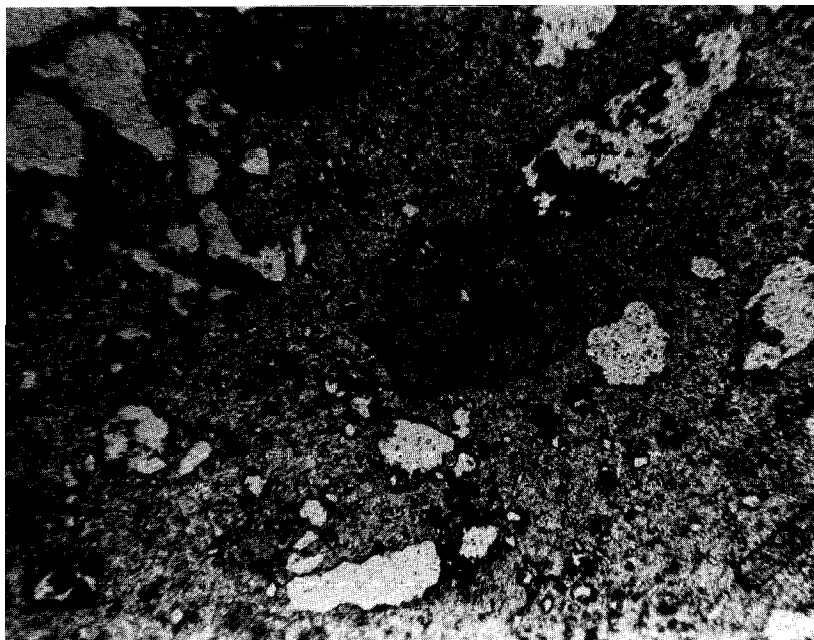

Figure 10

PHOTOMICROGRAPH OF POROUS FLUORITE ORE

Specimen contains skeletal barite crystals (Ba) and dark halos around bastnaesite (B) ; clear areas are voids; plane polarized light, x35; sec. 25, T. 1 S., R. 11 E.

Galena, chalcocite, and bornite generally occur in minor amounts; however, in some deposits (Deadwood, Red Cloud Copper, Rio Tinto, and Little Wonder) these sulfides are present in commercially significant quantities. Galena cubes (up to 10 mm) are randomly distributed throughout the ore, commonly as individual crystals rather than as aggregates. Chalcocite is the most abundant copper sulfide, and bornite occurs only in small amounts, both species as fine-grained masses. Bornite is randomly distributed, whereas chalcocite occurs as a replacement of galena and bornite. The copper sulfides are almost completely oxidized to azurite, malachite, and particularly chrysocolla, which occurs

as fine-grained aggregates and colloform masses. Galena has been altered to cryptocrystalline aggregates and tiny euhedra of pyromorphite and fine-grained cerussite. Tiny euhedra of anglesite were noted in a few specimens.

Pyrite is found in every deposit. Although the amount ranges from traces up to 7 or 8 percent, the pyrite content of the ore averages about 1.5 percent. The mineral occurs as tiny euhedra (0.1 to 5 mm), cubes and pyritohedrons, both with modifying forms.

At most deposits, barite is the second most abundant mineral, ranging from a trace to 35 percent. Most ore specimens contain about 7 to 8 percent barite. The mineral typically occurs as subhedral prismatic or tabular grains, up to 10 mm long, intimately intergrown with the fluorite mass or occurring in small cavities within the fluorite rock (fig. 10). The grains are most commonly white and opaque (or pink where iron stained), but transparent, colorless crystals are also present. Much of the barite has been dissolved to produce skeletal crystals that give the ore a honeycomb appearance (fig. 10).

Quartz is ubiquitous and ranges in concentration from a trace to about 20 percent; most ores contain about 5 percent. The mineral is irregularly distributed throughout an ore zone, as irregularly shaped grains and as euhedral, prismatic crystals. Well-developed terminated crystals commonly line the walls of fractures or cavities, thereby indicating the early paragenetic position of quartz.

Minor amounts of calcite are present in many deposits as extremely fine-grained masses filling open spaces in the mineralized rock. At places calcite is entirely absent; at a few it constitutes as much as 28 percent of the rock. The calcite content generally does not exceed 2 or 3 percent.

Bastnaesite has been reported from only 28 localities in the world, the Gallinas Mountains occurrence being the tenth reported. The paragenetic significance of bastnaesite has been discussed in a separate paper (Perhac and Heinrich, 1964). The mineral is probably an indicator of an alkalic environment but has no significance as to temperature or pressure.

Bastnaesite typically occurs as pale-yellow, transparent, thin, hexagonal plates, similar to mica. It also occurs in a prismatic habit with well-developed pyramidal faces. The platy grains range from 2 to 7 mm in diameter and generally less than 2 mm thick. A few prismatic crystals are as long as 10 mm. Although prismatic cleavage (1010) is poorly developed, the mineral possesses a distinct basal parting (0001) that is easily mistaken for true cleavage. The indices of refraction of the Gallinas Mountains bastnaesite are: $N_e = 1.819$, $N_o = 1.718$.

A bastnaesite specimen from the Red Cloud Fluorite mine was analyzed by the U. S. Bureau of Mines (Soule, 1946, p. 5):

R ₂ O ₃	74.39%	Ce	21.87%
F	7.46	Ce ₂ O ₃	25.61
CO ₂	19.94	(La, Di) ₂ O ₃	48.78
Ca	0.50		
Ba	0.55		
Fe	0.36		
H ₂ O at 600°C	<u>0.32</u>		
	103.52%		

This analysis corresponds to the formula RF(CO₃); R = (Ce, La, Di).

Supergene Minerals

Widespread oxidation of the ore has produced many supergene minerals. All pyrite is partly altered to limonite and hematite, which occurs as pseudomorphs after pyrite or as fine-grained disseminated aggregates that impart a brownish color to the ore. The most common oxidation products of the copper sulfides are chrysocolla, malachite, and azurite. Pyromorphite and cerussite are the most common super-gene lead species. Tiny anglesite crystals are sparse. Whereas pyromorphite occurs both as greenish-yellow cryptocrystalline aggregates and as tiny (0.1 mm long) prismatic crystals, cerussite occurs only as fine-grained aggregates.

TYPES OF FLUORITE-COPPER DEPOSITS

Breccia Zones

Most of the fluorite-copper deposits are in breccia zones associated with faults that have shattered the brittle Yeso sandstones. The zones range in width from a few inches (Summit prospect) to as much as 30 feet (Eagle Nest prospect), and in length from a few feet to many tens of feet. The breccia zone of the Eagle Nest prospect can be traced on the surface for 600 feet, but it may be as long as 1,500 feet. The width of brecciation along any given fault is highly irregular.

Other highly fractured zones occur at the intersections of major faults. The Red Cloud Fluorite deposit is in a nearly rectangular breccia zone that is bounded on three sides by large faults, one of which has a stratigraphic throw of about 400 feet. Brecciation covers an area of about 7,500 square feet to a depth of at least 140 feet and is confined entirely within the area bounded by the three faults. The All American deposit is similar, except that the breccia zone is at the intersection of two faults, one of which is the same fault along which the Red Cloud Fluorite zone occurs.

Mineralization occurs mainly as fillings in the many tiny fractures, producing fluorite and copper-mineral veinlets that are typically less than an inch wide and rarely are more than a few inches long. Mineralization also occurs commonly along bedding planes and joint surfaces

within the brecciated zone (Eagle Nest deposit). Replacement of host rock occurs only in cases of intense mineralization. Mineralization is generally confined to brecciated zones, except where ore-bearing fluids have migrated outward along bedding planes or joints. At the Rio Tinto mine, for example, bedding planes are weakly mineralized for a foot or less away from the brecciated rock. Because of deposition in open spaces at shallow depth, typical specimens from this class of deposit consist of a porous mass of fluorite with or without copper minerals.

Fissure Veins

True fissure veins, unassociated with wall-rock brecciation, have been noted only at the Little Wonder, Congress, and Pride No. 2 deposits. At the Pride No. 2, tiny fluorite veins, 1 to 3 inches wide, are in closely spaced fractures (probably joints) in porphyritic trachyte. At the Congress prospect, one of the two fluorite occurrences is in mineralized fault gouge, 3 to 4 feet wide, along a fault contact between Yeso sandstone and limestone. The best example of a fissure vein is at the Little Wonder mine, where a fluorite-copper vein is about 3 feet wide and at least 50 feet long (fig. 9).

The fissure veins associated with the breccia-zone deposits are generally narrow and discontinuous. Many deposits are actually a combination of breccia fillings and small fissure veins. This is particularly evident at the Eagle Nest and Eureka deposits. At the latter, distinct fissure veins, up to 70 feet long and 3 feet wide, occur in the mineralized Yeso breccia.

IRON DEPOSITS

GEOLOGY AND MINERALOGY

The Gallinas Mountains iron deposits are typical limestone replacements. The four major occurrences of iron are in Yeso limestone or gypsiferous limestone in contact with porphyritic trachyte. One very small prospect, however, is in limestone associated with the rhyolite in the western part of the Gallinas Mountains. The mineralized zones are irregular in shape and are entirely confined to limestone host rock. These facts and microscopic studies clearly indicate replacement, but fracture control is, nevertheless, evident. At the Iron Lamp deposit, for example, the mineralized limestone is bounded by two steeply dipping, northwestward-trending fractures about 3 feet apart. Although the deposit at the Red Cliff mine is a nearly flat-lying lens in limestone, very high concentrations of iron minerals occur along a prominent northeastward-trending set of fractures. At the American mine, many northwestward-trending fractures are apparent. The ore-forming fluid probably rose along the fracture systems and migrated laterally along bedding planes to replace the limestone. Where sandstone is also present, it is

noticeably unmineralized, except for small amounts of disseminated magnetite grains in the Yeso sandstones.

The mineralogy of the iron deposits is simple. Essentially magnetite, hematite, and limonite are the only minerals present, with local traces of pyrite. The calcite that is commonly mixed with the iron minerals is undoubtedly derived from the enclosing limestone, as is any gypsum that may be present. Quartz is present in small amounts. Locally tremolite and diopside, also derived from limestone, are dispersed throughout the mineralized rock.

The relative amounts of the three iron minerals differ considerably from place to place. At the American mine, for example, magnetite predominates, whereas, at the Iron Lamp deposit, magnetite is practically absent, and the ore is mainly a mixture of hematite and limonite. Magnetite typically occurs as irregularly shaped, fine-grained masses, with occasional small, megascopic octahedra. Polished-section study failed to reveal exsolution phenomena associated with magnetite. Hematite typically occurs as red, earthy masses. Some of it may be super-gene due to surficial oxidation of magnetite, although limonite would be the most likely product. Limonite is an abundant constituent of the ore; it generally occurs as yellow and dark-brown, earthy masses.

The economic potential of the Gallinas Mountains iron deposits is small. At both the Red Cliff and American mines, little ore remains, and the amount of iron at the Iron Lamp deposit is very small. Most of the iron ore reserves in the area are at the Little Marie deposit. The total reserves for the district probably do not exceed 75,000 tons, the tenor of which would be about 45 percent iron. These deposits, therefore, are not commercially significant at present.

TYPES OF IRON DEPOSITS

Arbitrarily, the iron deposits are classed as either fracture-controlled replacements or as irregular replacement bodies, depending on the extent to which replacement is controlled by the position of prominent fractures.

The only example of a fracture-controlled replacement is the hematite-limonite deposit at the Iron Lamp claim. The deposit is in a gently dipping, small xenolith of Yeso limestone in porphyritic trachyte. The iron minerals have replaced the limestone between two nearly vertical fractures about 3 to 4 feet apart. Within the fracture zone the limestone is nearly uniformly replaced.

In contrast to the Iron Lamp deposit are those at which the carbonate bed or beds are irregularly replaced. Although particularly high concentrations of iron minerals occur along joints and other fractures, the actual shape of the ore body is not controlled by the position of the fractures. The Red Cliff claim comprises two manto-type ore bodies. Nearly horizontal Yeso gypsiferous limestone and sandstone overlie a trachyte

sill. A gypsiferous limestone bed, 5 to 8 feet thick and 10 to 30 feet above the trachyte, was selectively replaced by magnetite and hematite, producing two nearly horizontal lens-shaped ore bodies, one about 20 by 150 by 6 feet thick, the other about 60 by 100 by 8 feet thick.

Similarly, the American and Little Marie deposits are irregular re-placements of limestone xenoliths within the trachyte. The Little Marie deposit is in a 350-foot-long xenolith of dipping limestone and sandstone in which two limestone beds (each about 10-15 feet thick) have been almost completely replaced by the iron minerals. The xenolith at the American claim, however, is almost entirely silicated limestone (tremolite-diopside), plus minor sandstone. The lime-silicate minerals have been variably replaced to produce an irregularly shaped ore body within the horseshoe-shaped xenolith.

ORIGIN OF THE ORE DEPOSITS

PARAGENESIS

Fluorite-Copper Deposits

Most of the fluorite-copper deposits show evidence of at least two stages of hypogene mineralization that are separated by a period of fracturing (fig. 11). The first stage includes deposition of quartz, barite, sulfides (pyrite, bornite, galena), fluorite, bastnaesite, and perhaps minor calcite, probably in that order with some overlap. Additional barite, fluorite, and calcite were deposited during the second stage.

The early precipitation of quartz is indicated by the abundance of euhedral crystals and by the presence of inward-projecting crystals that line cavity walls with a typical cockscomb texture. Later minerals were then deposited in the central part of the fracture. Also, overgrowths of tiny fluorite clusters on quartz grains are common.

Most of the barite was formed early, but some represents a second generation that was precipitated during the post-fracturing stage. Crystals of the older barite are commonly etched, with fluorite crystals precipitated in the solution cavities. The second-generation barite formed in cavities in the older fluorite.

Deposition of pyrite, galena, and bornite followed that of barite and, in turn, was followed by the deposition of fluorite and bastnaesite, respectively. Bastnaesite crystals occur along cleavage planes in barite and fluorite and on fluorite crystal faces. A minor amount of calcite may have crystallized with the bastnaesite to complete the first stage of mineralization.

Following the initial stage of mineralization, fault movement fractured the deposits anew. Many of the early-formed minerals are either fractured or bent. Bastnaesite particularly shows this fracturing, with second-generation fluorite filling the fractures. During the second stage

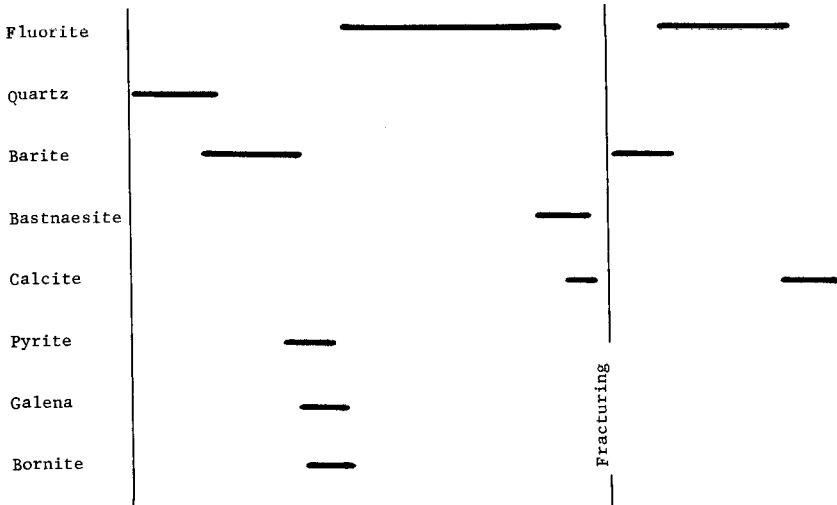

Figure 11

PARAGENESIS (HYPOGENE STAGES) OF FLUORITE-COPPER DEPOSITS IN THE GALLINAS MOUNTAINS

of mineralization, mainly barite, fluorite, and calcite were precipitated. At only one deposit were two generations of quartz noted. At some prospects, however, some late silica was deposited as chalcedony in tiny cavities. The occurrence of chalcedony is uncommon.

Supergene alteration is the third stage in the formation of the deposits. Pyrite was oxidized and hydrated to hematite and limonite. Bornite was attacked, and the dissolved copper later precipitated as supergene chalcocite on galena and bornite. The copper sulfides were subsequently oxidized to chrysocolla, malachite, and minor azurite. These secondary copper species occur as coatings on the sulfides and as void fillings. Galena was altered to cerussite, pyromorphite, and locally to anglesite.

Iron Deposits

The first step in the formation of the iron deposits was introduction of silica, which is manifested by (1) minor silicification of Yeso sand-stones and (2) crystallization of minor amounts of quartz in Yeso carbonate beds. At the skarn localities, some silica went into the formation of the lime-silicate minerals. Following the introduction of silica, iron was added. At the skarn deposits, some iron was first used for the formation of tremolite-diopside, with the dolomite in the host rock providing magnesium. The excess iron was precipitated as magnetite and hematite.

How much hematite may have resulted from oxidation of magnetite is unknown. Associated with the iron ore are traces of pyrite, this mineral having crystallized after the iron oxides.

TEMPERATURE-DEPTH ENVIRONMENT

The mineral deposits in the Gallinas Mountains probably formed at temperatures of less than 300°C. The fluorite-copper deposits contain no critical minerals; however, a fluid-inclusion study of bastnaesite indicates a crystallization temperature of 175° to 185°C (Perhac and Heinrich, 1964, p. 234). Based on texture, the bastnaesite is a late mineral, hence the initial temperature for the deposits may have been higher. As these are shallow deposits, the pressure correction is probably less than 20° to 25°C, and it is reasonable to conclude that the fluorite-copper deposits formed at temperatures near 200°C.

The temperature at which the iron deposits formed is not easily defined. An upper limit is the temperature of the contact metamorphism because, paragenetically, the ore minerals are later than the lime silicates, which could have formed at less than 300°C. The iron lodes are closer to the igneous rock than are the fluorite-copper deposits, hence a higher temperature might be presumed for the iron minerals, and they may have been deposited between about 200° and 300°C. No more definite limits can be given.

The presence of gypsum with magnetite at the Red Cliff mine might suggest a maximum temperature for the iron mineralization. The mineralization would have occurred at a temperature lower than the dehydration temperature of gypsum, which will invert to anhydrite at 58°C at 1 atmosphere and water activity of 1 (Hardie, 1967). On burial, however, the transition temperature depends on depth, pressure differential of solid and liquid phases, reaction rate, water activity, and permeability of the system. Also, it would be necessary to assume that the gypsum is primary and was not dehydrated during mineralization and subsequently hydrated back to gypsum. Because of the uncertainty of these factors, the use of the gypsum as a geothermometer is questionable.

The depth at which the mineral deposits formed is unknown because of the removal of all post-Glorieta sedimentary rocks from the Gallinas Mountains, but regional considerations suggest that the original sedimentary cover may not have exceeded 3,700 feet.

CLASSIFICATION AND ORIGIN

The metalliferous ores, particularly the magnetite deposits, in the central New Mexico intrusive belt of Lincoln County, are commonly associated with small, subsilicic intrusives. The iron mineralization generally is related spatially and temporally to contact metamorphism. This is the case of the Gallinas Mountains iron deposits, which are low-

temperature replacement lodes at or near the trachyte contact and arc apparently genetically related to the trachyte.

The fluorite-copper deposits have also been classed as contact metamorphic (Glass and Smalley, 1945, p. 613), but their texture, structure, and mineralogy indicate otherwise. Their proximity to the igneous contact strongly suggests a magmatic affinity, but they were almost certainly derived from hydrothermal fluids released from the trachyte magma.

Despite the apparent common origin of the two types of mineralization, a more precise relation cannot be suggested because of the absence of zonation. The iron mineralization appears to have preceded the fluorite-copper stage, suggesting that the sequence of events was (1) emplacement of magma, (2) deuteric alteration, (3) hydrothermal alteration, (4) localized contact metamorphism of limestone, (5) iron mineralization, and (6) fluorite-copper mineralization.

References

- Anderson, E. C., 1957, The metal resources of New Mexico and their economic features through 1954: N. Mex. State Bur. Mines Mineral Resources, Bull. 39, 183 p.
- Budding, A. J., 1964, Geologic outline of the Jicarilla Mountains, Lincoln County, New Mexico, *in* Guidebook of the Ruidoso country: N. Mex. Geol. Soc., Guidebook, 15th Field Conf., p. 82-86.
- Darton, N. H., 1922, Geologic structure of parts of New Mexico: U. S. Geol. Survey, Bull. 726-E, p. 173-275.
- , 1928a [1929], "Red beds" and associated formations in New Mexico, with an outline of the geology of the state: U. S. Geol. Survey, Bull. 794, 356 p.
- , 1928b, Geological map of New Mexico: U. S. Geol. Survey.
- Elston, W. E., and Snider, H. I., 1964, Differentiation and alkali metasomatism in dike swarm complex and related igneous rocks near Capitan, Lincoln County, New Mexico, *in* Guidebook of the Ruidoso country: N. Mex. Geol. Soc., Guidebook, 15th Field Conf., p. 140-147.
- Glass, J. J., and Smalley, R. G., 1945, Bastnaesite: Amer. Mineralogist, v. 30, p. 601-615.
- Griswold, G. B., 1959, Mineral deposits of Lincoln County, New Mexico: N. Mex. State Bur. Mines Mineral Resources, Bull. 67, 117 p.
- Hardie, L. A., 1967, The gypsum-anhydrite equilibrium at one atmosphere pressure: Amer. Mineralogist, v. 52, p. 171-200.
- Hills, J. M., 1942, Rhythm of Permian seas—a paleogeographic study: Amer. Assoc. Petroleum Geologists, Bull., v. 26, p. 217-255.
- Johnson, W. D., Jr., 1928, Fluorspar in New Mexico: N. Mex. State Bur. Mines Mineral Resources, Bull. 4, 128 p.
- Jones, F. A., 1904, New Mexico mines and minerals: Santa Fe, New Mexico Printing Co., 349 p.
- Kelley, V. C., 1946, Geologic and topographic map of the eastern Gallinas Mountains, Lincoln County, New Mexico: U. S. Geol. Survey, Strategic Minerals Inv. Prelim. Map 3-211.
- , 1949, Geology and economics of New Mexico iron-ore deposits: N. Mex., Univ., Publ., Geology Ser., n. 2, 246 p.
- , 1955, Regional tectonics of south-central New Mexico, *in* Guidebook of south-central New Mexico: N. Mex. Geol. Soc., Guidebook, 6th Field Conf., p. 96-104.
- Kelley, V. C., and Thompson, T. B., 1964, Tectonics and general geology of the Ruidoso-Carrizozo region, central New Mexico, *in* Guidebook of the Ruidoso country: N. Mex. Geol. Soc., Guidebook, 15th Field Conf., p. 110-121.
- Kottlowski, F. E., 1963, Paleozoic and Mesozoic strata of southwestern New Mexico: N. Mex. State Bur. Mines Mineral Resources, Bull. 79, 100 p.
- Kottlowski, F. E., Weber, R. H., and Willard, M. E., 1969, Tertiary intrusive-volcanic-mineralization episodes in the New Mexico region (abs.): Geol. Soc. America, Programs Abs. 1969, pt. 7, 1969 Ann. Mtg., p. 278-280.
- Larsen, E. S., 1940, Petrographic province of central Montana: Geol. Soc. America, Bull., v. 51, p. 887-948.
- Lasky, S. G., and Wootton, T. P., 1933, The metal resources of New Mexico and their economic features: N. Mex. State Bur. Mines Mineral Resources, Bull. 7, 178 p.
- Lindgren, Waldemar, Graton, L. C., and Gordon, C. H., 1910, The ore deposits of New Mexico: U. S. Geol. Survey, Prof. Paper 68, 361 p.

- Lonsdale, J. T., 1940, Igneous rocks of the Terlingua-Solitario region, Texas: Geol. Soc. America, Bull., v. 51, p. 1539-1626.
- Lovering, T. S., and Goddard, E. N., 1950 [1951], Geology and ore deposits of the Front Range, Colorado: U. S. Geol. Survey, Prof. Paper 223, 319 p.
- Needham, C. E., 1942, Permian system of central New Mexico, *in* Bates, R. L., The oil and gas resources of New Mexico: N. Mex. State Bur. Mines Mineral Resources, Bull. 18, p. 34-37.
- Needham, C. E., and Bates, R. L., 1943, Permian type sections in central New Mexico: Geol. Soc. America, Bull., v. 26, p. 1653-1668.
- Perhac, R. M., and Heinrich, E. W., 1964, Fluorite-bastnaesite deposits of the Gallinas Mountains, New Mexico, and bastnaesite paragenesis: Econ. Geology, v. 59, p. 226-239.
- Rawson, D. E., 1957, The geology of the Tecolote Hills area, Lincoln County, New Mexico: N. Mex., Univ., unpublished M. S. thesis.
- Rothrock, H. E., 1946, Geology and description of the deposits, *pt. 1 of* Rothrock, H. E., Johnson, C. H., and Hahn, A. D., Fluorspar resources of New Mexico: N. Mex. State Bur. Mines Mineral Resources, Bull. 21, p. 11-193.
- Soule, J. H., 1946, Exploration of Gallinas fluorspar deposits, Lincoln County, New Mexico: U. S. Bur. Mines, Rept. Inv. 3854.
- Talmage, S. B., and Wootton, T. P., 1937, The non-metallic mineral resources of New Mexico and their economic features (exclusive of fuels): N. Mex. State Bur. Mines Mineral Resources, Bull. 12, 159 p.
- Thompson, M. L., 1942, Pennsylvanian System in New Mexico: N. Mex. State Bur. Mines Mineral Resources, Bull. 17, 92 p.
- Turner, F. J., 1958, Mineral assemblages of individual metamorphic facies, *ch. VII in* Fyfe, W. S., Turner, F. J., and Verhoogen, J., Metamorphic reactions and metamorphic facies: Geol. Soc. America, Mem. 73, p. 199-239.
- Walker, G. W., and Osterwald, F. W., 1956, Uraniferous magnetite-hematite deposit at the Prince mine, Lincoln County, New Mexico: Econ. Geology, v. 51, p. 213-222.
- Weber, R. H., 1964, Geology of the Carrizozo quadrangle, New Mexico, *in* Guidebook of the Ruidoso country: N. Mex. Geol. Soc., Guidebook, 15th Field Conf., p. 100-109.
- Winkler, H. G. F., 1967, Petrogenesis of metamorphic rocks: New York, Springer-Verlag, 237 p.

Index

Numbers in **boldface** indicate main sections

- Abo Formation, 7, **8-9**
age of deformation, **32**
age of intrusives, **30**
albitization, 16, 18, 24
All American mine, 35, 38, 41
alluvial deposits, 4
alteration, 24, 36
American mine, 26, 35, 42, 43, 44
Anderson, E. C., cited, 5, 35
andesite **21-23**, 30
 petrogenesis, **26**
arkose, 8
- Basin and Range disturbance, 34
bastnaesite, 35, 40
Bates, R. L., cited, 11
Bernal Formation, 28
Bone Springs Limestone, 33
Bottleneck prospect, 38
breccia pipes, 23
breccia zones, **41-42**
Budding, A. J., cited, 28
- Camelon Hill, 8
Capitan, 29
Capitan aplite, 28
Carrizo Mountain, 28
Carrizozo, 3
Cedarvale (Rattlesnake Hills), 8
Cerrillos Hills, 30
Cerro Blanco (Sierra Blanca Peak), 28, 39
Chavez area, 29
Cibola National Forest, 3
Congress prospect, 38, 42
Conqueror No. 4 prospect, 38
copper, 35
Corona (Camelon Hill), 3, 8
Cougar Mountain, 13
Cub area, 29
- Dakota Sandstone, 30
Darton, N. H., cited, 5
Deadwood mine, 38, 39
Delaware basin, 33
domal uplift, **31**
Duran, 8
- Eagle Nest prospect, 38, 41, 42
Elston, W. E., cited, 29
eluvium, 4
- Eschman, D. F., 5
Eureka prospect, 38
- faults, **31-32**
fissure veins, **42**
fluid inclusion, 46
fluorite, 35
fluorite-copper deposits, **36-42**
 paragenesis, **44-45**
foliation, 31
- geologic history, **33-34**
Geological Society of America, 6
Glass, J. J., cited, 47
Glorieta Sandstone, 7, **11-13**
Goddard, E. N., 5
 cited, 34
gold, 35
Gordon, C. H., cited, 5
granite, 7-8, 33
Graton, L. C., cited, 5
Griswold, G. B., cited, 5, 35
- Hardie, L. A., cited, 46
Heinrich, E. W., 5
 cited, 40, 46
Hills, J. M., cited, 33
Hilltop prospect, 38
Holocene deposits, 4
Hoosier Girl North prospect, 38
Hoosier Girl South prospect, 38
Hueco Limestone, 33
Humble Oil & Refining Co., 6
hypogene minerals, 37-41
- iron, 35
iron deposits, **42-44**
 paragenesis, **45-46**
Iron Lamp prospect, 42, 43
- Jicarilla Mountains, 28
Johnson, W. D., cited, 5
Jones, F. A., cited, 35
- Kelley, V. C., cited, 5, 28, 33, 35
Kellum, L. B., 5
Kopp, O. C., 5
Kottlowski, F. E., cited, 28, 30
- laccolith, 15, 20, 31
Laramide disturbance, 34

- Larsen, E. S., cited, 34
 Lasky, S. G., cited, 5
 Last Chance mine, 38
 latite, **13-14**
 age, 30
 petrogenesis, **24-25**
 lead, 35
 Lindgren, Waldemar, cited, 5
 Little Marie prospect, 44
 Little Wonder mine, 38, 39, 42
 Lone Mountain, 28, 30
 Lonsdale, J. T., cited, 34
 Lovering, T. S., cited, 34
- M and E No. 13 prospect, 36, 38
 metamorphism, **26-27**
 Michigan, University of, 6
 microsyenite, 14-15, **18-20**
 petrogenesis, **25**
 mineral deposits, **35-47**
 mineralogy of fluorite-copper deposits,
37-41
 mineralogy of iron deposits, 42
 Motts, W. S., 5
- Needham, C. E., cited, 11, 12
- ore deposits, origin of, **44-47**
 orthoquartzite, 11
 Osterwald, F. W., cited, 28
 oxidation, 41
- paragenesis of fluorite-copper deposits,
44-45
 paragenesis of igneous rocks, **23-24**
 paragenesis of iron deposits, **45-46**
 Patos Mountain, 28
 Pedernal Hills, 8, 9
 Pedernal landmass, 33
 Perhac, R. M., cited, 40, 46
 Permian, **8-13**
 petrogenesis, **24-26**
 petrology, **7-30**
 physiography, 3
 potassium-argon date, 30
 Precambrian, **7-8**, 33
 Pride No. 2 prospect, 36, 38, 42
- Quaternary deposits, 4-5
- radioactivity, 39
 radiometric date, 30
 rainfall, 3
 Rattlesnake Hills, 8
 Rawson, D. E., cited, 28
- Red Cliff mine, 35, 42, 43
 Red Cloud Canyon, 7, 31
 Red Cloud Copper mine, 35, 38, 39
 Red Cloud district, 5, 35
 Red Cloud Fluorite mine, 35, 38, 40, 41
 replacement bodies, 43
 reserves, 43
 rhyolite, **20-21**, 31
 age, 30
 petrogenesis, **25-26**
 Rio Tinto mine, 35, 38, 39, 42
 Rothrock, H. E., cited, 5
- Sacramento Mountains, 33
 San Andres Limestone, 13, 28, 33
 Sierra Blanca, 30
 Sierra Blanca Peak (Cerro Blanco), 28,
 39
 silver, 35
 skarn, 27
 Sky High prospect, 38
 Smalley, R. G., cited, 47
 Snider, H. I., cited, 29
 Socorro County, 3
 Soule, J. H., cited, 5, 40
 Southern Pacific Railway, 3
 stock, 14
 stratigraphy, Permian, 7
 structural geology, **31-32**
 Summit prospect, 38, 41
 supergene alteration, 41, 45
- Talmage, S. B., cited, 5
 Tecolote Hills, 28, 30
 temperature, 27, 46
 Tertiary igneous rocks, **13-24**
 Thompson, M. L., cited, 8
 Thompson, T. B., cited, 28
 trachyte, 14, **15-18**, 31
 age, 30
 petrogenesis, **25**
 trachyte breccia, **23**
 petrogenesis, **26**
 Turneure, F. S., 5
 Turner, F. J., cited, 27
- Walker, G. W., cited, 28
 Weber, R. H., cited, 28, 29, 30
 Willard, 11
 Willard, M. E., cited, 30
 Willow area, 29
 Winkler, H. G. F., cited, 27
 Wootton, T. P., cited, 5
- Yeso Formation, 7, **9-11**, 13

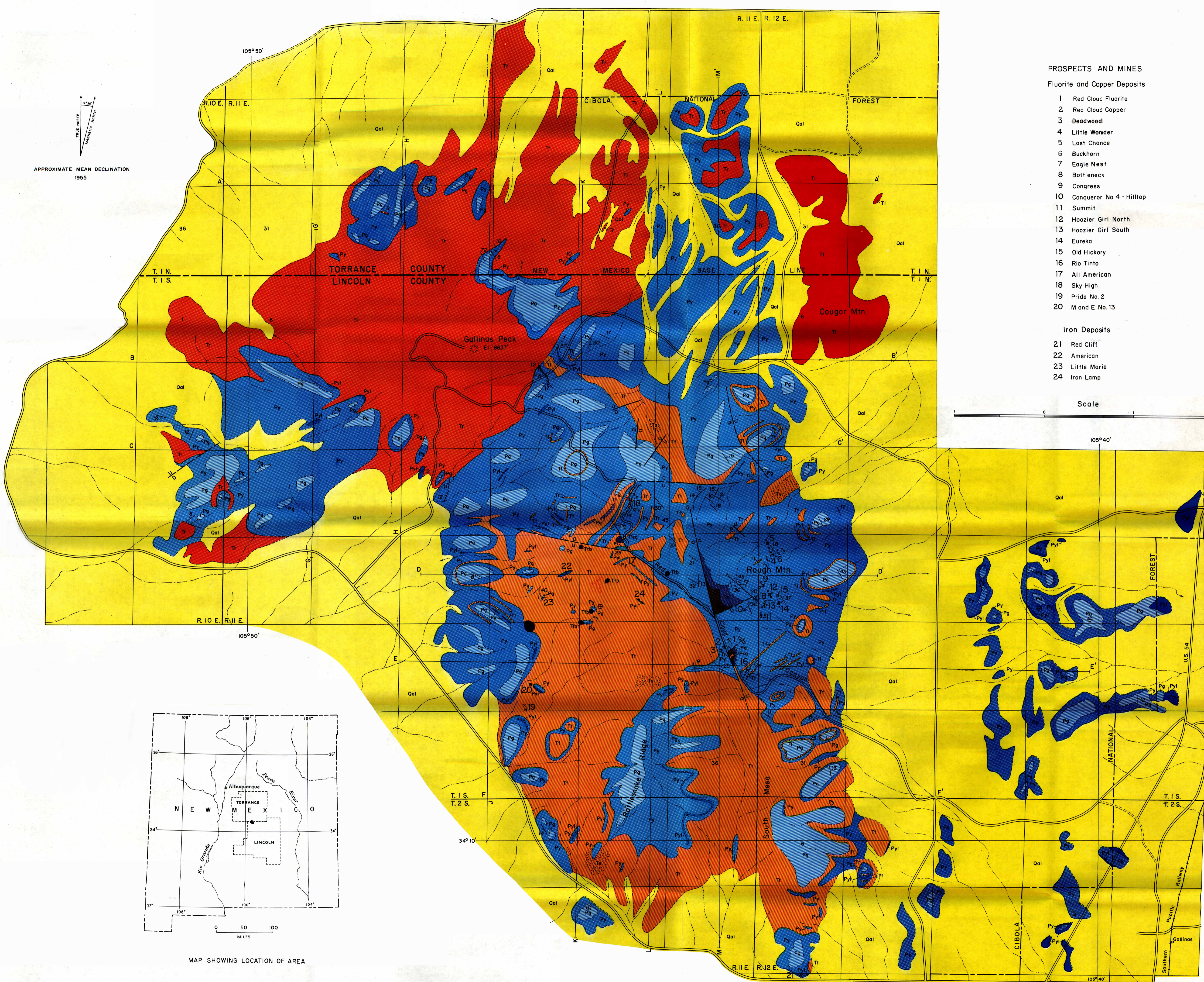

- PROSPECTS AND MINES**
- Fluorite and Copper Deposits**
- 1 Red Clouc Fluorite
 - 2 Red Clouc Copper
 - 3 Deadwood
 - 4 Little Wonder
 - 5 Last Chance
 - 6 Buckhorn
 - 7 Eagle Nest
 - 8 Bottleneck
 - 9 Congress
 - 10 Conqueror No. 4 - Hilltop
 - 11 Summit
 - 12 Hoozier Girl North
 - 13 Hoozier Girl South
 - 14 Eureka
 - 15 Old Hickory
 - 16 Rio Tinto
 - 17 All American
 - 18 Sky High
 - 19 Pride No. 2
 - 20 M and E No. 13
- Iron Deposits**
- 21 Red Cliff
 - 22 American
 - 23 Little Marie
 - 24 Iron Lamp

EXPLANATION

- Alluvium
- Trachyte breccia
(Breccia bodies containing fragments of sandstone, limestone, shale, andesite, trachyte and granite)
- Trachyte
(Tt, porphyritic trachyte; Ts, microsyenite phase)
- Porphyritic rhyolite
- Porphyritic latite
- Glorieta Formation
(White, quartzose sandstone)
- Yeso Formation
(Py, fine-grained, pink to buff, feldspathic sandstone, siltstone and minor shale; Pyl, limestone and dolomite)
- Abo Formation
(Red, arkosic conglomerate, sandstone and siltstone)
- Granite
(Light gray, massive, equigranular granite; locally aplitic)

- Contact
(Approximately located)
- Strike and dip of beds
- Horizontal beds
- Fault
(Dashed where approximately located; U, upthrown side; D, downthrown side)
- Shaft
- Adit
- Prospect pit
- Open pit mine
- Vein
(Shown at prospects number 4-5, 7, 8, 9, 10, and 19)

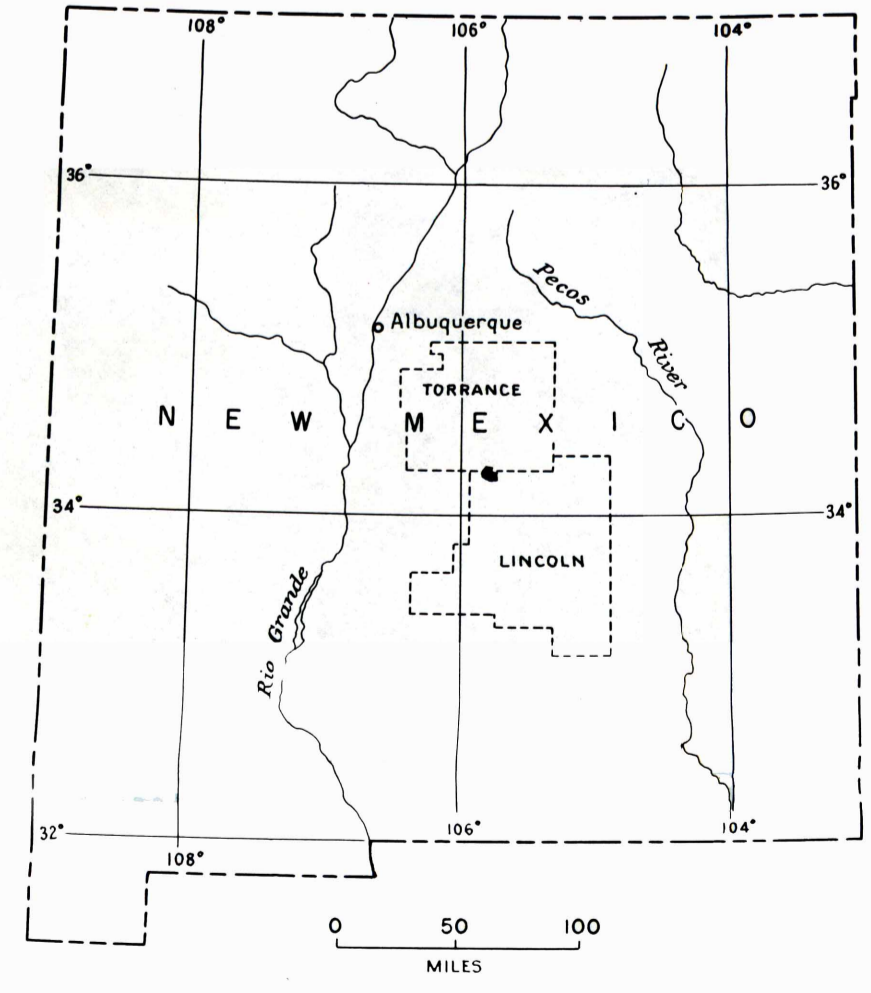

MAP SHOWING LOCATION OF AREA

¹A Division of New Mexico Institute of Mining and Technology

Base from U. S. Forest Service

Geology by Ralph M. Perhac, 1960

GEOLOGIC MAP OF THE GALLINAS MOUNTAINS LINCOLN AND TORRANCE COUNTIES, NEW MEXICO

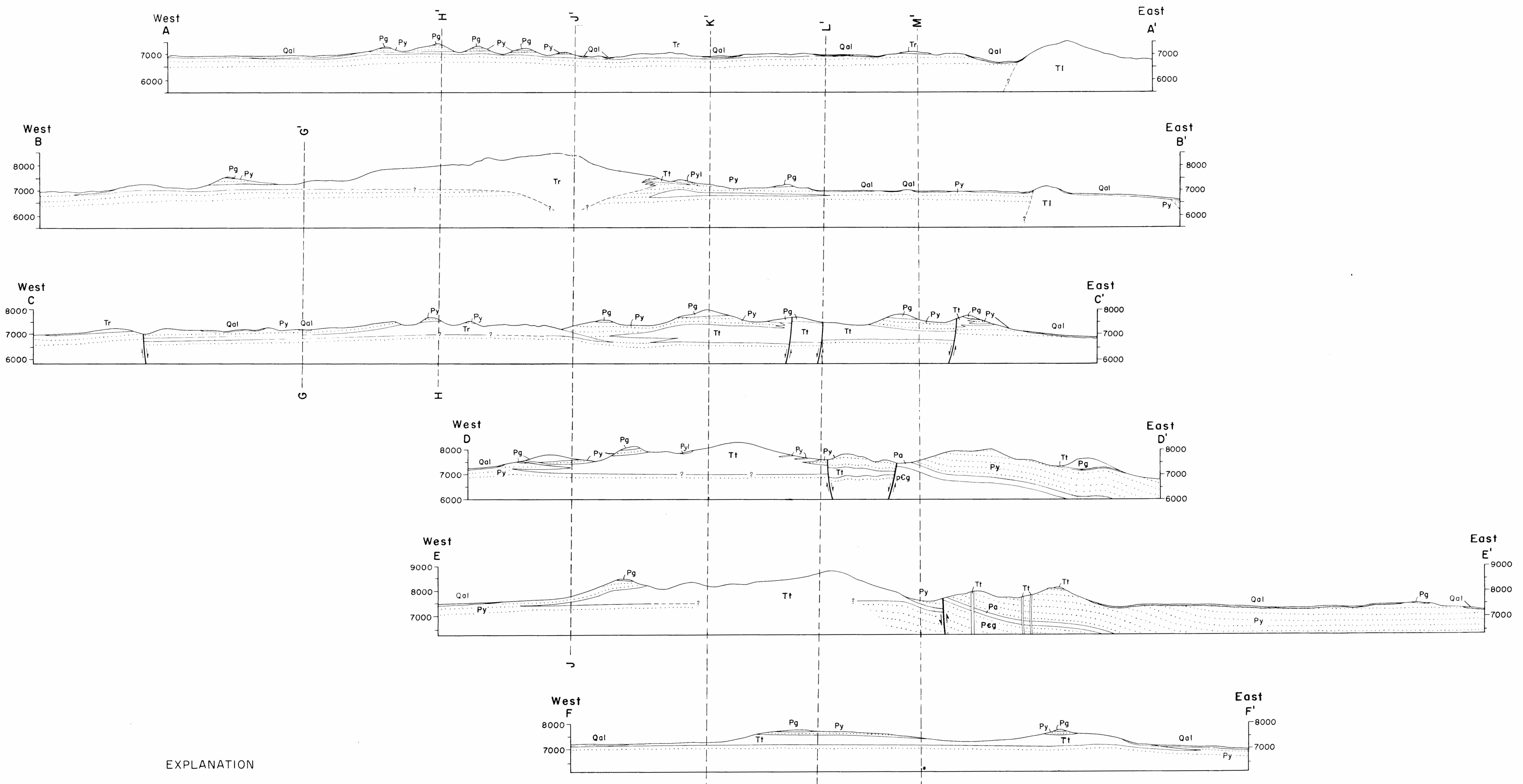

EXPLANATION

- Qal Alluvium
- Tr Porphyritic rhyolite
- Tt Trachyte
- Pg Glorieta Formation
- Py Yaso Formation, Pyl, limestone member
- Pa Abo Formation
- Pcg Granite

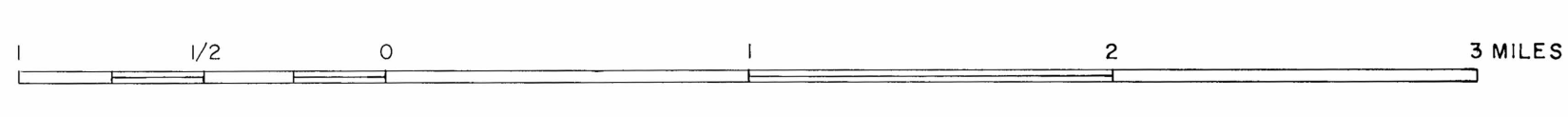
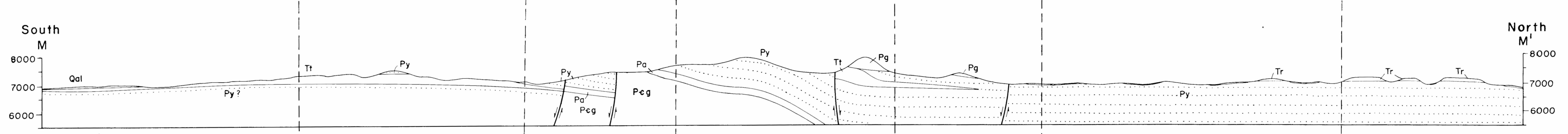
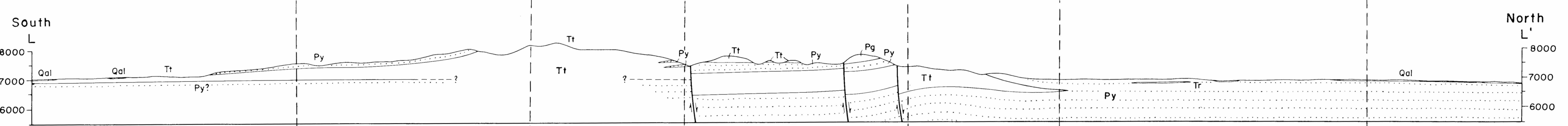
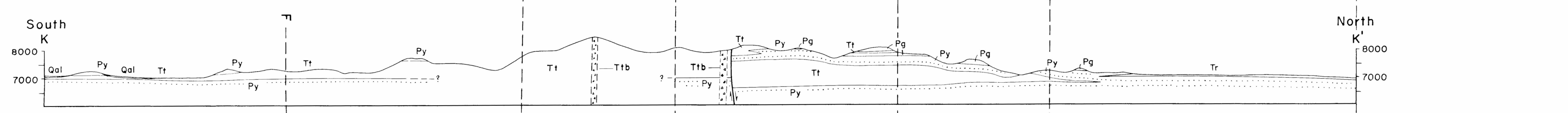
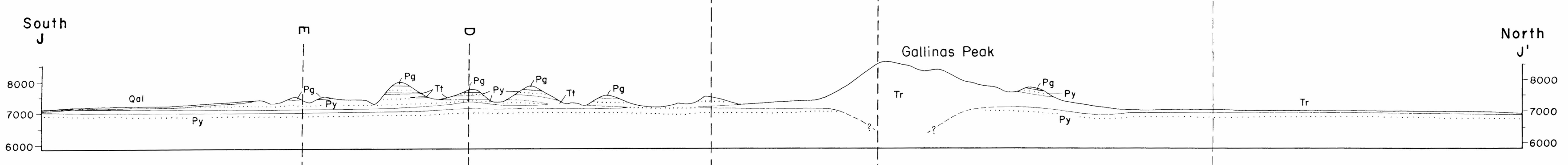
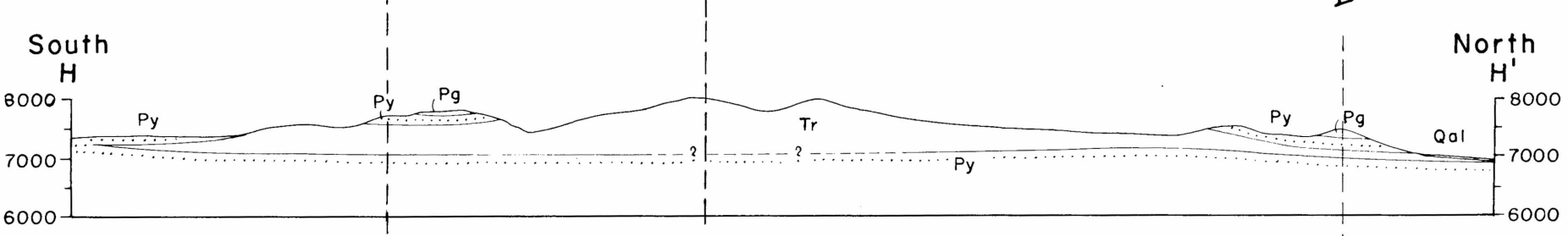
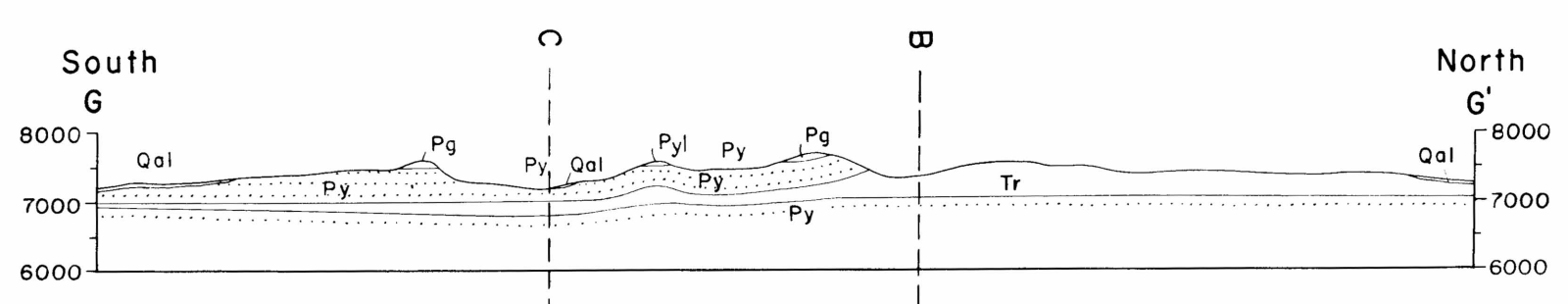

A Division of New Mexico Institute of Mining and Technology

Geology by Ralph M. Perhac, 19

GEOLOGIC STRUCTURE SECTIONS OF THE GALLINAS MOUNTAINS, LINCOLN AND TORRANCE COUNTIES, NEW MEXICO

See Geologic Map (Plate I) for location of section lines